

cookworks

Hand Mixer

Model No. HM9018B-GS



Care & Instruction Manual

For household and indoor use only

Please read these instructions before use and retain for future reference



ELECTRICAL SAFETY

- You should only plug the appliance into a 220V-240V AC, 50Hz supply. Connecting it to other power sources may damage the appliance and will invalidate the guarantee.
- Switch off and unplug if unattended and before assembling, disassembling or cleaning.
- This appliance shall not be used by children. Keep the appliance and its cord out of reach of children.
- This appliance can be used by persons with reduced physical, sensory or mental capabilities or lack of experience and knowledge if they have been given supervision or instruction concerning use of the appliance in a safe way and understand the hazards involved.
- Children shall not play with the appliance.
- Keep motor housing, cable and plug dry and away from areas where it is likely to get splashed. Never immerse in water.
- Do not cover or block the ventilation holes.
- Do not pull on the cable to disconnect from mains supply.
- Do not operate the appliance if damaged or after it malfunctions. In the event the supply cord is damaged, in order to avoid a hazard it must only be replaced by a qualified service engineer, with a suitably approved part.
- This appliance must be positioned so that the plug is accessible and the plug socket is within easy reach of the power cord.

WARNING!

- This appliance is intended exclusively for use in domestic households. It is not suitable for commercial use.
- Only use with the parts provided.
- Never place hands or utensils inside the mixing bowl or near the mixing heads whilst the mixer is in use. Only use a scraper when the mixer is not in operation.
- Do not cover the mixer and allow the motor housing to cool fully before storing.
- Do not leave unattended during use.
- This appliance can cause personal injury if misused.

PARTS

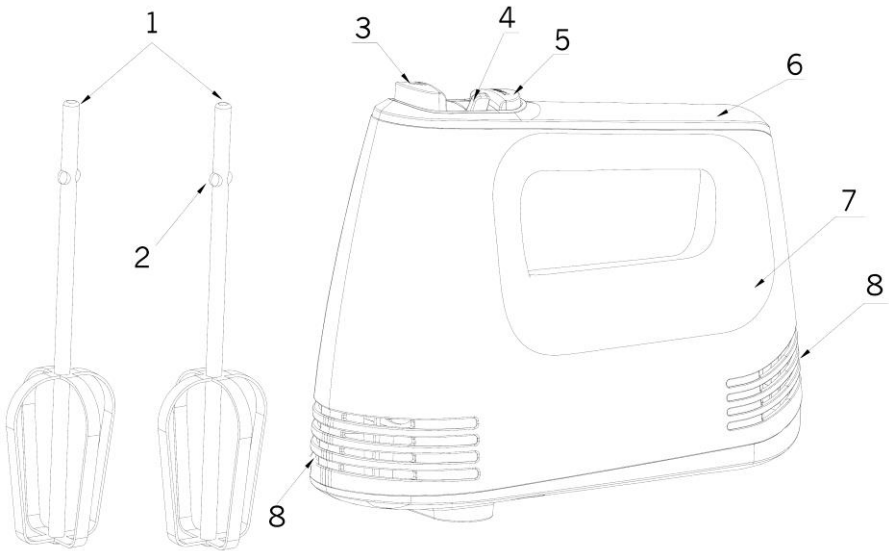

1. Beaters

2. Notch

3. Eject button

4. Speed slider

5. Turbo button

6. Handle

7. Motor housing

8. Ventilation holes

FITTING THE BEATERS

1. To fit the beaters, insert the beaters into the sockets on the underside of the motor housing, align the notch on the beater post with the grooves of the socket and then push firmly.

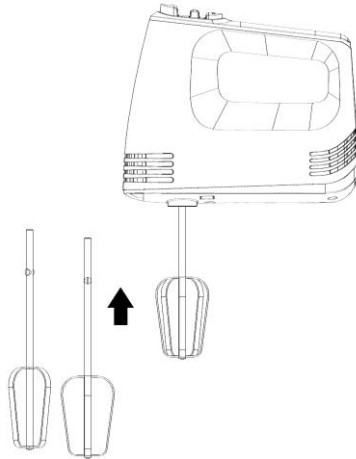

2. To eject the beaters, hold the mixing heads with one hand and press the eject button firmly with the other. Note the eject button will only operate if the speed slider is in the off (0) position.

TO USE

1. Clean thoroughly before first use.
2. Place the ingredients to be mixed into a suitable container and place the container on a stable surface.
3. Fully unwind the hand mixer cable and check that the speed control slider is in the off (0) position.
4. Fit the beaters into the motor housing and plug in.
5. Place the mixing heads into the ingredients to be blended. Do not immerse beyond the top of the mixing heads.
6. Switch on and using the speed slider, select the mixer speed of choice. Speed 1 is the slowest setting and speed 5 the fastest.
7. If the TURBO (pulse) button is held down whilst the mixer is in operation the highest speed setting will be immediately selected. When the button is released the mixer will slow to the speed shown on the speed control slider.
8. To switch off, move the speed control slider to the off (0) position and allow the mixing heads to come to a complete stop before checking the consistency of the mix. If satisfactory, remove the mixer.
9. Mix for a **maximum** of 5 minutes. If further mixing is required, wait at least 20 minutes before restarting the mixer.
10. To stop or interrupt the mixing process, move the speed slider to the off (0) position or turn off at the mains.

Notes:

- Do not run the mixer dry (without the mixing heads in the ingredients).
- Use refrigerated ingredients (e.g. butter and margarine) at room temperature.

Notes (continued)

- To minimise splashing and when adding powders, use a mixing bowl with deep sides, place the mixing heads as far as possible into the ingredients and start the mixer on the slowest speed setting working up to the higher setting.
- Do not over beat, start mixing at the slowest (1) speed and increase to the recommended speed stated in the recipe.
- When folding dry ingredients, use slowest speed setting.

CLEANING

1. Switch off and unplug.
2. Remove the beaters and wash these in hot water with a little washing up liquid. Rinse and wipe dry. The beaters are suitable for dishwashers.
3. Wipe the outside of the motor housing and cable with a damp cloth and then wipe dry. Do not use detergent or abrasives as these may scratch the surface.
4. Never immerse the motor housing, cable or plug in water and not suitable for dishwashers.

TECHNICAL SPECIFICATION

Cookworks Hand Mixer		
Model		HM9108B-GS
Rated Voltage & Frequency		220-240V AC 50/60Hz
Rated Power Input		200W
Maximum work time	Speeds 1 -5	5 minutes
	Turbo	5 minutes
Class rating		2 (double insulated)
BS 1362 fuse		5A
Product dimensions (external)		15.3 x 7.9 x 18.1 mm
Product weight (net)		0.8 kg approx.



RECYCLING ELECTRICAL PRODUCTS

You should now recycle your waste electrical goods and in doing so help the environment.

This symbol means an electrical product should not be disposed of with normal household waste. Please ensure it is taken to a suitable facility for disposal when finished with.



Visit www.recycle-more.co.uk, click on “bank locator” and enter your postcode to find your nearest recycling site.



PRODUCT GUARANTEE

This product is guaranteed against manufacturing defects for a period of



Year

This product is guaranteed for twelve months from the date of original purchase.

Any defect that arises due to faulty materials or workmanship will either be replaced, refunded or repaired free of charge where possible during this period by the dealer from whom you purchased the unit.

The guarantee is subject to the following provisions:

- The guarantee does not cover accidental damage, misuse, cabinet parts, knobs or consumable items.
- The product must be correctly installed and operated in accordance with the instructions contained in this manual. A replacement copy of this instruction manual can be obtained from www.argos-support.co.uk
- It must be used solely for domestic purpose.
- The guarantee will be rendered invalid if the product is re-sold or has been damaged by inexpert repair.
- Specifications are subject to change without notice.
- The manufacturer disclaims any liability for the incidental or consequential damages.
- The guarantee is in addition to, and does not diminish your statutory or legal rights.

Guarantor: Argos Ltd
489 - 499 Avebury Boulevard
Central Milton Keynes
MK9 2NW
www.argos-support.co.uk