

Shark

DuoClean® Corded Stick Vacuum with Anti-Hair Wrap Technology

HZ400UK Series

INSTRUCTIONS



sharkclean.eu



+44 (0)800 862 0453

THANK YOU

for purchasing the Shark Duoclean® Corded Stick Vacuum with Anti-Hair Wrap



TIP: You can find the model and serial numbers on the QR code label located on the back of your unit.

TIP: You can locate the date code on one of the prongs of the power cord plug.

REGISTER YOUR PURCHASE

- registermyshark.com
- +44 (0)800 862 0453
- Scan QR code using mobile device

Benefits of registering your product and creating an account:

- Get easier, faster product support and access to warranty information
- Access troubleshooting and product care instructions
- Be among the first to know about exclusive product promotions

RECORD THIS INFORMATION

Model Number: _____

Serial Number _____

Date Code: _____

Date of Purchase (Keep receipt): _____

Store of Purchase: _____

TECHNICAL SPECIFICATIONS

Voltage: 220-240V~, 50-60Hz

Watts: 500W

PLEASE READ CAREFULLY AND KEEP FOR FUTURE REFERENCE.

This instruction manual is designed to help you get a complete understanding of your new Shark Duoclean® Corded Stick Vacuum with Anti-Hair Wrap Technology.

If you have any questions, please call the customer service line on +44 (0)800 862 0453.



CONTENTS

Important Safety Instructions	1
Important Safety Instructions	3
Assembly	5
Cleaning Modes	6
Storage	7
Available Accessories	8
Maintenance	9
Emptying the Dust Cup	9
Cleaning the Filters	10
Floorhead Maintenance	19
Checking for Blockages	14
Troubleshooting Guide	15
Warranty Terms and Conditions	16



This marking indicates that this product should not be disposed with other household wastes throughout the EU. To prevent possible harm to the environment or human health from uncontrolled waste disposal, recycle it responsibly to promote the sustainable reuse of material sources. To return your used device, please use the return and collection systems or contact the retailer where this product was purchased. They can take this product for environmental safe recycling.

IMPORTANT SAFETY INSTRUCTIONS

HOUSEHOLD USE ONLY

To reduce the risk of electric shock, this vacuum cleaner has a polarized plug (one blade is wider than the other). As a safety feature, this plug will fit into a polarized outlet only one way. If the plug does not fit fully into the outlet, reverse the plug. If it still does not fit, contact a qualified electrician. **DO NOT force into outlet or try to modify to fit.**

⚠ WARNING

TO REDUCE THE RISK OF FIRE, ELECTRIC SHOCK OR INJURY:

GENERAL WARNINGS

1. Your vacuum cleaner may consist of a motorized nozzle, wand, hose, and/or vacuum pod. This device contains electrical connections, electrical wiring, and moving parts that potentially present risk to the user.
2. Use only identical replacement parts.
3. Carefully observe and follow the instructions provided below to avoid improper use of the appliance. **DO NOT** use the vacuum for any purpose other than those described in this manual.
4. Before use, carefully inspect all parts for any damage. **DO NOT** use if any parts are damaged.
5. The use of an extension cord is **NOT** recommended.
6. This vacuum cleaner contains no serviceable parts.

USE WARNINGS

7. **DO NOT** allow the appliance to be used by children. Close supervision is necessary when used near children. This is not a toy.
8. Always turn off the vacuum cleaner before connecting or disconnecting any motorized nozzles or other accessories.
9. **DO NOT** handle plug or vacuum cleaner with wet hands.
10. **DO NOT** use without filters in place.

11. Only use Shark® branded filters and accessories. Failure to do so will also void the warranty.
12. **DO NOT** damage the power cord:
 - a) **DO NOT** pull or carry vacuum cleaner by the cord or use the cord as a handle.
 - b) **DO NOT** unplug by pulling on cord. Grasp the plug, not the cord.
 - c) **DO NOT** run the vacuum cleaner over the power cord, close a door on the cord, pull the cord around sharp corners, or leave the cord near heated surfaces.
13. **DO NOT** put any objects into nozzle or accessory openings. **DO NOT** use with any opening blocked; keep free of dust, lint, hair, and anything that may reduce airflow.
14. **DO NOT** use if nozzle or accessory airflow is restricted. If the air paths or the motorized floor nozzle become blocked, turn the vacuum cleaner off and unplug from electrical outlet. Remove all obstructions before you plug in and turn on the unit again.
15. Keep nozzle and all vacuum openings away from hair, face, fingers, uncovered feet, or loose clothing.
16. **DO NOT** use if vacuum cleaner is not working as it should, or has been dropped, damaged, left outdoors, or dropped into water.

SAVE THESE INSTRUCTIONS

READ ALL INSTRUCTIONS BEFORE USE

17. If the supply cord is damaged, it must be replaced by the manufacturer, its service agent or similar qualified persons in order to avoid a hazard.
18. Use extra care when cleaning on stairs.
19. **DO NOT** leave the vacuum cleaner unattended while plugged in.
20. When powered on, keep the vacuum cleaner moving over the carpet surface at all times to avoid damaging the carpet fibres.
21. **DO NOT** place vacuum cleaner on unstable surfaces such as chairs or tables.
22. Your Shark® vacuum may not be designed to stand up on its own. When taking a break from cleaning, you may need to lean it against furniture or a wall, or lay it flat on the floor. Using the vacuum for an application where the unit lacks stability may result in personal injury.
23. **DO NOT** use to pick up:
 - a) Liquids
 - b) Large objects
 - c) Hard or sharp objects (glass, nails, screws, or coins)
 - d) Large quantities of dust (drywall dust, fireplace ash, or embers). **DO NOT** use as an attachment to power tools for dust collection.
 - e) Smoking or burning objects (hot coals, cigarette butts, or matches)
 - f) Flammable or combustible materials (lighter fluid, gasoline, or kerosene)
 - g) Toxic materials (chlorine bleach, ammonia, or drain cleaner)
24. **DO NOT** use in the following areas:
 - a) Poorly lit areas
 - b) Wet or damp surfaces
 - c) Outdoor areas
 - d) Spaces that are enclosed and may contain explosive or toxic fumes or vapors (lighter fluid, gasoline, kerosene, paint, paint thinners, mothproofing substances, or flammable dust)
25. Turn off all controls before plugging in or unplugging the vacuum.
26. Unplug from electrical outlet when not in use and before any maintenance or cleaning.
27. Hand wash with water only. Washing with cleaning chemicals could damage the unit.
28. During cleaning or routine maintenance, **DO NOT** cut anything other than hair, fibres, or string wrapped around the brushroll.
29. Allow all filters to air-dry completely before replacing in the vacuum to prevent liquid from being drawn into electric parts.
30. Make sure the dust cup and all filters are in place after routine maintenance.
31. If provided, secure the power cord around the two cord hooks during storage.

ASSEMBLY

1. Lift the **Floor Nozzle Tube**, pushing it firmly until it stands upright. The **Retractable Wheels** will extend so the vacuum can stand on its own.
 2. Insert the **Wand** into the floor nozzle tube.
 3. Attach the **Lift-Away® Pod** to the wand.
 4. Snap the **Accessory Holder** onto the wand, then place accessories in the holder.
- Ensure all connections click securely into place.

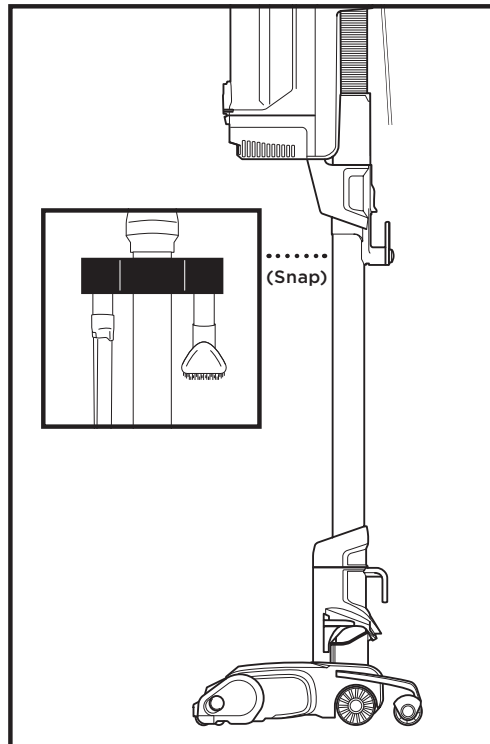
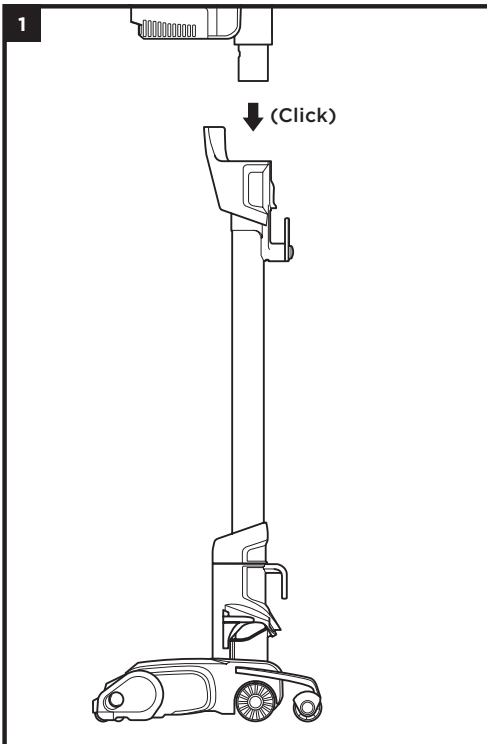
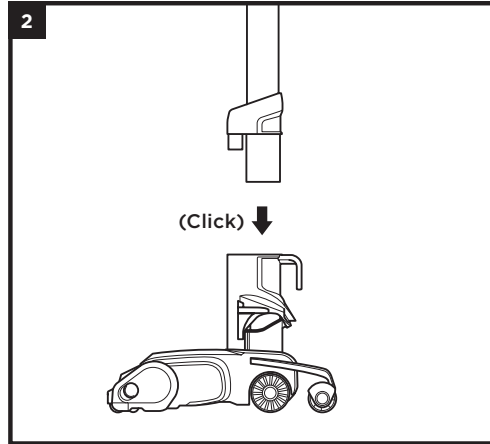
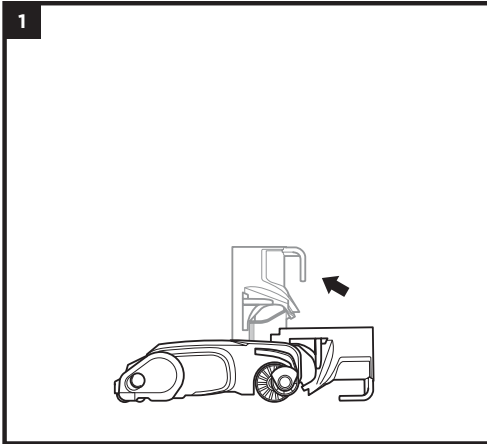

CLEANING MODES

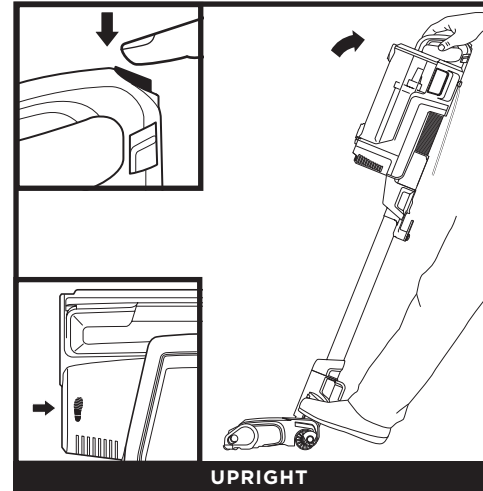

To vacuum in upright mode, plug in the power cord, then press the Power button on the back of the handle. Step on the footprint icon on the floor nozzle and tilt the handle back to activate the brushroll. The retractable wheels will automatically slide back for easy maneuverability while vacuuming.

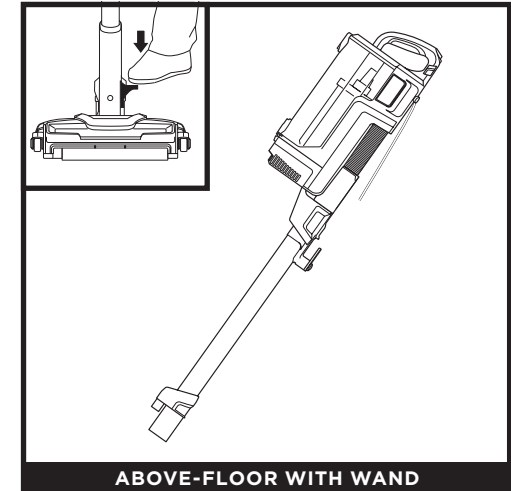

To clean above-floor areas with the wand, remove it from the floor nozzle and add an accessory. To detach the wand, stand the vacuum upright, then step on the release pedal and pull up the wand.

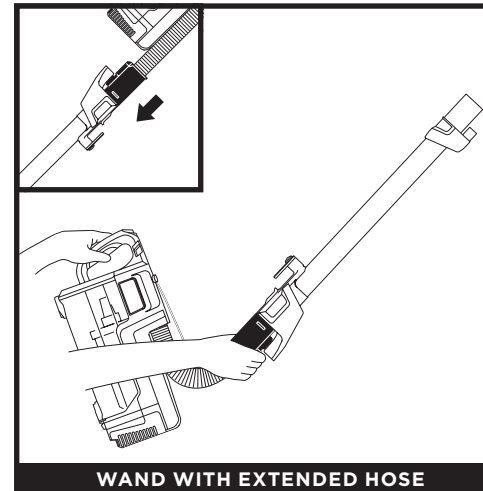

For even more reach and flexibility with the wand, slide the hose cuff down to extend the integrated hose.
NOTE: When finished with the hose, slide the hose cuff back into place while reattaching the wand to the pod.

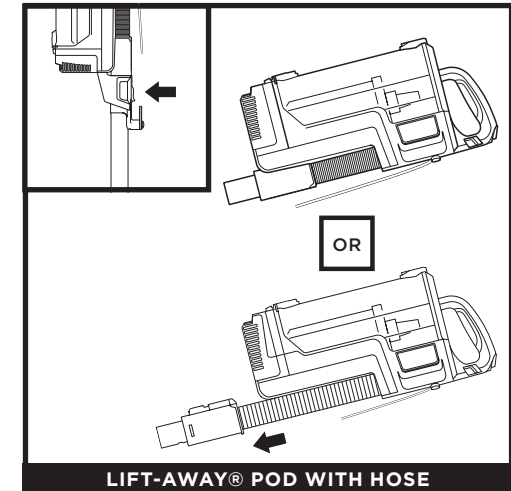

To clean with the Lift-Away pod, detach it by pressing the Pod Release button. Attach an accessory for more reach when cleaning above-floor areas like stairs and furniture. For added flexibility and reach, slide the cuff down to extend the hose.
NOTE: When finished with the hose, slide the hose cuff back into place.

NOTE: Accessories are compatible with both the wand and integrated hose.

STORAGE

STABILITY

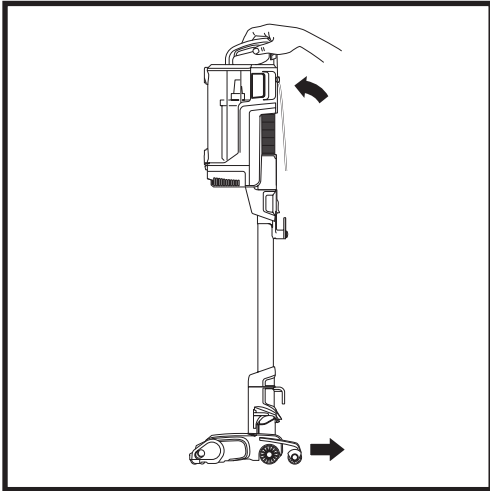

Return vacuum to upright position. The retractable wheels will extend to keep the vacuum in a standing position.

For easy maneuverability in storage mode, tilt the handle back and roll the vacuum on the retractable wheels. To take the vacuum out of storage mode, step on the footprint icon on the floor nozzle and tilt the handle back. The retractable wheels will slide back.

CORD

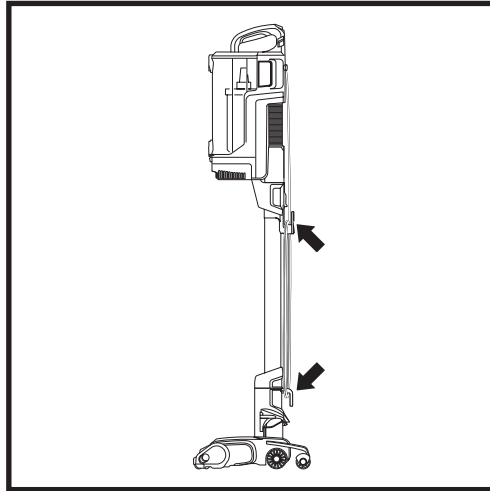

Wrap the cord around the two cord hooks for storage and to avoid damage.

AVAILABLE ACCESSORIES

NOTE: Not all accessories come with all units. Please see the enclosed Quick Start Guide for your unit's configuration. To order additional accessories, visit sharkclean.eu

A 20cm Crevice Tool

This slender 8" tool can access corners, baseboards, tight spaces, and ceilings.



B 30cm Crevice Tool

Clean in tight spaces or reach baseboards and ceilings with this slim crevice tool.

C Dusting Brush

Dust shelves, baseboards, window and door frames, and much more. Turn the brush head to adjust the angle to fit the surface you're cleaning.

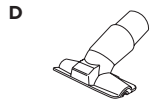
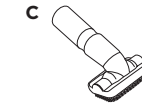

D Pet/Upholstery Tool

Perfect for grabbing pet hair and lint from furniture and other upholstered surfaces.

E Pet Multi-Tool

A single convertible tool for cleaning tough pet messes two ways: first, a stiff bristle brush for cleaning stuck-on debris. Then take off the bristles to reveal an upholstery tool for removing stubborn pet hair.

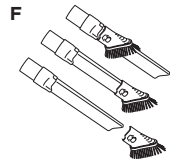
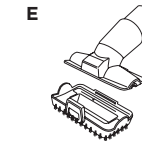

F Duster Crevice Tool

Two cleaning tools in one. The crevice tool gives you extended reach to clean in tight spaces, while the soft brush lets you dust delicate surfaces.

G Anti-Allergen Dust Brush

Features nylon fibre bristles specifically designed for removing fine dust and allergen particles from the most delicate surfaces.

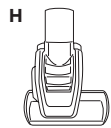
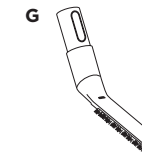

H Self-Cleaning Pet Power Brush

Tackles pet hair and ground-in dirt from above-floor areas like carpeted stairs and upholstery, while actively removing hair wrap as it cleans.

I Accessory Holder

Store accessories onboard the vacuum for ease and convenience.

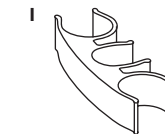

Note: All accessories are compatible with the wand, hose, and pod.

MAINTENANCE

EMPTYING THE DUST CUP

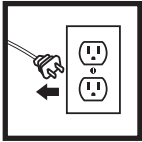

IMPORTANT: Unplug the power cord before performing any maintenance.

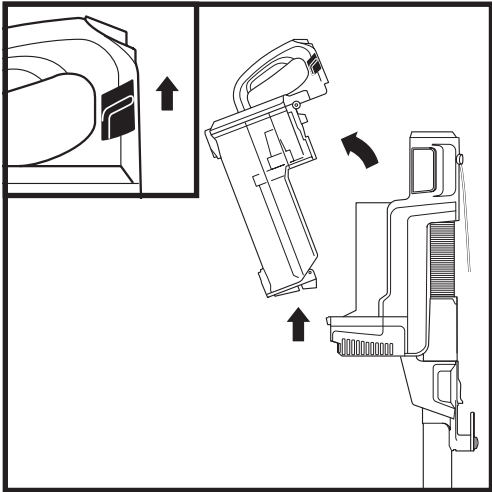

To remove the dust cup from the Lift-Away® pod, slide up both **Dust Cup Release** latches on the back of the handle at the same time and pull out the dust cup.

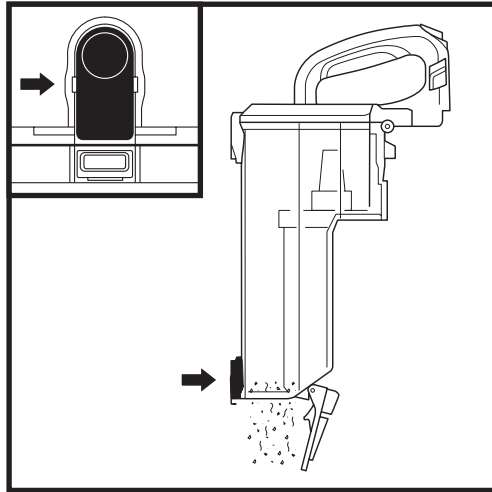

Press the button on the bottom of the dust cup to release debris into the trash.

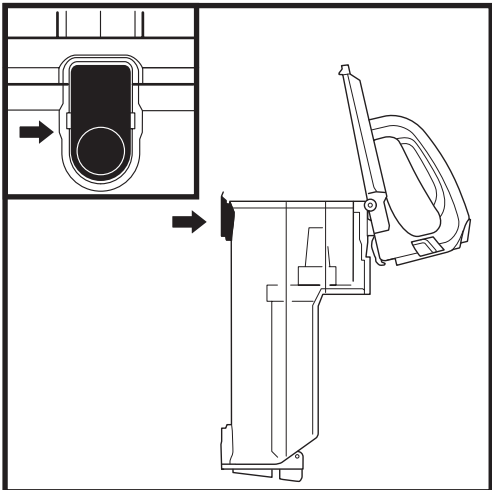

To remove collected debris from **Mesh Screen**, press top release button and lift handle to open.

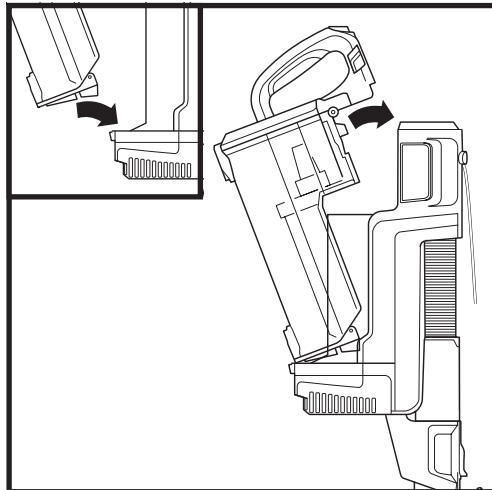

To reinstall, place bottom of dust cup into pod and then tilt it until it clicks into place.

MAINTENANCE

CLEANING FILTERS

Regularly clean and replace the filters to keep your vacuum's suction power optimal.

To clean filters, rinse with cold water only. Allow all filters to air-dry for at least 24 hours before reinstalling them to prevent liquid from being drawn into electric parts.

IMPORTANT: DO NOT use soap when cleaning the filters.

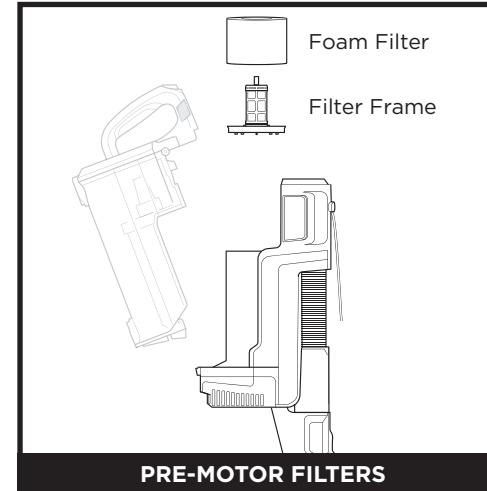

PRE-MOTOR FILTERS

CLEAN PRE-MOTOR FILTERS ONCE A MONTH

Remove **Dust Cup**, then lift out the **Filter Frame**. Pull up the **Foam Filter** to remove it from the filter frame. The **Felt Filter** is built into the support frame.

To reinstall, insert the bottom of the dust cup into the pod and tilt it until it clicks into place.

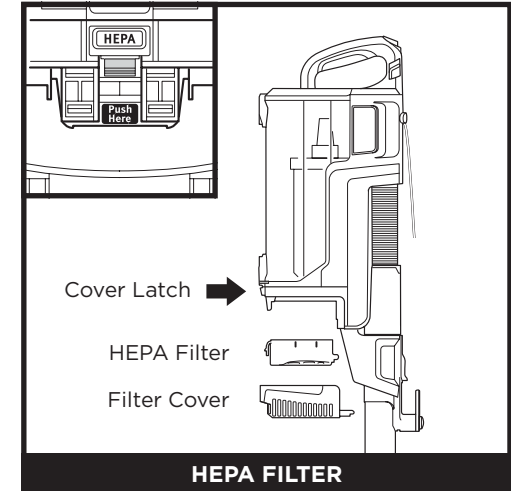

HEPA FILTER

CLEAN HEPA FILTER EVERY YEAR

Press the **Cover Latch** above the **Filter Cover**, then pull off the cover. Push the tab on the front of the cover to detach the **HEPA Filter**.

To replace the HEPA filter, snap it back into the pod, then slide-on the cover until it clicks into place.

REPLACING FILTERS

The **Pre-Motor Filters** should be replaced every 2.5 years. The **HEPA Filter** should be replaced every 3 years.

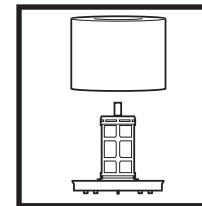

**Replacement
Pre-Motor Foam &
Filter Support Kit**

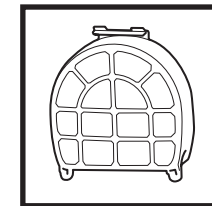

**Replacement
HEPA Filter**

NOTE: To order replacement parts and filters, visit sharkaccessories.com.

MAINTENANCE

FLOORHEAD MAINTENANCE

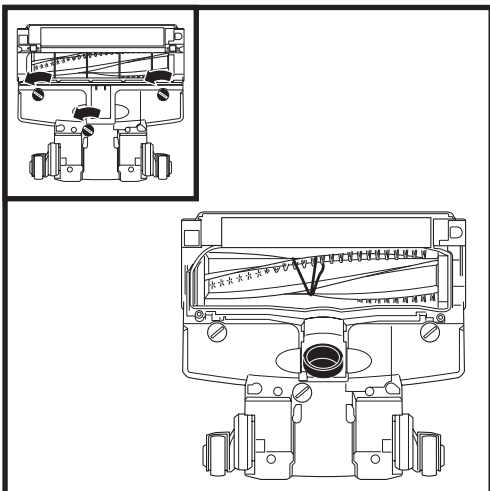

If you notice any hair wrap, continue vacuuming and the **Brushroll** will automatically remove it.

To remove the cover, use a coin to turn the locks counterclockwise. Lift off the cover and remove any debris or hair wrap. Check the **Debris Intake** and clear away any dirt or blockages.

To close the cover, push down until it clicks into place, then turn the locks clockwise until closed.

CLEANING THE SOFT ROLLER

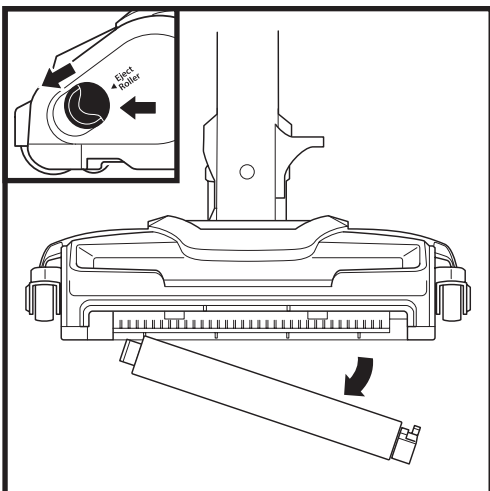

- 1 To remove the Soft Roller, slide the **Eject Roller** button on the floor nozzle.
- 2 Tap loose debris off the Soft Roller. Use a dry towel to wipe it clean, and to remove any debris caught in the teeth behind the Soft Roller.
- 3 Hand-wash the Soft Roller as needed. Use only water, and let it air-dry completely for at least 24 hours.
- 4 Reinsert the Soft Roller and press it in until it clicks securely into place.

NOTE: For best performance, keep the Soft Roller clean with regular maintenance.

MAINTENANCE

CHECKING FOR BLOCKAGES

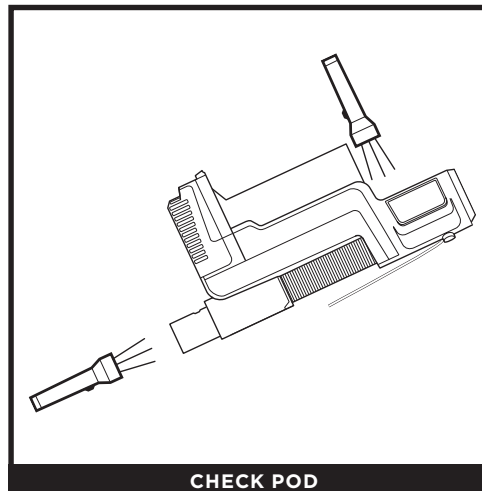

CHECK POD

Remove the dust cup from the pod to check the intake opening inside. Then detach the pod from the wand to check the hose.

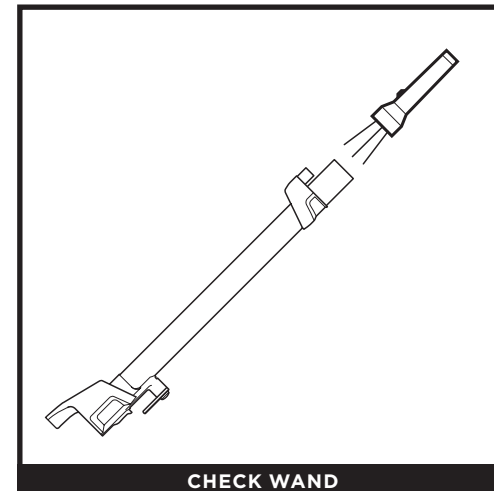

CHECK WAND

Detach the wand and check it for blockages.

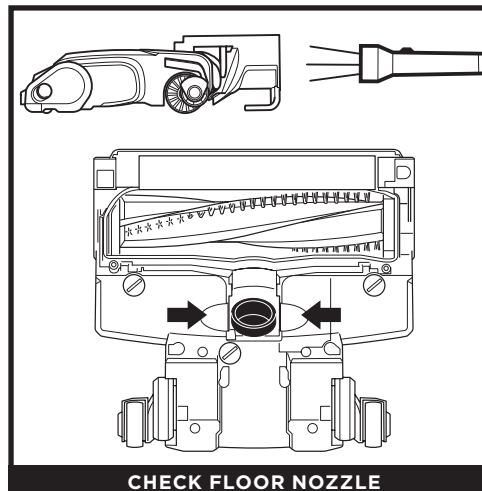

CHECK FLOOR NOZZLE

Detach the wand, then remove the Soft Roller. Tilt the floor nozzle tube back and check openings for blockages. Reinsert Soft Roller until it clicks securely into place.

Remove any blockages or debris from the floor nozzle debris intake (See Nozzle Maintenance section).

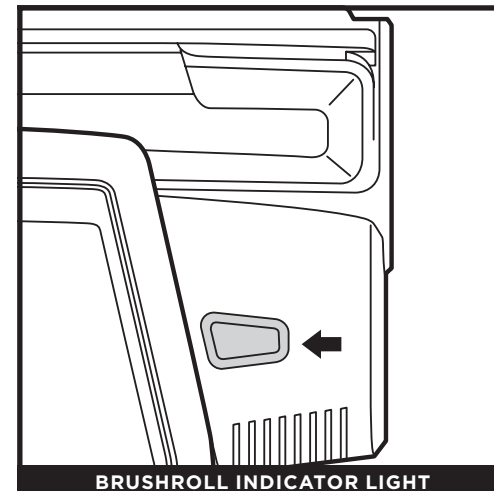

BRUSHROLL INDICATOR LIGHT

What does the **Brushroll Indicator Light** mean?

Solid Green: The brushrolls are spinning and working properly.

Solid Red: There is a jam in the brushroll area. Turn your vacuum off and remove any blockages in the nozzle.

Flashing Red: The motorized floor nozzle is overheating. Turn your vacuum off, unplug from the wall, and wait a minimum of 45 minutes for it to cool down.

TROUBLESHOOTING GUIDE

⚠ WARNING: To reduce the risk of shock and unintended operation, turn power off and unplug unit before servicing.

Vacuum is not picking up debris. No suction or light suction.

(Refer to Maintenance section for more information.)

- Check filters to see if they need cleaning. Follow instructions for rinsing and drying the filters before re-inserting in the vacuum.
- Dust cup may be full; empty dust cup.
- Check hose, hose connections, nozzle, and accessories for blockages; clear blockages if required.
- Remove any string, carpet fibres, or hair that may be wrapped around the brushrolls.

Vacuum lifts area rugs.

- Turn off unit to disengage the brushrolls. Move switch to Hard Floor setting to turn on the slow brushrolls, which is optimal for bare floors and area rugs.
- Suction is powerful. Take care when vacuuming area rugs or rugs with delicately sewn edges.
- To minimise suction, refer to Suction Control section for more information on how to use.

Brushroll/soft roller does not spin.

- If Brushroll Indicator Light on the floor nozzle turns red, the brushroll and/or soft roller have stopped spinning. Immediately turn off and unplug vacuum. Disconnect the nozzle and remove blockage, then reconnect and turn vacuum back on.
- If Brushroll Indicator light repeatedly turns red while vacuuming carpet, try moving Suction Control slide to MIN.
- With the power on, recline the handle, which will automatically turn on the brushrolls.

Vacuum turns off on its own or Brushroll Indicator Light flashes red.

- This vacuum is equipped with a motor-protective thermostat. If your vacuum overheats, the thermostat will automatically turn the suction motor off. Perform the following steps to restart the thermostat:
 1. Turn vacuum off and unplug it.
 2. Empty dust cup and clean filters (see Maintenance section).
 3. Check for blockages in hose, accessories, and inlet openings.
 4. Allow unit to cool for a minimum of 45 minutes.
 5. Plug in vacuum and turn it on.
- If hose is not fully connected to the pod, it can cause a poor electrical connection and the hose can come loose, turning the vacuum off.
 1. Turn vacuum off and unplug it.
 2. Empty dust cup and clean filters.
 3. Check for blockages in hose, accessories, and inlet openings.
 4. Remove cord from cord hook so hose latch can be seen and engaged.
 5. Ensure you hear an audible click at all connection points:
 - a. Where hose meets back of pod (may require additional force; pull on hose to ensure latch is fully engaged)
 - b. Where wand plugs into floor nozzle
 - c. Where handle plugs into wand
 6. Plug in vacuum and turn it on.

Note: If vacuum still does not start, contact Customer Service at +44 (0)800 862 0453.

Shark | NINJA WARRANTY TERMS AND CONDITIONS

When a consumer buys a product in the UK, they get the benefit of legal rights relating to the quality of the product (your "statutory rights"). You can enforce these rights against your retailer. However, at Shark we are so confident about the quality of our products that we give you an additional manufacturer's warranty of up to five years upon registration with Shark. Offer valid only in United Kingdom and Republic of Ireland. These terms and conditions relate to our manufacturer's warranty only – your statutory rights are unaffected.

The conditions below describe the prerequisites and scope of our warranty. They do not affect your statutory rights or the obligations of your retailer and your contract with them.

Shark® Guarantees

A household appliance like a vacuum cleaner constitutes a sizeable investment. Your new machine needs to work properly for as long as possible. The guarantee it comes with is an important consideration – and reflects how much confidence the manufacturer has in its product and manufacturing quality.

Every Shark machine comes with a free parts and labour guarantee. Our customer service helpline (+44 (0)800 862 0453) is open from 9.00am to 6.00pm Monday - Friday. It's free to call, and you'll be put straight through to a Shark representative. You'll also find online support at sharkclean.eu/uk.

How do I register my extended Shark guarantee?

You can register your guarantee online within 28 days of purchase. To save time, you'll need the following information about your machine:

- Date you purchased the machine (receipt or delivery note)
- To register online, please visit sharkclean.eu/uk/register-guarantee
- Serial Number

IMPORTANT

- Both the 12 months and the extended 4 years guarantee will only cover your product from the date of purchase.
- Please keep your receipt at all times. Should you need to use your extended guarantee we will need your receipt to verify the information you have supplied to us is correct. The inability to produce a valid receipt may invalidate your guarantee.

What are the benefits of registering my free Shark guarantee?

When you register your guarantee we'll have your details to hand if we ever need to get in touch. You can also receive tips and advice on how to get the best out of your Shark vacuum and hear the latest news about new Shark® technology and launches.

If you register your guarantee online, you'll get instant confirmation that we've received your details.

How long are new Shark machines guaranteed for?

Our confidence in our design and quality control means that your new Shark vacuum cleaner is guaranteed for a total of five years. (12 months plus an extended warranty of 4 years).

What is covered by the free Shark guarantee?

Repair or replacement of your Shark machine (at Shark's discretion), including all parts and labour. A Shark guarantee is in addition to your legal rights as a consumer.

What is not covered by the free Shark guarantee?

- Blockages – For details of how to unblock your vacuum cleaner, please refer to the Operating Manual.
- Normal wear and tear such as brush bar, fuse, belt, batteries etc.
- Accidental damage, faults caused by negligent use or care, misuse, neglect, careless operation or handling of the vacuum cleaner which is not in accordance with the Shark Operating Manual supplied with your machine.
- Use of the vacuum cleaner for anything other than normal domestic household purposes.
- Use of parts not assembled or installed in accordance with the operating instructions.
- Use of parts and accessories which are not Shark Genuine Components.
- Faulty installation (except where installed by Shark).
- Repairs or alterations carried out by parties other than Shark or its agents.

What happens when my guarantee runs out?

Shark does not design products to last for a limited time. We do appreciate that there may be a desire for our customers to want to repair their vacuum cleaners after the warranty has elapsed. In this case please contact our free phone customer service help line and ask about our out warranty program, on +44 (0)800 862 0453.

Where can I buy genuine Shark spares and accessories?

Shark spares and accessories are developed by the same engineers who developed your Shark vacuum. You'll find a full range of Shark spares and replacement parts for all Shark machines at sharkclean.eu/uk/parts. Accessories are at sharkclean.eu/uk/accessories.

Please remember that using non-Shark spares invalidates your guarantee.



Euro-Pro Europe Limited
Unit 15 Mariner Court
Calder Business Park
Wakefield, West Yorkshire, WF4 3FL
+44 (0)800 862 0453
www.sharkclean.eu

Illustrations may differ from actual product. We are constantly striving to improve our products, therefore the specifications contained herein are subject to change without notice.

SHARK, DUOCLEAN and LIFT-AWAY are registered trademarks of SharkNinja Operating LLC.

© 2019 SharkNinja Operating LLC
HZ400UK_Series_IB_E_MP_190619_Mv1
PRINTED IN CHINA

 [@sharkcleaninguk](https://www.facebook.com/sharkcleaninguk)

 [@sharkcleanuk](https://twitter.com/sharkcleanuk)

 [@sharkcleanuk](https://www.instagram.com/sharkcleanuk)