

You'll soon be enjoying your new DAB/FM Radio.

It all begins here, with your instructions. Don't worry, there's nothing too technical coming up. Just simple, step-by-step guidance to get you up and running quickly. Sound good? Then let's get started.

Help and Guidance

We're here to help you get the most from your DAB/FM Radio. Should you require any guidance, a simple solution can often be found online at:

www.bush-support.com

If you still require further assistance, call one of our experts on **0345 600 3021**.



2 Using your DAB/FM Radio

Let's get started

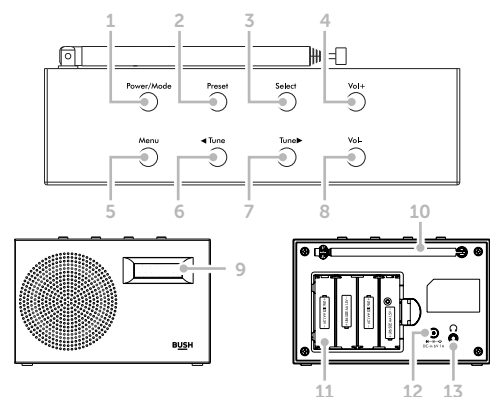

- | | |
|------------------|-------------------------|
| 1. Power/Mode | 8. Volume - |
| 2. Preset | 9. Display |
| 3. Select | 10. Telescopic antenna |
| 4. Volume + | 11. Battery compartment |
| 5. Menu | 12. Power socket |
| 6. Tune/Scroll ◀ | 13. Headphone socket |
| 7. Tune/Scroll ▶ | |

Setting up

1. Connect the mains power lead into the socket on the back of the radio and fully extend the telescopic aerial in a vertical position to obtain the maximum signal strength.
2. Plug the power adaptor into the mains power wall socket and switch on.
3. The display will light up and 'Welcome to Digital Radio' will be displayed.
4. Press and release the Power button. Your radio will switch on and begin an automatic scan for DAB stations. A progress bar will show the progress of the scan and the number of stations found will also be displayed.
5. When the scan is complete your radio will select the first available station and begin to play. Stations are listed in numerical and then alphabetical order by default.

Note: The DAB radio station list is stored in the memory and so the next time you switch your radio on, the station search does not take place.

Inserting the batteries

1. Before installing the batteries (not included) please ensure that the Radio is switched off by pressing and holding the Power button, then unplug the mains power supply.

1 Safety information

Important - Please read these instructions fully before installing or operating

General safety information

- Keep the product and all its parts out of reach of small children.
- This product is not intended for use by persons (including children) with reduced physical, sensory or mental capabilities, or lack of experience and knowledge, unless they have been given supervision or instruction concerning the use of the appliance by a person responsible for their safety.
- Do not attempt to open the product. This product does not contain any user serviceable parts. Unauthorised handling of the device may damage it and will void your warranty.

 To avoid possible hearing damage, do not listen to this radio at high volume levels for long periods of time. Always keep the volume within reasonable limits.

Power source

- Only use the power supply that came with the product. Using an unauthorised power supply will invalidate your guarantee and may irreversibly damage the product.

- If the Radio will not be used for a long period of time, make sure that all of the batteries are removed from the battery compartment and the mains power is unplugged.
- Disconnect your Radio from the mains power supply during electrical or thunder storms.
- Always check that you have completely switched off your Radio, before you change or disconnect the power supply.
- No naked flame sources, such as lit candles, should be placed on the product.
- Do not leave it in high temperatures as electronic devices and plastic parts may warp in heat.
- Do not leave it in low temperatures as moisture can form inside the product, which may damage the circuit board.
- Only use recommended batteries. Do not mix old and new batteries or batteries of different types. Batteries are to be inserted with the correct polarity. The supply terminals are not to be short-circuited.
- Never throw batteries in a fire or attempt to open the outer casing. Do not expose batteries to excessive heat, such as sunshine.
- Batteries are harmful if swallowed, so keep away from young children.

 Danger of explosion if batteries are incorrectly replaced. Replace only with the same or equivalent type.

2. On the back of the radio, push in the tab to release and remove the battery compartment cover.
3. Insert 4 x 1.5V AA-size alkaline batteries, making sure to note the '+' and '-' markings and position the batteries the correct way around.
4. Replace the battery cover, making sure it 'clicks' shut.

For battery operation, please switch off the mains adaptor and remove the mains power plug from the back of the radio.

Telescopic aerial

DAB and FM Radio - please make sure that the telescopic aerial is fully extended. This will ensure that the maximum signal strength is available when the radio is scanning for DAB or FM stations. Extending the aerial also ensures the best possible sound quality.

Power on

Press and release the Power button.

Power off

Press and hold the Power button.

Note: When you Power off the radio when using mains power, it will go to Standby mode. When using batteries, the radio will Power off completely and will not go to Standby mode, to save battery power.

Adjusting the volume

Use the Vol+ button to increase the volume.
Use the Vol- button to decrease the volume.

Change the mode

Press and release the Power button to change between DAB and FM modes.

Headphones

You can connect headphones with a 3.5mm plug (not included) to your radio. The headphone socket can be found on the back of the radio. When you have headphones connected the radio speaker is switched off and all sound is via the headphones.

Changing DAB stations

1. Press and release the ◀ Tune or Tune ▶ buttons to scroll through the available stations in the station list.
2. When the station that you would like to listen to is displayed press and release the Select button. There will be a short delay whilst your DAB radio tunes to your selected station.

Tuning to an FM station

Press and hold the Tune ▶ button to scan up the frequency band.

Press and hold the ◀ Tune button to scan down the frequency band.

Press and release the ◀ Tune or Tune ▶ buttons to fine tune each frequency in 0.05MHz steps.

Storing a DAB or FM station preset

Your radio can store up to 20 radio stations (10 DAB and 10 FM) in its preset memories for instant access to your favourite stations.

In DAB or FM mode:

1. Tune your radio to the station that you wish to preset.
2. Press and hold the Preset button until '<Preset Store <1: (Empty) >' is displayed, if no previous station has been stored.
3. Press and release the ◀ Tune or Tune ▶ button to scroll to the preset location that you would like to store the radio station to (1-10).
4. Press and release the Select button, the display will confirm 'Preset X stored', where 'X' is the number of the preset (1-10).

Note: If there is already an existing DAB or FM station stored under a preset, it will be overwritten when you store the new station.

Tune to a DAB or FM preset station

In DAB or FM mode:

1. Press and release the Preset button.
2. 'Preset Recall <1: >' is displayed and the name or frequency of the station stored there, or '(Empty)' if no previous station has been stored.
3. Press and release the ◀ Tune or Tune ▶ button to scroll to the preset location and station that you would like to listen to (1-10).
4. Press and release the Select button. The radio will tune to that station and begin to play.

Radio display information

When listening to a DAB or FM radio station you can change the information that will appear on the second line of the display. There are several different types of information that are sent by the broadcaster.

1. Repeatedly press and release the Menu button to cycle through the different information options.

Using the Menu

Within the Menu of your product, you will find settings that you can change such as the backlight, as well as a Sleep timer and dual Alarm. In DAB mode, you can also rescan for DAB stations if you have moved your radio, or to make sure that you have the most up to date station listing stored within the memory of your radio.

4 Product support

Help is always at hand

Help and assistance

If you require any technical guidance or find that your DAB/FM Radio is not operating as intended, a simple solution can often be found in the Troubleshooting section of these instructions or online at www.bush-support.com

If you still require further assistance, call one of our experts on

0345 600 3021*

Local call rates applies*

Lines open 8am-7pm Monday to Saturday and 10am-4pm Sunday.

*Calls to Bush enquiry lines may attract a charge and set up fee from residential lines depending on your call plan/tariff. Mobile and other providers costs may vary, see www.bt.com/pricing for details.

For Security and training purposes, telephone calls to and from customer service centres may be recorded and monitored. Calls from Republic of Ireland will attract international call charges.

Troubleshooting

Radio reception is poor

- Fully extend the telescopic aerial.
- Rescan for radio stations.
- Try moving your radio to another location to see if reception improves.
- Visit www.digitalradionow.com for information about DAB reception in your area.

Disposal

- Disposal of your old product. Your product is designed and manufactured with high quality materials and components, which can be recycled and reused.
- When this crossed out wheeled bin symbol is attached to a product it means the product is covered by the European Directive 2012/19/EC..
- Please make yourself aware of the local collection system for electrical and electronic products.
- Please act according to your local rules and do not dispose of your old products with your normal household waste.
- The correct disposal of your old product will help prevent potential negative consequences for the environment and human health.

To use the Menu in DAB or FM mode:

1. Press and hold the Menu button.
2. Use the ◀ Tune and Tune ▶ buttons to scroll through the options available.
3. Press and release the Select button to choose or confirm an option.
4. Repeatedly press and release the Menu button until you return to the station display.

Stop the Alarm

If you have set an alarm, when the alarm sounds press and release the Power button to stop the Alarm., 'Alarm Off' will be displayed. Alternatively, you can press and release the Select button to Snooze (see Snooze function below).

Snooze

When the alarm sounds, you can press and release the Select button to snooze for 9 minutes. A snooze time countdown will be displayed until the alarm sounds again.

3 Other information

Helpful technical information

Technical specification



Please use only the specified external adapter DongGuan Obelieve Electronic Co.,Ltd., Model number: OBL06-0601000dB.

Power adaptor: Input: 100-240V 50/60Hz

Output: 6V 1A

Batteries (not supplied): 4 x 1.5V AA size

Headphone socket: 3.5 mm

Frequency range: DAB: Band III, 174MHz to 240MHz

FM: 87.5MHz to 108MHz



This product is intended for use within the UK. This equipment complies with the essential requirements of the Radio Equipment Directive 2014/53/EU.

Declaration of Conformance

Hereby, Argos Ltd, declares that this DAB/FM Radio BD1709 is in compliance with the essential requirements and other relevant provisions of the Radio Equipment Directive 2014/53/EU. The complete declaration of conformity can be obtained by contacting <http://www.bush-support.com/>

BUSH

Call us now and register your 12 month guarantee

Thank you for choosing Bush. Your new product is guaranteed against faults and breakdowns for 12 months. Don't forget to register it with us today so we can provide you with our best possible after-sales service and useful updates.

www.bushregistration.co.uk

FREEPHONE*

0800 597 8548

Lines are open 8am - 8pm, 365 days a year.

*Calls may be recorded and monitored.

Your Bush Guarantee

This product is guaranteed for twelve months from the date of original purchase. Any defect that arises due to faulty materials or workmanship will be repaired free of charge (or if applicable the product will be replaced or the purchase price refunded) where possible during this period by the dealer from who your purchased the unit.

The guarantee is subject to the following provisions:

- The guarantee does not cover accidental damage, misuse, cabinet parts, knobs or consumable items.
- The product must be correctly installed and operated in accordance with the instructions contained in the manual.

- It must be used solely for domestic purposes. The guarantee will be rendered invalid if the product is re-sold or has been damaged by inexpert repair.
- Specifications are subject to change without notice.
- Bush disclaim any liability for loss or damage arising from the breakdown of the product.
- This guarantee is in addition to and does not diminish your statutory or legal rights.

Guarantor: Argos Limited - 489 - 499 Avebury Blvd. - Milton Keynes - MK9 2NW

Important Data Protection Information

If you provide us with information about another person, you confirm that they have appointed you to act for them, to consent to the processing of their personal data including sensitive personal data and that you have informed them of our identity and the purposes (as set out in the Important Data Privacy notice displayed overleaf) for which their personal data will be processed.

You are entitled to ask for a copy of the information we hold about you (for which we may charge a small fee) and to have any inaccuracies in your information corrected.

For quality control and training purposes, we may monitor or record your communications with us.

If your personal details change, if you change your mind about any of your marketing preferences or if you have any queries about how we use your information, please let us know by contacting our Data Protection

Officer, Domestic & General, Leicester House
17 Leicester Street, Bedworth, Warwickshire
CV12 8JP.