



A	CKBSH-A03		重要度	[B]							
B	<h3 style="margin: 0;">技术要求</h3> <ol style="list-style-type: none"> 1. 颜色要求：封面：黑白印刷 内页：黑白印刷； 批量时要求统一，不能有明显色差， 2. 版面内容：封二印内容， 6-8页大写字高需大于3mm 图案与文字应印刷清晰、 规范，不能有印刷缺陷； 3. 页面印刷：双面印刷； 4. 成型方式：骑马钉； 5. 成品尺寸：A5 (140X210) 尺寸公差按GB/T 1804-c； 6. 批量生产前须送样确认。 										
C											
D											
借(通)用件登记									封面：80g双胶 内页：80g双胶	广东奥马冰箱有限公司	
出图审查	标志	处数	更改文件号	签名	日期	重量	比例	说明书			
日期	设计	制图	黄英婷	标准化	刘金利	共 1 张 第 1 张		CKBSH-A03			
	审核	温淦仙	批准	李梅方	日期	视角符号	 				
	工艺				2016-08-12						
	1	2	3	4							

BUSH

Instruction Manual

M58



You'll soon be enjoying your new refrigerator.

It all begins here, with your instructions. Don't worry, there's nothing too technical coming up. Just simple, step-by-step guidance to get you up and running quickly. Sound good? Then let's get started

Help and Guidance

We're here to help you get the most from your refrigerator. Should you require any guidance, a simple solution can often be found online at.

www.argos-support.co.uk

If you still require further assistance, call one of our experts on 0345 257 7271.

Contents

1	Safety information		
	Safety information	6	
2	Getting to know your refrigerator		
	Ready?Let's begin...	11	
	Parts	12	
3	Installing your refrigerator		
	Transportation	15	
	Installation	15	
	Door Reverse	16	
	Electrical Connection	17	
4	Using your refrigerator		
	Before first use	20	
	Using your appliance	20	
	Useful information	20	
5	Care and Maintenance		
	General	24	
	Light bulb replacement	24	
	Vacation	24	
	Moving your appliance	24	
	Technical Specifications	25	
6	Product support		
	Trouble Shooting	28	
	Help and assistance	29	
	Guarantee	30	

Safety information

1

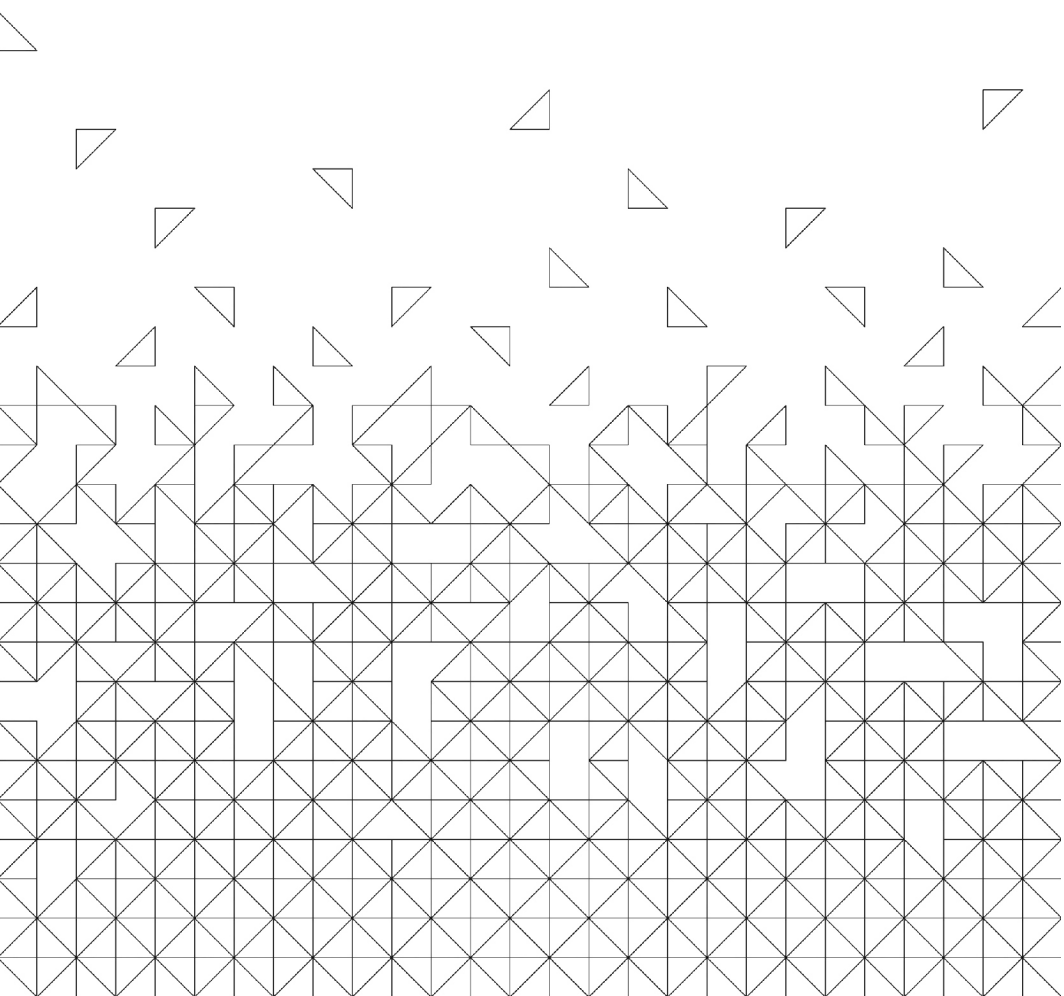



Safety information

Important-Please read these instructions fully before installing or operating

Before use

The installation of this appliance is best carried out by 2 people.

- Dispose of all packaging carefully and responsibly.
- The appliance is designed for **indoor use only** and must be protected from rain, moisture and extreme temperature variations.
- This appliance is designed for house hold use. **Do not** use the appliance for industrial and commercial use, or any other purpose.
- The appliance **MUST** be positioned on a firm level base.
- **Do not** splash water on the appliance. It may cause electrical parts to fail and result in an electric shock.
- Leave the appliance in its intended place of installation and in its correct orientation for at least 4 hours before switching on to allow the cooling system to settle before first use or after any transportation.
- Your appliance is an environmental friendly product and it contains non CFC/HFC gas substances in the cooling system (Called R600a) and in the insulation (Called cyclopentane) which are potentially flammable if exposed to fire. Therefore, take care not to damage, the cooling circuit/pipes of the appliance in transportation and in use. In case of damage do not expose the appliance to fire,



Safety information

Important-Please read these instructions fully before installing or operating

potential ignition source and immediately ventilate the room where the appliance is situated.

- **Do not** sit, stand or place any other heavy objects on top of the appliance. This could result in injury or damage to the appliance.
- **Do not** allow children to play with the appliance to avoid the risk of entrapment and suffocation.
- Keep ventilation opening, in the appliance enclosure or in the built-in structure, clear of obstruction.

During use

- This appliance is not intended for use by persons (including

children) with reduced physical, sensory or mental capabilities, or lack of experience and knowledge, unless they have been given supervision or instruction concerning use of the appliance by a person responsible for their safety. Children should be supervised to ensure that they do not play with the appliance.

- This appliance is not intended for use by young children or infirm persons unless they have been adequately supervised by a responsible person to ensure that they can use the appliance safely. Young children should be supervised to ensure that they do not play with the appliance.
- **Do not** use mechanical,



Safety information

Important-Please read these instructions fully before installing or operating

electrical or chemical way to speed up the defrost process not recommended by the manufacturer.

- **Do not** use or place other electrical products inside the appliance not recommended by the manufacturer.
- **Do not** store liquids in glass containers in the freezer compartment as these may shatter.
- **Do not** store flammable materials such as alcohol, gasoline, LP gas or glue etc in the appliance.
- In case there is an inflammable gas leaking, open the window for air circulation and do not pull out the plug or turn the temperature knob. **Do not** touch the appliance until the valve of gas is turned off. Otherwise, sparks may happen.
- This appliance can be used by children aged from 8 years and above and persons with reduced physical, sensory or mental capabilities or lack of experience and knowledge if they have been given supervision or instruction concerning use of the appliance in a safe way and understand the hazards involved. Children shall not play with the appliance. Cleaning and user maintenance shall not be made by children without supervision.
- **Do not** attempt to repair the appliance yourself. Contact the Customer Helpline:0345 257 7271.



Getting to know your refrigerator

2

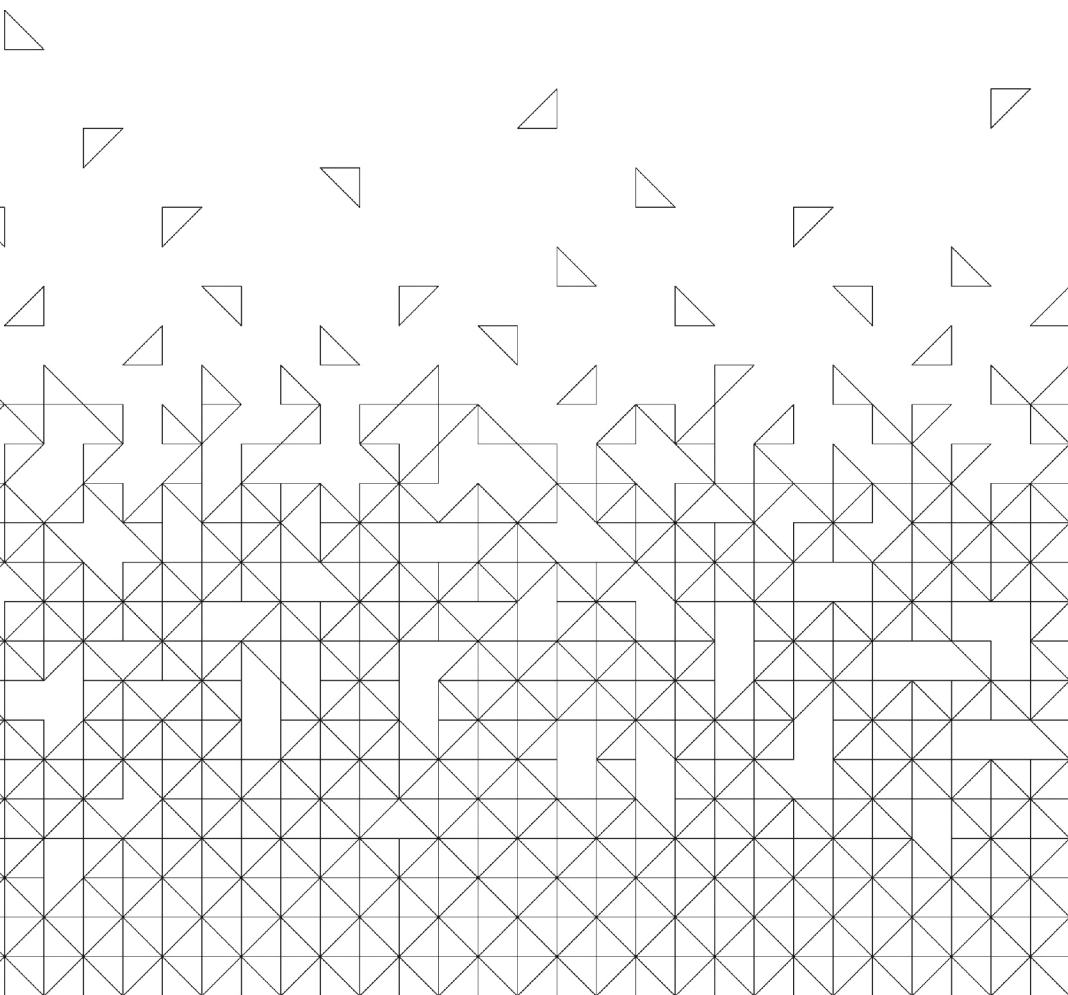

Getting to know your refrigerator

You'll be up and running in no time

Ready? Let's begin...

Please read these instructions carefully. They contain important information which will help you get the best from your refrigerator and ensure safe and correct installation and operation

If you require any further assistance, our technical experts are happy to help. For full details, refer to the product support section at the end of these instructions.

Getting to know your refrigerator

You'll be up and running in no time

Parts

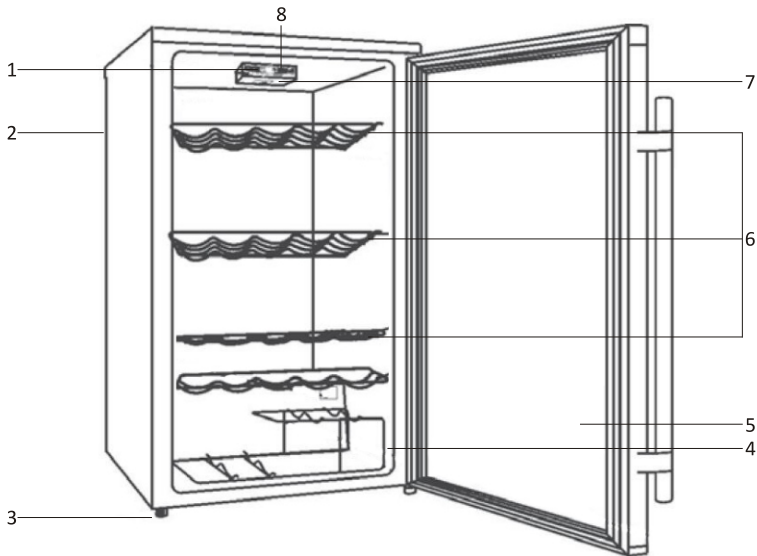

- 1. Lamp Switch
- 2. Cabinet
- 3. Levelling Legs
- 4. Wine Rack

- 5. Glass Door
- 6. Shelves
- 7. Interior Lamp
- 8. Thermostat knob

Accessories included



Instructions x 1



Handlex1



Screws x 2



Installing your refrigerator **3**

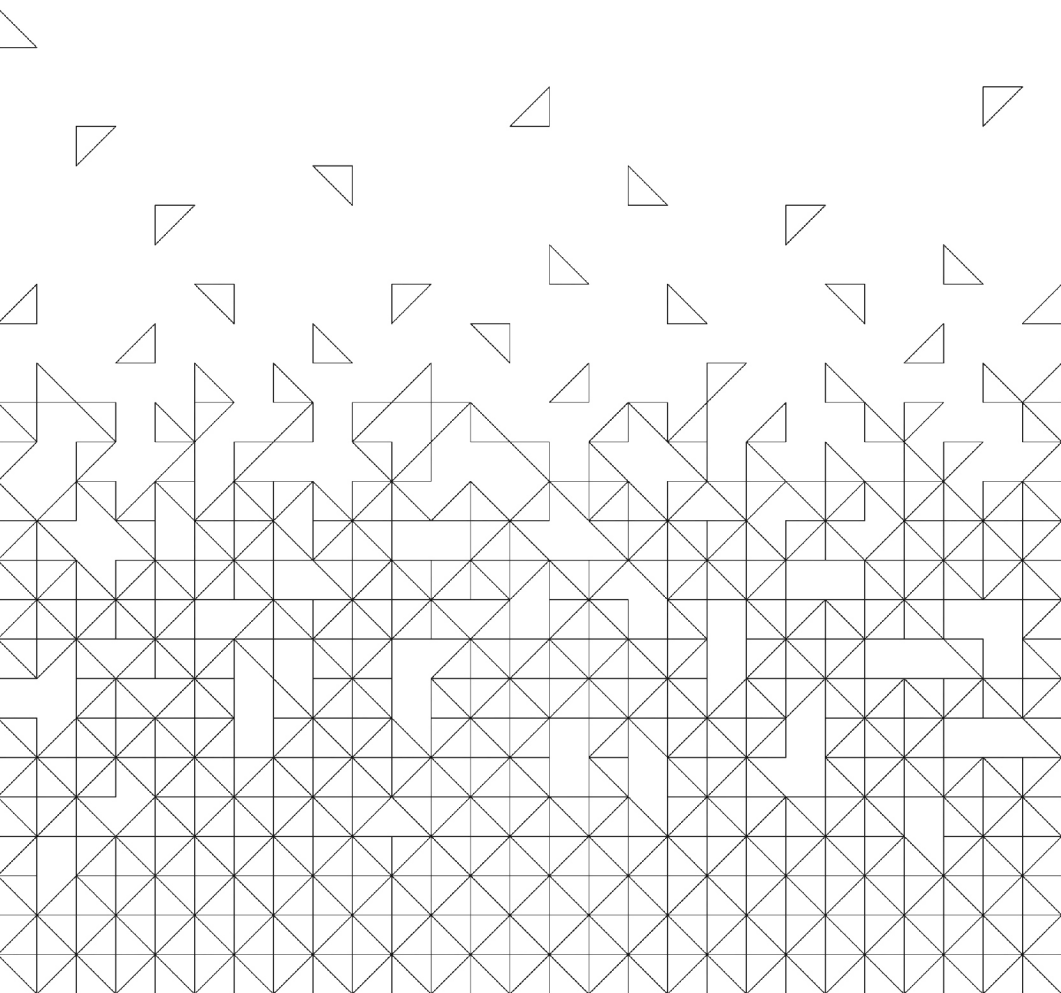

Installing your refrigerator

Bringing it all together

Transportation



Caution: 2 people are required to unpack and handle the appliance, it is recommended that gloves are worn.

- The appliance should be transported only in an upright position. Do not tilt the appliance greater than 45 degrees. The packaging as supplied must be intact during transportation.
- After transporting the appliance, leave it for at least 4 hours before switching on to allow the cooling system to settle. Failure to comply could result in damage to the appliance.
- Do not move the appliance by pulling the door or handle as it may damage your flooring and wall coverings etc.
- Empty any water in the drain tray before moving.
- Make sure that the defrost water pipe at the back of the product is fixed to the plastic evaporating pan on the top of the compressor to avoid defrost water spillage on the floor.
- Ensure the supply cable is not caught under the appliance during and after moving.
- Carefully remove all packaging materials including the foam base, dispose of correctly

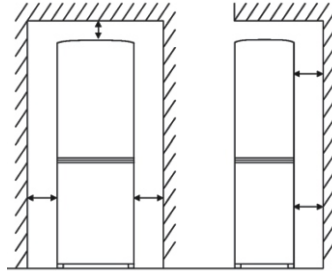

Installation

- Ensure sufficient spacing is provided for the appliance to be installed. Leave space on both sides (15cm), back (20cm) and above the appliance (30cm) to ensure proper ventilation.
- Screw in the two spacers at the back of the appliance.
- Do not place the appliance near a heat source or in direct sunlight.
- Do not put any heavy objects on top of the appliance. It will damage the appliance.
- Do not install the appliance in a moist and wet place.
- Adjust the feet at front to level the appliance. It should be installed on a smooth surface to avoid excessive vibration and noise.
- Each appliance has a climate class (shown on the rating plate) where it indicates the temperature range of the appliance operation in place. The appliance may not work properly if it is left for a long period at a temperature outside the specified range.
- Refer to section “Care and Maintenance” to prepare your appliance for use.

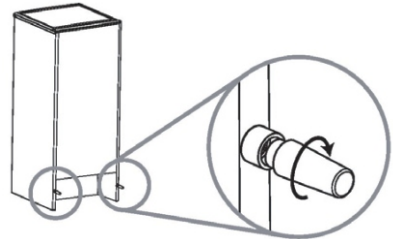

Climate Class	Amb.T.(°C)	Amb.T.(°F)
SN	10~32°C	50~90°F
N	16~32°C	51~90°F
ST	16~38°C	61~100°F
T	16~43°C	61~110°F

Installing your refrigerator

Bringing it all together

Install the handle

1. Remove the handle and screws from the packaging
2. Open the door and align the two screws holes on the handle to the screw holes on the side of the door.
3. Fix the screw to holes to fix the handle in place.
4. Ensure the handle is fixed securely before use.

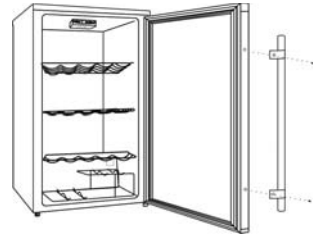

Door Reverse



Warning: Remove the main plug before reversing the door. 2 people may be required to reverse the door.

1. Unscrew the two screws for fixing the handle and remove the handle in safe place.
2. Remove the upper hinge cover (6).
3. Remove the two screws (1) that hold the upper hinge (5) (right side) to the frame. Take away the upper hinge (5).
4. Lift the door and place it on a padded surface to prevent scratching it.
5. Remove the two screws (8) that hold the lower hinge (2) and make sure to remove the lower hinge (2).
6. Remove the left front leg (4) and transfer it to the right side.
7. Remove the hole cover plate (7) to the right sides.
8. Before placing this lower hinge (2), remove the bolt-pin (9) and reverse the direction of the lower hinge (2). Then install the lower hinge (2) onto the left side of the lower hinge (2) onto the left side of the lower frame with two screws (8).
9. Insert the bolt-pin (9) to the lower hinge (2).
10. Set the door to its place making sure the door seat at the lower hinge (2).
11. While holding the door in the closed position, secure the upper hinge (5) in the top frame of left side with two screws (1). Place remember that do not tighten the two screws (1) until the top of the door is levelled with the counter top.
12. Install the upper hinge cover (6) on the upper hinge.
13. Open the door and align the two screw holes on the handle to the screw holed on the side of the door.
14. Fix the screw to the holes to fix the handle in place.

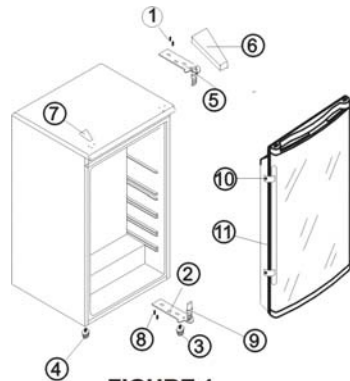

FIGURE 1

Door opening from the left side

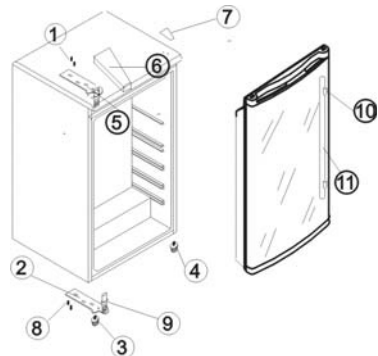

FIGURE 2

Door opening from the right side

Installing your refrigerator

Bringing it all together

Electrical connection



Any electrical work that is required to install this appliance MUST be carried out by a qualified electrician.



Warning: THIS APPLIANCE MUST BE EARTHED

Before making any electrical connections, ensure that:

- Electrical safety is only guaranteed when the earth system of your house is in accordance with the related local regulations.
- Do not damage the refrigerant circuit.
- Do not bend, stretch or pull the supply cable to avoid electric shock.
- Do not use electrical appliances inside the food storage compartments of the appliance, unless they are of the type recommended by the manufacturer.
- Ensure the power socket is suitable for the maximum power of the machine (fuses in the power circuit must be 13 amp).
- The supply voltage should be the same as that indicated in the technical specifications and the appliance rating plate.
- The appliance should be earthed and in compliance with the applicable law.
- When installed, the power socket must be within easy reach.
- If the socket outlets in your home are not suitable for the plug supplied with this unit check with a qualified electrician for replacement.
- The use of adapters, multiple connectors or extension cables are not recommended.
- The appliance must be connected to a 220-240 volt 50Hz AC supply by means of a three pin socket, suitably earthed and protected by a 13 amp fuse.
- Should the fuse need to be replaced, a 13 amp fuse approved to BS1362 must be used.
- The plug contains a removable fuse cover that must be refitted when the fuse is replaced. If the fuse cover is lost or damaged, the plug must not be used until a replacement cover has been fitted or the plug is replaced.
- A damaged plug should be cut off as close to the plug body as possible, the fuse should be removed and the plug disposed of safely.

Plug replacement (UK & Ireland only)

Should you need to replace the plug; the wires in the power cable are coloured in the following way:

Blue Neutral 'N'

Brown Live 'L'

Green & Yellow Earth 'E'

As the colours of the wires in the power cable may not correspond with the coloured markings identifying the terminals in your plug, and proceed as follows:

The green & yellow wire must be connected to the terminal in the plug that is marked with the letter E or by the earth symbol.

The blue wire must be connected to the terminal that is marked with the letter N.

The brown wire must be connected to the terminal that is marked with the letter L.

If the power supply cord is damaged, it must be replaced by the manufacturer or its service agent or a similar qualified person in order to avoid a hazard.

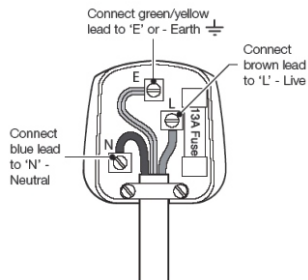

Using your refrigerator 4

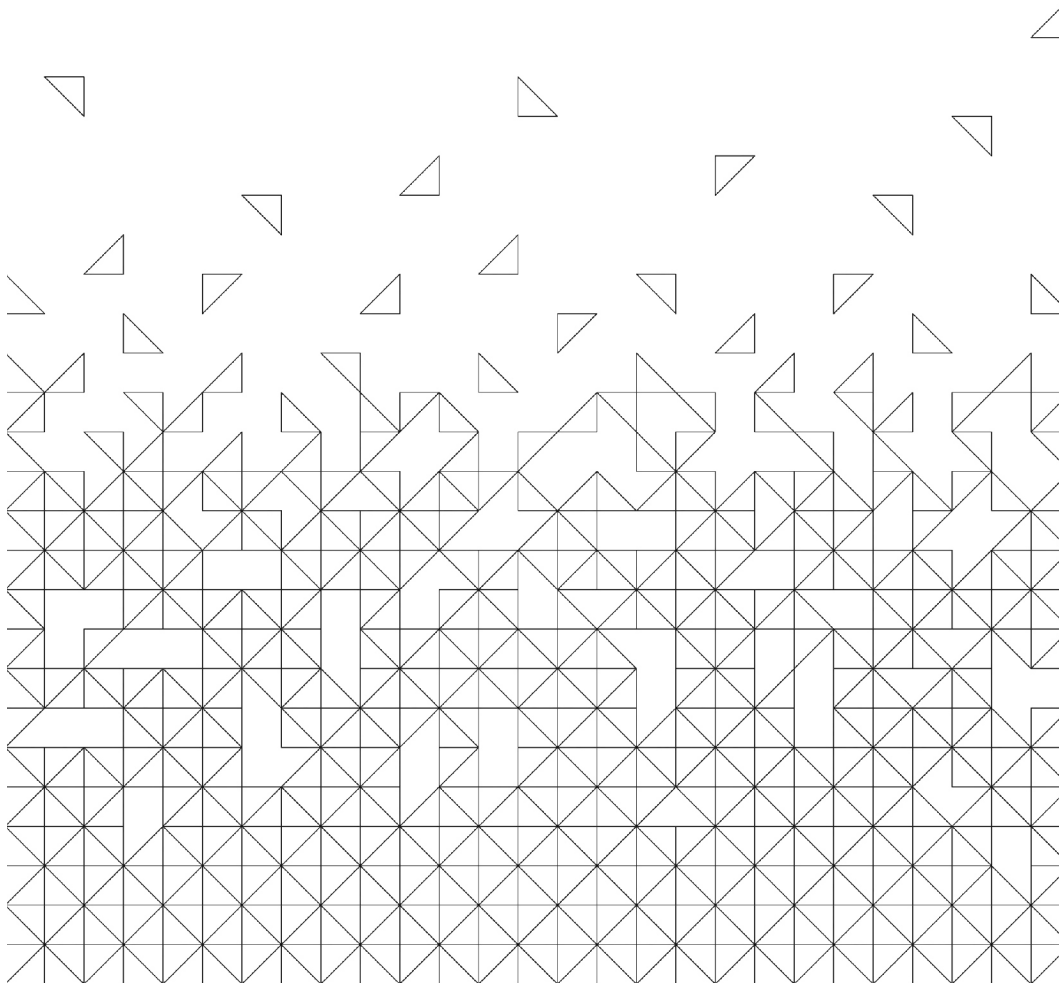

Using your refrigerator

Getting the most from your appliance

Before first use

Final checks before operating the appliance

1. Good air circulation around the appliance positioned.
2. The feet have been adjusted for perfect levelling.
3. Clean the compartment per recommendation in section “Care and Maintenance”.
4. Plug in the appliance and it will start operation to the default temperature setting.



The compressor starts up and in operation may produce some background noise and it is normal, this is not a defect.

How to use the thermostat

- Turn the thermostat knob, you can adjust the temperature of the compartment you desired. Turn it clockwise, the temperature of the compartment will become cooler and cooler. To store red wine you can adjust it anti-clockwise, to store white wine you can adjust it clockwise.

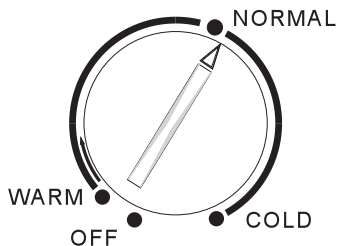

Storing Wine

- Before putting the wine into the wine chiller, please ensure the shelf and rack are placed in place.
- Adjust the temperature of the wine chiller.
- Fill the wine chiller with your choice of wine bottle. Handle them with care.
- Allow 1 to 2 hours to let bottles to reach the desired temperature.
- Do not exceed the capacity that the appliance able to handle.



Condensed water may be found on the glass door during the summer time or humidity season. This is normal. Wipe it with damp cloth.

Useful information

The following guidelines and recommendations are suggested to obtain the best results and storage hygiene.

- Frequent door openings can cause internal temperature rise so the door shall be closed as soon as possible after use.
- For hygiene reasons, it is always a good practise to clean the bottle with damp cloth before storing.
- **Do not** store food, as the interior temperature is not cool enough to prevent spoilage.

Using your refrigerator

Getting the most from your appliance

Energy saving tips

- Place your fridge away from direct sunlight, your oven or any other heat sources. Allow 20 cm clear space on both sides and above, and at least 5 cm behind.
- Cover all food stored, and arrange it so that cold air can circulate freely.
- Higher cold setting will use more energy. Do not set to maximum cold if it is not necessary.
- Cool the hot/warm food to room temperature before put them into your fridge.
- Frequently opening and closing the door will cause the internal temperature to rise and it will consume more energy.
- Close the door(s) properly, and make sure the seals and hinges are airtight. Check the seals by putting a sheet of paper between the door and the main body of the fridge. If the paper moves, your seals need replacing.
- Defrost regularly if your refrigerator is not a frost-free or cyclic defrost model. Accumulated ice layer should not be more than 5 mm thick.
- The pre-set combination of drawers, baskets and shelves have already been set in the most efficient way for the use of this product.

Care and Maintenance 5

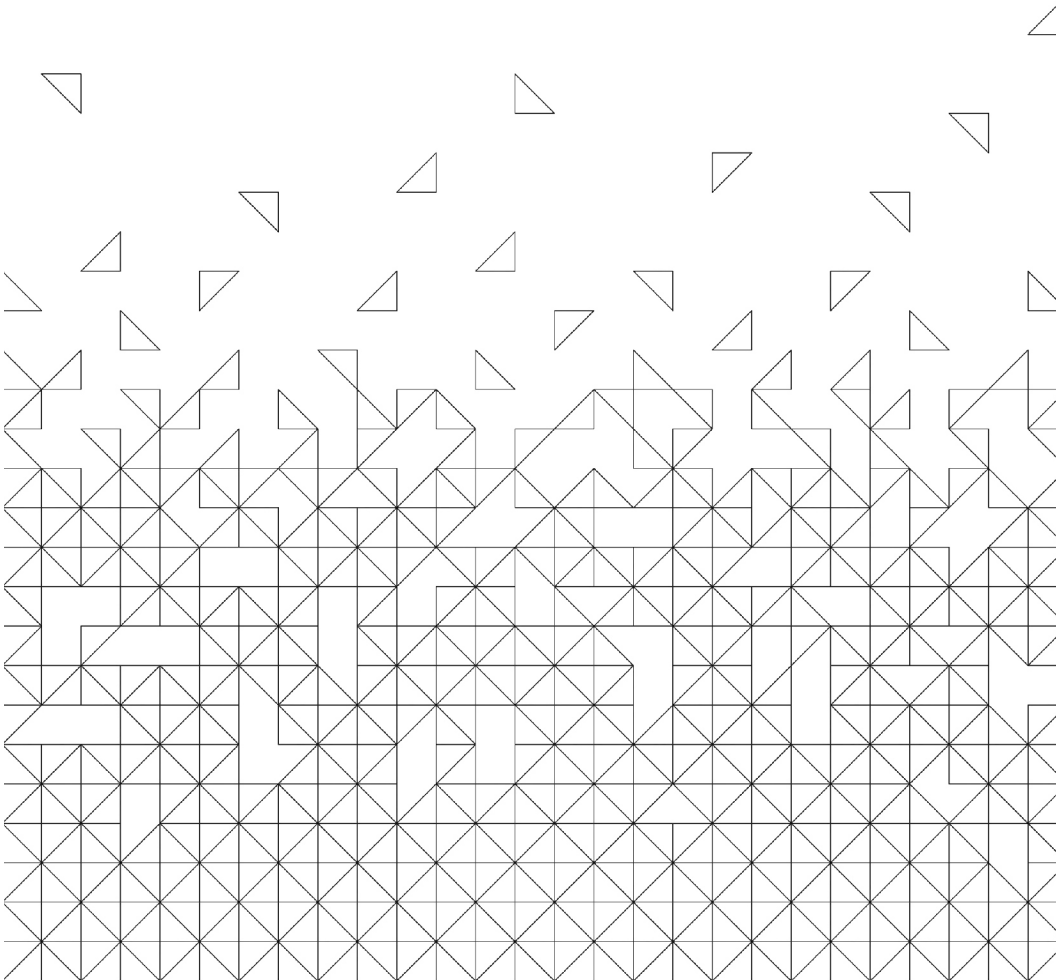

Care and maintenance

Looking after your appliance

General



Important: Always unplug the appliance from the power socket during cleaning and maintenance.

- Never use any sharp instruments or abrasive substances, soap, household cleaner, detergent or wax polish for cleaning.
- Use luke warm water to clean the cabinet of the appliance and wipe it dry.
- Never clean the appliance with flammable fluids. It could cause damage and a fire hazard.
- Clean the exterior of the appliance and door seal with a damp cloth and dry it through.
- Avoid water going into the temperature control box.. Clean with a dry cloth only.
- Clean the condenser (located at the back of the appliance) with a vacuum cleaner. It is suggested to remove the dust every year.
- Shelves are all removable for cleaning purpose.



Important: Care must be taken while cleaning/carrying the appliance not to touch the bottom of the condenser metal wires at the back of the appliance, as this could cause injury to fingers and hands.

Light bulb replacement

The internal light is a LED type. To replace the lamp, please contact qualified technician.

Power failure

In case there is a power failure, you should contact the electricity supply company and take the following actions:

If it is last within 24 hours, keep the doors closed. This will allow the stored bottles to stay cold as long as possible.

If it is last more than 24 hours, it is advised to empty the wine chiller compartment and temporarily store the bottles in a portable wine chiller or using artificial ice packs.

Remarks: Full appliance will stay cold longer than a partially filled one.

Vacation

Short vacation

There is no need to disconnect the appliance from the mains if you will be away for two to three weeks. Use up the perishable food.

Long vacation

Remove all the food if you are away for three weeks or more. Unplug the appliance and leave the doors open to provide air circulation to prevent odour and mould.

Moving your appliance

Moving

Refer to section “Transportation” under “Installation”

Care and maintenance

Looking after your appliance

Technical Specifications

Model	M58
Net storage volume fresh food (litres)	115
Total net storage (litres)	115
Climate class	N
Operating noise level dB(A)	41
Mimum Operation Temperature	16°C

Disposal information



The symbol on the product or its packaging indicates that this product may not be treated as household waste . Instead it should be handed over to the applicable collection point for the recycling of electrical and electronic equipment , By ensuring this product is disposed of correctly, you will help prevent potential negative consequences for the environment and human health , which could otherwise be caused by inappropriate waste handling of this product . For more detailed information about recycling this product , please contact your local council office , your household waste disposal service or the shop where the product was purchased .

Remember : Old fridges must be disposed of carefully - older models contain CFC gases that are harmful - if in doubt , contact your local council for details on how to dispose of an old fridge .

Product support 6

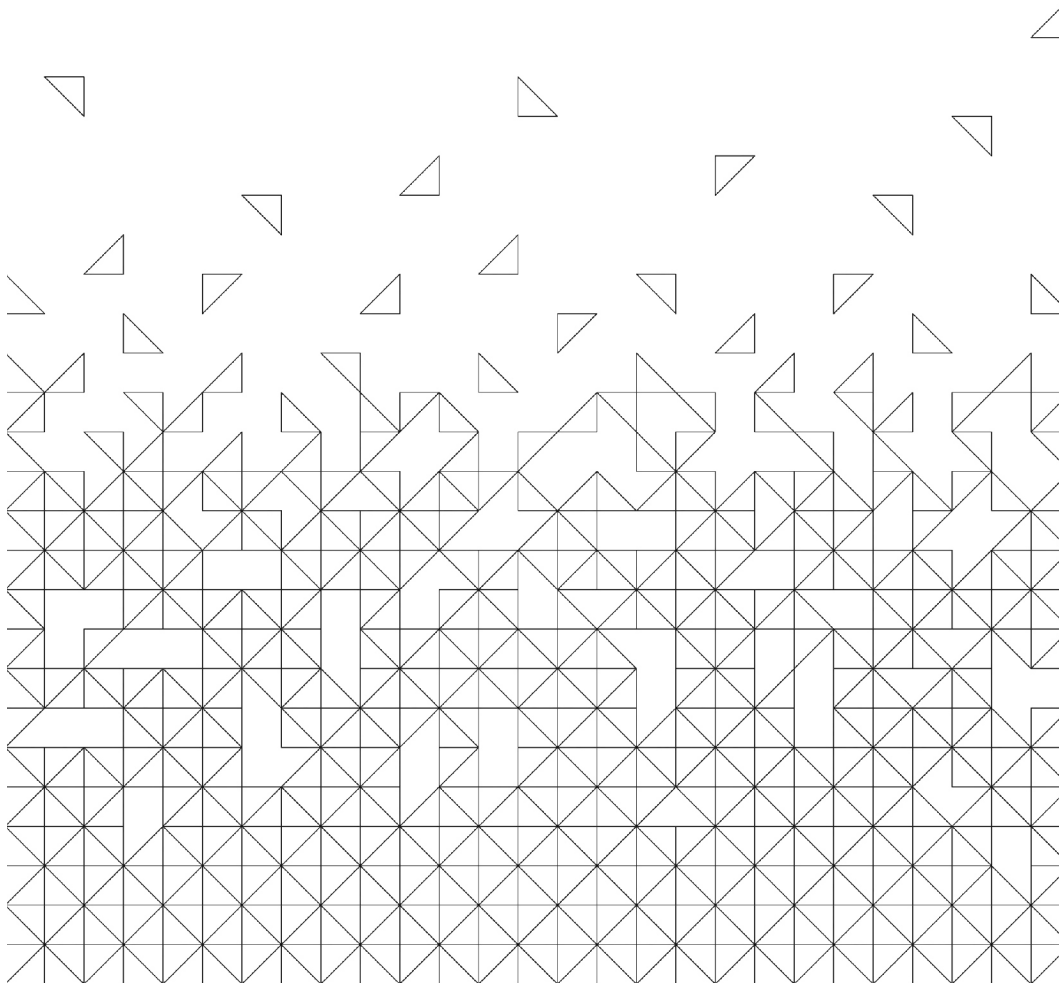

Product support

Help is always at hand

Troubleshooting

If you have a problem with your product, these questions may be able to assist you?

Question- Wine cooler does not operate

Answer

Not plugged in.

The circuit breaker tripped or blown fuse.

Question - Wine cooler is not cold enough.

Answer

Check to be sure the temperature control setting.

External environment may require a higher setting.

The door is opened too often.

The door is not closed completely

The door gasket does not seal properly

The wine cooler does not have the correct clearances.

Question - Compressor turns on and off frequently

Answer

The room temperature is hotter than normal.

A large amount of contents has been added to the wine cooler

The door is opened too often. The door is not closed completely

The temperature control is not set correctly

The door gasket does not seal properly

The wine cooler does not have the correct clearances.

Question- The light does not work.

Answer

The home circuit breaker or fuse has tripped.

The wine cooler is unplugged.

The switch is in the "OFF" position.

If the LED light is broken, please contact qualified technician.

Question-Vibrations

Answer

Check to assure that the wine cooler is level.

Question - The wine cooler seems to make too much noise.

Answer

The rattling noise may come from the flow of the refrigerant, which is normal.

As each cycle ends, you may hear gurgling sounds caused by the flow of refrigerant in your wine cooler

Contraction and expansion of the inside walls may cause popping and crackling noises.

The wine cooler is not level.

Question - The door will not close properly

Answers

The wine cooler is not level.

The doors were reversed and not properly installed.

The gasket is dirty

The shelves are out of position.

Product support

Help is always at hand

Help and assistance

If you require any technical guidance or find that your refrigerator is not operating as intended, a simple solution can often be found in the **Troubleshooting** section of these instruction or online at www.argos-support.co.uk

If you still require further assistance, call one of our experts on **0345 257 7271**. To help give us give you a fast and efficient service please have the following information ready.

Model Ref.

You can find these on the rating plate-a small information panel (usually a sticker or metal plate) on the rear of your appliance

Serial number

Date of purchase

This will be shown on your receipt

Local call rates applies*

Line open 8am-7pm Monday to Saturday and 10am-4pm Sunday

*Calls to Argos enquiry lines may attract a charge and set up fee from residential lines depending on your call plan/tariff. Mobile and other providers costs may vary, see www.bt.com/pricing for details.

For security and training purpose, telephone calls to and from customer service centres maybe recorded and monitored. Call from Republic of Ireland will attract international call charges.

CE This appliance complies with the following EEC directives:
2014/35/EEC Low voltage directive
2014/30/EU EMC directive

Product support

Help is always at hand

BUSH

Call us now and activate your 12 month guarantee

Thank you for choosing Bush. Your new product is guaranteed against faults and breakdowns for 12 months. Don't forget to register it with us today so we can provide you with our best possible after-sale service and useful updates.

www.bushregistration.co.uk

FREEPHONE*

0800 597 8548

Lines are open 8am-8pm, 365 days a year. *Call may be recorded and monitored.

Your Bush Guarantee

This product is guaranteed for twelve months from the date of original purchase. Any defect that arises due to faulty materials or workmanship will be repaired free of charge (or if applicable the product will be replaced or the purchase price refunded) where possible during this period by the dealer from whom your purchased unit.

The guarantee is subject to the following provisions:

- The guarantee does not cover accidental damage, misuse cabinet parts, knobs or consumable items.
- The product must be correctly installed and operated in accordance with the instructions contained in the manual
- It must be used solely for domestic purposes. The guarantee will be rendered invalid if the product is re-sold or has been damaged by inexpert repair.
- Specifications are subject to change without notice.
- Bush disclaim any liability for loss or damage arising from the breakdown of the product
- This guarantee is in addition to and does not diminish your statutory or legal rights

Important Data Protection Information

If you provide us with information about another person, you confirm that they have appointed you to act for them, to consent to the processing of their personal data including sensitive personal data and that you have informed them of our identity and the purpose (as set out in the important Data Privacy notice displayed overleaf) for which their personal data will be processed

You are entitled to ask for a copy of the information we hold about you (for which we may charge a small fee) and to have

any inaccuracies in your information corrected

For quality control and training purposes, we may monitor or record your communications with us.

If your personal details change, if you change your mind about any of your marketing preferences or if you have any queries about how we use your information, please let us know by contacting our Data Protection Officer, Domestic & General, Leicester House 17 Leicester Street, Bedworth, Warwickshire CV128JP

BUSH

Contact

www.argos-support.co.uk

Helpline: 0345 257 7271

CKBSH-A03