

# Hygena Insert Undersink Storage

**Assembly Instructions** – Please keep for future reference

833/6642

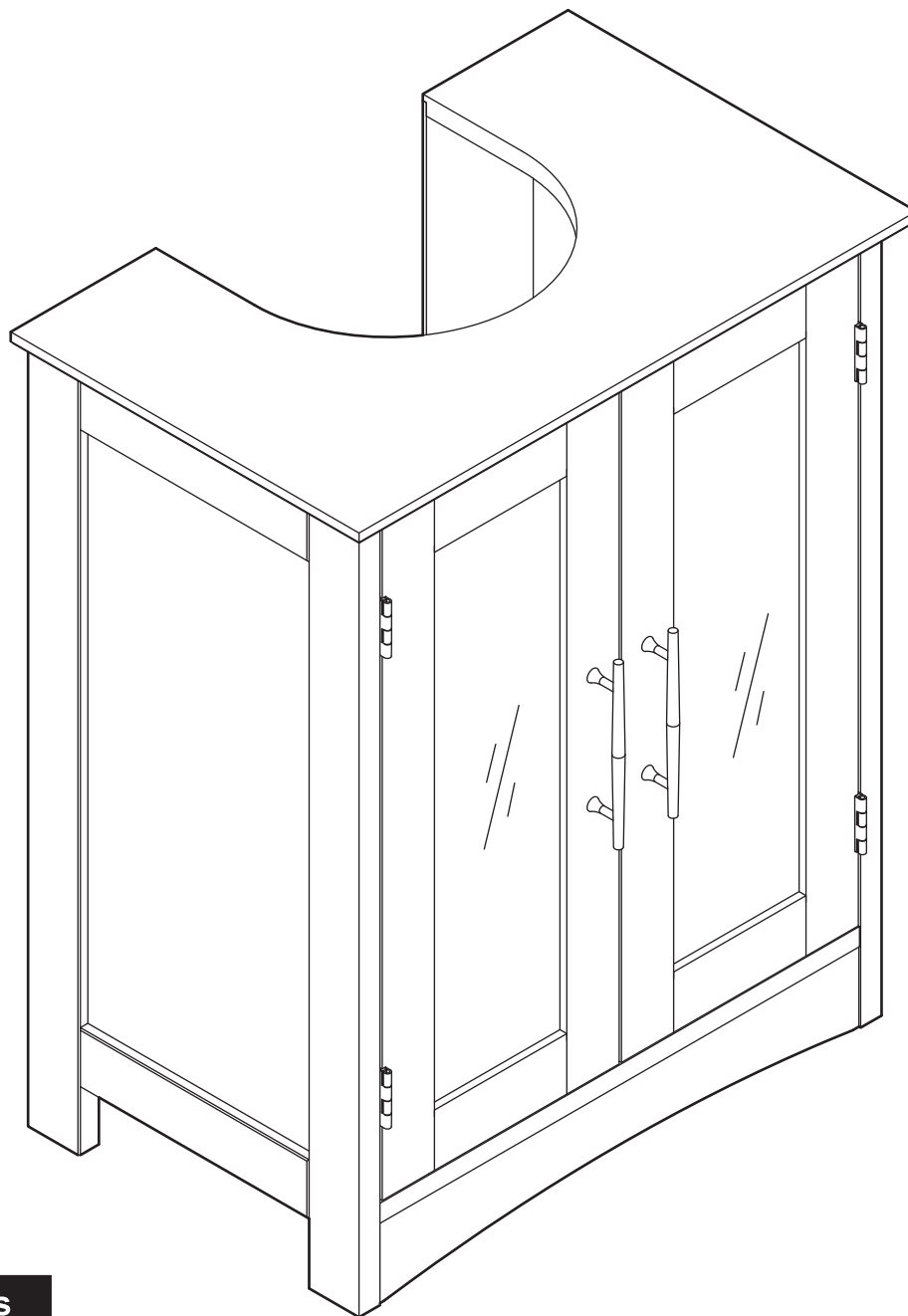

## Dimensions

Width - 48cm

Depth - 30cm

Height - 60cm

**Important** - Please read these instructions fully before starting assembly

If you need help or have damaged or missing parts, call the Customer Helpline: 08456 400800



# Safety and care advice

**Important - Please read these instructions fully before starting assembly**

- Check you have all the components and tools listed on pages 2 and 3.
- Remove all fittings from the plastic bags and separate them into their groups.
- Keep children and animals away from the work area, small parts could choke if swallowed.
- Make sure you have enough space to layout the parts before starting.
- Do not stand or put weight on the panels, this could cause damage.
- Assemble the unit as close to its final position (in the same room) as possible.

- Assemble on a soft level surface to avoid damaging the unit or your floor.
- **Note:** Only apply the glue once you are sure of the assembly.
- The wall plugs supplied are suitable for solid walls only. It is important that the correct type of fixing is used for your wall, seek professional advice if in doubt.
- Parts of the assembly will be easier with 2 people.
- If using power tools, please follow the safety instructions supplied with the tools.



- We do not recommend the use of power drill/ drivers for inserting screws, as this could damage the unit. Only use hand screwdrivers.

- **Warning:** Before drilling, check the wall for hidden pipes and cables.
- Dispose of all packaging carefully and responsibly.

**Glue safety - Take care when using glue, please follow the advice below**

**Skin contact:** Remove contamination by washing with soap and water. This procedure should also be followed prior to eating and drinking.

**Eye contact:** Rinse immediately with clean water for 15 minutes and seek medical advice.

**If swallowed:** Seek medical advice immediately. If possible show product information or label to the medical advisor.

## Care and maintenance

- Only clean using a damp cloth and mild detergent, do not use bleach or abrasive cleaners.
- From time to time check that there are no loose screws on this unit.
- This product should not be discarded with household waste. Take to your local authority waste disposal centre.

**Note:** if required the next page can be cut out and used as a reference throughout the assembly. Keep this page with these instructions for future reference.

# Components - Panels

If you have damaged or missing components,  
call the Customer Helpline:08456 400800

Please check you have all the panels listed below

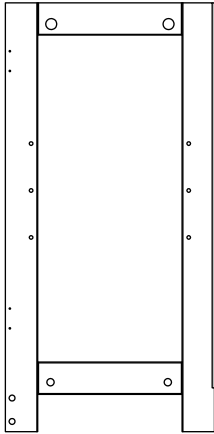

1 Left side Panel

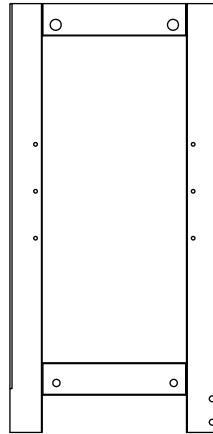

2 Right side Panel

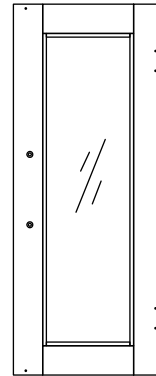

3 Door Panel x 2

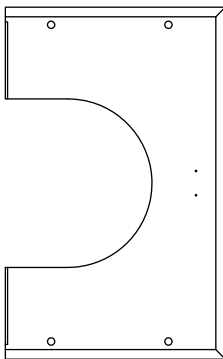

4 Top Panel

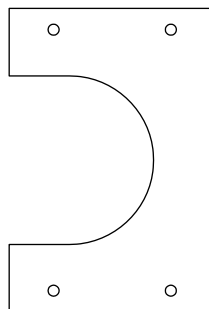

5 Bottom Panel

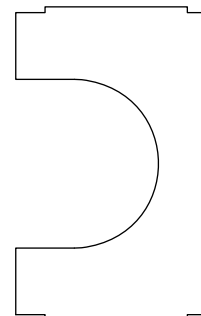

6 Adjustable shelf



7 Back Panel x 2









8 Rail

# Components - Fittings

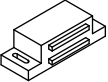
Please check you have all the fittings listed below

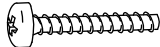
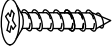
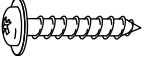
Note: The quantities below are the correct amount to complete the assembly. In some cases more fittings may be supplied than are required.

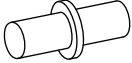
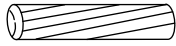
<p><b>A</b> </p> <p>Locking Pin x 8</p>	<p><b>B</b> </p> <p>Locking Nut x 8</p>	<p><b>C</b> </p> <p>Hinge x 4</p>
<p><b>D</b> </p> <p>Magnetic Catch x 1</p>	<p><b>E</b> </p> <p>Strike Plate x 2</p>	<p><b>F</b> </p> <p>18mm Bolt x 4</p>
<p><b>G</b> </p> <p>12mm Screw x 20</p>	<p><b>H</b> </p> <p>12mm Screw x 10</p>	<p><b>I</b> </p> <p>Metal handle x 2</p>
<p><b>J</b> </p> <p>Metal Support x 4</p>	<p><b>K</b> </p> <p>Wooden dowel x 4</p>	

## Tools required

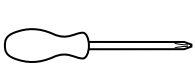

Phillips screwdriver  
(medium & large)

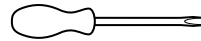

Flatblade screwdriver  
(medium)

Ruler - Use this ruler to help correctly identify the screws

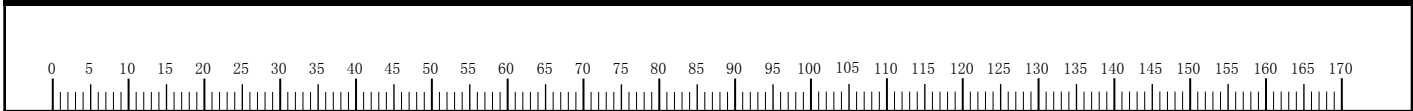

# Assembly Instructions

## Step 1

### Assembling bottom panel

NOTE: It would be useful to ask someone to help you at this stage.

Insert locking pins **A** and wooden dowels **K** into left side panel **1** and right side panel **2**.

Insert locking nut **B** into bottom panel **5** and attach left side panel to right side panel with bottom panel and rail **8** in the middle.

Tighten the locking nut to secure the unit.

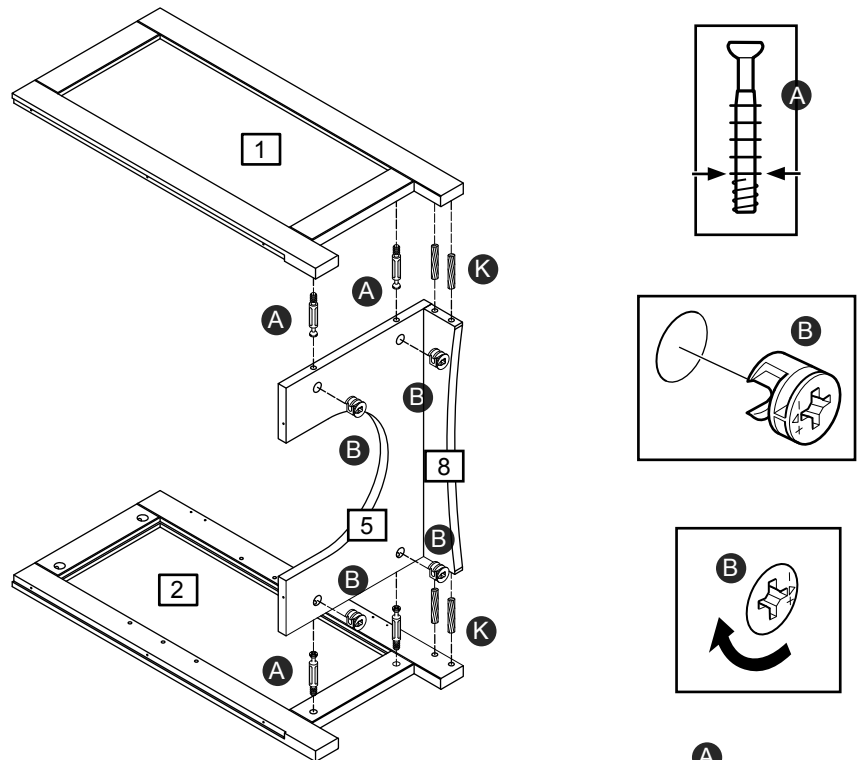

## Step 2

### Assembling top panel

a: Screw locking pins **A** into top panel **4**.

Use 12mm screws **G** to fix magnetic catch **D** onto the top panel.

b: Insert locking nut **B** into left side panel **1** and right side panel **2**.

Attach top panel onto the unit.

Tighten the locking nut to secure the unit.

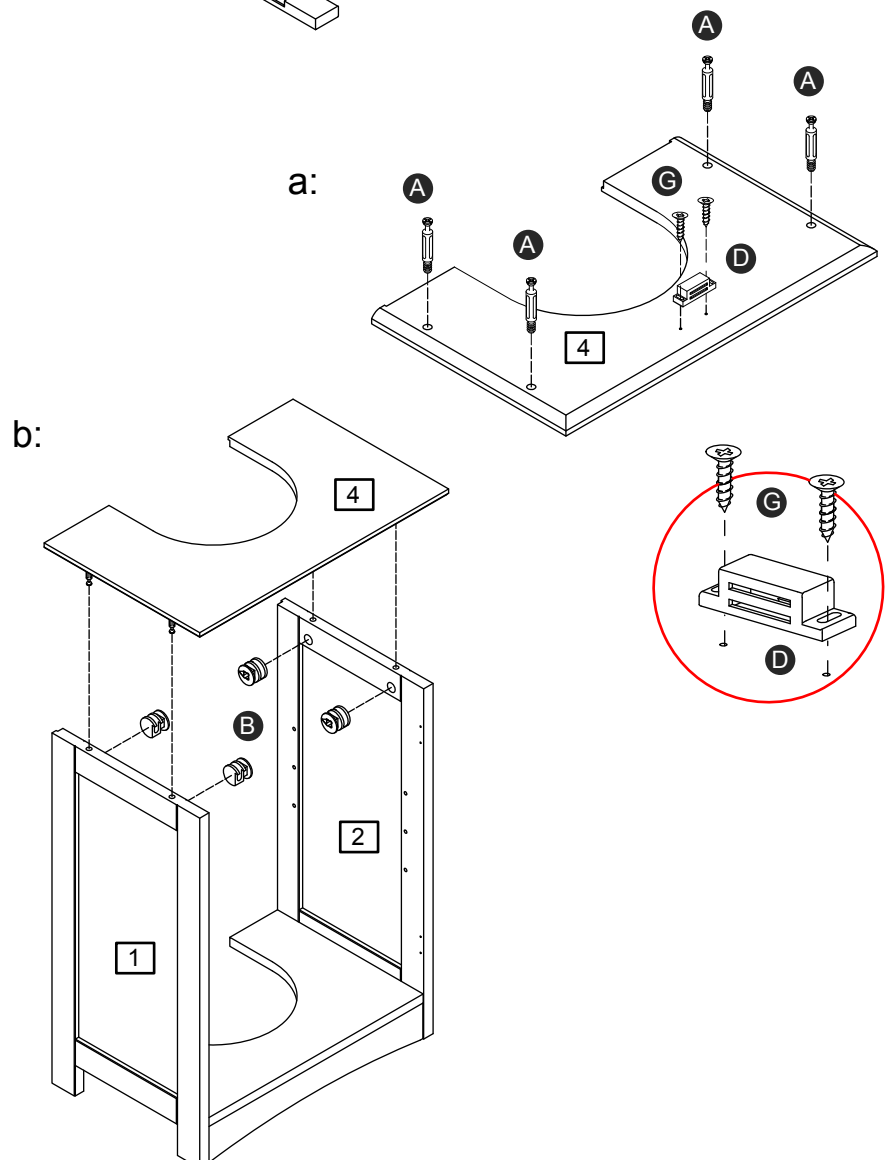

# Assembly Instructions

## Step 3

### Assembling back panel

Use 12mm screws **H** to fix back panels **7** onto the unit.

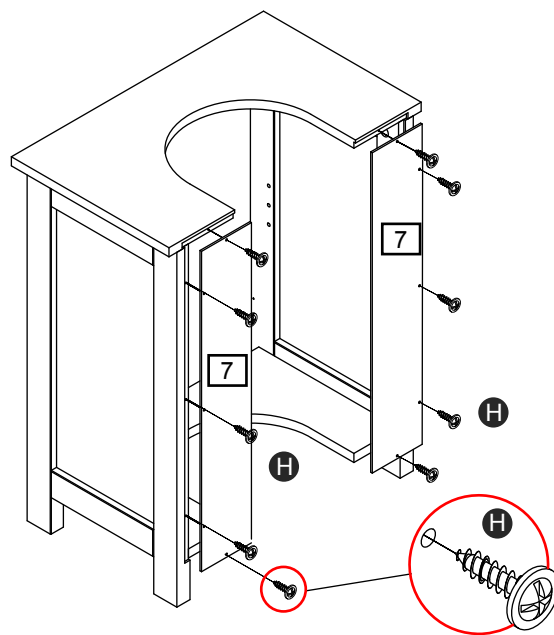

## Step 4

### Assembling door panel

NOTE: It would be useful to ask someone to help you at this stage.

a: Use 12mm screws **G** to fix hinges **C** onto the door panel **3**.

Use 18mm bolts **F** to fix metal handle **I** onto door panel.

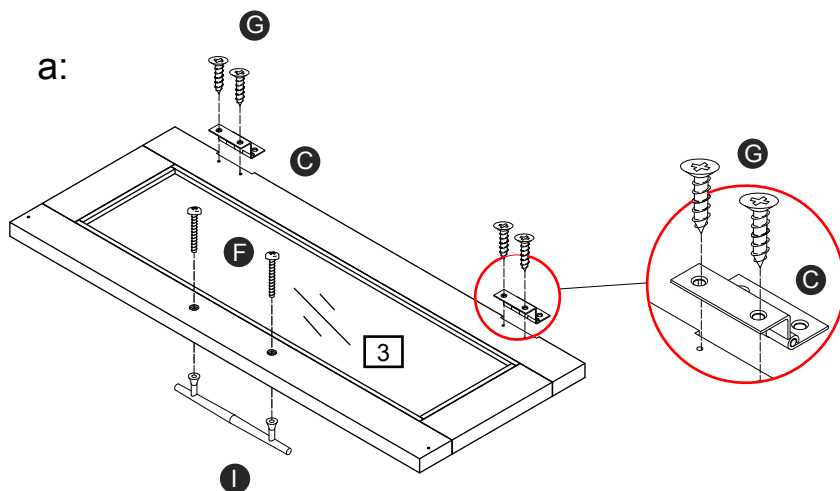

b: Attach door panels **3** onto the unit by fixing hinge **C** with screw **G**.

Use 12mm screw **G** to fix strike plate **E** onto the door panel **3**.

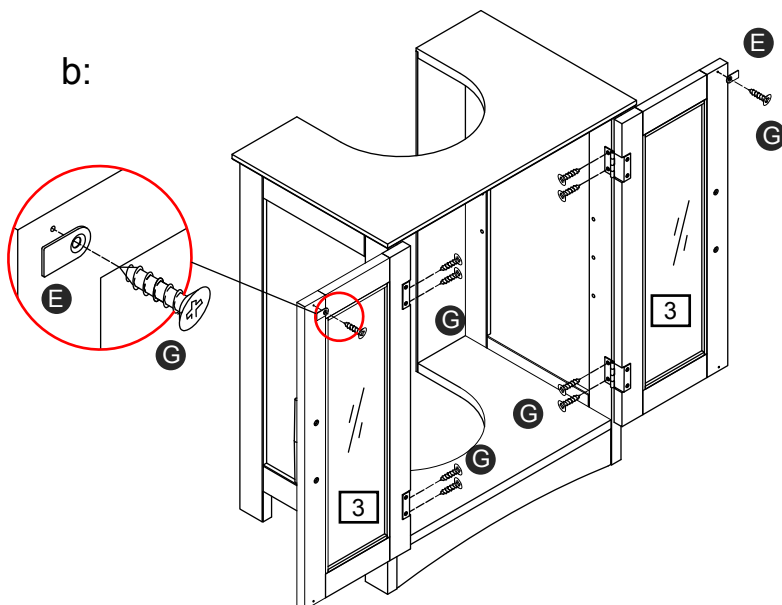

# Assembly Instructions

## Step 5

### Assembling adjustable shelf panel

NOTE: It would be useful to ask someone to help you at this stage.

Insert metal supports **J** into left and right side panels.

Carefully put the adjustable shelf panel **6** on it.

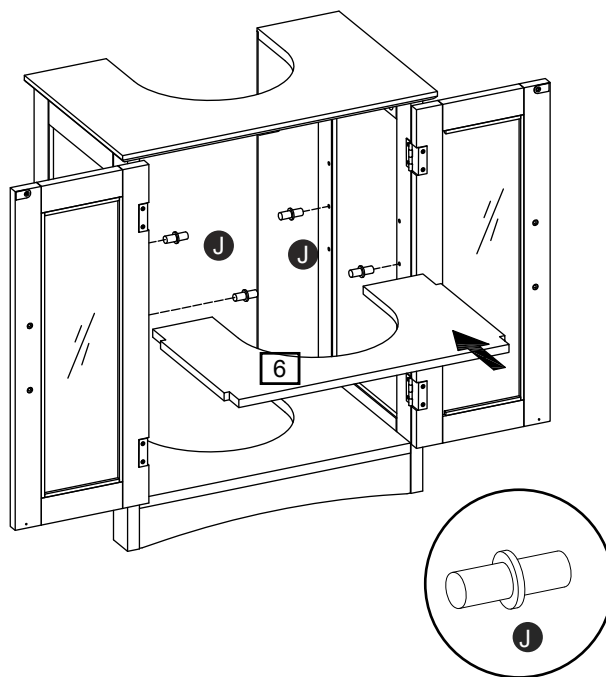

NOTE: Please make sure the unit is secure before use.

The assembly is now complete.

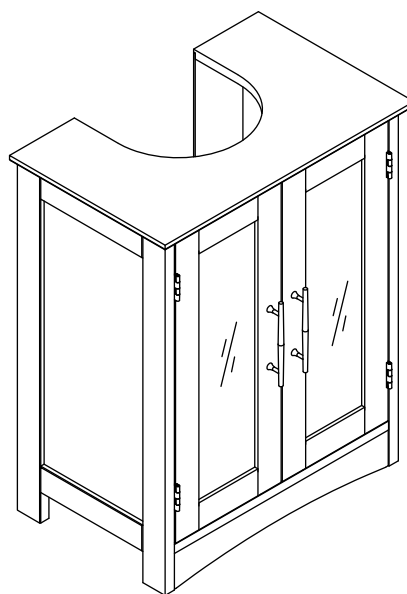

NOTE: If you have damaged or missing components, call the Customer Helpline: 08456 400800  
Argos LTD, 489-499 Avebury Boulevard,  
Central Milton Keynes, MK9 2NW

## SAFETY WARNING INFORMATION

Keep these instructions for future use:

### WARNINGS

\*Do not place very hot or very cold items against or in close proximity to glass surface unless an adequately thick insulating material is used to prevent such items from coming into contact with the glass.

\*Do not strike the glass with hard or pointed items.

\* Do not sit or stand upon horizontal glass surfaces.

\*When cleaning glass panels or mirrors use a damp or leather with washing up liquid or soft soap if necessary do not use washing powders or any other substance containing abrasive since these substances scratch glass.

\*It is essential that this unit is fixed to a wall with the fixings provided.

## BS7449 : 1991

Catalogue Number: 833/6642 (D)

Manufacture date: Apr. 17th. 2013

Retailer: Argos

Retailer address: 489-499 Avebury Boulevard  
Saxon Gate West  
Central Milton Keynes  
Bucks, MK9 2NW

This unit contains [tempered glass](#) of a nominal thickness of 4 mm, which is not required to be classified to BS6206 Class C.

If a glass is chipped or broken replace with glass of the type described on this label. Consult the manufacturer, retailer, or agent with regard to obtaining a manufacturing specification and shape for replacement glass quoting the model number, and batch number or date of manufacture.