

Turn on the water supply and check connection for leaks.

If the electric supply is on the right hand side then you will need to move the terminal block. Otherwise proceed with Step 6.

Unscrew the terminal block retaining screw.

Carefully lift the terminal block from its location on the left of the case and move it to the right of the case, taking care not to damage the wires.

Refit the retaining screw.

Strip back sufficient outer cable insulation to enable routing to terminal block.

Fit an earth sleeve to the earth wire.

Loosen the screws in the terminal block and insert the wires.

L (Live) = Brown wire
⊕ (Protective Earth) = Green /Yellow sleeved wire
N (Neutral) = Blue wire

Tighten the screws in the terminal block, ensure the wires are secure and tight.

Ensure the earth bonding complies with relevant regulations.

Replace the service tunnel.

Ensure the control dials are aligned with the spindles and replace the cover.

Tighten the four cover screws.

Do not use alternative screws to secure the cover. This can cause internal damage to the appliance.

Do not seal around the back of appliance.

COMMISSIONING

1 Turn temperature control to the cold position.

2 Turn power control to low.

3 Switch on the electrical supply.

0 - 15 secs

4 Push START/STOP button.

5 Water flows freely within a few seconds, temperature remains cool.

6 Turn power control to Eco.

7 Temperature will rise slightly.

8 Turn power control to High.

9 Temperature will rise further.

10 Adjust temperature as required. Flow rate will adjust automatically.

11 Push START/STOP button.

12 The shower will purge water from its tank for a few seconds.

0 - 5 secs

13 Switch off the electrical supply.

FAULT DIAGNOSIS

Warning! There are no user serviceable components beneath the cover of the appliance. In the event of a malfunction of the shower, the troubleshooting information below provides details on possible causes and remedies that may be carried out by qualified, competent personnel. Non-qualified personnel should refer to the fault diagnosis section in the users guide.

Symptom	Possible Cause	Possible Remedy
No hot water from the shower, with the controls in any position.	Insufficient water supply pressure.	Contact local water authority.
	Failure of the pressure switch, microswitch or thermal switch.	Check the continuity of the switches, using a suitable continuity measuring device. Replace the switches as necessary.
The shower temperature cycles between hot and cold.	An internal wiring connection has failed.	Check the integrity of the internal wiring.
	One of the heater tank elements has failed.	Replace the heater tank.
Turning the temperature control does not affect the water temperature.	Switch assembly diaphragm fault, water dripping from the unit.	Replace switch assembly.
	The temperature is set too high. This is causing the thermal switch to turn off the heating element to reduce the water temperature.	Turn the temperature control anticlockwise to reduce the water temperature. DO NOT TAMPER with the thermal switch.
The shower temperature cycles between hot and cold.	The flow regulator is faulty.	Replace the flow regulator.
	The handset sprayplate is blocked.	Remove and clean the handset sprayplate. Refer to the shower fittings User Guide. If the fault persists, contact Customer Services.
Turning the temperature control does not affect the water temperature.	The flow regulator is faulty.	Replace the flow regulator.
	The handset sprayplate is blocked.	Remove and clean the handset sprayplate. Refer to the shower fittings User Guide. If the fault persists, contact Customer Services.
Water leaks from the bottom of the case near the outlet and there is no flow from the handset.	The pressure relief valve in the tank has been triggered (the shower has a pressure relief valve assembly that works to reduce the damage if the outlet is blocked or the unit is frozen), when the relief valve operates a small rubber ball is ejected.	Resolve the blocked outlet and replace the tank assembly.
	The pilot valve is faulty.	Replace the flow regulator assembly.
The water cannot be turned off.	Broken diaphragm.	Replace the flow regulator assembly.
	The supply pressure is below the minimum requirement.	Contact local water authority. Check the static water pressure. Note that the static water pressure may fall below the minimum requirement when other appliances are drawing water, for example the dishwasher or the washing machine.
No water or very low flow rate.	The handset sprayplate is blocked.	Regularly clean the handset sprayplate.
	The hose or handset is blocked.	Clear the blockage or replace the hose or handset.
The incoming water supply stop valves, or the appliance isolating valve is closed.	Insufficient water supply pressure.	Contact the local water authority.
	The heater tank is excessively scaled.	Replace the heater tank.
The pilot valve is faulty.	Replace the flow regulator assembly.	Replace the flow regulator assembly.
	The inlet filter is blocked.	Clean the inlet filter.

SERVICING

Symptom	Possible Cause	Possible Remedy
No water or very low flow rate.	The power does not turn on at the double pole switch. The fuse is blown or the MCB/RCD has been tripped, indicating a possible electrical fault; for example, heater tank element failure.	Clean the inlet filter. Switch on the power at the double pole switch.
The shower temperature cycles between hot and cold.	The temperature is set too high. This is causing the thermal switch to turn off the heating element to reduce the water temperature.	Turn the temperature control anticlockwise to reduce the water temperature. DO NOT TAMPER with the thermal switch.
Turning the temperature control does not affect the water temperature.	The flow regulator is faulty. The handset sprayplate is blocked.	Replace the flow regulator. Remove and clean the handset sprayplate. Refer to the shower fittings User Guide. If the fault persists, contact Customer Services.
Water leaks from the bottom of the case near the outlet and there is no flow from the handset.	The pressure relief valve in the tank has been triggered (the shower has a pressure relief valve assembly that works to reduce the damage if the outlet is blocked or the unit is frozen), when the relief valve operates a small rubber ball is ejected.	Resolve the blocked outlet and replace the tank assembly.
The water cannot be turned off.	The pilot valve is faulty.	Replace the flow regulator assembly.
	Broken diaphragm.	Replace the flow regulator assembly.
The supply pressure is below the minimum requirement.	The supply pressure is below the minimum requirement.	Contact local water authority. Check the static water pressure. Note that the static water pressure may fall below the minimum requirement when other appliances are drawing water, for example the dishwasher or the washing machine.

CUSTOMER SERVICE

WARNING
 There are no user serviceable parts inside the shower.

Servicing of the shower must only be carried out by qualified, competent personnel following the instructions provided in this guide and those provided with any spare part.

Before replacing any parts, ensure that the underlying cause of the malfunction has been resolved.

Cleaning the Inlet Filter

Warning! Isolate the electrical and water supplies before removing the cover.
 Remove the cover and the service tunnel.
 Use a suitable spanner to remove the filter from the inlet connector assembly. Hold a wrench across the flats of the inlet connector assembly to prevent damage to the connector, whilst removing the filter.
 Remove the filter and rinse under a running tap to remove any lodged particles. If necessary, use a kettle descaler in accordance with the manufacturer's instructions.
 Refit the components in reverse order.

SPARE PARTS

- 1789.080 Service Insert Pack
- 439.76 Clamp Bracket Pack
- 1789.085 Switching Assembly
- 439.75 Inlet Connector
- 439.27 Inlet Filter
- 439.77 (8.5 kW) / 1539.350 (9.5/10.8 kW) Flow Valve Assy
- 1789.084 Terminal Block Assy
- 1789.076 Mira Shore Cover Assy
- 1789.077 Mira Isle Cover Assy
- 439.90 Thermal Switch
- 1789.079 Service Tunnel
- 1798.054 (8.5 kW) / 1798.055 (9.5 kW) / 1798.056 (10.8 kW) Heater Tank Assy
- 1789.081 Wire Pack (Not illustrated)
- 1789.082 Screw Pack (Not illustrated)
- 1789.083 Cover Seal (Not illustrated)
- 439.88 Seal Pack (Not illustrated)
- 1789.085 Latching Switch

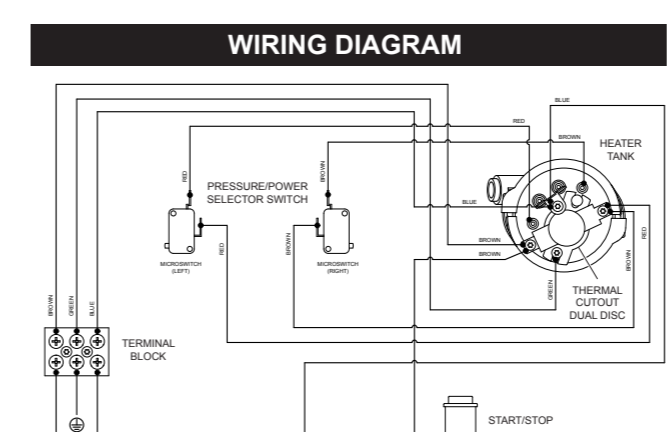

CUSTOMER SERVICE

Guarantee
 Your product has the benefit of our manufacturer's guarantee which starts from the date of purchase. To activate this guarantee, please return your completed registration card, visit our website or free phone 0800 0731248 within 30 days of purchase (UK only).
 Within the guarantee period we will resolve defects in materials or workmanship, free of charge, by repairing or replacing parts or product as we may choose.
This guarantee is in addition to your statutory rights and is subject to the following conditions:

- The guarantee applies solely to the original installation under normal use and to the original purchaser only. The product must be installed and maintained in accordance with the instructions given in this user guide.
- Servicing must only be undertaken by us or our appointed representative. **Note!** If a service visit is required the product must be fully installed and connected to services.
- Repair under this guarantee does not extend the original expiry date. The guarantee on any replacement parts or product ends at the original expiry date.
- For shower fittings or consumable items we reserve the right to supply replacement parts only.

The guarantee does not cover:

- Call out charges for non product faults (such as damage or performance issues arising from incorrect installation, improper use, inappropriate cleaning, lack of maintenance, build up of limescale, frost damage, corrosion, system debris or blocked filters) or where no fault has been found with the product.
- Water or electrical supply, waste and isolation issues.
- Compensation for loss of use of the product or consequential loss of any kind.
- Damage or defects caused if the product is repaired or modified by persons not authorised by us or our appointed representative.
- Routine maintenance or replacement parts to comply with the requirements of the TMV 2 or TMV 3 healthcare schemes.
- Accidental or wilful damage.
- Products purchased ex-showroom display.

What to do if something goes wrong
 If your product does not work correctly refer to this manual for fault diagnosis and check that it is installed and commissioned in accordance with our instructions.
 If this does not resolve the issue, contact us for help and advice.

Extended Guarantees
 A selection of protection plans are available that enable you to cover repair bills (excludes Eire). Ring 01922 471763 for more details.

Helpdesk Service - Ring our Customer Services Team for product advice, to purchase spare parts or accessories or to set up service visit. You can contact us via phone or e-mail, details below. Please provide your model name, power rating (if applicable) and date of purchase.

Mira Showers Website (www.mirashowers.co.uk)
 Visit our website to register your guarantee, download user guides, diagnose faults, purchase our full range of accessories and popular spares, or request a service visit.

Spares and Accessories - We hold the largest stocks of genuine Mira spares and accessories. Contact us for a price or visit our website to purchase items from our accessory range and popular spares.

Service/Repairs - No one knows our products better than our nationwide team of Service Technicians. We can carry out service or repair work to your product both during and after the guarantee period. Ask about our fixed price service repairs.

To Contact Us

0844 571 5000

Fax: 01 242 282595

E-mail: Visit www.mirashowers.co.uk/contactus

Mira Customer Services
 Dept, Cromwell Road, Cheltenham, Gloucestershire, GL52 5EP

To Contact Us: Eire Only

01 531 9337

E-mail: CustomerServiceEire@mirashowers.com

Mira Shore

8.5, 9.5 and 10.8 kW Electric Shower

Mira Isle

8.5, 9.5 and 10.8 kW Electric Shower

These instructions must be left with the user

Installation Guide

Showering perfection

8 Install the shower fittings (Refer to the Shower Fittings Installation and User Guide packed with the product).

9 This completes the installation.

Mira is a registered trade mark of Kohler Mira Limited.

The company reserves the right to alter product specifications without notice.

© Kohler Mira Limited, May 2013

For SPARES, ADVICE or REPAIRS

Please call us on **0844 571 5000** (UK Only)

INTRODUCTION

Thank you for purchasing a quality Mira Electric Shower. To enjoy the full potential of your new shower, please take time to read this guide thoroughly, and keep it handy for future reference.

Products manufactured by Kohler Mira Ltd are designed to be safe provided, that they are installed used and maintained in good working order, in accordance with our instructions and recommendations.

Follow all warnings, cautions and instructions contained in this guide, and on or inside the shower.

This product has separate controls for power selection and for temperature/flow adjustment. A unique flow regulator stabilises any temperature changes caused by water pressure fluctuations, which can result from taps being turned on or off or toilets being flushed.

When this shower has reached the end of its serviceable life, it should be disposed of in a safe manner, in accordance with current local authority recycling, or waste disposal policy.

Mira Electric Showers covered by this guide:

Product	Model Number	Colour
Mira Shore 8.5, 9.5 & 10.8 kW	J02 Ab	White
	J02 Ac	
	J02 Ad	
Mira Isle 8.5, 9.5 & 10.8 kW	J02 Bc	White
	J02 Bd	
	J02 Be	

Guarantee

This product has been designed for domestic use only, Mira Showers guarantee this product against any defect in materials or workmanship for a period of two years from the date of purchase (shower fittings for one year).

For terms and conditions, refer to the back cover of this guide.

Patents and Design Registration

Design Registration:	001327852-0001-0003
Patents:	GB 2 427 460 Ireland 85912

IMPORTANT SAFETY INFORMATION

WARNING - This shower can deliver scalding temperatures if not operated, installed or maintained in accordance with the instructions, warnings and cautions contained in this guide and on or inside the appliance.

TO REDUCE THE RISK OF FIRE, ELECTRIC SHOCK OR INJURY:

- Installation of this shower must be carried out in accordance with these instructions by qualified, competent personnel.
- Isolate the electrical and water supplies before commencing installation. The electricity must be isolated at the consumer unit and the appropriate circuit fuse removed, if applicable. Mains connections are exposed when the cover is removed.
- DO NOT** install the shower in areas with high humidity and temperature (i.e. steam rooms and saunas).
- DO NOT** install the shower where it may be exposed to freezing conditions. Ensure that any pipework that could become frozen is properly insulated.
- DO NOT** switch the shower on if there is a possibility that the water in the shower is frozen.
- DO NOT** switch the shower on if water starts leaking from the shower case. Isolate the electrical supply to the shower immediately.
- DO NOT** connect the outlet of the shower to any tap, control valve, trigger handset or showerhead other than those specified for use with this shower. Only Kohler Mira recommended accessories should be used.
- The water supplies to this product must be isolated if the product is not to be used for a long period of time. If the product or pipework is at risk of freezing during this period they should also be drained of water.
- DO NOT** perform any unspecified modifications to the shower or its accessories. When servicing only use genuine Kohler Mira replacement parts.

- If the shower is dismantled during installation or servicing then upon completion the product must be inspected to ensure all electrical connections are tight and that there are no leaks.

- Read all installation instructions before installing this shower.

- Upon completion of the installation, make sure that the user is familiar with the operation of the shower, and leave this guide and the user guide with the owner.

PACK CONTENTS

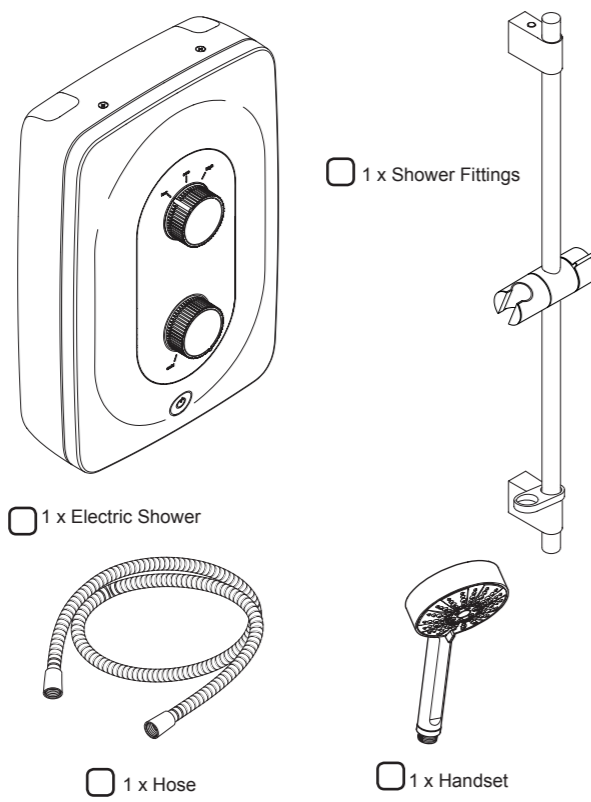

Documentation

- 1 x Installation Guide
- 1 x User Guide
- 1 x Guarantee Brochure

SPECIFICATION

Plumbing	Variant		
	8.5	9.5	10.8
Minimum Dynamic Pressure	70 kPa (0.7 bar)	70 kPa (0.7 bar)	100 kPa (1.0 bar)
Maximum Dynamic Pressure	500 kPa (5.0 bar)		
Maximum Static Pressure	1000 kPa (10 bar)		
Minimum Static Pressure	50 kPa (0.5 bar)		
Maximum Inlet Temperature	30°C		
Minimum Inlet Temperature	2°C		
Inlet Connection	15 mm compression/Pushfit Coupling		
Maximum Water Hardness	200 ppm CaCO ₃		
Outlet Connection	1/2" BSP Male		

Electrical	Variant		
	8.5	9.5	10.8
Nominal Power at 240 V ac	8.5 kW	9.5 kW	10.8 kW
Nominal Power at 230 V ac	7.8 kW	8.7 kW	9.9 kW
Recommended MCB Rating	40 A	40A	45 A
Maximum Supply Cable Size	16 mm ²		
Recommended RCD Rating	30 mA tripping current		
Recommended Isolator Switch	45 A double-pole with 3 mm contact separation		
Appliance Sealing Rating	IP X4 - Suitable for installation in Zone 1		
Maximum Ambient Temperature	30°C		
Minimum Ambient Temperature	2°C		

Dimensions	
Height	333 mm
Width	223 mm
Depth	106 mm

European Conformity Information

This range of electric showers complies with the following European directives:

2006/95/EC Low Voltage Directive, 2004/108/EC EMC Directive.

This range of electric showers are high power appliances and are subject to conditional connection. If the main electrical supply fuse is rated less than 80 Amps, the local electricity supply company must be contacted to confirm if the electrical supply is adequate.

This range of showers complies with the requirements of the UK's water regulations.

INSTALLATION REQUIREMENTS

Please read the Important Safety Information and specifications sections at the front of this guide, and the requirements detailed in this section before installing the shower.

WARNING - TO REDUCE THE RISK OF FIRE, ELECTRIC SHOCK OR INJURY.

Plumbing

- The plumbing installation must comply with all national or local water regulations and all relevant building regulations, or any particular regulation or practice specified by the local water supply company.
- Do not install the product in a position in which service access is limited.
- Decide on a suitable position for the shower (minimum distance of 200 mm from the ceiling to allow for cover fit and removal).
- The position of the shower and shower fittings must provide a minimum gap of 25 mm between the showerhead and the spill over level of any bath, shower tray or basin and a minimum gap of 30 mm between the showerhead and the spill over level of any toilet, bidet or other appliance with a Fluid Category 5 backflow risk (see diagram on next page).
- The shower is suitable for installation within the shower area and is fitted with a pressure relief valve. It must be positioned over a water catchment area with the controls at a convenient height for the user.
- The shower must be fitted to a waterproof flat and even wall surface.
- DO NOT** fit the shower to the wall and tile up to the case.
- DO NOT** seal the gap between the shower and the wall surface.
- The showerhead should be positioned so that it discharges down the centre line of the bath or across the opening of a shower cubicle.
- The showerhead must be directed away from the shower unit, during normal use the showerhead must not spray directly on to the shower unit.
- DO NOT** apply excessive force to plumbing connections; always provide mechanical support when making plumbing connections. Any soldered joints should be made before connecting the shower.
- This shower is not designed to be plumbed directly from the rear. For rear-entry supply, add an elbow to the supply pipe and connect as a rising or a falling supply.
- If pipework and/or electrical cables enter the shower from the rear through a hole in the wall provision must be made to prevent water ingress back into the wall structure.
- Only use the inlet connector supplied with the shower. **DO NOT** use any other type of fitting.
- A full bore/non restrictive servicing valve must be fitted in a readily accessible position adjacent to the shower to facilitate maintenance of the shower. **DO NOT** use a valve with a loose washer plate (jumper) as this can lead to a build up of static pressure.
- A water treatment device should be installed where the water hardness may exceed 200 ppm. Malfunctions caused by excessive limescale formation are not covered by this shower's guarantee (see back page for details).
- The installation must not cause the hose to be sharply kinked during normal use.
- DO NOT** perform the electrical installation until the plumbing has been completed and checked for leaks.

- Wall fixings are not supplied. For solid wall structures a red raw plug and a no. 8 x 1½" countersunk brass or stainless steel screw should be used. For other wall structures such as panels alternative fixings may be required. A minimum of 3 fixing screws should be used.

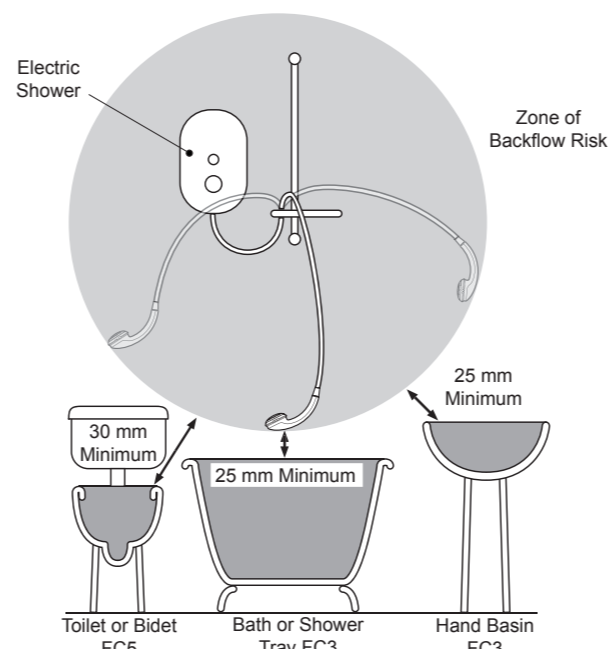

Hose Retaining Ring fitted and shower fittings fixed at a suitable height preventing dirty water backflow.

Note! There will be occasions when the hose retaining ring will not provide a suitable solution for Fluid Category 3 installations, in these instances an outlet double checkvalve must be fitted, this will increase the required supply pressure typically by 10kPa (0.1 bar). Double checkvalves fitted in the inlet supply to the appliance cause a pressure build up, which affect the maximum static inlet pressure for the appliance and must not be fitted. For Fluid category 5 double checkvalves are not suitable.

WARNING - TO REDUCE THE RISK OF FIRE, ELECTRIC SHOCK OR INJURY.

Electrical

- The electrical installation must comply with BS 7671 (commonly referred to as the IEE Wiring Regulations) and all relevant building regulations, or any particular regulation or practice specified by the local electricity supply company.
- Ensure that all circuit protection devices, switches and cabling is adequate for the rated current of the shower and that the rating of the electricity supply company fuse and the consumer unit are adequate for the additional demand.
- The shower **must** be earthed. Ensure any supplementary bonding complies with the relevant regulations.
- This shower is intended to be permanently connected to the fixed electrical wiring of the mains system. A separate supply **must** be provided from the consumer unit to the shower.
- DO NOT** supply any other electrical equipment including extractor fans or pumps via this product.
- This shower must be provided with means for local disconnection that is incorporated into the fixed wiring in accordance with the relevant local wiring regulations. This **must** be a double pole switch, which has at least 3 mm contact separation in each pole. The switch can be a ceiling mounted pull-cord type within the shower room or a wall mounted switch fitted in the applicable zone area.
- A 30mA Residual Current Device (RCD) must be incorporated into the electrical supply to this shower in accordance with wiring regulations.
- DO NOT** apply excessive force to the terminal block.
- All electrical connections should be checked for tightness to prevent overheating before switching on the electrical supply.
- DO NOT** switch on the electrical supply until the plumbing has been completed and checked for leaks.

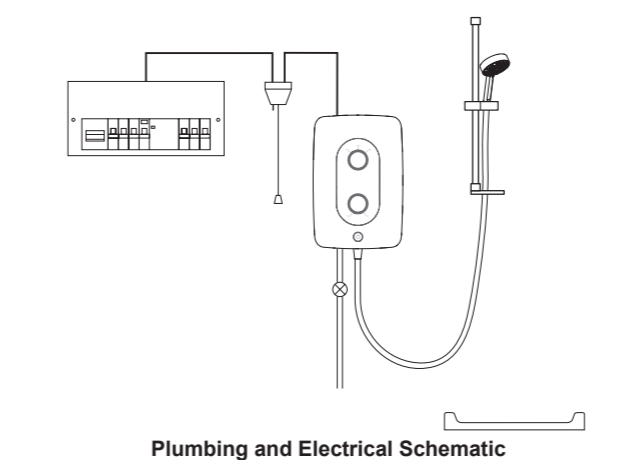

Plumbing and Electrical Schematic

INSTALLATION

New Installation

Warning! Isolate the electrical and water supplies before installing the shower.

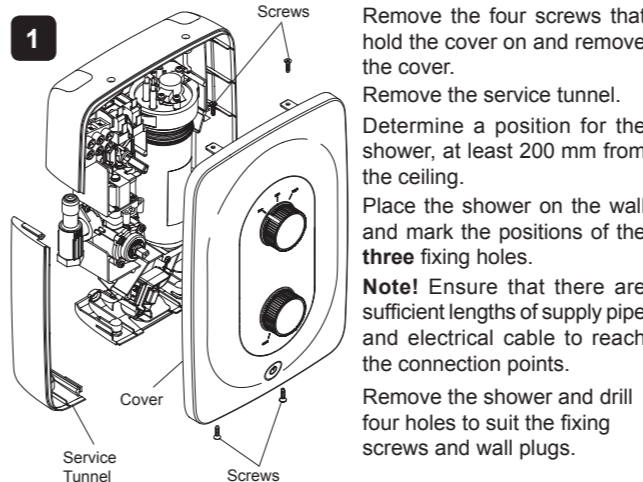

Remove the four screws that hold the cover on and remove the cover.

Remove the service tunnel. Determine a position for the shower, at least 200 mm from the ceiling.

Place the shower on the wall and mark the positions of the three fixing holes.

Note! Ensure that there are sufficient lengths of supply pipe and electrical cable to reach the connection points.

Remove the shower and drill four holes to suit the fixing screws and wall plugs.

Caution! Do not drill into cables or pipes in the wall.

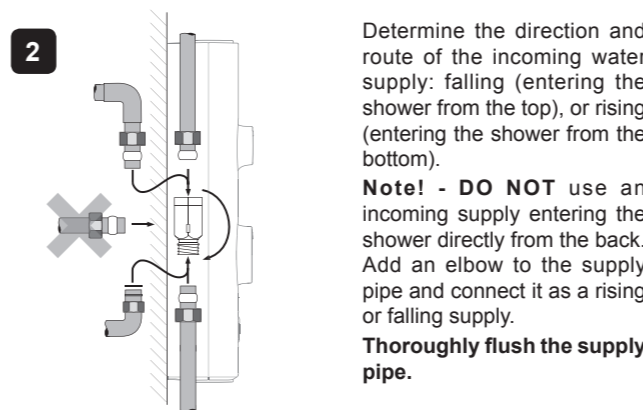

Determine the direction and route of the incoming water supply: falling (entering the shower from the top), or rising (entering the shower from the bottom).

Note! - **DO NOT** use an incoming supply entering the shower directly from the back. Add an elbow to the supply pipe and connect it as a rising or falling supply.

Thoroughly flush the supply pipe.

Rotate the inlet connector to suit the direction of the incoming water supply.

If the water supply enters the shower from the left hand side 'Push Fit' connections can be used for rising or falling pipework.

Upper case inserts are supplied for falling supplies and should be fitted.

For a rising supply cut the thinned section on the service tunnel to suit with a suitable junior hacksaw and file.

Secure the shower to the wall with appropriate wall fixings.

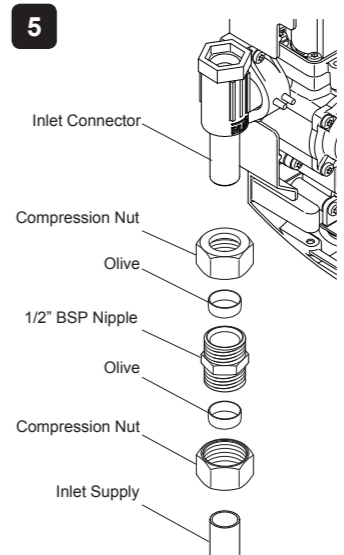

Connect the inlet supply pipe to the inlet connector using a 1/2" BSP nipple with compression nuts and olives (as shown) or a push-fit connector.

Turn on the water supply and check connection for leaks.

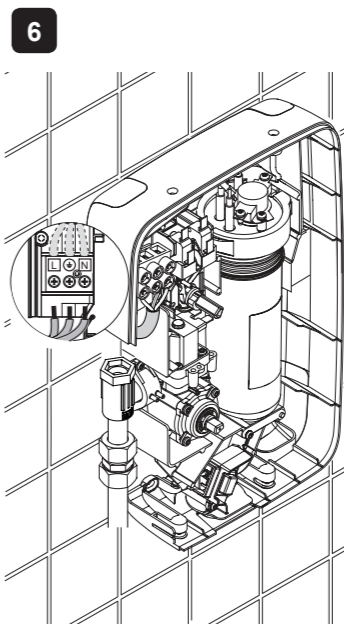

Strip back sufficient outer cable insulation to enable routing to terminal block.

Fit an earth sleeve to the earth wire.

Loosen the screws in the terminal block and insert the wires.

L (Live) = Brown wire

⊕ (Protective Earth) =

Green /Yellow sleeved wire

N (Neutral) = Blue wire

Tighten the screws in the terminal block, ensure the wires are secure and tight.

Ensure the earth bonding complies with relevant regulations.

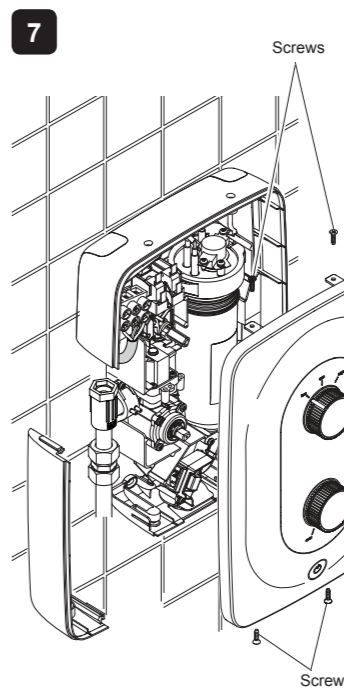

Replace the service tunnel.

Ensure the control dials are aligned with the spindles and replace the cover.

Tighten the four cover screws.

Do not use alternative screws to secure the cover. This can cause internal damage to the appliance.

Do not seal around the back of appliance.

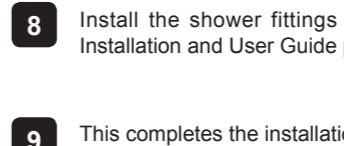

Install the shower fittings (Refer to the Shower Fittings Installation and User Guide packed with the product).



This completes the installation.

Replacing an Electric Shower

This electric shower can replace showers of approximate size and shape.

Terminal Block locations are provided on both the left and right for convenience when replacing a shower.

Note! By default the electrical supply position is set for left hand entry, if the installation favours a right hand entry some adjustment of the terminal block in the case is required.

If the water entry point is on the right hand side of the shower then you will need to alter the incoming pipework as shown below. The thinned sections of the case will also need to be removed to help with the installation. Use a suitable junior hacksaw and file.

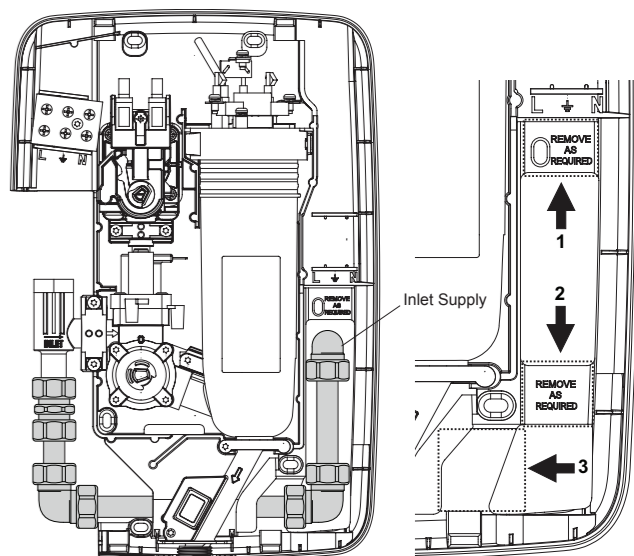

Warning! Isolate the electrical and water supplies before installing the shower.

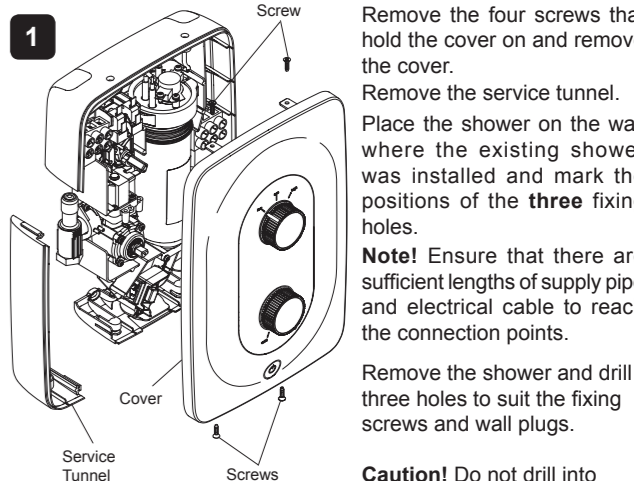

Remove the four screws that hold the cover on and remove the cover.

Remove the service tunnel. Place the shower on the wall where the existing shower was installed and mark the positions of the **three** fixing holes.

Note! Ensure that there are sufficient lengths of supply pipe and electrical cable to reach the connection points.

Remove the shower and drill three holes to suit the fixing screws and wall plugs.

Caution! Do not drill into cables or pipes in the wall.

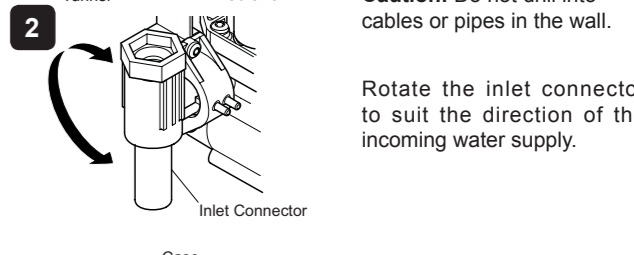

Rotate the inlet connector to suit the direction of the incoming water supply.

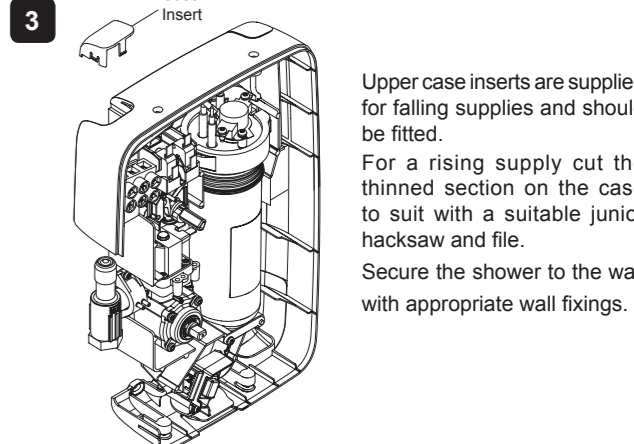

Upper case inserts are supplied for falling supplies and should be fitted.

For a rising supply cut the thinned section on the case to suit with a suitable junior hacksaw and file.

Secure the shower to the wall with appropriate wall fixings.