



Built from experience



USER GUIDE & INSTALLATION INSTRUCTIONS

Professional+ 100 FX Dual Fuel

Show off your kitchen with ...

This is #MyRangemaster

RANGEmaster

Simply snap and share a picture of your kitchen and tag #MyRangemaster for the chance to win £200 of Rangemaster cookware. If selected we will also send a photographer round to professionally photograph you at home with your range. You might even feature in some of the UK's top home interest titles!

To enter all you have to do is send in photos of your Rangemaster kitchen and tell us in one sentence **what makes Rangemaster the heart of your kitchen?** Entries can be posted on our Facebook page, Instagram or Twitter by tagging @RangemasterUK and using #MyRangemaster. Or, if you prefer, simply send in your entry via e-mail to marketing@agarangemaster.co.uk.

Rangemaster will feature a number of entries on the website online gallery and on the Rangemaster Facebook page, and some kitchens may be selected to be professionally photographed.

*Terms & Conditions Apply

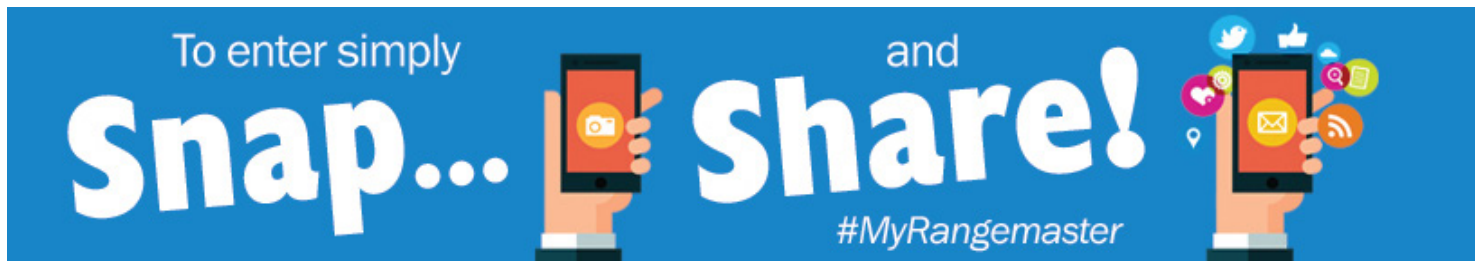

RANGEmaster COOKWARE

Our range cookers are well known for providing the best possible cooking performance and years of faithful service.

However, a great cooker alone cannot guarantee perfect results every time. The other vital ingredients are of course enthusiasm and quality cookware.

We offer cookware to work perfectly with all fuel types manufactured by Rangemaster, including induction hobs. You can be assured of functionality with style, as well as the quality and meticulous attention to detail you expect from the pioneers of range cooking.

Visit www.rangemastercookshop.co.uk



*Terms & Conditions

1. This is my Rangemaster is open to residents of UK mainland only, aged 18 years & over. 2. All entries should be submitted to the advertised e-mail address, or Rangemaster UK Facebook, Instagram or Twitter page using the advertised hashtag & tag. 3. If we would like to professionally photograph your kitchen, you will be contacted via e-mail, Facebook / Twitter message or Instagram comment. 4. We cannot guarantee your kitchen will be professionally photographed. 4. Any photographs received and professional photographs taken will belong to AGA Rangemaster plc with full usage rights. E&OE.

Contents

1. Before You Start...	1	7. Troubleshooting	19
Important!	1	8. Installation	21
Installation and Maintenance	1	Dear Installer	21
Peculiar smells	1	Safety Requirements and Regulations	21
If you smell gas	1	Provision of Ventilation	21
Ventilation	1	Location of Cooker	22
Personal Safety	1	Conversion	22
Cooker Care	2	Positioning the Cooker	23
Cleaning	2	Moving the Cooker	23
2. Cooker Overview	3	Completing the Move	24
Hotplate Burners	3	Fitting the Stability Bracket or Chain	24
Wok Burner	4	Conversion to Another Gas	25
The Wok Cradle	4	Levelling	25
The Griddle	5	Gas Connection	25
The Multifunction Ovens	6	Electrical Connection	26
The Ovens	8	Final Checks	26
Accessories	9	Fitting the Plinth	26
Oven Lights	9	Customer Care	26
Storage	9	To fit the drawer	27
3. The Clock	10	To remove the drawer	27
4. Cooking Tips	13	9. Circuit Diagram	28
Cooking with a Multifunction Oven	13	10. Technical Data	29
Tips on Cooking with the Timer	13	Connections	29
General Oven Tips	13	Dimensions	29
5. Cooking Table	14	Hotplate Ratings	29
6. Cleaning Your Cooker	15	Hotplate Efficiency	30
Essential Information	15	Oven Data	31
Hotplate Burners	15		
The Wok Cradle	15		
The Griddle	15		
Control Panel and Doors	16		
Cleaning Table	18		

1. Before You Start...

Your cooker should give you many years of trouble-free cooking if installed and operated correctly. It is important that you read this section before you start, particularly if you have not used a dual fuel cooker before.

Important!

⚠ This appliance is designed for domestic cooking only. Using it for any other purpose could invalidate any warranty or liability claim. In particular, the oven should NOT be used for heating the kitchen – besides invalidating claims this wastes fuel and may overheat the control knobs.

⚠ This appliance is for use in Great Britain and the Republic of Ireland. It is a Cat II2H3+ cooker and is set for G20 at 20mbar. (A conversion kit for LPG is supplied with the cooker).

Installation and Maintenance

In the UK, the cooker must be installed by a Gas Safe registered engineer. The electrical installation should be in accordance with BS 7671. Otherwise, all installations must be in accordance with the relevant instructions in this booklet, with the relevant national and local regulations, and with the local gas and electricity supply companies' requirements.

Ensure that the gas supply is turned on and that the cooker is wired in and switched on (the cooker needs electricity).

Set the clock to ensure that the oven is functional – see the relevant section in this manual.

It is recommended that this appliance is serviced annually.

Only a qualified service engineer should service the cooker, and only approved spare parts should be used.

Always allow the cooker to cool and then switch it off at the mains before cleaning or carrying out any maintenance work, unless specified otherwise in this guide.

Peculiar smells

When you first use your cooker it may give off a slight odour. This should stop after a little use.

Before using for the first time, make sure that all packing materials have been removed and then, to dispel manufacturing odours, turn the ovens to 200°C and run for an hour.

Before using the grill for the first time you should also turn on the grill and run for 30 minutes with the grill pan in position, pushed fully back, and the grill door open.

Make sure the room is well ventilated to the outside air (see 'Ventilation' below). People with respiratory or allergy problems should vacate the area for this brief period.

If you smell gas

- **DO NOT** turn electric switches on or off.
- **DO NOT** smoke
- **DO NOT** use naked flames
- **DO** turn off the gas at the meter or cylinder
- **DO** open doors and windows to get rid of the gas
- **DO** keep people away from the area affected
- Call your gas supplier.

If you are using natural gas in the UK, ring the National Grid on: 0800 111 999.

Ventilation

The use of a gas cooking appliance results in the production of heat and moisture in the room in which it is installed. Therefore, ensure that the kitchen is well ventilated: keep natural ventilation holes open or install a powered cooker hood that vents outside. If you have several burners on, or use the cooker for a long time, open a window or turn on an extractor fan.

Personal Safety

⚠ Do not modify this appliance.

⚠ This appliance can be used by children aged from 8 years and above and persons with reduced physical, sensory or mental capabilities or lack of experience and knowledge if they have been given supervision or instruction concerning use of the appliance in a safe way and understand the hazards involved. Children shall not play with the appliance. Cleaning and user maintenance shall not be made by children without supervision.

⚠ This appliance is not intended for use by young children or infirm persons unless they have been adequately supervised by a responsible person to make sure that they can use the appliance safely.

⚠ CAUTION: A long term cooking process has to be supervised from time to time. A short term cooking process has to be supervised continuously.

⚠ Danger of fire: DO NOT store items on the cooking surfaces.

⚠ To avoid overheating, DO NOT install the cooker behind a decorative door.

⚠ WARNING: The appliance and its accessible parts become hot during use and will retain heat even after you have stopped cooking. Care should be taken to avoid touching heating elements. Children less than 8 years of age shall be kept away unless continuously supervised.

⚠ DO NOT use a steam cleaner on your cooker.

- ⚠ **Accessible parts will become hot during use and will retain heat even after you have stopped cooking. Keep babies and children away from the cooker and never wear loose-fitting or hanging clothes when using the appliance.**

Always be certain that the controls are in the OFF position when the oven is not in use, and before attempting to clean the cooker.

- ⚠ **When the oven is on, DO NOT leave the oven door open for longer than necessary, otherwise the control knobs may become very hot.**
- ⚠ **DO NOT use harsh abrasive cleaners or sharp metal scrapers to clean the oven door glass since they can scratch the surface, which may result in shattering of the glass.**

Always keep combustible materials, e.g. curtains, and flammable liquids a safe distance away from your cooker.

- ⚠ **Never store flammable materials in the drawer. This includes paper, plastic and cloth items, such as cookbooks, plastic ware and towels, as well as flammable liquids. Do not store explosives, such as aerosol cans, on or near the appliance.**
- ⚠ **DO NOT spray aerosols in the vicinity of the cooker while it is on.**

Use dry oven gloves when applicable – using damp gloves might result in steam burns when you touch a hot surface. Do not use a towel or other bulky cloth in place of a glove – it might catch fire if brought into contact with a hot surface.

- ⚠ **NEVER operate the cooker with wet hands.**
- ⚠ **DO NOT use aluminium foil to cover shelves, linings or the oven roof.**
- ⚠ **DO NOT use hotplate protectors, foil or hotplate covers of any description. These may affect the safe use of your hotplate burners and are potentially hazardous to health.**
- ⚠ **NEVER heat unopened food containers. Pressure build up may make the containers burst and cause injury.**
- ⚠ **DO NOT use unstable saucepans. Always ensure that you position the handles away from the edge of the hotplate.**
- ⚠ **DO NOT use cooking vessels on the hotplate that overlap the edges.**

Never leave the hotplate unattended at high heat settings. Pans boiling over can cause smoking, and greasy spills may catch on fire. Use a deep fat thermometer whenever possible to prevent fat overheating beyond the smoking point.

- ⚠ **WARNING! Unattended cooking on a hob with fat or oil can be dangerous and may result in fire.**

- ⚠ **NEVER leave a chip pan unattended. Always heat fat slowly, and watch as it heats. Deep fry pans should be only one third full of fat. Filling the pan too full of fat can cause spill over when food is added. If you use a combination of oils or fats in frying, stir them together before heating or as the fats melt.**

Foods for frying should be as dry as possible. Frost on frozen foods or moisture on fresh foods can cause hot fat to bubble up and over the sides of the pan. Carefully watch for spills or overheating of foods when frying at high or medium high temperatures. Never try to move a pan of hot fat, especially a deep fat fryer. Wait until the fat is cool.

- ⚠ **DO NOT use the top of the flue (the slot along the back of the cooker) for warming plates, dishes, drying tea towels or softening butter.**
- ⚠ **DO NOT use water on grease fires and never pick up a flaming pan. Turn the controls off and then smother a flaming pan on a surface unit by covering the pan completely with a well fitting lid or baking tray. If available, use a multipurpose dry chemical or foam-type fire extinguisher.**

Cooking high moisture content foods can create a 'steam burst' when the oven door is opened (Fig. 1.1). When opening the oven stand well back and allow any steam to disperse.

Take care that no water seeps into the appliance.

- ⚠ **This appliance is heavy so take care when moving it.**

Cooker Care

As steam can condense to water droplets on the cool outer trim of the oven, it may be necessary during cooking to wipe away any moisture with a soft cloth. This will also help to prevent soiling and discolouration of the oven exterior by cooking vapours.

Cleaning

In the interests of hygiene and safety, the cooker should be kept clean at all times as a build up in fats and other food stuff could result in a fire.

Clean only the parts listed in this guide.

Clean with caution. If a wet sponge or cloth is used to wipe spills on a hot surface, be careful to avoid steam burns. Some cleansers can produce noxious fumes if applied to a hot surface.

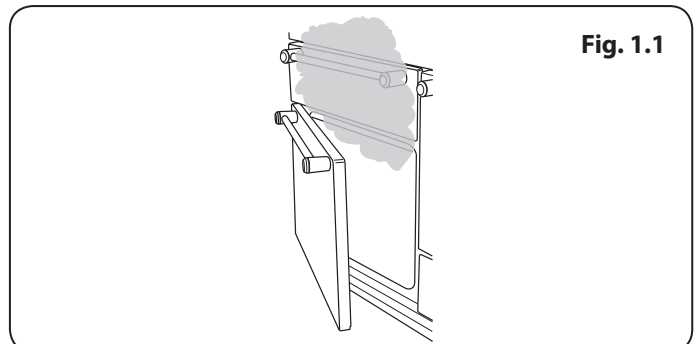

Fig. 1.1

2. Cooker Overview



Fig. 2.1

The 100 dual fuel cooker (**Fig. 2.1**) has the following features:

- A.** 5 hotplate burners including a wok burner
- B.** A control panel incorporating a timer
- C.** Main multifunction oven
- D.** Multifunction oven
- E.** Storage drawer

Hotplate Burners

The drawing by each of the control knobs indicates which burner that knob controls.

Each burner has a Flame Supervision Device (FSD) that prevents the flow of gas if the flame goes out.

When the igniter button is pressed in, sparks will be made at every burner – this is normal. Do not attempt to disassemble or clean around any burner while another burner is on, otherwise an electric shock could result.

To light a burner, push in and turn the associated control knob to the high position as indicated by the large flame symbol (🔥), (**Fig. 2.2**).

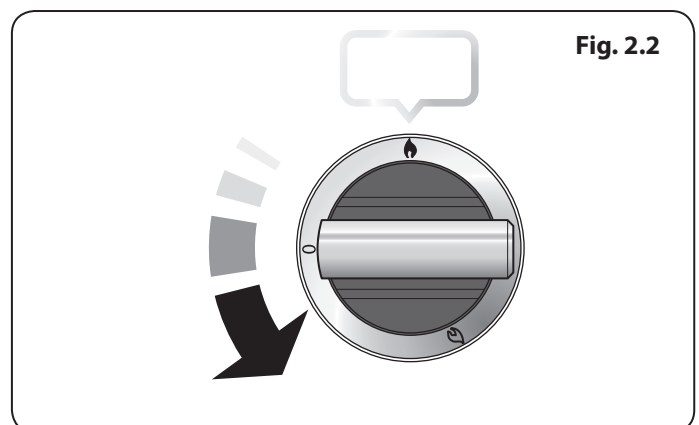
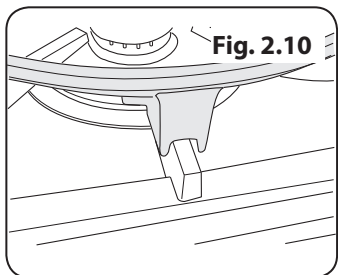
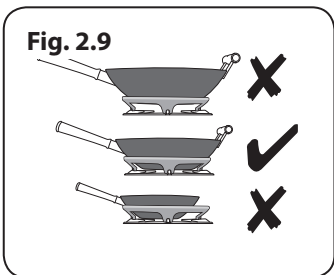
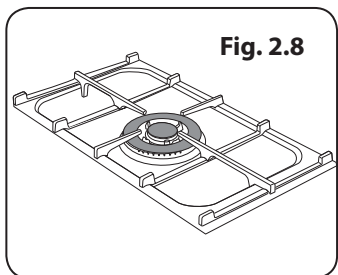
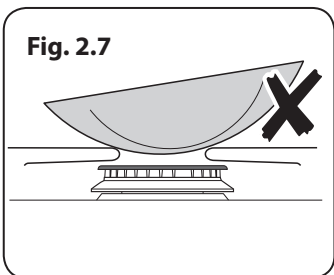
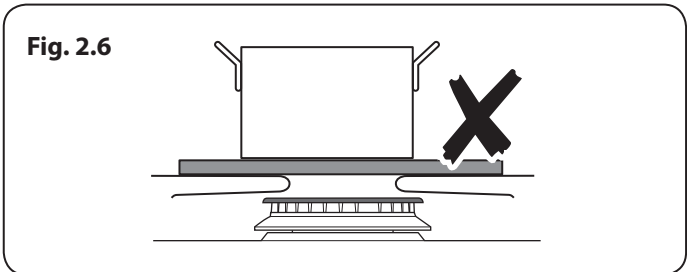
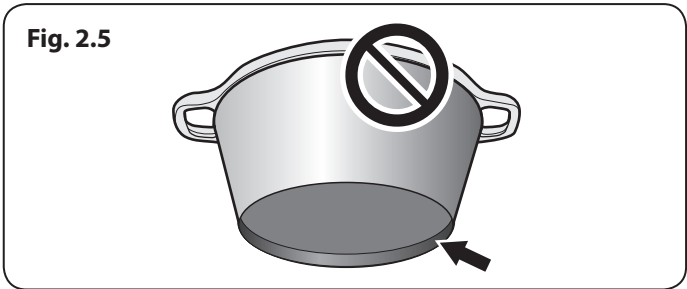
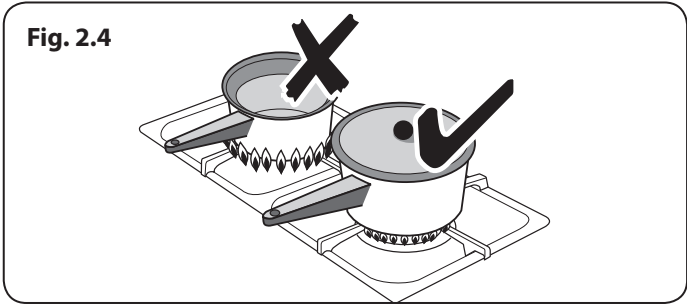
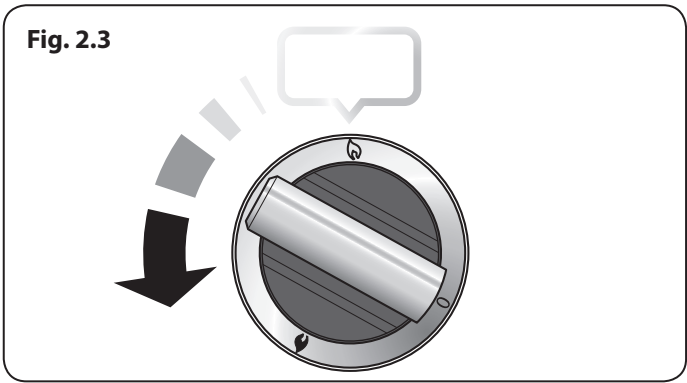

Fig. 2.2



The igniter should spark and light the gas. Keep holding the knob pressed in to let the gas through to the burner for about ten seconds.

If, when you let go of the control knob, the burner goes out, then the FSD has not been bypassed. Turn the control knob to the 'OFF' position and wait for one minute before you try again, this time making sure to hold in the control knob for slightly longer.

Adjust the flame height to suit by turning the knob counter-clockwise (**Fig. 2.3**). On this cooker the low position is beyond high, NOT between high and off.

If a burner flame goes out, turn off the control knob and leave it for one minute before relighting it.

Make sure that the flames are under the pans. Using a lid will help the contents boil more quickly (**Fig. 2.4**).

Large pans should be spaced well apart.

Pans and kettles with concave bases or down-turned base rims should not be used (**Fig. 2.5**).

Simmering aids, such as asbestos or mesh mats, are NOT recommended (**Fig. 2.6**). They will reduce burner performance and could damage the pan supports.

You should also avoid using unstable and misshapen pans that may tilt easily, and pans with a very small base diameter, e.g. milk pans, single egg poachers (**Fig. 2.7**).

The minimum recommended pan diameter is 120 mm. The maximum allowable pan base diameter is 260 mm.

DO NOT use cooking vessels on the hotplate that overlap the edges.

Wok Burner

The wok burner is designed to provide even heat over a large area. It is ideal for large pans and stir-frying (**Fig. 2.8**).

For heating smaller pans, the aforementioned hotplate burners may be more efficient.

You should wipe the enamel top surface of the cooker around the hotplate burners as soon as possible after spills occur. Try to wipe them off while the enamel is still warm.

Note: The use of aluminium pans may cause metallic marking of the pan supports. This does not affect the durability of the enamel and may be cleaned off with an appropriate metal cleaner.

The Wok Cradle

The wok cradle is designed to fit a 35 cm wok. If you use a different wok, make sure that it fits the cradle. Woks vary very widely in size and shape. It is important that the wok sits down on the pan support – however, if the wok is too small, the cradle will not support it properly (**Fig. 2.9**).

The cradle should be used on the wok burner only. When you fit the cradle, make sure that it is supported properly on a pan support and the wok is sitting level in the cradle (**Fig. 2.10**).

The cradle will get very hot in use – allow plenty of time for it to cool before you pick it up.

The Griddle

The griddle fits the left-hand pan support, front to back (**Fig. 2.11**). It is designed for cooking food on directly. DO NOT use pans of any kind on it. The griddle surface is non-stick and metal cooking utensils (e.g. spatulas) will damage the surface. Use heat resistant plastic or wooden utensils.

⚠ DO NOT put it crossways – it will not fit properly and will be unstable (Fig. 2.12).

⚠ DO NOT put it on any other burner – it is not designed to fit in any of the other pan supports.

Position the griddle over the hotplate burners resting on the pan support. Check that it is securely located.

The griddle can be lightly brushed with cooking oil before use or alternatively brush oil onto the food to be cooked (**Fig. 2.13**). Light the hotplate burners. Adjust the flame heights to suit.

Preheat the griddle for **a maximum of 5 minutes** before adding food. Leaving it longer may cause damage. Turn the control knobs towards the low position, marked with the small flame symbol, to reduce the burner flames.

⚠ Always leave space around the griddle for the gases to escape.

⚠ NEVER fit two griddles side by side (Fig. 2.14).

After cooking, allow the griddle to cool before cleaning.

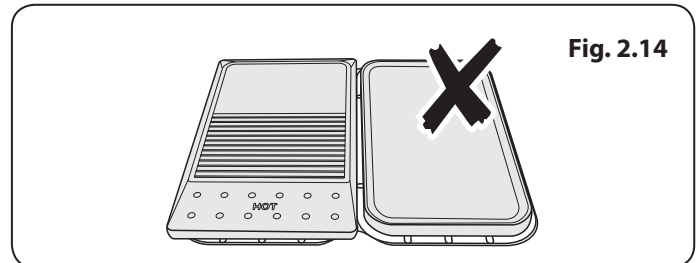
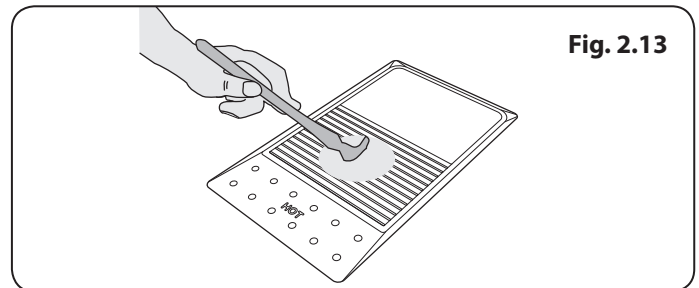
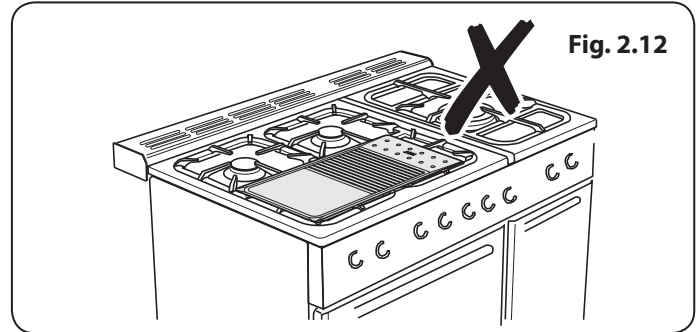
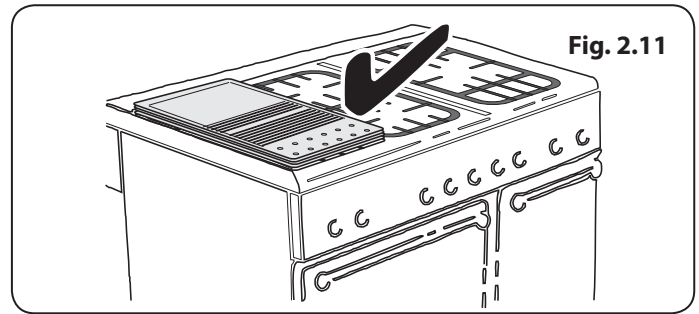

Function	Use
Defrost	To thaw small items in the oven without heat
Fan oven	A full cooking function, even heat throughout, great for baking
Fanned grilling	Grilling meat and fish with the door closed
Fan assisted	A full cooking function good for roasting and baking
Conventional oven	A full cooking function for roasting and baking in the lower half of the oven
Browning element	To brown and crisp cheese topped dishes
Base heat	To crisp up the bases of quiche, pizza or pastry

Table 2.1

Function	Use
Grilling	Grilling meat and fish with the door closed
Conventional oven	A full cooking function for roasting
Browning element	To brown and crisp cheese topped dishes
Base heat	To crisp up the bases of quiche, pizza or pastry

Table 2.2

The Multifunction Ovens

Both ovens are multifunction ovens. In addition to the element around the fan, it is fitted with extra heating elements, in the top of the oven and under the oven base. Take care to avoid touching the top elements when placing or removing items from the oven.

The left-hand multifunction oven has 3 main cooking functions: **fan**, **fan assisted** and **conventional cooking**. These functions should be used to complete most of your cooking.

The **browning element** and **base heat** can be used in the latter part of the cooking process to fine tune the results to your particular requirements.

Use **fanned grilling** for all your grilling needs and **defrost** to safely thaw small items of frozen food.

Table 2.1 gives a summary of the multi-function modes. The multi-function oven has many varied uses. We suggest you keep a careful eye on your cooking until you are familiar with each function. Remember, not all functions will be suitable for all food types.

Left-hand Multifunction Oven Modes

Defrost



This function operates the fan to circulate cold air only. Make sure the temperature control is at 0°C and that no heat is applied. This enables small items such as desserts, cream cakes and pieces of meat, fish and poultry to be defrosted.

Defrosting in this way speeds up the process and protects the food from contamination. Pieces of meat, fish and poultry should be placed on a shelf, over a tray to catch any drips. Be sure to wash the shelf and tray after defrosting.

Defrost with the oven door closed. Defrosting should not be carried out in a warm oven. Large items, such as whole chickens and meat roasts should not be defrosted in this way. We recommend this be carried out in a refrigerator. Make sure that dairy foods, meat and poultry are completely defrosted before cooking.

Fan Oven



This function operates the fan and the heating element around them. An even heat is produced throughout the oven, allowing you to cook large amounts quickly.

Fan oven cooking is particularly suitable for multi-shelf cooking and is a good 'all-round' function. It may be necessary to reduce the temperature by approximately 10°C for recipes previously cooked in a conventional oven.

If you wish to preheat the oven, wait until the indicator light has gone out before inserting the food.

Fanned Grilling



This function operates the fan while the top element is on. It produces a more even, less fierce heat than a conventional grill. For best results place the food to be grilled on the pan provided. Thick pieces of meat or fish are ideal for cooking in this way, as the circulated air reduces the fierceness of the heat from the grill. The oven door should be kept closed while cooking is in progress, so saving energy. You will also find that the food needs to be watched and turned less than for normal grilling. Preheat this function before cooking.

Note: When grilling full width, to allow sufficient access for tending foods we recommend placing the grill pan tray support on the second from top level.

Fan Assisted Oven



This function operates the fan, circulating air heated by the elements at the top and the base of the oven. The combination of fan and conventional cooking (Top and Base Heat) makes this function ideal for cooking large items that need thorough cooking, such as a large meat roast. It is also possible to bake on two shelves at one time, although they will need to be changed over during the cooking time, as the heat at the top of the oven is greater than at the base, when using this function.

This is a fast intensive form of cooking; keep an eye on the food cooking until you are familiar with this function.

Conventional Oven (Top and Base Heat)



This function combines the heat from the top and base elements. It is particularly suitable for roasting and baking pastry, cakes and biscuits.

Food cooked on the top shelf will brown and crisp faster than on the lower shelf, because the heat is greater at the top of the oven than at the base, as in 'Fan Assisted Oven' function. Similar items being cooked will need to be swapped around for even cooking. This means that foods requiring different temperatures can be cooked together, using the cooler zone in the lower half of the oven and hotter area to the top.

The exposed top element may cook some foods too quickly, so we recommend that the food be positioned in the lower half of the oven to cook. The oven temperature may also need to be lowered.

Browning Element



This function uses the element in the top of the oven only. It is a useful function for the browning or finishing of pasta dishes, vegetables in sauce and lasagne, the item to be browned being already hot before switching to the top element.

Base Heat



This function uses the base element only. It will crisp up your pizza or quiche base or finish off cooking the base of a pastry case on a lower shelf. It is also a gentle heat, good for slow cooking of casseroles in the middle of the oven or for plate warming.

The Browning and Base Heat functions are useful additions to your oven, giving you flexibility to finish off items to perfection. With use, you will soon realize how these functions can combine to extend your cooking skills.

Right-hand Multifunction Oven Modes

Table 2.2 gives a summary of the right-hand multi-function modes. The multi-function oven has many varied uses. We suggest you keep a careful eye on your cooking until you are familiar with each function. Remember, not all functions will be suitable for all food types.

Grilling



For best results place the food to be grilled on the pan provided. The oven door should be kept closed while cooking is in progress. Preheat this function before cooking. Place the pan on shelf level 4 or 5 depending on what is being cooked.

Conventional Oven (Top and Base Heat)



This function combines the heat from the top and base elements. It is particularly suitable for roasting and baking pastry, cakes and biscuits.

Food cooked on the top shelf will brown and crisp faster than on the lower shelf, because the heat is greater at the top of the oven than at the base. Similar items being cooked will need to be swapped around for even cooking. This means that foods requiring different temperatures can be cooked together, using the cooler zone in the lower half of the oven and hotter area to the top.

The exposed top element may cook some foods too quickly, so we recommend that the food be positioned in the lower half of the oven to cook. The oven temperature may also need to be lowered.

Browning Element



This function uses the element in the top of the oven only. It is a useful function for the browning or finishing of pasta dishes, vegetables in sauce and lasagne, the item to be browned being already hot before switching to the top element.

Base Heat



This function uses the base element only. It will crisp up your pizza or quiche base or finish off cooking the base of a pastry case on a lower shelf. It is also a gentle heat, good for slow cooking of casseroles in the middle of the oven or for plate warming.

The Browning and Base Heat functions are useful additions to your oven, giving you flexibility to finish off items to perfection. With use, you will soon realize how these functions can combine to extend your cooking skills.

Fig. 2.15

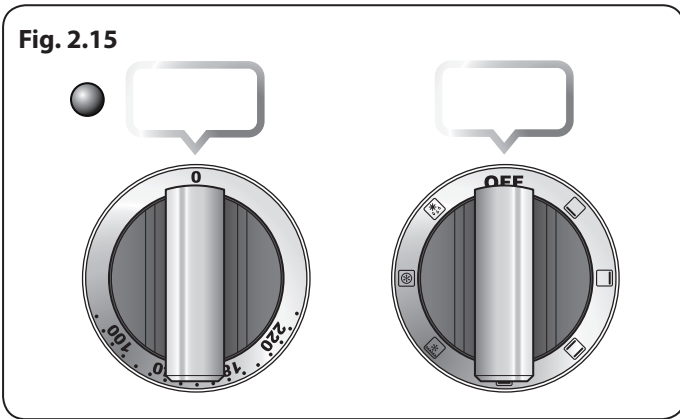

The Ovens

The clock must be set to the time of day before the left-hand oven will work. See the following section on 'The Clock' for instructions on setting the time of day. The clock only controls the left-hand oven.

References to 'left-hand' and 'right-hand' ovens apply as viewed from the front of the appliance.

Note: Please remember that all cookers vary so temperatures in your new ovens may differ to those in your previous cooker.

Operating the Ovens

1. Turn the oven knob to the desired temperature (**Fig. 2.15**).
2. The oven indicator light will glow until the oven has reached the temperature selected (**Fig. 2.15**). It will then cycle on and off during cooking.

Accessories

Oven Shelves – Left-hand (Main) Oven

The left-hand oven is supplied with two flat shelves (Fig. 2.16).

The oven shelves are retained when pulled forward but can be easily removed and refitted.

To refit the shelf, line up the shelf with a groove in the oven shelf supports and push the shelf back until the ends hit the shelf stop. Lift up the front so the shelf ends clear the shelf stops, and then lower the front so that the shelf is level and push it fully back (Fig. 2.17).

Oven Shelves – Right-hand Oven

The cooker is supplied with two standard shelves (Fig. 2.18).

The oven shelves can be easily removed and refitted.

Pull the shelf forward until the back of the shelf is stopped by the shelf stop bumps in the oven sides (Fig. 2.19).

Lift up the front of the shelf so the back of the shelf will pass under the shelf stop and then pull the shelf forward (Fig. 2.20).

Oven Lights

Press the button to turn the lights on (Fig. 2.21).

If the oven lights fail, turn off the power supply before changing the bulb. See the 'Troubleshooting' section for details on how to change the bulb.

Storage

The bottom drawer is for storing oven trays and other cooking utensils. The drawer can be removed completely for cleaning, etc.

- ⚠ It can get very warm, so do not store anything in it that may melt or catch fire.**
- ⚠ Never store flammable materials in the drawer. This includes paper, plastic and cloth items, such as cookbooks, plastic ware and towels, as well as flammable liquids.**
- ⚠ Do not store explosives, such as aerosol cans, on or near the appliance.**
- ⚠ Flammable materials may explode and result in fire or property damage.**

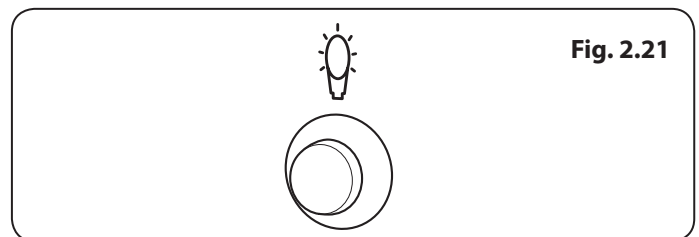
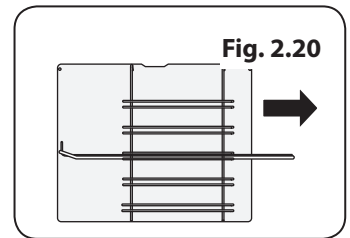
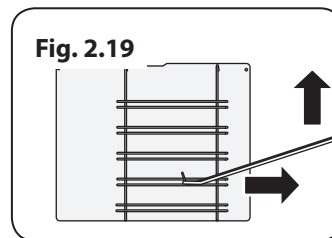
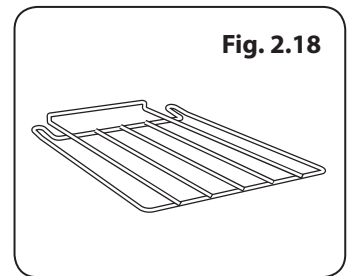
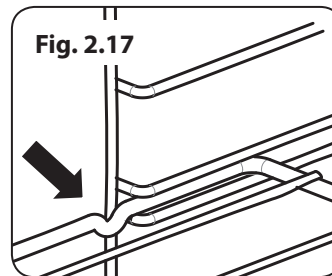
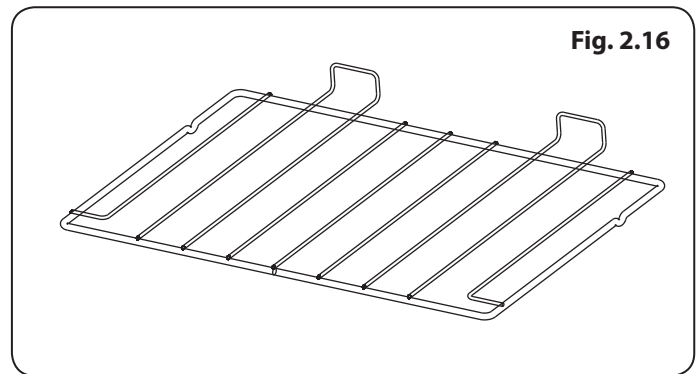

3. The Clock

Fig. 3.1

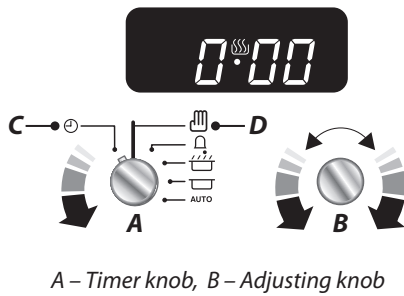

Fig. 3.2

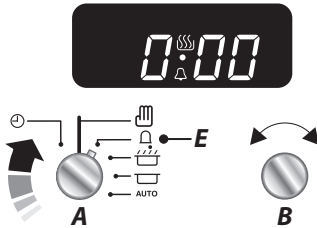

Fig. 3.3

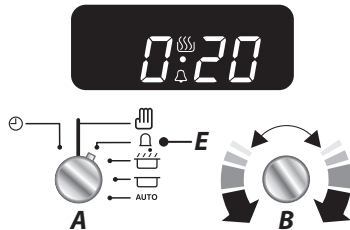
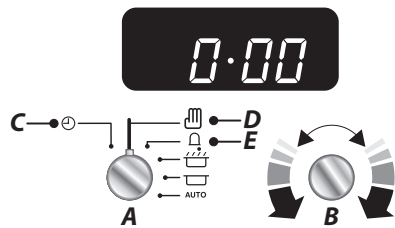

Fig. 3.4



The clock must be set to the time of day before the oven will work.

Setting the Clock

1. Once the cooker is connected and switched on, the display will start to flash.
2. To set the time, turn the **Timer (A)** knob to the **Clock (C)** setting and back to the **Manual (D)** position. The centre dot will flash indicating the time can be set. Turn the **Adjusting (B)** knob either clockwise or counter-clockwise (**Fig. 3.1**) to set the time.
3. Once you have set the time, allow the centre dot to stop flashing, the time is now set.

Setting the Minute Minder

A **Minute Minder (E)** is a feature that can be set for a number of minutes and sounds an alarm once the specified amount of time has elapsed.

1. Turn the **Timer (A)** knob to the **Minute Minder (E)** setting – it should click into position (**Fig. 3.2**).
2. Turn the **Adjusting (B)** knob to set the amount of time required. Minimum time 1 minute (**Fig. 3.3**).
3. Turn the **Timer (A)** knob back to the **Manual (D)** setting to see the current time and the 'Bell' symbol on the display.

Cancel the Timer Alarm

Once the specified time has elapsed it will emit an alarm. There are two ways to cancel the alarm:

1. Turn the **Adjusting (B)** knob counter-clockwise or clockwise (**Fig. 3.4**).
2. Turn the **Timer (A)** knob to the **Clock (C)** or the **Minute Minder (E)** setting, and back to the **Manual (D)** mode, to return to normal cooking (**Fig. 3.4**).

NOTE

If the alarm is not manually switched off it will stop after approximately 2 minutes.

When the Minute Minder is active the clock will not dim between the hours of 10 pm and 6 am

To Stop the Oven at a Specific Time of Day

You have set the required temperature and function mode and you would like the oven to automatically stop.

TOP TIP

Make a note of the current time so you do not forget.

1. Turn the **Timer (A)** knob to the **Stop Time (G)** setting. 'AUTO' will show in the display (**Fig. 3.5**).
2. Turn the **Adjusting (B)** knob to the amount of cooking time required. The display will show the current time plus the additional cooking time you have set (**Fig. 3.6**).
3. Turn the **Timer (A)** knob to the **Auto (H)** setting. The display will show the current time, the cooking symbol and the word 'AUTO' (**Fig. 3.7**).
4. Once the specified time has elapsed it will emit an alarm and the oven will stop working. The cook pot symbol on the display will disappear and the word 'AUTO' will flash (**Fig. 3.8**).
5. When you return, turn the **Timer (A)** knob to the **Manual (D)** setting to return to manual cooking (**Fig. 3.8**).

TOP TIP

You can check how much time you have left, to the programmed stop time, by turning Timer (A) from Auto (H) to Stop Time (G) and back to Auto (H)

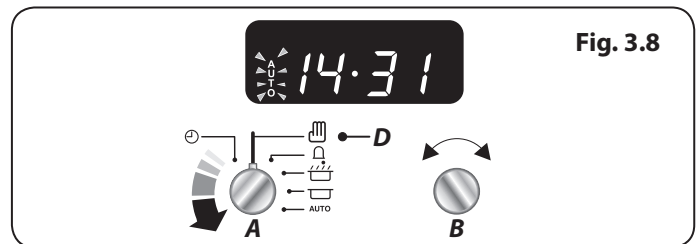
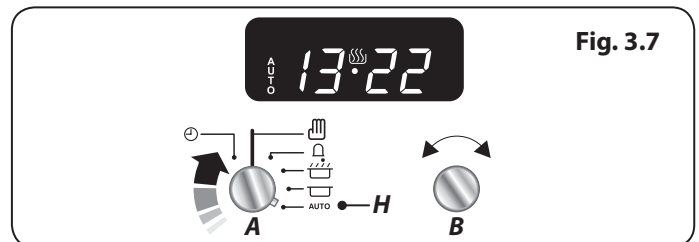
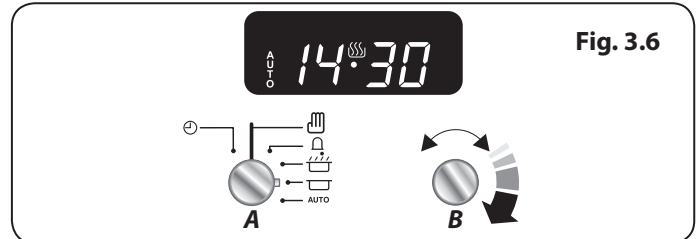
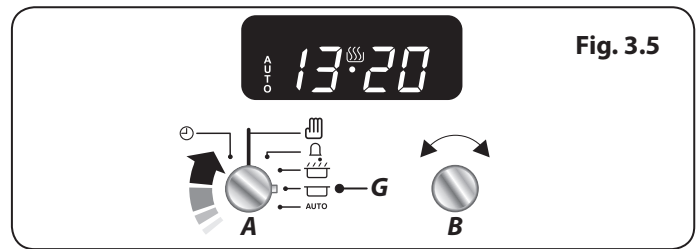

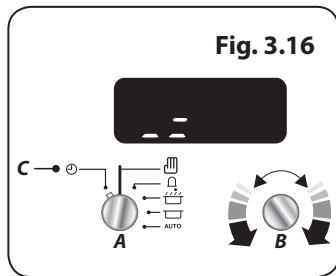
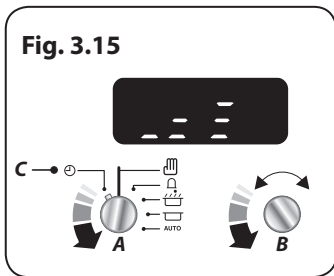
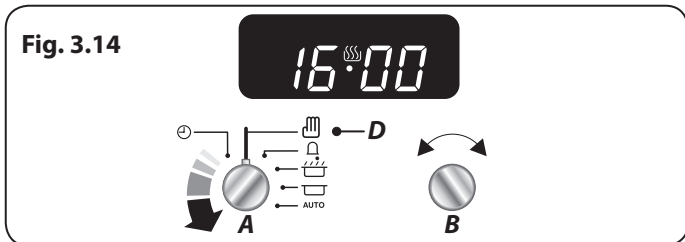
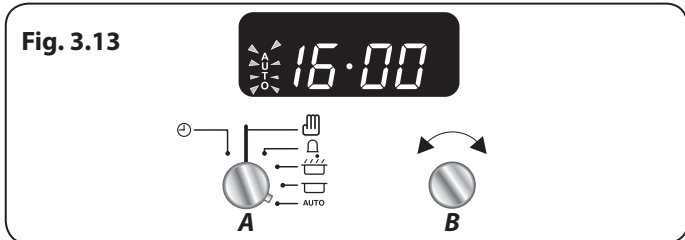
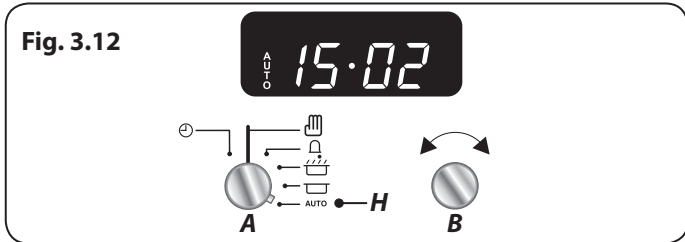
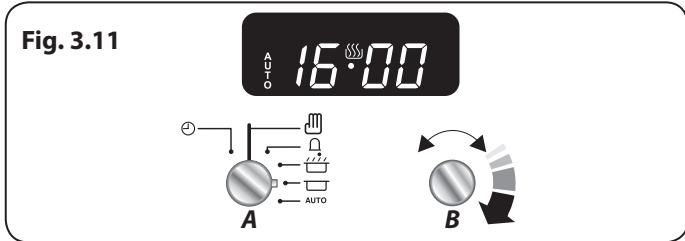
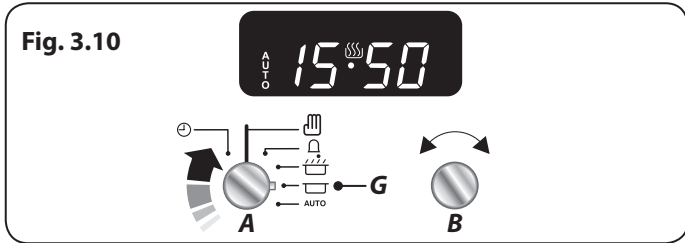
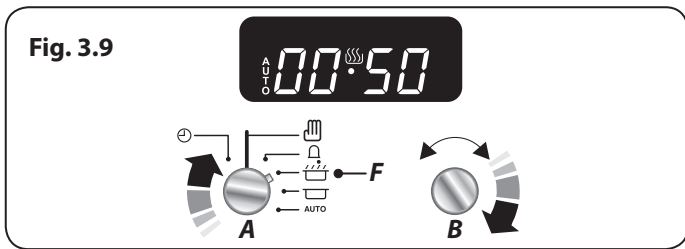

To Start and Stop the Oven Automatically

The timer allows you to automatically start and stop by a combination of the length of the cooking time and the stop time. Giving you the flexibility to cook casseroles etc while you are out. You cannot set the actual start time.

1. Turn the **Timer (A)** knob to the **Cook Time (F)** setting. Turn the **Adjusting (B)** knob clockwise to set the length of the cooking time required (**Fig. 3.9**).
2. Turn the **Timer (A)** knob to the **Stop Time (G)** setting (**Fig. 3.10**). The display will show the current time of day plus the 'cook time' you just set.
3. Turn the **Adjusting (B)** knob to set the time of day you want the oven to stop cooking (**Fig. 3.11**).
4. Set the oven to the required cooking temperature and function mode.
5. Turn the **Timer (A)** knob to the **Auto (H)** setting (**Fig. 3.12**). If the display shows the current time and the word 'AUTO' the oven is set to turn on and off.
6. When the program starts the oven, the cooking symbol will appear on the display. Once the specified time has elapsed it will emit an alarm and the oven will stop working. The 'Cooking' symbol on the display will disappear and the word 'AUTO' will flash (**Fig. 3.13**).
7. Once the specified time has elapsed it will emit an alarm. There are two ways to cancel the alarm, refer to "**Cancel the Timer Alarm**" on page 10

- The 'cook period', which is the length of time you want the oven to cook for.
- The 'stop time', which is the time of day you want the oven to stop cooking.

Reset to Manual Cooking

To cancel any automatic settings turn the **Timer (A)** knob to the **Manual (D)** setting and release (**Fig. 3.14**).

Note: Whilst this operation cancels all automatic program settings, it does not cancel the minute minder.

Beeper Tone Adjustment

The beeper tone can be adjusted to three different levels.

Turn the **Timer (A)** knob to the **Clock (C)** setting. Turn the **Adjusting (B)** knob counter clockwise until the tone bars are displayed (**Fig. 3.15**).

To adjust the tone of the alarm, release the **Adjusting (B)** knob and then turn counter clockwise again (**Fig. 3.16**). The tone of the alarm will change. Repeat these steps until the desired alarm tone is set.

4. Cooking Tips

Cooking with a Multifunction Oven

Remember: not all modes are suitable for all food types. The oven cooking times given are intended for a guide only.

Tips on Cooking with the Timer

If you want to cook more than one dish, choose dishes that require approximately the same cooking time. However, dishes can be 'slowed down' slightly by using small containers and covering them with aluminium foil, or 'speeded up' slightly by cooking smaller quantities or placing them in larger containers.

Very perishable foods such as pork or fish should be avoided if a long delay period is planned, especially in hot weather.

- ⚠ DO NOT place warm food in the oven to be timed.**
- ⚠ DO NOT use a timed oven that is already warm.**
- ⚠ DO NOT use the timed oven if the adjoining oven is already warm.**

Whole poultry must be thoroughly defrosted before being placed in the oven. Check that meat and poultry are fully cooked before serving.

General Oven Tips

The wire shelves should always be pushed firmly to the back of the oven.

Baking trays with food cooking on them should be placed level with the front edge of the oven's wire shelves. Other containers should be placed centrally. Keep all trays and containers away from the back of the oven, as overbrowning of the food may occur.

For even browning, the maximum recommended size of a baking tray is 340 mm (13½") by 340 mm (13½") in the main oven and 232 mm (9 1/8") by 321 mm (12 5/8") in the right-hand oven.

When the oven is on, do not leave the door open for longer than necessary, otherwise the knobs may get very hot.

- Always leave a "finger's width" between dishes on the same shelf in the main oven. This allows the heat to circulate freely around them.
- To reduce fat splashing when you add vegetables to hot fat around a roast, dry them thoroughly or brush lightly with cooking oil.
- Where dishes may boil and spill over during cooking, place them on a baking tray.
- If you want to brown the base of a pastry dish, preheat the baking tray for 15 minutes before placing the dish in the centre of the tray.

5. Cooking Table

The oven control settings and cooking times given in the table below are intended to be used **AS A GUIDE ONLY**. Individual tastes may require the temperature to be altered to provide a preferred result. Food is cooked at lower temperature in a fan oven than in a conventional oven. When using recipes, reduce the fan oven temperature by 10°C and the cooking time by 5-10 minutes. The temperature in the fanned oven does not vary with height in the oven so you can use any shelf. See 'Overview' and 'Cooking Tips' for more information.

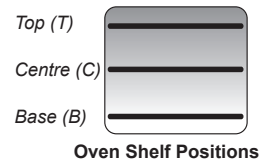

Food	Left-hand Oven	Right-hand Oven	Approximate Cooking Time		
	Fan function Temperature °C	Conventional function Centre shelf Temperature °C			
Meat					
Beef (no bone)	150	160	30-35 minutes per 500g +30-35 minutes.	<i>Thoroughly thaw frozen joints before cooking. Meat may be roasted at 220°C and the cooking time adjusted accordingly. For stuffed and rolled meats, add approximately 10 minutes per 500g, or cook at 200°C for 20 minutes then 160°C for the remainder.</i>	
	190	200	20-25 minutes per 500g +20-25 minutes.		
Lamb	150	160	30-35 minutes per 500g +30-35 minutes.		
	190	200	25-30 minutes per 500g +25-30 minutes.		
Pork	150	160	35-40 minutes per 500g +35-40 minutes.		
	190	200	25-30 minutes per 500g +25-30 minutes.		
Poultry					
Chicken	150	160	20-25 minutes per 500g +20-25 minutes.		<i>For stuffed poultry, you could cook at 200°C for 20 minutes then 160°C for remainder. Do not forget to include the weight of the stuffing. For fresh or frozen prepacked poultry, follow instructions on the pack. Thoroughly thaw frozen poultry before cooking.</i>
	190	200	15-20 minutes per 500g +15-20 minutes.		
Turkey	150	160	20 minutes per 500g +20 minutes.		
	190	200	15 minutes per 500g +15 minutes.		
Duck	150	160	25-30 minutes per 500g.		
	190	200	20 minutes per 500g.		
Casserole	130-140	140-150	2-4 hours according to recipe.		
Yorkshire pudding	210	220	Large tins 30-35 minutes; individual 10-20 minutes.		
Cake					
Very rich fruit - Christmas, wedding, etc.	130	140	45-50 minutes per 500g of mixture.		
Fruit 180 mm tin	140	150	2-2½ hours.		
Fruit 230 mm tin	140	150	Up to 3½ hours.		
Madeira 180 mm	150	160	80-90 minutes.	<i>Using the right-hand oven: when two tier cooking leave at least one runner space between shelves. Position the baking tray with the front edge along the front of the oven shelf.</i>	
Queen cakes	180	190	15-25 minutes.		
Scones	210	220	10-15 minutes.		
Victoria sandwich				<i>Up to three tiers can be cooked in a fan oven at the same time but make sure to leave at least one runner space between each shelf being cooked on.</i>	
180 mm tin	170	180	20-30 minutes.		
210 mm tin	170	180	30-40 minutes.		
Desserts					
Shortcrust tarts	180	190	20-30 minutes on a preheated tray.	<i>Using the right-hand oven: for even browning the maximum size of baking tray recommended is 232 mm x 321 mm. This ensures free heat circulation.</i>	
Fruit pies	180	190	35-45 minutes.		
Tartlets	180	190	10-20 minutes according to size.		
Puff pastry	210	220	20-40 minutes according to size.		
Meringues	90	100	2-3 hours.	<i>If cooking a two tier load, the trays should be interchanged approximately halfway though the cooking time.</i>	
Baked egg custard	150	160	45-60 minutes.		
Baked sponge pudding	180	190	40-45 minutes.		
Milk pudding	130-140	140-150	2 to 3 hours.		
Bread	210	220	20-30 minutes.		
Fish					
	Fanned	Grilling			
Fillet	180	190	15-20 minutes.		
Whole	180	190	15-20 minutes per 500g.		
Steak	180	190	Steaks according to thickness.		

6. Cleaning Your Cooker

Essential Information

Isolate the electricity supply before carrying out any thorough cleaning. Allow the cooker to cool.

⚠ NEVER use paint solvents, washing soda, caustic cleaners, biological powders, bleach, chlorine based bleach cleaners, coarse abrasives or salt.

⚠ DO NOT mix different cleaning products – they may react together with hazardous results.

All parts of the cooker can be cleaned with hot soapy water – **but take care that no surplus water seeps into the appliance.**

Remember to switch on the electricity supply and reset the clock before re-using the cooker.

Hotplate Burners

The burner heads and caps can be removed for cleaning.

⚠ DO NOT put the burner heads in a dishwasher.

Make sure they are absolutely dry before replacing them.

The Single Ring Burners

When refitting the burner head, make sure that the notch lines up with the electrode or hole in the base. Check that the burner head is level and that the cap is fitted centrally on the burner head (**Fig. 6.1**).

The Wok Burner

The Wok burner can also be taken apart for cleaning.

When reassembling the wok burner (**Fig. 6.2**), turn over the large base ring and find the 'D' shaped area (**Fig. 6.3**). Turn the head until the 'D' matches the one on the burner base. Flip the burner over once again and place it on the burner base.

To fit the small inner burner, find the larger electrode notch in the burner rim. Line this up with the white ignition electrode and place the inner burner on the large base ring (**Fig. 6.4**).

Now fit the two burner caps, making sure that they are seated properly.

Check the burner ports are not blocked. If a blockage occurs, remove stubborn particles using a piece of fuse wire.

The Wok Cradle

Recommended cleaning materials are hot soapy water, a moistened soap pad, cream cleaner or a nylon scourer.

The Griddle

Always clean the griddle after use. Allow it to cool completely before removing. Immerse the griddle plate in hot soapy water. Use a soft cloth or, for stubborn stains, a nylon washing up brush.

Note: If the griddle is washed in a dishwasher then some dishwasher residue may appear on the back. This is normal and will not affect the performance of your griddle.

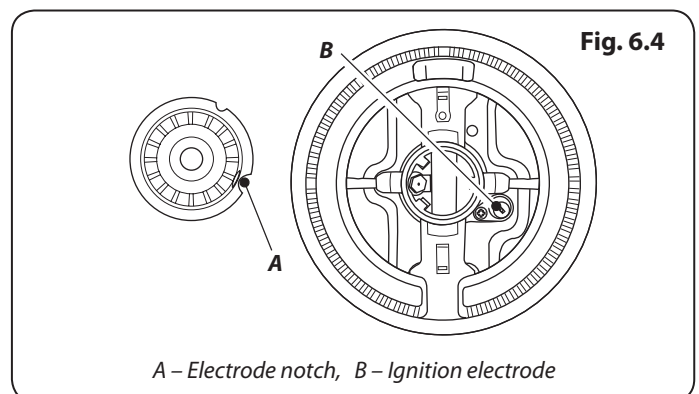
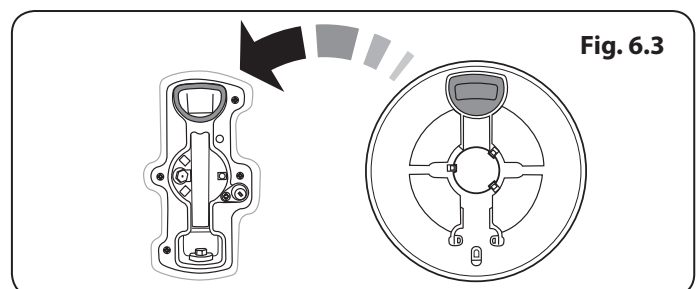
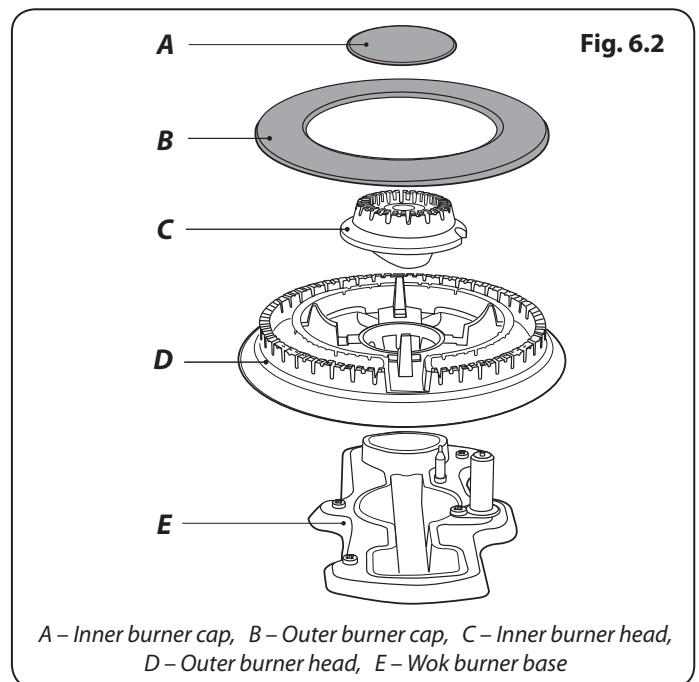
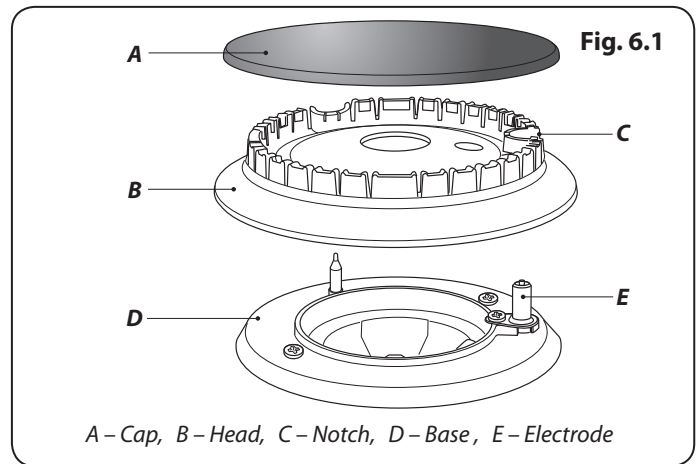

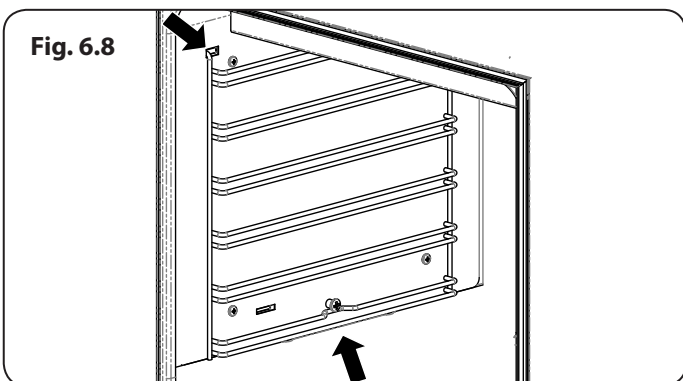
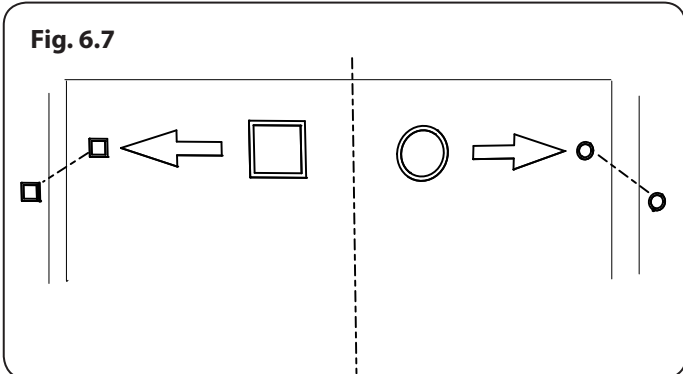
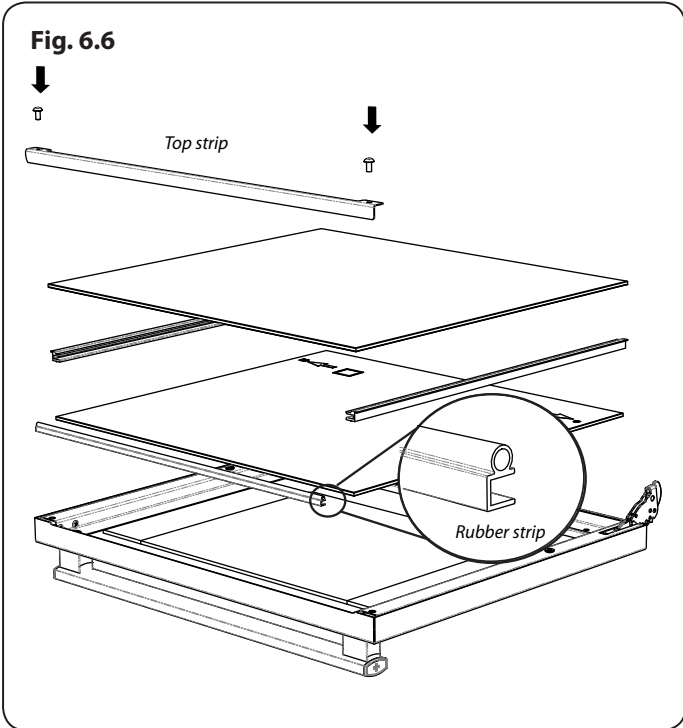
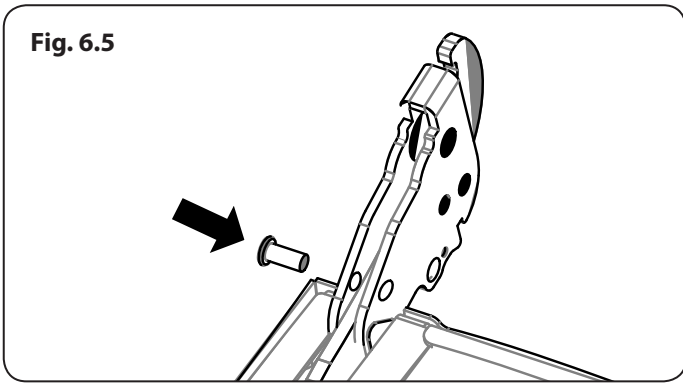

Control Panel and Doors

Avoid using any abrasive cleaners including cream cleaners. For best results, use a liquid detergent.

The same cleaner can be used on the doors, or alternatively, using a soft cloth wrung out in clean hot soapy water – but take care that no surplus water seeps into the appliance.

After cleaning, polish with a dry cloth.

Removing the Glass Fronted Door Panels

⚠ DO NOT use harsh abrasive cleaners or sharp metal scrapers to clean the oven door glass since they can scratch the surface, which may result in shattering of the glass.

Open the oven door fully and place the supplied holding pins in the drop down hinges (**Fig. 6.5**).

Remove the top 2 fixing screws using the Allen key supplied and the door top strip (**Fig. 6.6**). Then lift the 2 glass panels out.

To refit the door glass correctly, make sure that the printed circle and square on the glass, match up to the pressed holes of the same shape (**Fig. 6.7**). This will ensure the heat reflective side is in the correct position, facing towards the oven.

Make sure that the rubber strips are all attached.

After cleaning, carefully refit the door panel and remove the holding pins.

Removing the Left-hand Main Oven Linings

Some of the lining panels can be removed for cleaning. You will need to remove the shelves before removing the panels. To remove the oven shelf supports lift until clear of the two top supporting holes, and the middle fixing screw and pull outwards (**Fig. 6.8**).

To remove the side panels, take out the 5 fixing screws on each side, lift the panel and slide forwards.

To replace the liner, the cut-out section must be at the top of the liner. Slide the liner towards the back of the oven cavity. When this is in position you can replace the fixing screws and then the shelf supports. To do this, insert the top of the support into the cut-out section, relocating the support under the lower fixing screw to secure into place.

Removing the Right-hand Oven Shelf Supports

To clean the oven sides, slide out the shelves, unhook the shelf supports from the oven sides (**Fig. 6.9**), and lift out.

Refit in reverse, making sure that the bottom of the shelf supports are inserted into the holes at the bottom of the oven (**Fig. 6.10**), prior to hooking the top into position.

Removing the Right-hand Oven Cover Plate and Reflector Tray

Isolate the electricity supply before carrying out any thorough cleaning. Allow the cooker to cool.

Once the side supports have been removed (see above) the cover plate at the bottom of the oven can be taken out by unscrewing the 2 fixing screws at the back of the oven (**Fig. 6.11**).

Lift the cover plate out using the lip at the back, and carefully lift up and pull forward.

To remove the reflector tray from underneath the element, gently raise the element and remove the tray from between the element and the oven front.

When replacing the reflector tray, it is important to push the tray fully back into position (**Fig. 6.12**). To do this, gently lift the element and slide the tray to the back of the oven.

To replace the cover plate, tilt it up at the back to allow it to go under the front lip of the oven, making sure that the fixing holes are aligned at the rear of the cooker. Lower into position and replace the screws.

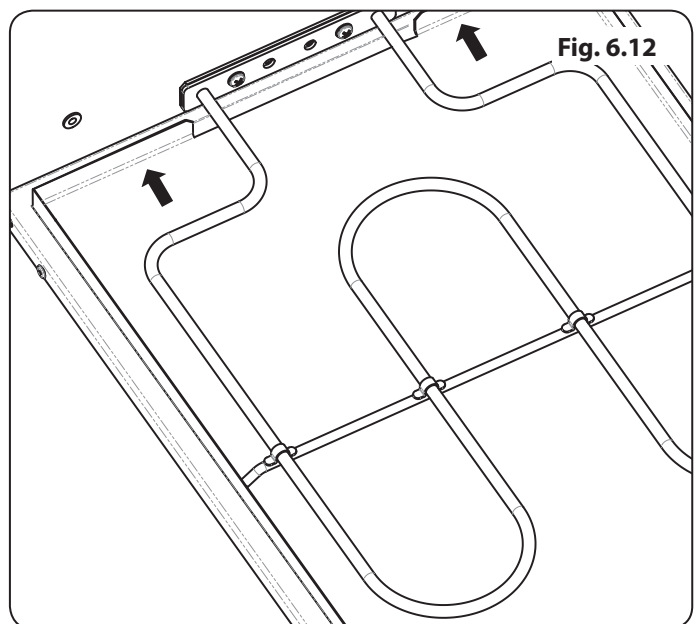
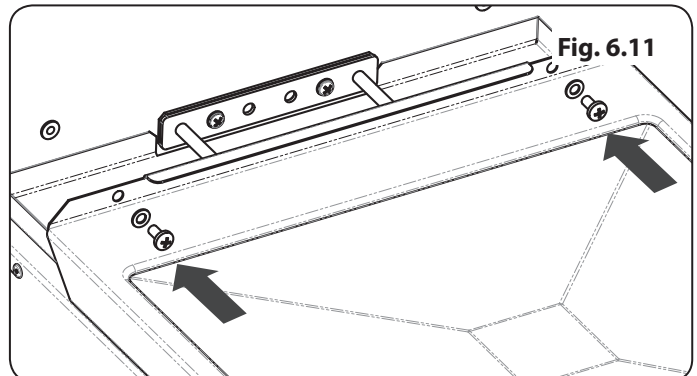
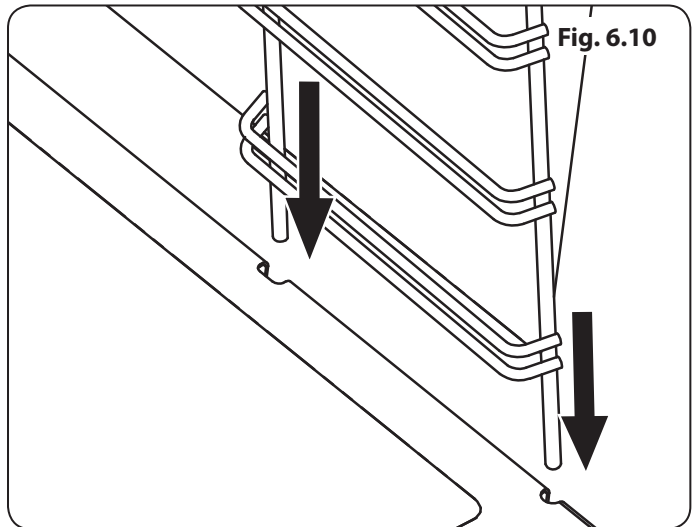
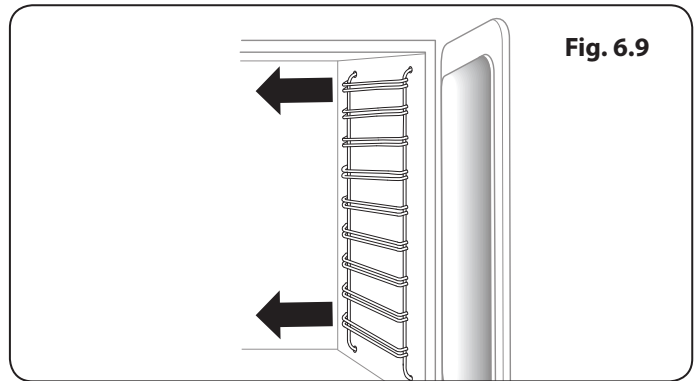

Cleaning Table

Cleaners listed (**Table 6.1**) are available from supermarkets or electrical retailers as stated.

For enamelled surfaces use a cleaner that is approved for use on vitreous enamel.

Regular cleaning is recommended. For easier cleaning, wipe up any spillages immediately.

Hotplate		
Part	Finish	Recommended Cleaning Method
Hob top (including burner heads and caps)	Enamel, stainless steel, aluminium	Hot soapy water, soft cloth. Any stubborn stains remove gently with a nylon scourer.
Griddle plate	Non-stick surface	Allow to cool. Wash in hot soapy water. Do not use abrasive cleaners/scourers. Dishwasher.
Outside of Cooker		
Part	Finish	Recommended Cleaning Method
Door, door surround & storage drawer exterior	Enamel or paint	Hot soapy water, soft cloth. Any stubborn stains, remove gently with a liquid detergent.
	Stainless steel	E-cloth (<i>electrical retailers</i>) or microfibre all-purpose cloth (<i>supermarket</i>).
Sides & plinth	Painted surface	Hot soapy water, soft cloth.
Rear grille	Enamel or stainless steel	Hot soapy water, soft cloth. Cream cleaner, with care, if necessary.
Control panel	Paint, enamel or stainless steel	Warm soapy water. Do not use abrasive cleaners on lettering.
Control knobs/handles & trims	Plastic/chrome, copper or lacquered brass	Warm soapy water, soft cloth.
	Brass	Brass polish.
Oven door glass	Toughened glass	Hot soapy water, cream cleaner/scourer if necessary.
Oven		
Part	Finish	Recommended Cleaning Method
Sides, floor & roof of oven	Enamel	Any proprietary oven cleaner that is suitable for enamel. CAUTION: CORROSIVE/CAUSTIC OVEN CLEANERS: FOLLOW MANUFACTURER'S INSTRUCTIONS. Do not allow contact with the oven elements. Use the minimum amount of liquid when cleaning the right-hand oven as you risk spilling it into the cover plate at the base of the oven.
Oven shelves & trivet	Chrome	An oven interior cleaner that is suitable for chrome. Soap filled pad. Dishwasher.
Grill pan/meat tin	Enamel	Hot soapy water. Soap filled pad. Dishwasher.

Table 6.1

7. Troubleshooting

Hotplate ignition or hotplate burners faulty

Is the power on? Is the clock illuminated?

If not, there maybe something wrong with the power supply.

Are the sparker (ignition electrode) or burner slots blocked by debris?

Are the burner trim and caps correctly located? See the section on 'Cleaning'?

Hotplate burners will not light

Make sure that the burner parts have been replaced correctly after wiping or removing for cleaning.

Check that there is not a problem with your gas supply. You can do this by making sure that other gas appliances you may have are working.

Do the burners spark when you push the control?

If not, verify that the power is on by checking that the clock is illuminated.

Steam is coming from the oven

When cooking foods with high water content (e.g. oven chips) there may be some steam visible at the rear grille.

Take care when opening the oven door, as there may be a momentary puff of steam when the oven door is opened. Stand well back and allow any steam to disperse.

What cleaning materials are recommended for the cooker?

See the 'Cleaning' section for recommended cleaning materials.

Never use caustic or abrasive cleaners as these will damage the surface.

An oven fan is noisy

The note of the oven fan may change as the oven heats up – this is perfectly normal.

The knobs get hot when I use the oven. Can I avoid this?

Yes, this is caused by heat rising from the oven and heating them up. Do not leave the oven door open.

The fascia gets hot when I use the oven

The cooker is cooled by a fan. If the fascia becomes excessively hot when the cooker is in use then the cooling fan may have failed. Should this occur please contact your installer, a qualified repair engineer or Customer Service to arrange for its repair.

If there is an installation problem and I don't get my original installer to come back to fix it who pays?

You do. Service organisations will charge for their call outs if they are correcting work carried out by your original installer. It is in your interest to track down your original installer.

Power failure

In the event of a failure in the electrical supply, remember to reset the clock to make sure that the timed oven continues to operate.

Food is cooking too slowly, too quickly, or burning

Cooking times may differ from your previous oven.

Check that you are using the recommended temperatures, shelf positions and tray sizes – see the oven cooking guide. The oven control settings and cooking times are intended to be used only as a guide.

Individual tastes may require the temperature to be altered either way, to get the results you want.

The oven is not cooking evenly

Do not use a baking tray with dimensions larger than those specified in the section on 'General Oven Tips'.

If you are cooking a large item, be prepared to turn it round during cooking.

If two shelves are used, check that space has been left for the heat to circulate. When a baking tray is put into the oven, make sure that it is placed centrally on the shelf.

Check that the door seal is not damaged and that the door catch is adjusted so that the door is held firmly against the seal.

A dish of water when placed on the shelf should be the same depth all over. (For example, if it is deeper at the back, then the back of the cooker should be raised up or the front lowered.) If the cooker is not level arrange for your supplier to level it for you.

Oven not coming on

Is the power on? Is the clock illuminated? If not, there may be something wrong with the power supply.

Is the cooker supply on at the isolator switch?

Has the time of day been set?

Is the key symbol [🔒] showing in the display to signify that the oven is locked? See the 'Clock' section of the instructions for more information on the key lock feature.

Fig. 7.1

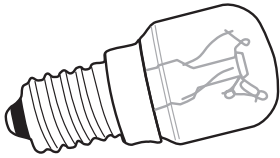
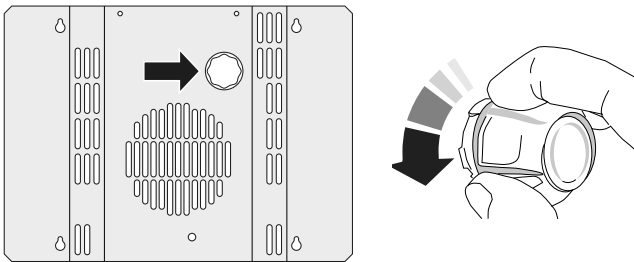

Fig. 7.2



The timed oven is not coming on when automatic cooking

Has the oven knob been left in the OFF position by mistake?

Is the oven locked (see above)?

Oven temperature getting hotter as the cooker gets older

If turning the temperature down using the oven control knob has not worked, or has only worked for a short time, then you may need a new thermostat. This should be fitted by a service person.

Oven lights are not working

The bulb has probably burnt out. You can buy a replacement bulb (which is not covered under the warranty) from a good electrical shop. Ask for a 15W – 230V lamp, FOR OVENS. It must be a special bulb, heat resistant to 300°C (**Fig.6-1**).

Turn off the power at the circuit breaker.

Before removing the existing bulb, turn off the power supply and make sure that the oven is cool. Open the oven door and remove the oven shelves.

Unscrew the bulb cover by turning counter-clockwise. It may be very stiff (**Fig.6-2**).

Taking care to protect your fingers with a glove in case the bulb should shatter, unscrew the old bulb.

Screw in the new bulb; screw back the bulb cover. Turn on the circuit breaker and check that the bulb now lights.

INSTALLATION

Check the appliance is electrically safe and gas sound when you have finished.







8. Installation

Dear Installer

Before you start your installation, please complete the details below, so that, if your customer has a problem relating to your installation, they will be able to contact you easily.

Installer's Name
Installer's Company
Installer's Telephone Number
Appliance Serial Number

Safety Requirements and Regulations

-  **This cooker must be installed in accordance with the relevant instructions in this booklet, with the relevant national and local regulations, and with the local gas and electricity supply companies' requirements.**
-  **This cooker is a Class 2 Subclass 1 appliance.**
-  **Before installation, make sure that the cooker is suitable for your gas type and supply voltage. See the data badge.**
-  **The appliance must be installed in accordance with the regulations in force and only in a well-ventilated space.**
-  **Read the instructions before installing or using this appliance.**
-  **In your own interest and that of safety, it is law that all gas appliances be installed by competent persons. Failure to install the appliance correctly could invalidate any warranty or liability claims and lead to prosecution.**
-  **This appliance can be converted for use on another gas.**

In the UK the cooker must be installed in accordance with:

- **All relevant British Standards / Codes of Practice, in particular BS 5440 Part 2.**
- **For Natural Gas – BS 6172 and BS 6891.**
- **For LP Gas – BS 5482-1 (when the installation is in a permanent dwelling), BS 5482-2 (when the installation is in a caravan or other non-permanent dwelling) or BS 5482-3 (when the installation is in a boat).**
- **The Gas Safety (Installation and Use) regulations.**
- **The relevant Building / IEE regulations.**

In the Republic of Ireland the cooker must be installed in accordance with:

The installation must be carried out by a competent person and installed in accordance with the current edition of IS 813 "Domestic Gas Installations", the current Building Regulations and reference should be made to the current ETCI rules for electrical installation.

Provision of Ventilation

This appliance is not connected to a combustion products evacuation device. Particular attention shall be given to the relevant requirements regarding ventilation.

All rooms require a window that can be opened, or equivalent, while some rooms require a permanent vent in addition to the window.

In the UK:

The room containing the cooker should have an air supply in accordance with BS 5440 Part 2. All rooms require an openable window or equivalent, while some rooms require a permanent vent in addition to the openable window. The cooker should not be installed in a bed sitting room with volume less than 20 m³. If it is installed in a room of volume less than 5 m³ an air vent of effective area 100 cm² is required; if it is installed in a room of volume between 5 m³ and 10 m³, an air vent of effective area 50 cm² is required; while if the volume exceeds 11 m³, no air vent is required.

If there are other fuel burning appliances in the same room, BS 5440 Part 2 should be consulted to determine the requisite air vent requirements.

In the Republic of Ireland:

Reference should be made to the current edition of IS 813, which makes clear the conditions that must be met to demonstrate that sufficient ventilation is available.

INSTALLATION

Check the appliance is electrically safe and gas sound when you have finished.

Location of Cooker

The cooker may be installed in a kitchen/kitchen diner but NOT in a room containing a bath or shower.

This appliance is designed for domestic cooking only. Use for any other purpose could invalidate any warranty or liability claim.

Note: An appliance for use on LPG must not be installed in a room or internal space below ground level, e.g. in a basement.

Conversion

This appliance is supplied set for G20 20 mbar Cat II_{2H3+}.

A conversion kit for another gas is available for the cooker.

If the appliance is to be converted to another gas we recommend that this is carried out before installation.

After converting the appliance, please attach the Gas Conversion sticker over the appropriate area of the data badge – this will identify the gas type for which the appliance is now set.

You will need the following equipment to complete the cooker installation satisfactorily:

- Stability bracket: If the cooker is to be supplied with gas through a flexible hose, a stability bracket or chain **MUST** be fitted. **These are not supplied with the cooker** but are available at most builders' merchants.
- Gas pressure tester/manometer.
- Flexible gas hose: Must be in accordance with the relevant standards.
- Multimeter: For electrical checks.

You will also need the following tools:

1. Electric drill
2. Masonry drill bit (only required if fitting the cooker on a stone or concrete floor)
3. Wall plugs (only required if fitting the cooker on a stone or concrete floor)
4. Steel tape measure
5. Cross head screwdriver
6. Flat head screwdriver
7. Spirit level
8. Pencil
9. Adjustable spanner
10. Screws for fitting the stability bracket
11. 4 mm & 3 mm Allen keys
12. 13 mm spanner or socket wrench

Checking the Parts:

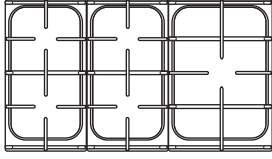
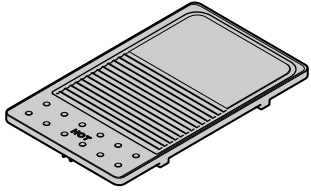
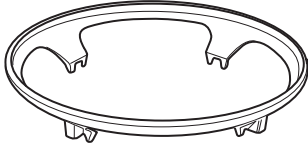
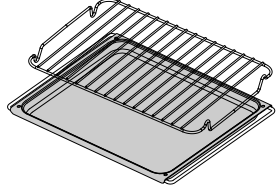
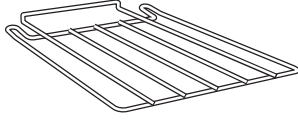
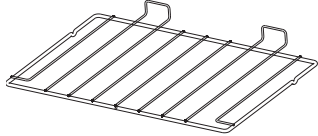
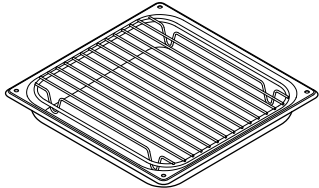
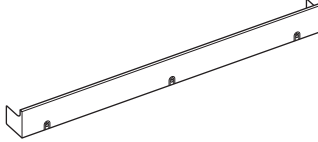
<i>3 pan supports</i> 	<i>Griddle</i> 
<i>Wok cradle</i> 	<i>Deluxe oven tray and trivet</i> 
<i>2 standard shelves</i> 	<i>2 flat shelves</i> 
<i>Grill pan</i> 	<i>Plinth</i> 

INSTALLATION

Check the appliance is electrically safe and gas sound when you have finished.

Positioning the Cooker

Fig. 8.1 and **Fig. 8.2** show the minimum recommended distance from the cooker to nearby surfaces.

The cooker should not be placed on a base.

Above hotplate surround should be level with, or above, any adjacent work surface.

A gap of 75 mm should be left between each side of the cooker **ABOVE** the hotplate level and any adjacent vertical surface.

For non-combustible surfaces (such as unpainted metal or ceramic tiles), this can be reduced to 25 mm.

A minimum space of 650 mm is required between the top of the hotplate and a horizontal combustible surface.

**Any cookerhood should be installed in accordance with the hood manufacturer's instructions.*

***Any splashback must be fitted in accordance with the manufacturers instructions. Allowance should be made for the additional height of the flue trim, which is fitted to the cooker hob.*

Surfaces of furniture and walls at the sides and rear of the appliance should be heat, splash and steam resistant. Certain types of vinyl or laminate kitchen furniture are particularly prone to heat damage and discolouration.

We cannot accept responsibility for damage caused by normal use of the cooker to any material that de-laminates or discolours at temperatures less than 65°C above room temperature.

We recommend a gap of 1010 mm between units to allow for moving the cooker. Do not box the cooker in – it must be possible to move the cooker in and out for cleaning and servicing.

Moving the Cooker

⚠ On no account try and move the cooker while it is plugged into the electricity supply.

⚠ The cooker is very heavy, so take great care.

We recommend that two people manoeuvre the cooker. Make sure that the floor covering is firmly fixed, or removed, to prevent it being disturbed when moving the cooker around.

To help you, there are two levelling rollers at the back, and two screw-down levelling feet at the front.

Remove the polystyrene base pack. From the front, tilt the cooker forward and remove the front half of the polystyrene base (**Fig. 8.3**). Repeat from the back and remove the rear half of the polystyrene base.

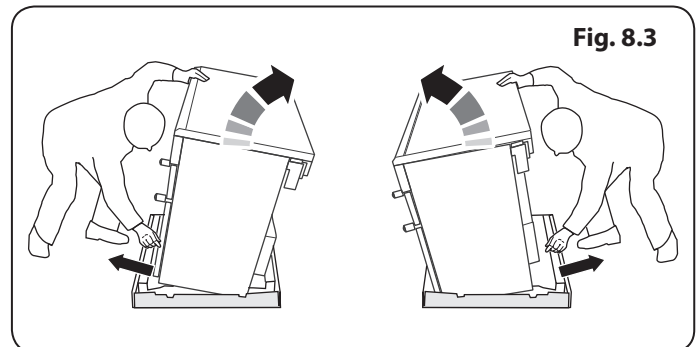
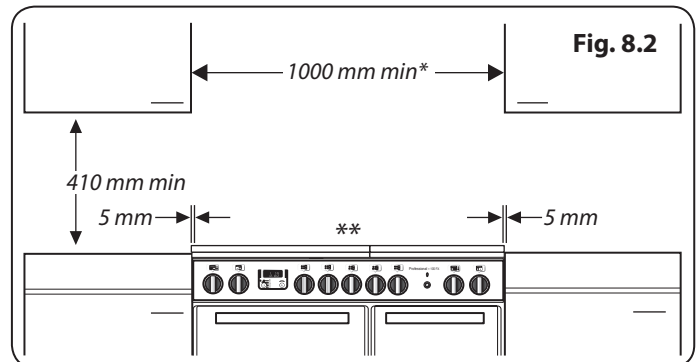
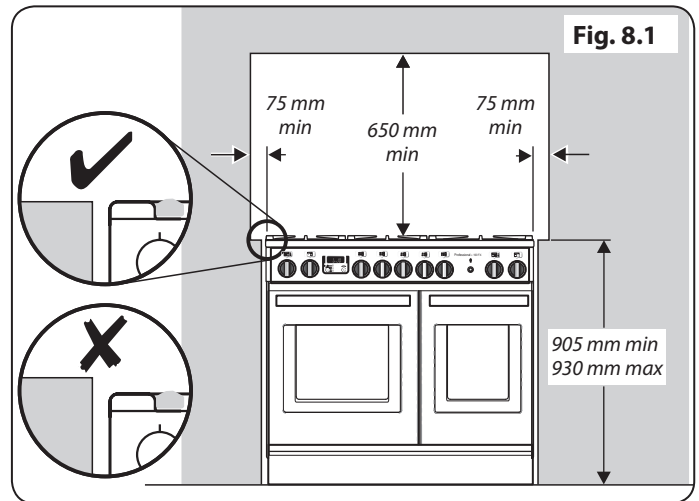

INSTALLATION

Check the appliance is electrically safe and gas sound when you have finished.

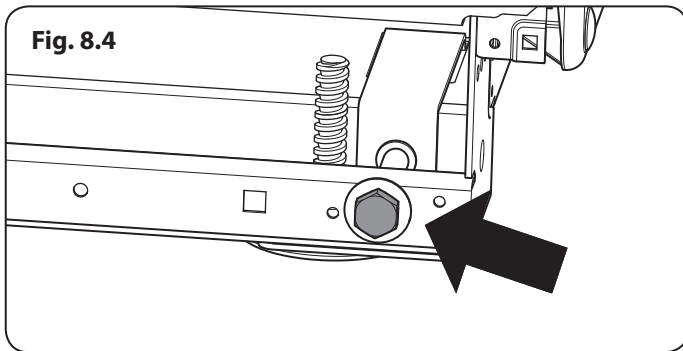

Lowering the Two Rear Rollers

To adjust the height of the rear of the cooker, first fit a 13 mm spanner or socket wrench onto the hexagonal adjusting nut (**Fig. 8.4**). Rotate the nut – clockwise to raise – counter-clockwise to lower.

Make 10 complete (360°) turns clockwise.

Make sure you lower BOTH REAR ROLLERS.

Completing the Move

Unfold the rear edge of the pack base tray.

We recommend that you remove the oven doors to move the cooker. Open the oven door fully and place the supplied holding pins in the drop down hinges (**Fig. 8.5**).

Carefully lift the door panel up and out, place safely to one side. You can now get a good grip from inside of the oven (not the fascia panel) as you move the oven (**Fig. 8.6**).

Carefully push the cooker backwards off the cardboard base. Remove the pack base tray.

Position the cooker close to its final position, leaving just enough space to get behind it.

After moving, carefully refit the door panel and push down gently to release the holding pins.

⚠ Do not use the door handles or control knobs to manoeuvre the cooker.

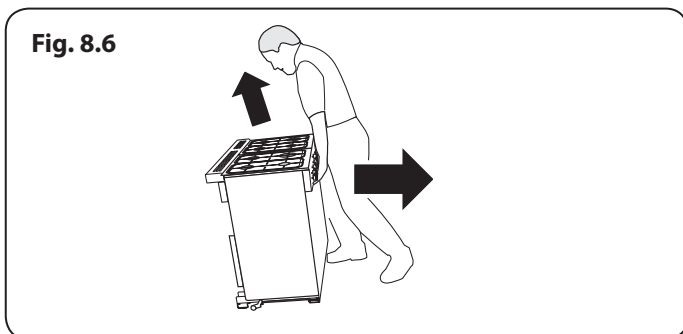
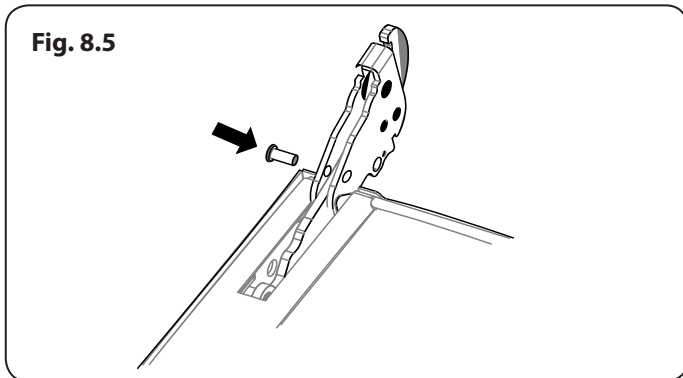

Fitting the Stability Bracket or Chain

Unless otherwise stated, a cooker using a flexible gas connector must be secured with a suitable stability device.

Suitable stability devices are shown in **Fig. 8.7**, **Fig. 8.8** and **Fig. 8.9**.

If you are using a stability chain (**Fig. 8.7**) then the chain should be kept as short as is practicable and fixed firmly to the rear of the cooker.

If you are using a stability bracket (**Fig. 8.8** and **Fig. 8.9**), then adjust the bracket to give the smallest practicable clearance between the bracket and the engagement slot in the rear of the cooker.

Fit the bracket so that it engages as far as possible over the chassis of the cooker.

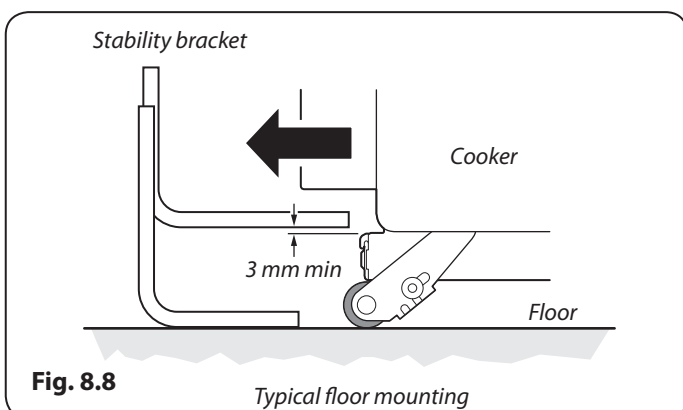
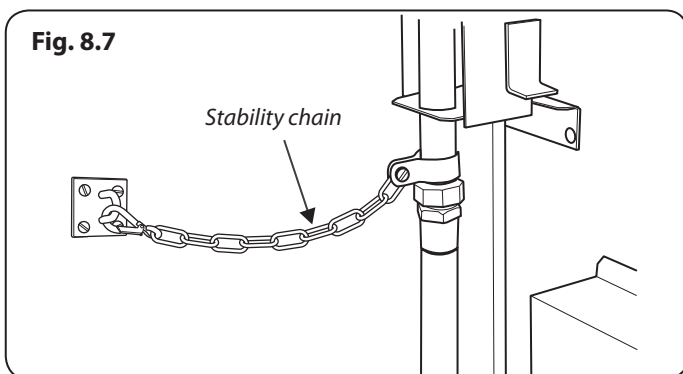

INSTALLATION

Check the appliance is electrically safe and gas sound when you have finished.

Conversion to Another Gas

If the appliance is to be converted to another gas do the conversion at this point. See the conversion section of these instructions.

Levelling

You are recommended to use a spirit level on a shelf in one of the ovens to check for level.

Place the cooker in its intended position, taking care not to twist it within the gap between the kitchen units as damage may occur to the cooker or the units.

The front feet and rear rollers can be adjusted to level the cooker.

To adjust the height of the rear of the cooker use a 13 mm spanner or socket wrench to turn the adjusting nuts at the front bottom corners of the cooker.

To set the front, turn the feet bases to raise or lower.

Gas Connection

This must be in accordance with the relevant standards.

The flexible hose (not supplied with the cooker) must be in accordance with the relevant standards. Hoses may be purchased at most builders' merchants.

We recommend that a Micropoint gas hose is used when installing this appliance.

The gas supply needs to terminate with a side-facing elbow with a down-facing bayonet.

The connector is located just below the hotplate level at the rear of the cooker. If in doubt contact your supplier.

The rear cover boxes limit the position of the supply point.

Because the height of the cooker can be adjusted and each connection is different, it is difficult to give precise dimensions.

Although a 900 mm hose can be used, a 1100 mm hose will allow slightly more flexibility in the positioning of the bayonet and make moving the cooker easier.

The hose should be fitted so that both inlet and outlet connections are vertical so that the hose hangs downwards in a 'U' shape.

Ideally the hose supply connection should be within the shaded area 'A' (Fig. 8.10).

For Natural Gas, the flexible hose must be in accordance with BS 669. For LP Gas, it should be capable of 50 mbar pressure, 70°C temperature rise, and carry a red stripe, band or label. If in doubt contact your supplier.

Screw connect the threaded end of the hose into the gas inlet. After completing the gas connection, make sure that the cooker is gas sound with a pressure test.

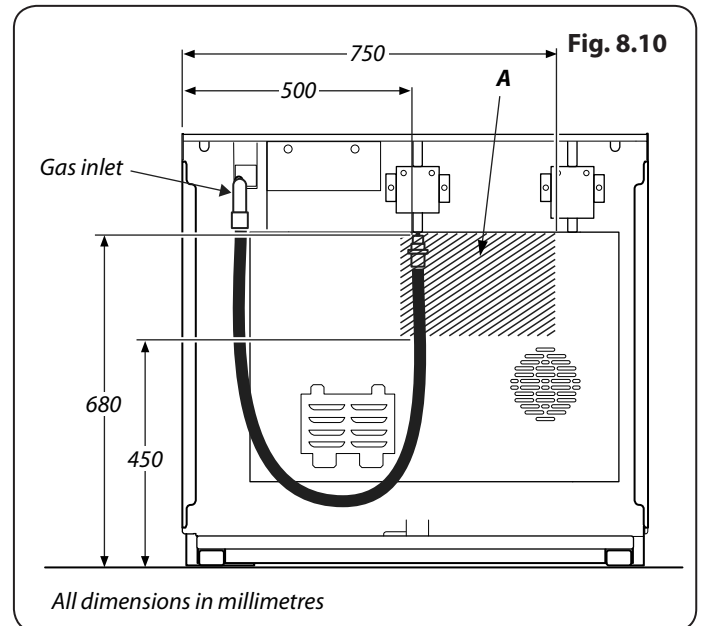
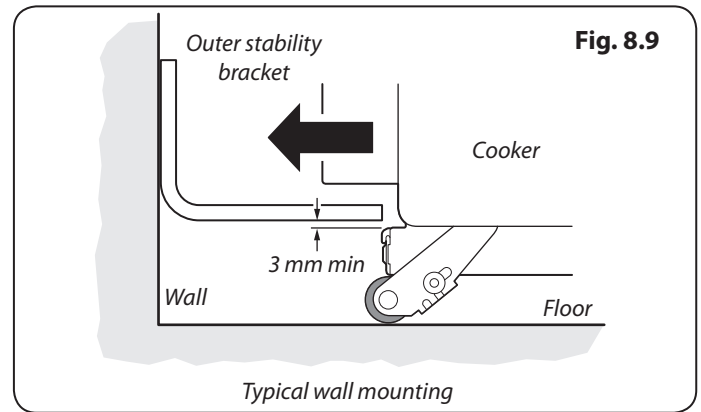

INSTALLATION

Check the appliance is electrically safe and gas sound when you have finished.

Current Operated Earth Leakage Breakers

The combined use of your cooker and other domestic appliances may cause nuisance tripping, so we recommend that the cooker is protected on an individual RCD (Residual Current Device) or RCBO (Residual Current Breaker with Overload).

IF IN DOUBT, PLEASE CONSULT A SUITABLY QUALIFIED ELECTRICIAN.

Fig. 8.11

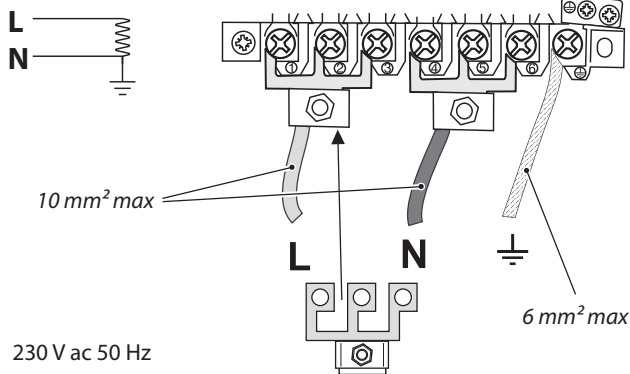

230 V ac 50 Hz

Fig. 8.12

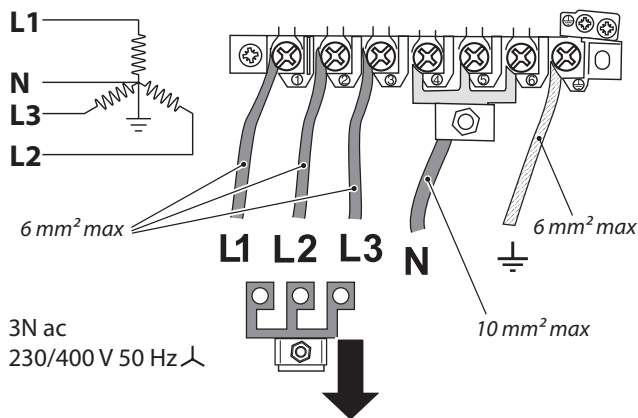

3N ac
230/400 V 50 Hz

Fig. 8.13

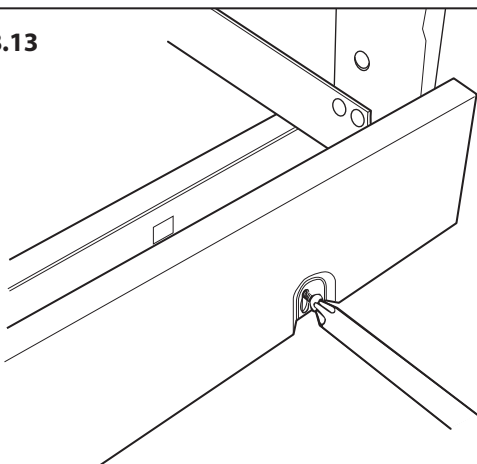

Pressure Testing

The gas pressure can be measured at one of the hotplate burner injectors (not the wok burner).

Lift off a burner head. Fit the pressure gauge to the injector. Turn on and light one of the other hotplate burners.

Turn on the control knob for the burner with the pressure gauge fitted to let gas through.

See the data badge for test pressures.

Turn off the burners. Make sure that you reassemble the burner top in the correct way on the burner body.

Electrical Connection

The cooker must be installed by a qualified electrician, in accordance with all relevant British Standards/Codes of Practice (in particular BS 7671), or with the relevant national and local regulations.

Note: The cooker must be connected to the correct electrical supply as stated on the voltage label on the cooker, through a suitable cooker control unit incorporating a double-pole switch, having a contact separation of at least 3 mm in all poles.

⚠ The cooker MUST NOT be connected to an ordinary domestic power point.

Access to the mains terminal is gained by removing the electrical terminal cover box on the back panel. Connect the mains cable to the correct terminals for your electrical supply type (**Fig. 8.11** and **Fig. 8.12**). Check that the links are correctly fitted and that the terminal screws are tight. Secure the mains cable using the cable clamp.

Final Checks

Hotplate Check

Check each burner in turn (refer to the 'Hotplate Burners' section at the front of the instructions).

Oven Check

Set the clock as described earlier in the instructions, and then turn on the ovens. Check that the oven fan starts to turn and that the ovens start to heat up.

Note: The oven light bulbs are not included in the guarantee.

Turn off the oven.

Fitting the Plinth

Loosen the three screws along the front bottom edge of the cooker. Hook the central keyhole over the central screw. Twist and fit each end keyhole over their respective screws. Tighten the fixing screws (**Fig. 8.13**).

Customer Care

Installer: Please complete your details in this guide, inform the user how to operate the cooker and hand over the instructions.

Thank you.

INSTALLATION

Check the appliance is electrically safe and gas sound when you have finished.

To fit the drawer

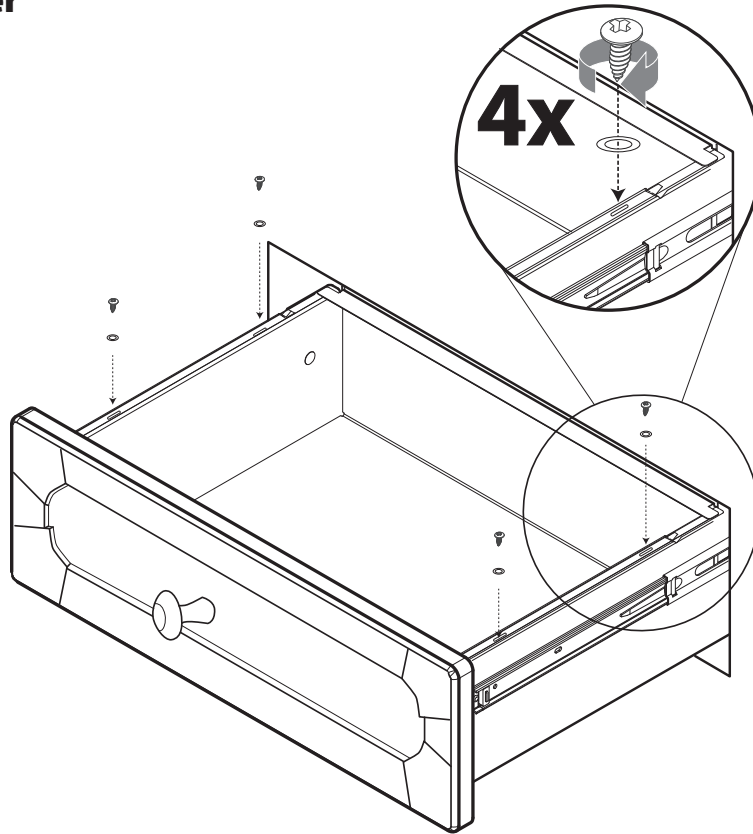

To remove the drawer

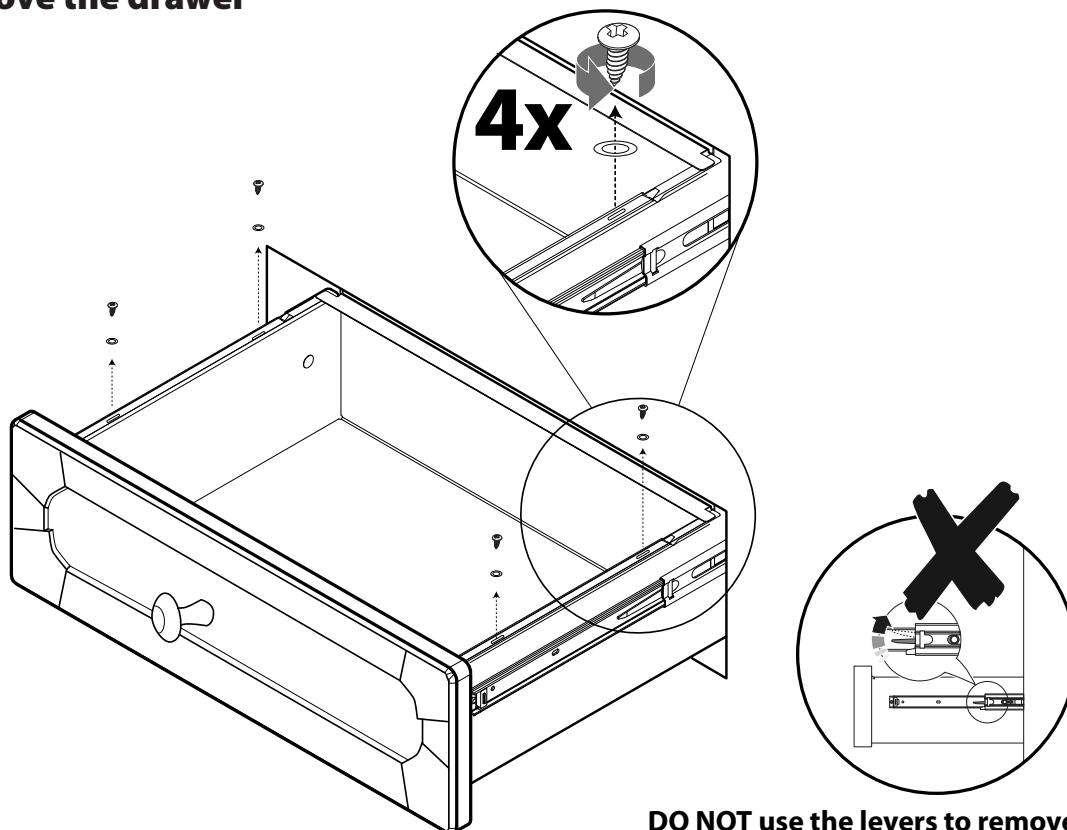

DO NOT use the levers to remove the drawer

9. Circuit Diagram

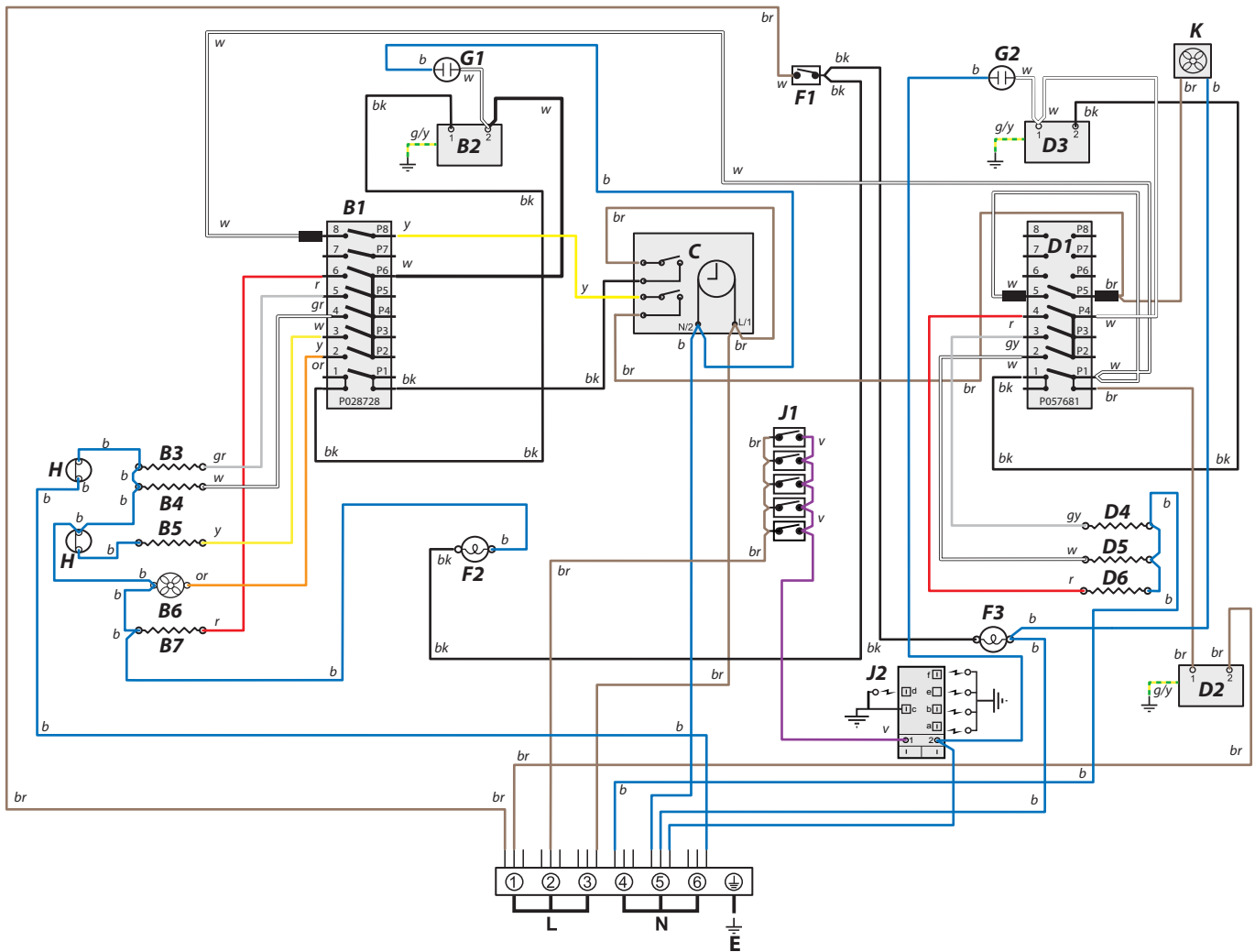

Key

The connections shown in the circuit diagram are for single-phase. The ratings are for 230V 50Hz.

Code	Description
B1	Left-hand oven multi-function switch
B2	Left-hand oven multi-function oven thermostat
B3	Multifunction oven top element (outer pr.)
B4	Multifunction oven top element (inner pr.)
B5	Multifunction oven base element
B5	Multifunction oven fan
B7	Multifunction oven fan element
C	Clock
D1	Right-hand oven multi-function switch
D2	Right-hand oven protection thermostat
D3	Right-hand oven temperature thermostat
D4	Right-hand oven top element (outer)

Code	Description
D5	Right-hand oven top element (inner)
D6	Right-hand oven base element
F1	Light switch
F2	Left-hand oven light
F3	Right-hand oven light
G1	Left-hand oven neon
G2	Right-hand oven neon
H	Left-hand oven thermal cut-out
J1	Gas ignition switch
J2	Spark generator
K	Cooling fan

Code	Colour
b	Blue
br	Brown
bk	Black
or	Orange
r	Red
v	Violet
w	White
y	Yellow
g/y	Green/yellow
gr	Grey

10. Technical Data

THE COOKER IS CATEGORY: CatII₂H3+.

It is supplied set for group H natural gas. A conversion kit from NG to LP is available for the cooker.

INSTALLER: Please leave these instructions with the user.

DATA BADGE LOCATION: Cooker back, serial number repeater badge below oven door opening.

COUNTRY OF DESTINATION: GB, IE.

Connections

Gas (Rp ½ at rear right-hand side)		Electric
Natural Gas	20 mbar	230/400V 50Hz
Butane	29 mbar	
Propane	37 mbar	

See the appliance badge for test pressures.

Dimensions

Model	Professional+ FX 100 Dual Fuel	
Overall height	minimum 905 mm	maximum 930 mm
Overall width	994 mm	
Overall depth	604 mm excluding handles, 642 mm including handles	
Minimum height above the hotplate	650 mm	

Hotplate Ratings

Hotplate	Bypass Screw*	Natural Gas 20 mb		L.P. Gas	
			Injector		Injector
Wok burner	57	3.5 kW	internal 78	3.5 kW (246 g/h)	internal 53
			external 126		external 82
Rapide/ Large Burner	40	3 kW	134	3.0 kW (210 g/h)	87
Semi Rapide / Medium Burner	32	1.7 kW	109	1.7 kW (119 g/h)	68
Auxiliary / Small Burner	28	1 kW	75	1.0 kW (70 g/h)	51

* The valves in this cooker are fitted with adjustable bypass screws. The cooker is supplied with the bypass screws set for Natural Gas. For LPG conversion the bypass screws must be screwed all the way down.

Hotplate energy saving tips

- Use cookware with a flat base.
- Use the correct size cookware.
- Use cookware with a lid.
- Minimise the amount of liquid or fat.
- When liquid starts boiling, reduce the setting.
- Consumption is based on G30.

Oven energy saving tips

- Cook meals together, if possible.
- Keep the pre-heating time short.
- Do not lengthen cooking time.
- Do not open the oven door during the cooking period.
- Do not forget to turn the appliance off at the end of cooking.

Hotplate Efficiency

Brand	Rangemaster
Model Identification	Professional+ FX
Size	100
Type	Dual Fuel
Type of Hob	GAS
Number of gas burners	5
Auxiliary / Small Burner (EE gas burner)	-
Semi Rapide / Medium Burner (EE gas burner)	58%
Semi Rapide / Medium Burner (EE gas burner)	58%
Rapide / Large Burner (EE gas burner)	56%
Rapide / Large Burner (EE gas burner)	-
Wok (EE gas burner)	53%
Wok (EE gas burner)	-
Hotplate EE gas hob (*)	56%

Information marked thus (*) is not required with mixed fuel hobs

Oven Data

Brand	Rangemaster	
Model identification	Professional+ FX	
Type of oven	Electric	
Mass	kg	114
Number of cavities	2	
Left-hand Efficiency		
Fuel type	Electric	
Cavity type *Drop Down Door	Multifunction (DDD)*	
Power - conventional	2.2	
Power - forced air convection	2.5	
Volume	Litres	75
Energy consumption (electricity) - conventional	kWh / cycle	1.08
Energy consumption (electricity) - forced air convection	kWh / cycle	0.91
Energy efficiency index - conventional	124.9	
Energy efficiency index - forced air convection	105.2	
Energy class	A	
Right-hand Efficiency		
Fuel type	Electric	
Cavity type *Drop Down Door	Multifunction (DDD)*	
Power - conventional	1.84	
Power - forced air convection	-	
Volume	Litres	53
Energy consumption (electricity) - conventional	kWh / cycle	0.86
Energy consumption (electricity) - forced air convection	kWh / cycle	-
Energy efficiency index - conventional	111.3	
Energy efficiency index - forced air convection	-	
Energy class	B	

Additional Information		
The oven complies with EN 60350-1		
Maximum output @ 230V 50Hz		
Conventional	2.2 kW	
Multifunction	2.5 kW	
Multifunction (with Rapid Response)	-	
Multifunction (Tall Oven)	1.84 kW	
Grill	-	
Slow Oven	-	
Bread Proving Drawer	-	

Maximum total electrical load at 230 V (approximate total including hob, oven lights, oven fan, etc.):	4.44 kW
---	---------

Note

Note

Note

Name of Appliance & Colour*				
Appliance Serial Number*				
Fuel Type*	Natural Gas	<input type="checkbox"/>	LP Gas	<input type="checkbox"/>
	Dual Fuel	<input type="checkbox"/>	Electric	<input type="checkbox"/>
Retailer's Name & Address				
Date of Purchase				
Installer's Name & Address				
Installer's Telephone Number				
Date of Installation				

*This information is on the appliance data badge - look in the appliance instructions to find out where the data badge is located.

CONSUMER SERVICE

If you have any product enquiries, or in the event of a problem with your appliance once it has been installed, please telephone 0800 804 6261 or 0370 789 5107 from a mobile.

CONSUMER SERVICE LINES OPEN:

Monday to Thursday 8am-6pm
 Friday 8am-5pm
 Saturday 9am-1pm

WARRANTY

Your manufacturer warranty covers goods of our own brand for defective workmanship and materials for a period of 1 year from the date of purchase. This warranty covers mechanical breakdown and proven cosmetic and manufacturing defects.

You will receive an additional FREE full 12 months guarantee by registering your purchase using the FREEPOST form provided. Alternatively, call free on 0800 587 5747, quoting reference RMGX57A, or register online at www.rangemaster.co.uk.

Any damage, blemishes or chips identified upon receipt of the product must be reported within 90 days - proof of purchase may be required to establish validity. Scratches on the surface of ceramic hobs must be reported within 14 days. Scratches caused by usage are not covered. Accidental damage is not covered by the manufacturer's warranty.

For warranty compliance, the requirements are that the appliance:

- Has been correctly installed in accordance with current legislation, relevant British and European Standards and Codes of Practice, by a suitably competent person registered with Gas Safe or equivalent body and, where applicable, a qualified electrician.
- Has been used solely for domestic cooking purposes.
- If in use in the UK*, has not been taken abroad as a personal export. (In the Republic of Ireland conditions may vary, so consult your retailer.)
- Is not second-hand or a refurbished appliance. The manufacturer's warranty is not transferable.
- Has not been subject to misuse, accidental damage or modification, and has not deteriorated due to normal domestic wear and tear, and the manufacturer's recommendations concerning cleaning materials have been followed.
- Has not been repaired by persons or organisations other than those authorised to act on behalf of AGA Rangemaster.

Exceptions:

- Items not included under the free 1 year guarantee include pan supports, griddles, wok rings, baking trays, grill pans, trivets, filters, light bulbs and other consumable accessories.
- Any damage caused other than through normal use.
- Breakdowns associated with cooking spillage.
- Cosmetic deterioration deemed to be normal wear and tear.

This warranty is in addition to your Statutory Rights.

* Only certain models can be adapted for use with Mains Gas supplied in the Channel Islands and Isle of Man.

OUT OF WARRANTY

We recommend that Rangemaster appliances are serviced regularly throughout their life to maintain optimum performance and efficiency. Service work should only be carried out by technically competent and suitably qualified personnel.

For your own safety, always make sure that work is carried out by a Gas Safe registered engineer for gas appliances or an approved electrician for electrical models.

For a competitive quote and to arrange for a Rangemaster approved engineer to attend, call Consumer Services on: 0800 804 6261 or 0370 789 5107 from a mobile.

SPARE PARTS

To maintain optimum and safe performance, we recommend that only genuine Rangemaster spare parts are used. These are available from most major spares stockists, including ourselves.

Contact Consumer Services on 0800 804 6261 or 0370 789 5107 from a mobile, who will be happy to help.

STANDARDS

Rangemaster cookers are designed and manufactured to a recognised international quality standard, which meets the requirements of BS EN ISO 9001, BS EN ISO 14001 and OHSAS 18001 for continually improving environmental procedures.

Rangemaster cookers comply with the essential requirements of the appropriate European Directives, and carry the CE mark.

Designed to impress
The Co-ordinating Collection.

• Refrigeration • Sinks & Taps • Hoods & Splashbacks • Built-in Cooking • Dishwashing



Built from experience

Clarence Street
Royal Leamington Spa
Warwickshire
CV31 2AD
England

Consumer Services: +44 (0)800 804 6261 or (0)370 789 5107 from a mobile.

Fax: +44 (0)1926 450526

E-mail: consumers@agarangemaster.co.uk

www.rangemaster.co.uk

For UK Trade Enquiries Tel: +44 (0)115 946 4000

Fax: +44 (0)115 973 6602

E-mail: sales@agarangemaster.co.uk

For ROI Enquiries Tel: 1850 302 502

Rangemaster is a trading name of AGA Rangemaster Limited

Registered in England and Wales. Registration No. 354715

Registered Office: Juno Drive, Leamington Spa, Warwickshire, CV31 3RG

AGA RANGEmaster



Rangemaster continuously seeks improvements in specification, design and production of products and thus, alterations take place periodically. Whilst every effort is made to produce up-to-date literature, this brochure should not be regarded as an infallible guide to current specification, nor does it constitute an offer for the sale of any particular appliance.

