

# BOCKSEY

Storage unit

Rangement

Ordenación

Aufraümmöbel

90 x 45 x 45 cm - 965 099 - 965 119 - 965 175 - 965 165

90 x 46,5 x 45 cm - 965 108 - 965 131 - 965 179 - 965 178 - 902 196 - 902 200

90 x 47 x 45 cm - 965 109 - 965 150 - 965 182 - 965 180 - 902 197 - 902 201

BOCK-LU-AW10-B

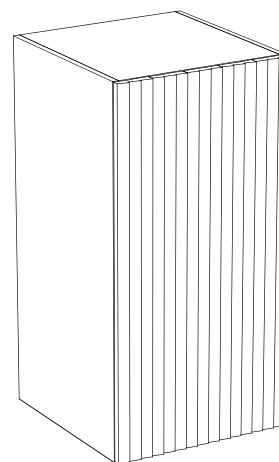
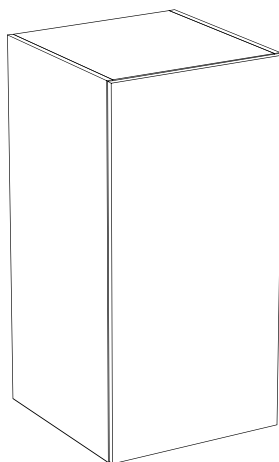
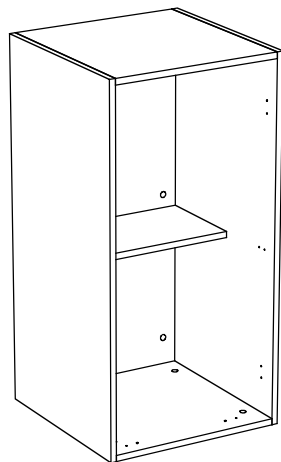
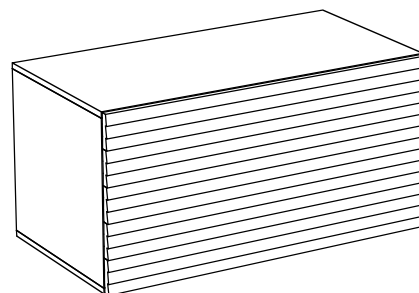
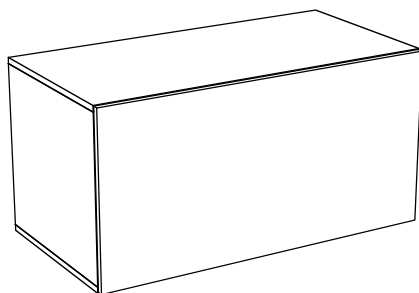
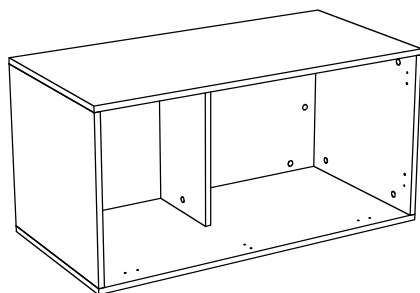
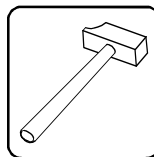
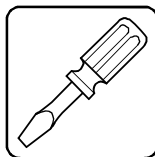
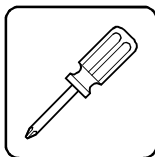
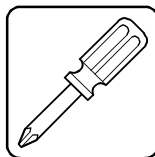
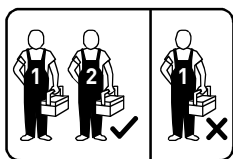

habitat 

# Components / Composants / Componentes / Bestandteile

Ref.: 965 099 - 965 119 - 965 175 - 965 165

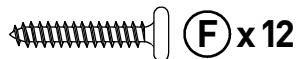
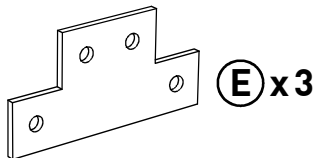
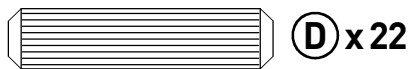
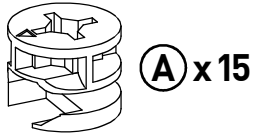
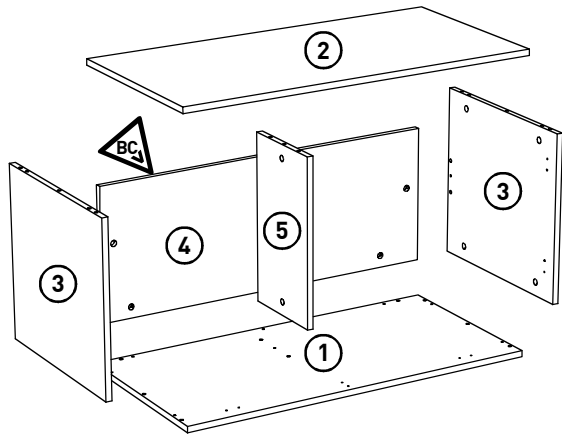

Retain batch code label.  
Préserver l'étiquette indiquant le code du lot.  
Guardar la etiqueta del código de lote.  
Etikett mit Chargen-Nummer bitte aufbewahren.

Ref.: 965 108 - 965 131  
965 179 - 965 178  
902 196 - 902 200

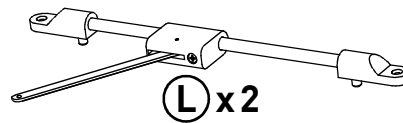
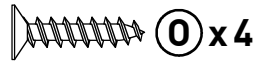
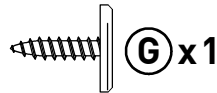
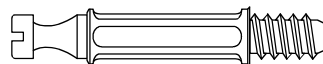
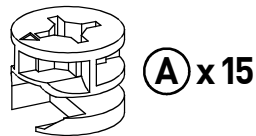
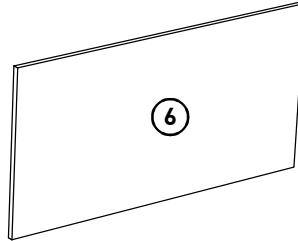

Ref.: 965 109 - 965 150  
965 182 - 965 180  
902 197 - 902 201

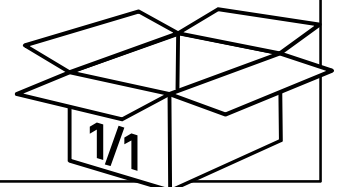
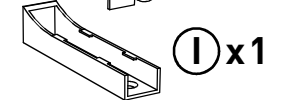
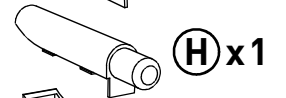
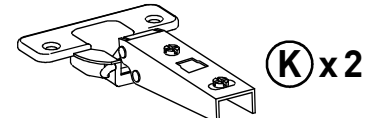
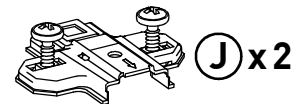
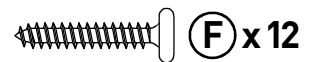
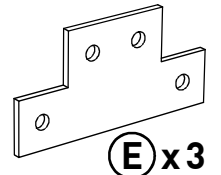
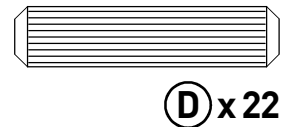
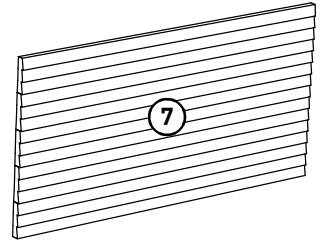

French legislation / Législation française / Legislazione francese / Französische Gesetzgebung

Structure en panneaux de particules plaqués chêne, érable ou noyer ou laqué rouge tomate, anthracite ou blanc. Porte à lattes en chêne, érable ou noyer massif ou en MDF laqué rouge tomate, anthracite ou blanc. Porte pleine en panneaux de particules plaqués chêne, érable ou noyer ou laqué rouge tomate, anthracite ou blanc.

Plan to assemble the furniture as near as possible to the place you intend it to be used.  
 Do not place your furniture directly in front of radiators, fires, or any source of direct heat.  
 Ensure that the surface on which you are assembling furniture is clean and flat.  
 Before commencing assembly, please identify all components.  
 Do not discard the packaging until the unit is fully assembled to ensure that no fittings or components are disposed of.

Ensamblar el mueble lo mas cerca posible del lugar donde lo quiere instalar.  
 No colocar los muebles directamente delante de un radiador o de otra fuente de calor vivo.  
 Asegurese que la superficie sobre la cual efectua el montaje este limpia y sea plana.  
 Antes de iniciar el montaje, identifique todos los componentes con ayuda de la nota.  
 Para no perder los componentes, no tirar el embalaje antes de haber terminado el montaje completo.

Planifiez d'assembler le meuble aussi près que possible de l'endroit où vous voulez l'installer.  
 Ne pas placer les meubles directement devant un radiateur ou une autre source de chaleur vive.  
 Assurez-vous que la surface sur laquelle vous effectuez le montage soit propre et plane.  
 Avant de débiter le montage, identifiez tous les composants à l'aide de la notice.  
 Afin de ne pas égarer de composants, ne jetez pas l'emballage avant d'avoir terminé le montage complet.

Bauen Sie das Möbelstück in der Nähe seines künftigen Standortes zusammen. Die Möbelstücke nicht direkt vor einem Heizkörper oder einer anderen Wärmequelle aufstellen.  
 Vergewissern Sie sich, dass die Fläche, auf der Sie den Zusammenbau vornehmen, eben und sauber ist.  
 Überprüfen Sie vor dem Zusammenbau, ob alle Schrankteile gemäß Montageanleitung vorhanden sind.  
 Damit keine Bauteile verloren gehen, sollten Sie die Verpackung erst nach dem Zusammenbau wegwerfen.

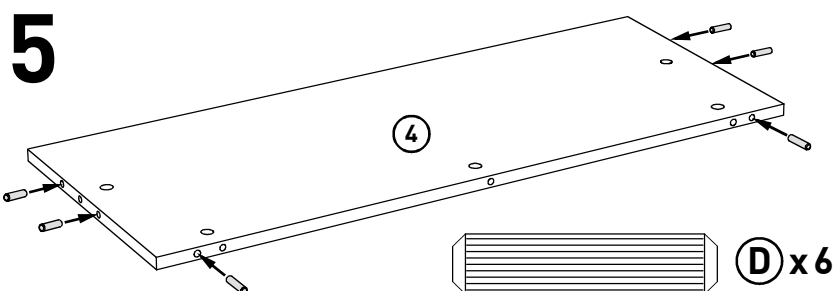
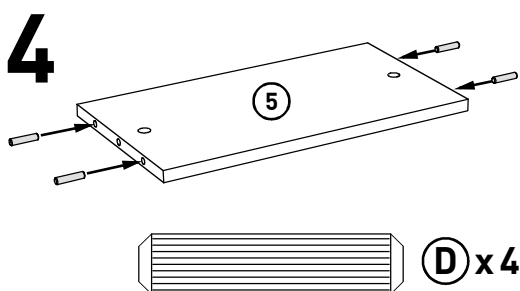
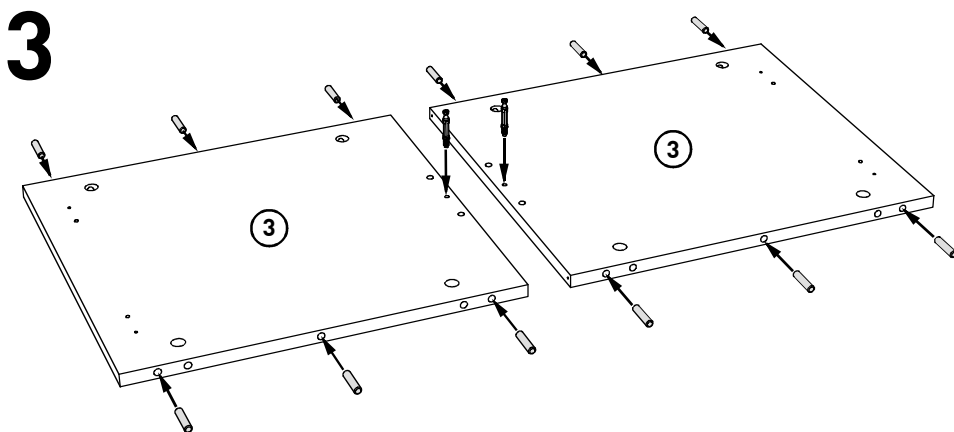
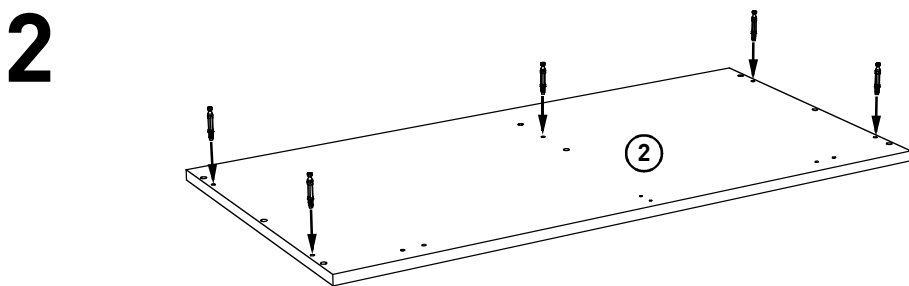
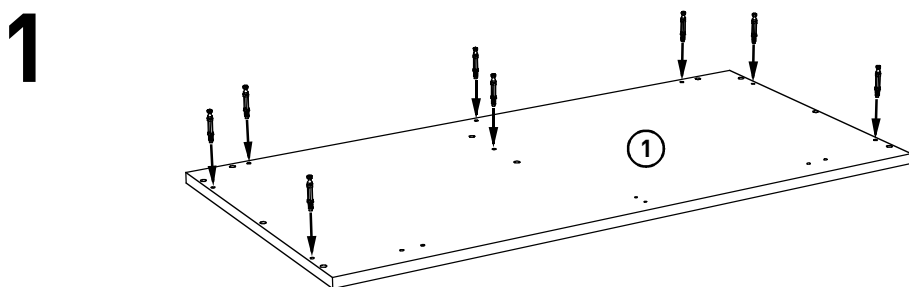

6

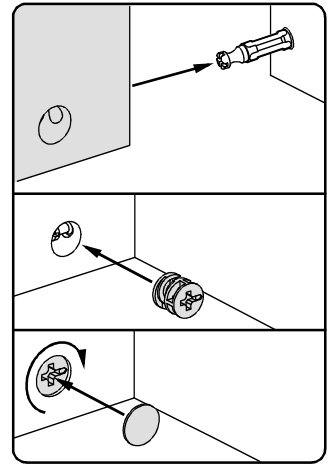
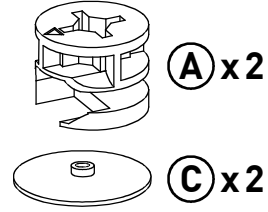
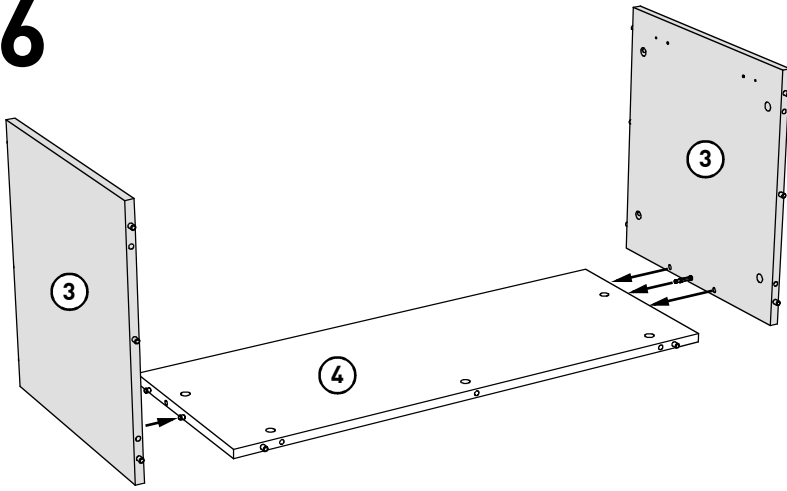

7

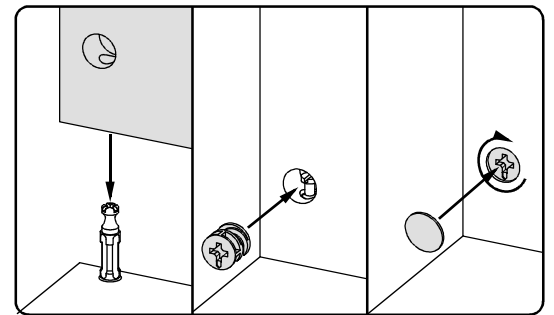
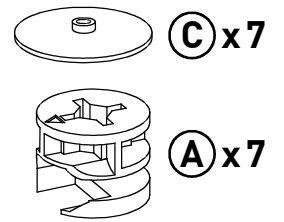
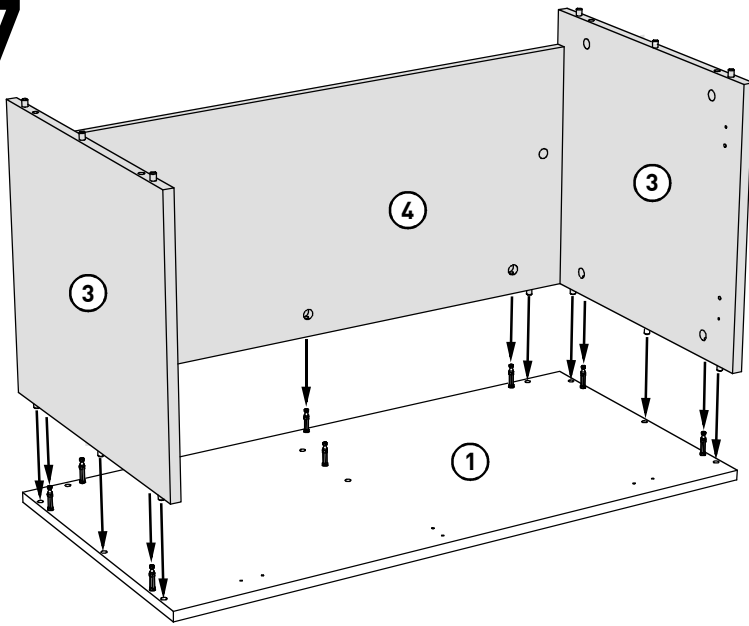

8

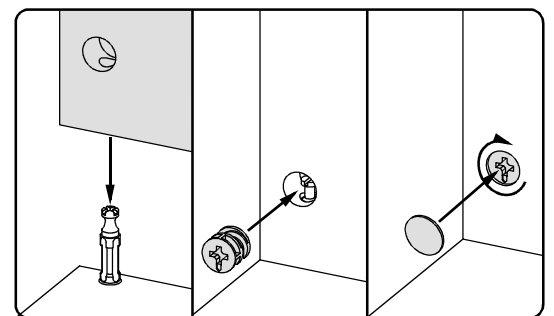
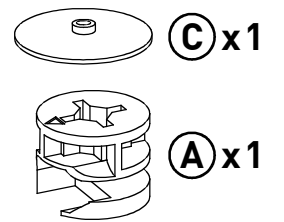
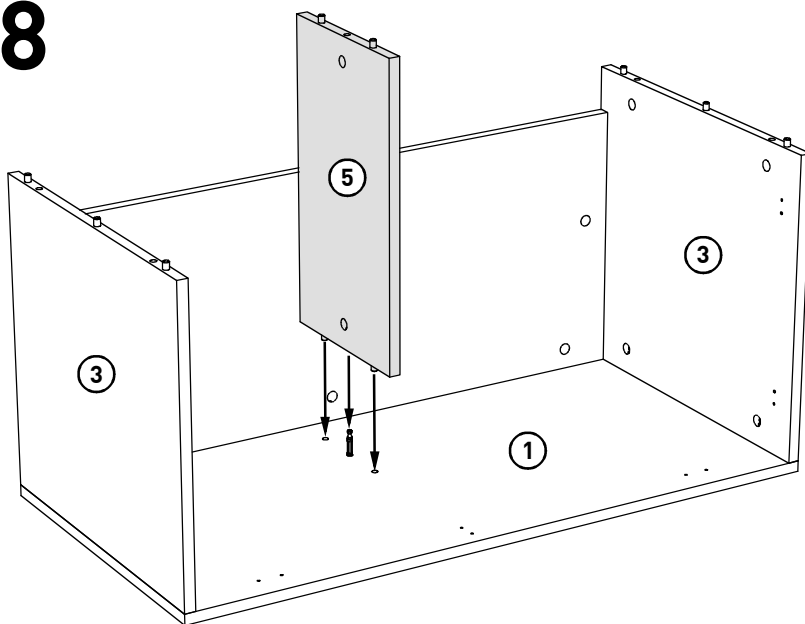

9

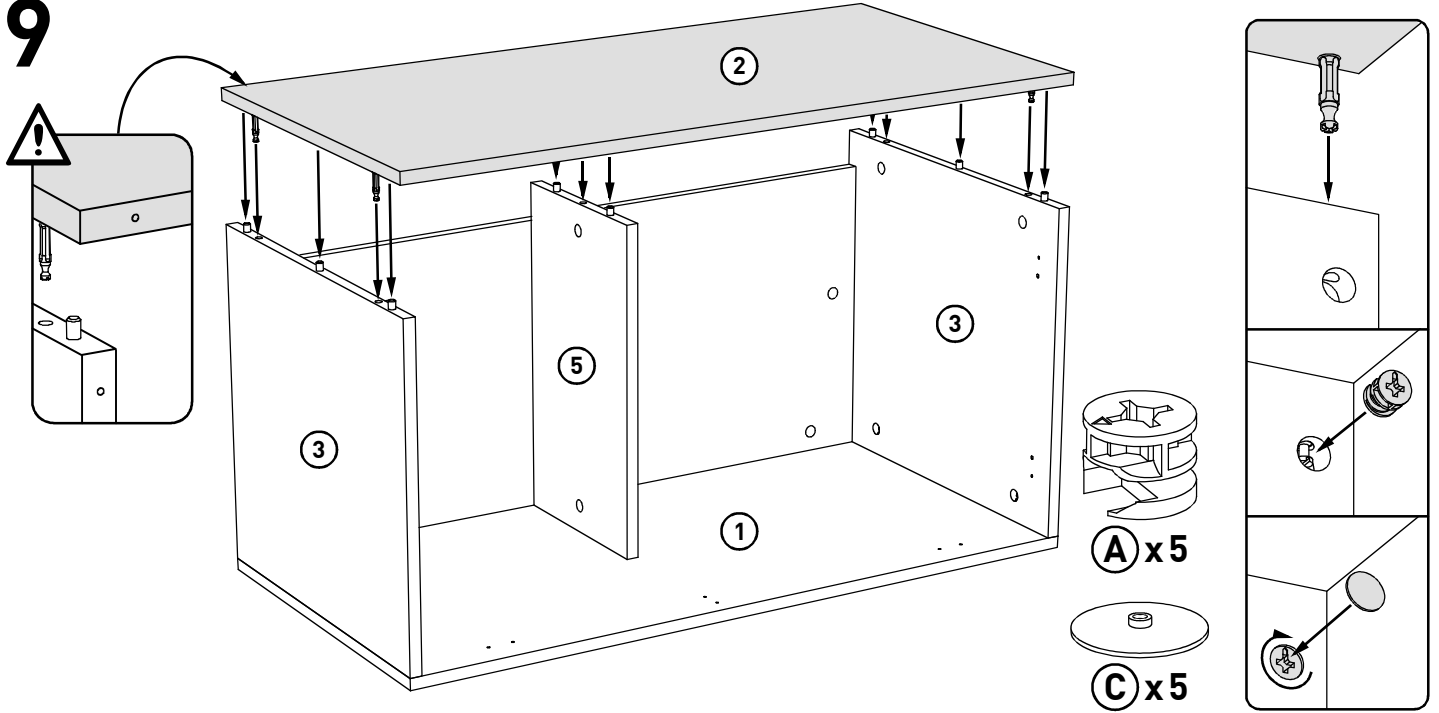

10a

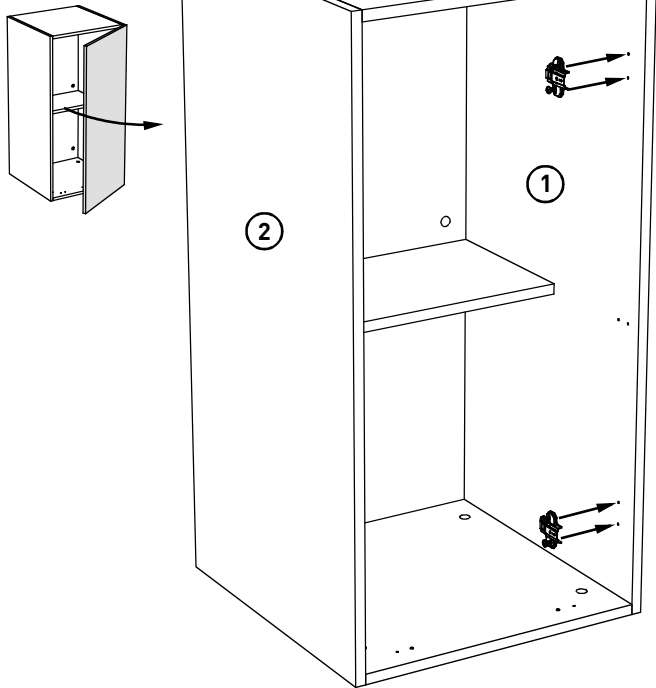

10b

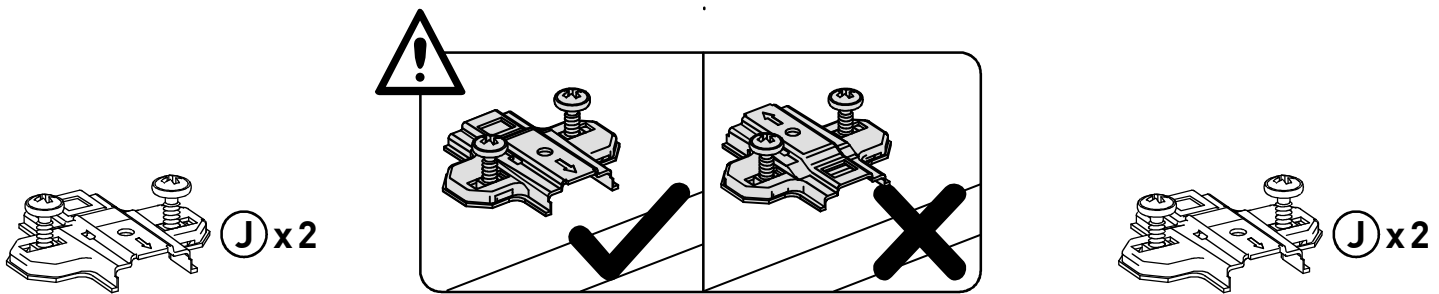
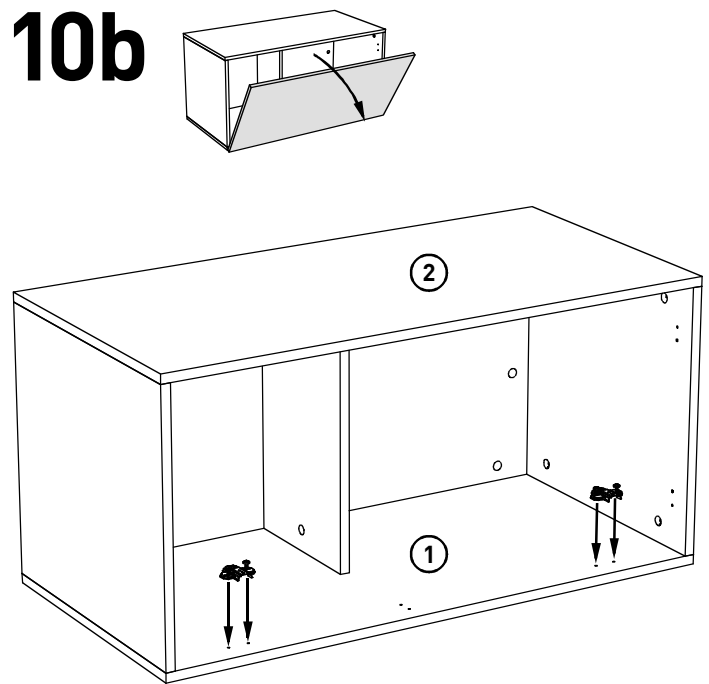

# 11a

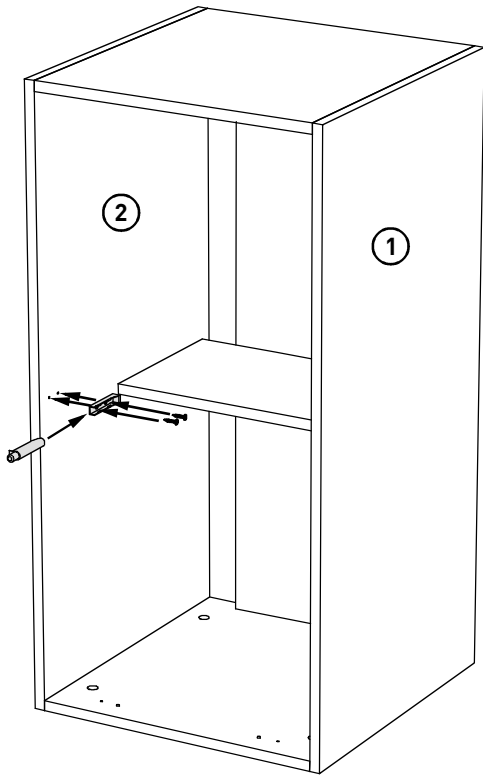
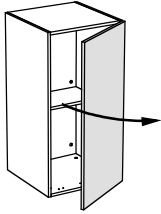

# 11b

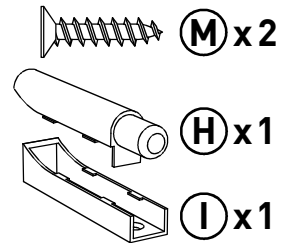
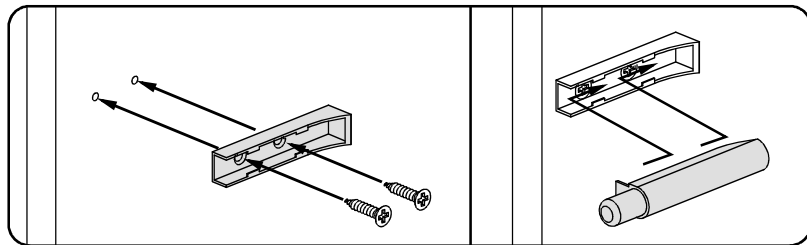
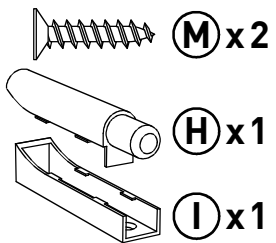
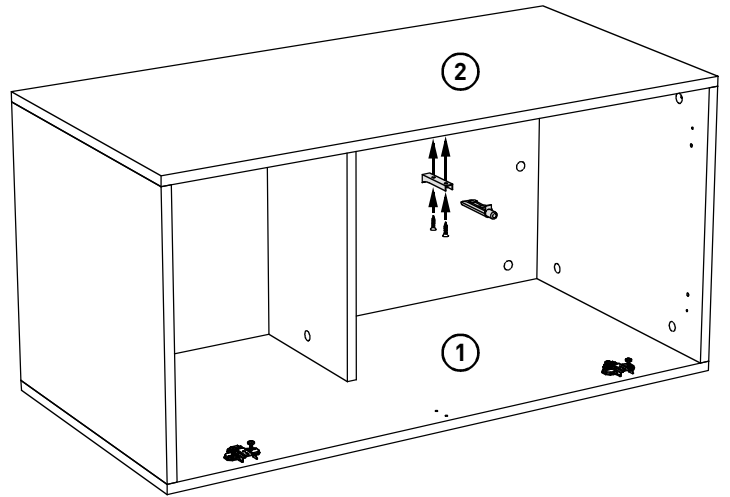
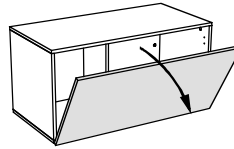

# 12

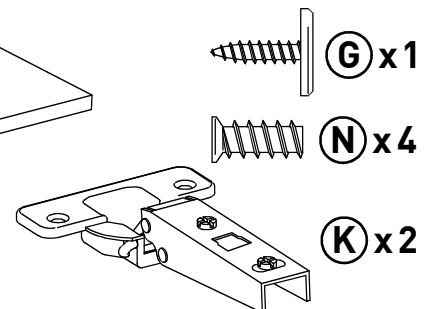
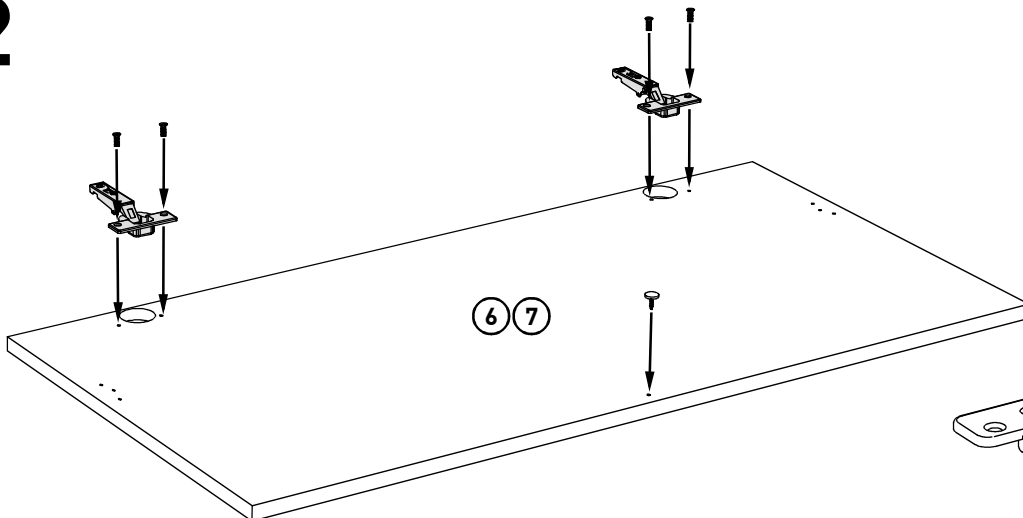

# 13a

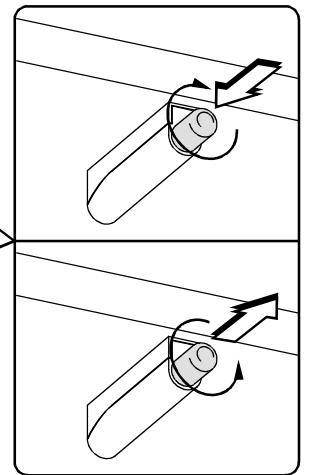
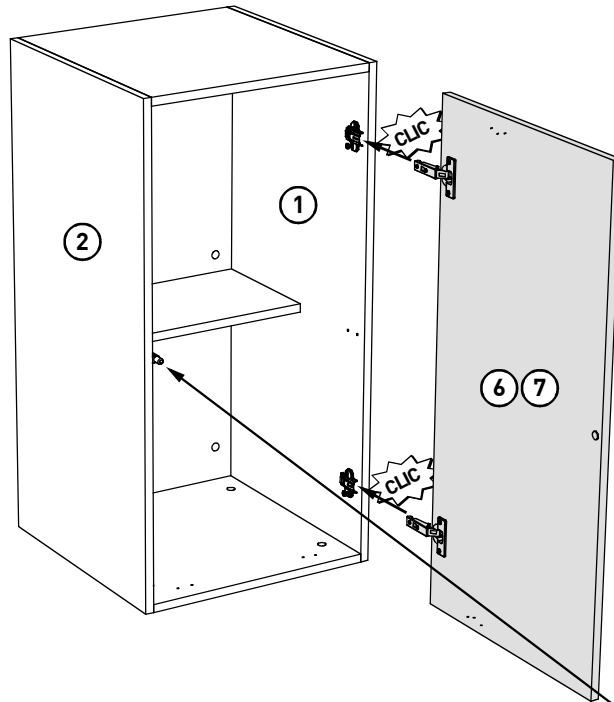
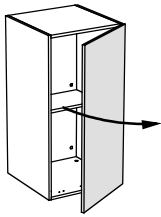

# 13b

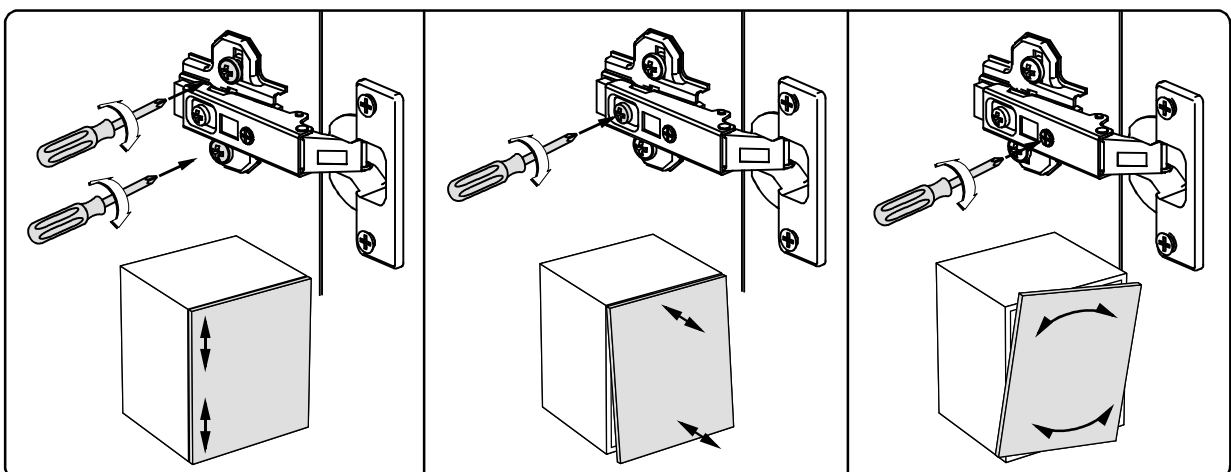
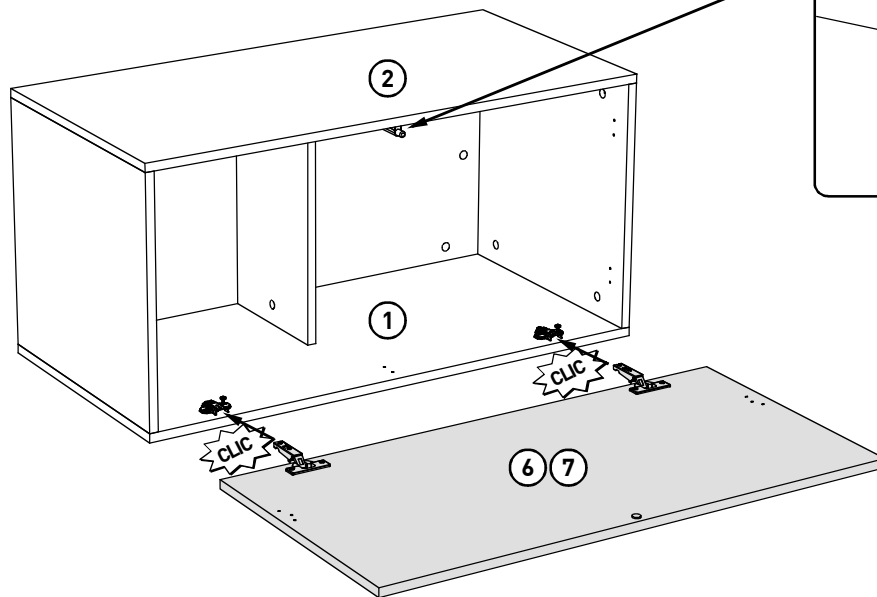
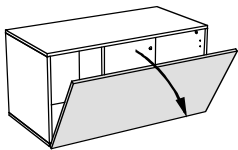

# 14

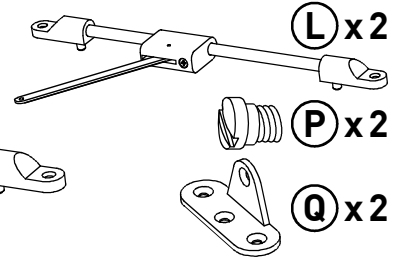
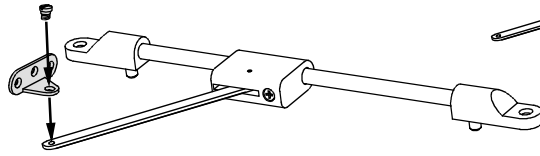
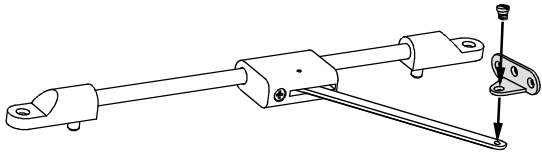

# 15

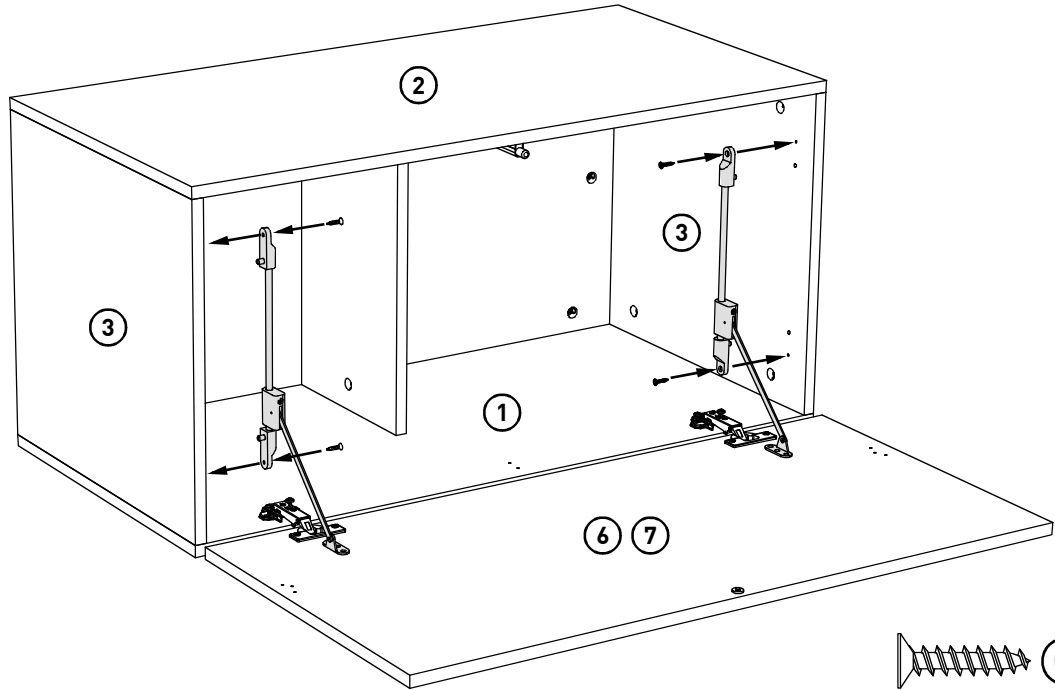
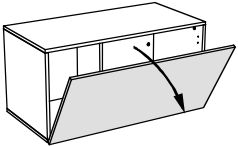

# 16

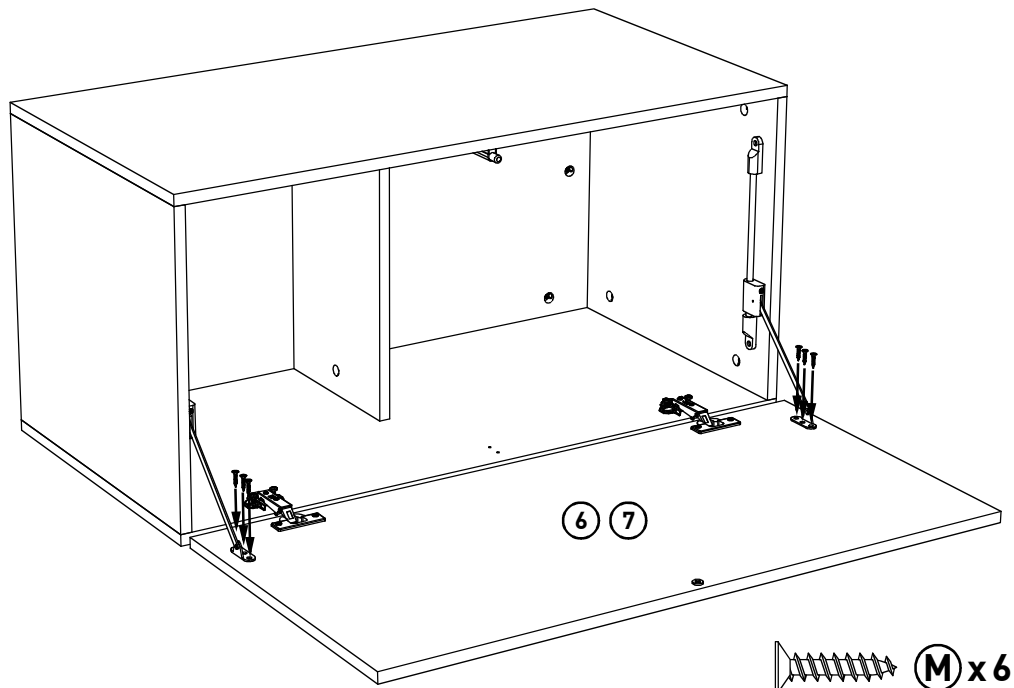
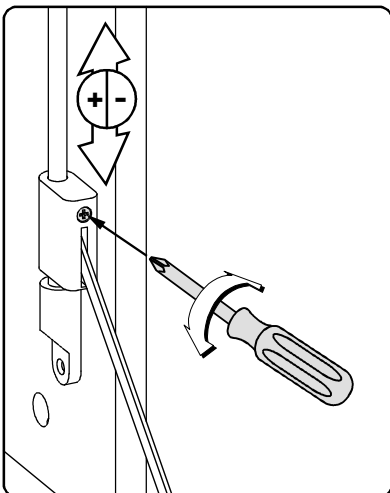
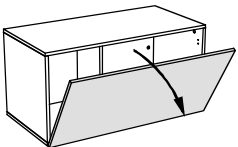



# 17a

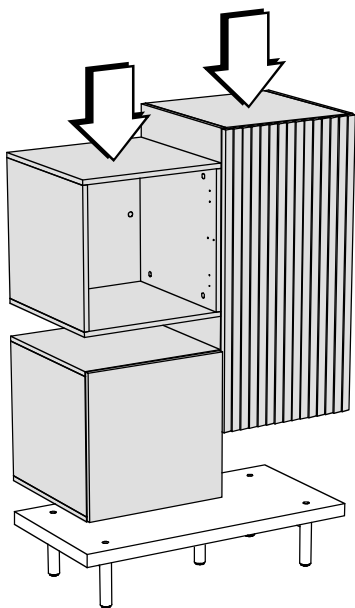

# 18a

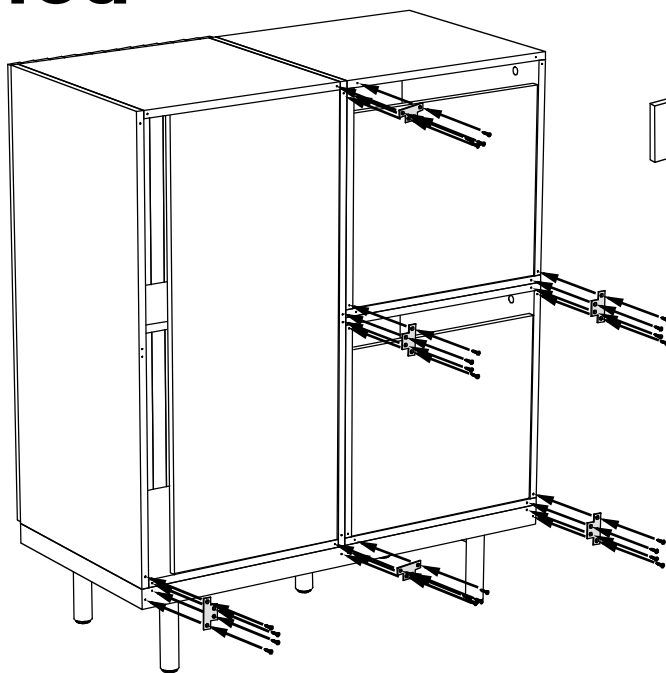

 **F** x4 (xN)

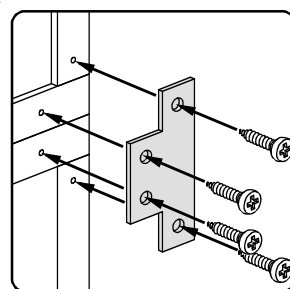
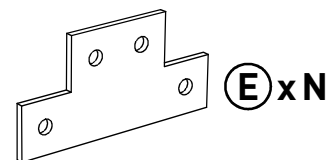

# 17b

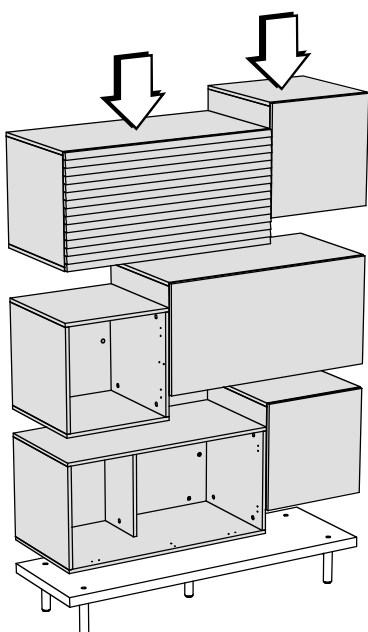

# 18b

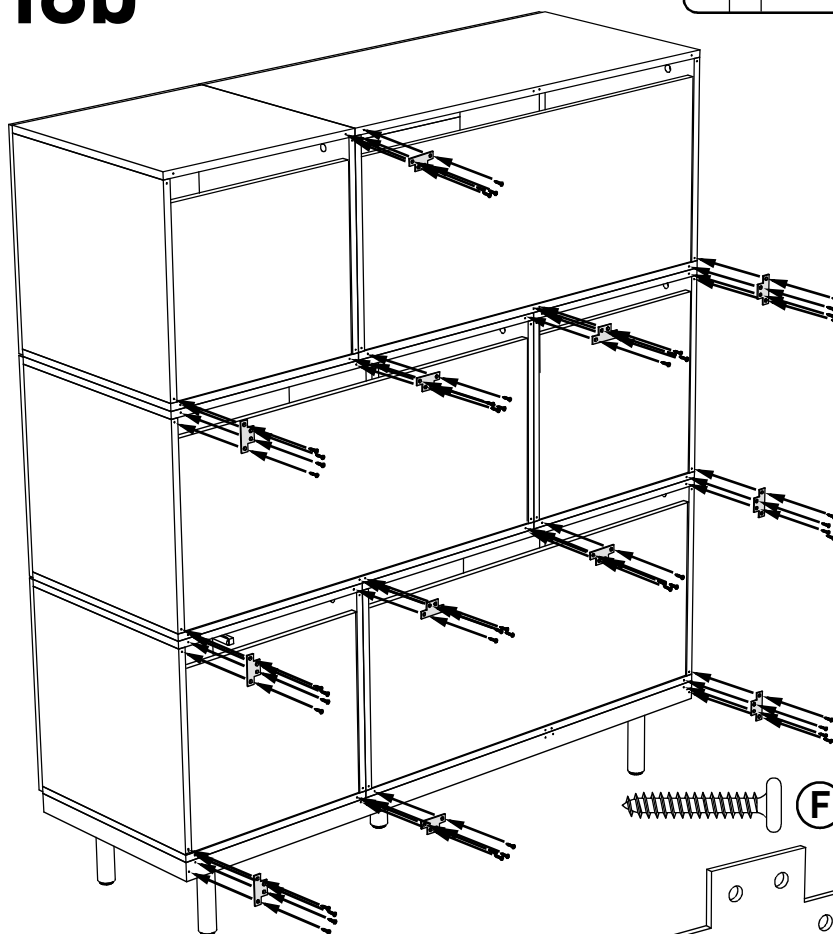

 **F** x4 (xN)

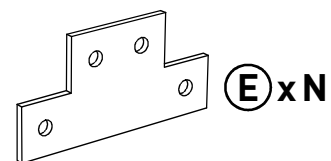

# CARE INSTRUCTIONS / ENTRETIEN / COSEJOS DE MANTENIMIENTO / PFLEGEHINWEISE

## Cleaning of Solid Timber / Veneers and Lacquered Surfaces.

Any spillage should be removed immediately by using a damp cloth, then wiping dry the surface with a clean dry duster. Repeat this procedure for periodic cleaning. The use of furniture polishes or sprays is not necessary or recommended.

## Cleaning of Melamine, Laminate, Linoleum and Metal Surfaces.

Regular dusting with a dry cloth will keep your units clean. However, to remove stubborn stains, wipe over with a damp cloth and washing up liquid. To clean chrome, stainless steel or glass surface, we recommend the use of proprietary cleaners. Always follow the cleaning fluid instructions carefully

If you have any comments or suggestions regarding this product, assembly instructions or service received, please enquire at your nearest store or contact us on our website at: [www.habitat.net](http://www.habitat.net) or write to this address:

HABITAT UK 42-46 PRINCELET STREET LONDON E15LP U.K.

## Nettoyage de bois massif où placage et surfaces laquées.

Les liquides renversés doivent être épongés immédiatement à l'aide d'un chiffon. Ensuite essuyer la surface à l'aide d'un chiffon propre et sec. L'emploi de produits spéciaux pour meubles n'est pas recommandé ni même nécessaire.

## Nettoyage des mélaminés, stratifiés, linoléum et surfaces métalliques.

Dépoussiérez régulièrement avec un chiffon sec. Pour les tâches rebelles utilisez un produit vaisselle liquide. Pour nettoyez les chromes, acier inoxydable où les glaces, utilisez les produits appropriés

Si vous avez des commentaires ou suggestions quelconques à faire au sujet de ce produit, sur les instructions de montage ou nos services, veuillez vous adresser à votre point de vente le plus proche ou nous contacter sur notre site Web : [www.habitat.net](http://www.habitat.net) ou nous écrire à l'adresse suivante :

HABITAT FRANCE - 33, Avenue de WAGRAM - 75 017 PARIS - FRANCE

## Limpieza de la madera maciza o contrachapada y de la superficies lacadas.

Los líquidos derramados se deben enjuagar inmediatamente con un trapo. Limpiar enseguida la superficie con un trapo limpio y seco. No se recomienda ni es necesario el uso de productos especiales para muebles.

## Limpieza de superficies de melamina, estratificadas, linóleo o metálicas.

Limpe el polvo regularmente con un trapo seco. Para las manchas rebeldes utilice un producto para limpieza de vajilla liquido. Si por cualquier motivo tuviera algún problema con su producto Habitat, póngase en contacto con la tienda donde lo compró.

Si desea hacernos algún comentario o sugerencia acerca de este producto, sus instrucciones de montaje o la calidad del servicio recibido, pregunte en su tienda Habitat más cercana o póngase en contacto con nosotros a través de nuestro sitio web, [www.habitat.net](http://www.habitat.net), o escribanos a la siguiente dirección:  
HABITAT S.A. - C/Tuset, 20-24. 4º8, - 08006 BARCELONA - SPAIN

## Reinigung von massiven Hölzern, Furnieren und lackierten Flächen.

Verschüttete Flüssigkeiten müssen sofort mit einem Tuch aufgewischt werden. Danach mit einem trockenen und sauberen Tuch nachwischen. Diesen Vorgang bei regelmäßige Reinigung wiederholen. Die Verwendung eines Spezialreinigers für Möbel ist nicht ratsam und nicht erforderlich.

## Reinigung von beschichteten und metallischen Flächen, sowie Linoleum-, und Melaminharzflächen.

Regelmäßig mit einem trockenen Tuch Staub wischen. Bei hartnäckigen Flecken etwas flüssiges Spülmittel verwenden. Zum Reinigen von Chrom, rostfreiem Stahl oder Spiegeln Spezialreiniger benutzen. Falls Sie Probleme mit Ihrem Habitat-Produkt haben sollten, wenden Sie sich bitte an das Geschäft, in dem Sie das Produkt gekauft haben.

Bei Kommentaren oder Vorschlägen zu diesem Produkt, der Montageanleitung oder dem Service, den Sie erhalten haben, wenden Sie sich bitte an das nächste Habitat-Geschäft. Sie können auch über unsere Website [www.habitat.net](http://www.habitat.net) mit uns Kontakt aufnehmen oder sich schriftlich unter der folgenden Adresse an uns wenden:  
HABITAT DEUTSCHLAND GMBH BERLINER ALLEE 15, 40212 DÜSSELDORF

# BOCKSEY

Plinth

Plinthe

Zócalo

Fußbodenleiste

135/90 x 45 x 19 cm

965 098 - 965 118 - 965 114 - 965 153

BOCK-PL-AW10-A

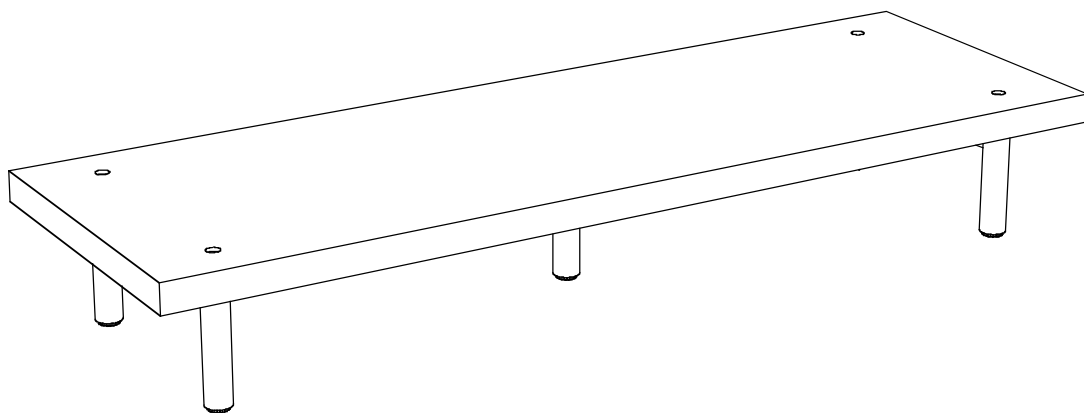
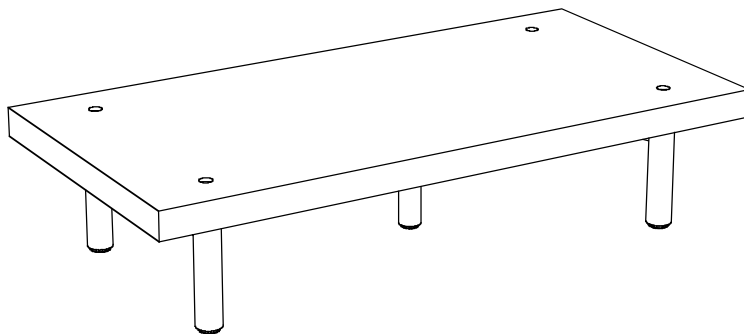
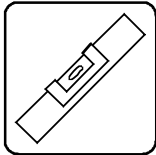
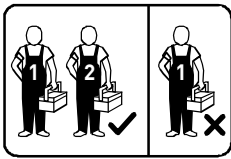

habitat 

# Components / Composants / Componentes / Bestandteile

Ref.: **965 098 - 965 118**

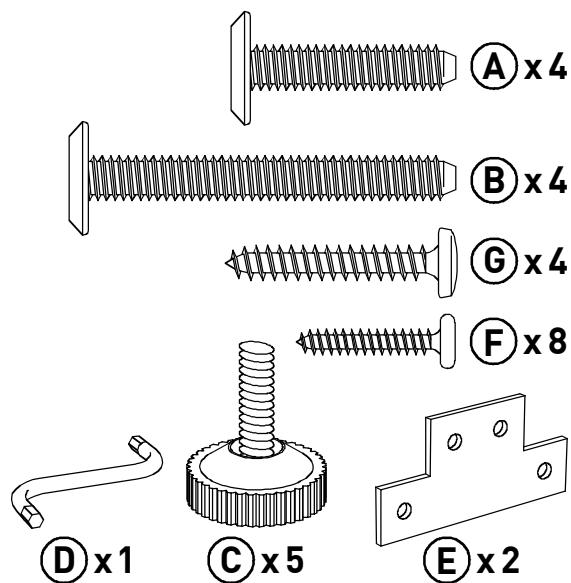
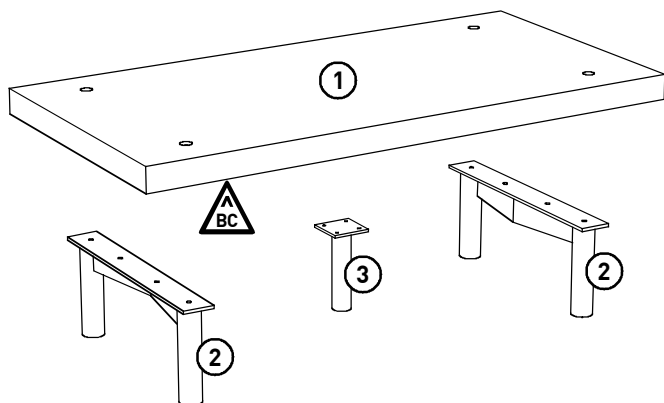

Retain batch code label.  
Préserver l'étiquette indiquant le code du lot.  
Guardar la etiqueta del código de lote.  
Etikett mit Chargen-Nummer bitte aufbewahren.

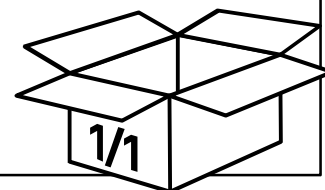

Ref.: **965 114 - 965 153**

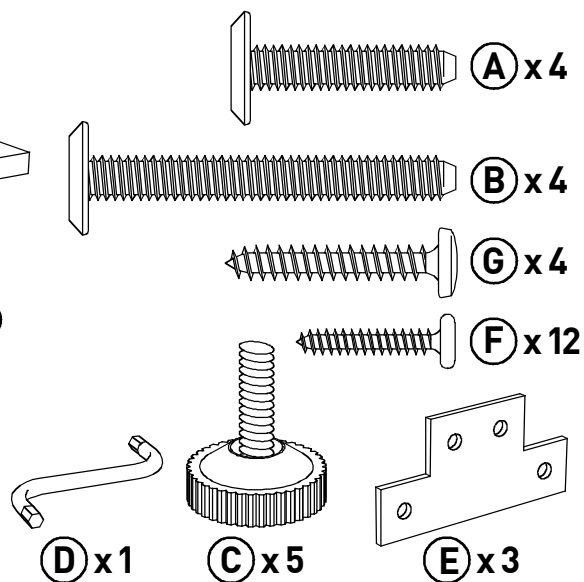
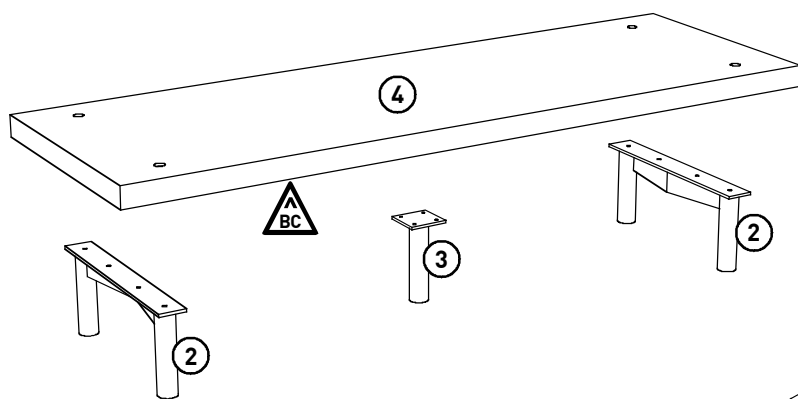

Retain batch code label.  
Préserver l'étiquette indiquant le code du lot.  
Guardar la etiqueta del código de lote.  
Etikett mit Chargen-Nummer bitte aufbewahren.

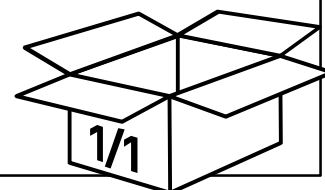

French legislation / Législation française / Legislacion francesa / Französische Gesetzgebung

Panneaux de particules plaqués noyer ou chêne.

Plan to assemble the furniture as near as possible to the place you intend it to be used. Do not place your furniture directly in front of radiators, fires, or any source of direct heat. Ensure that the surface on which you are assembling furniture is clean and flat. Before commencing assembly, please identify all components. Do not discard the packaging until the unit is fully assembled to ensure that no fittings or components are disposed of.

Planifiez d'assembler le meuble aussi près que possible de l'endroit où vous voulez l'installer. Ne pas placer les meubles directement devant un radiateur ou une autre source de chaleur vive. Assurez-vous que la surface sur laquelle vous effectuez le montage soit propre et plane. Avant de débiter le montage, identifiez tous les composants à l'aide de la notice.

Afin de ne pas égarer de composants, ne jetez pas l'emballage avant d'avoir terminé le montage complet.

Ensamblar el mueble lo mas cerca posible del lugar donde lo quiere instalar. No colocar los muebles directamente delante de un radiador o de otra fuente de calor vivo. Asegurese que la superficie sobre la cual efectua el montaje este limpia y sea plana. Antes de iniciar el montaje, identifique todos los componentes con ayuda de la nota. Para no perder los componentes, no tirar el embalaje antes de haber terminado el montaje completo.

Bauen Sie das Möbelstück in der Nähe seines künftigen Standortes zusammen. Die Möbelstücke nicht direkt vor einem Heizkörper oder einer anderen Wärmequelle aufstellen. Vergewissern Sie sich, dass die Fläche, auf der Sie den Zusammenbau vornehmen, eben und sauber ist. Überprüfen Sie vor dem Zusammenbau, ob alle Schrankteile gemäß Montageanleitung vorhanden sind.

Damit keine Bauteile verloren gehen, sollten Sie die Verpackung erst nach dem Zusammenbau wegwerfen.

# 1a

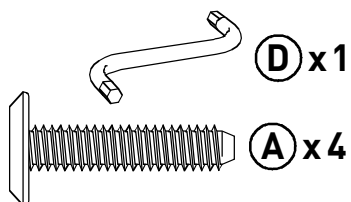
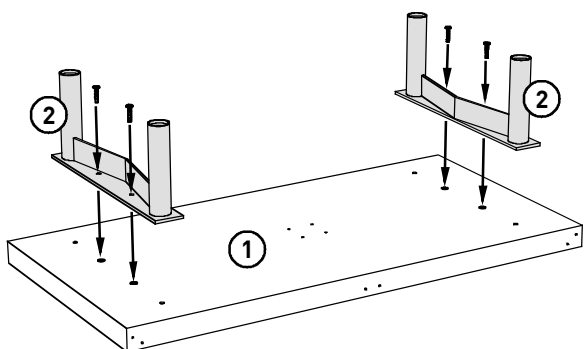

# 1b

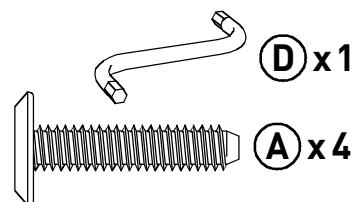
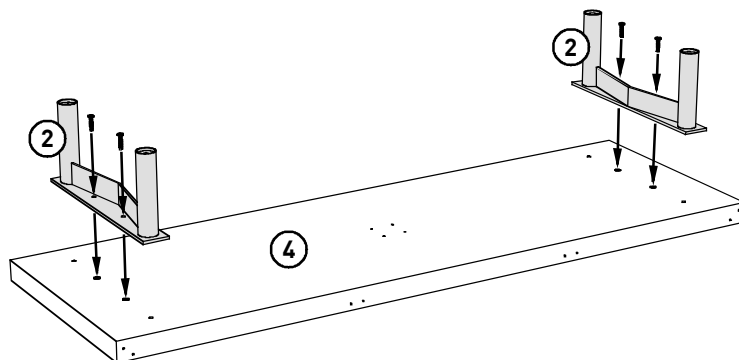

# 2a

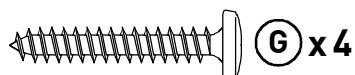
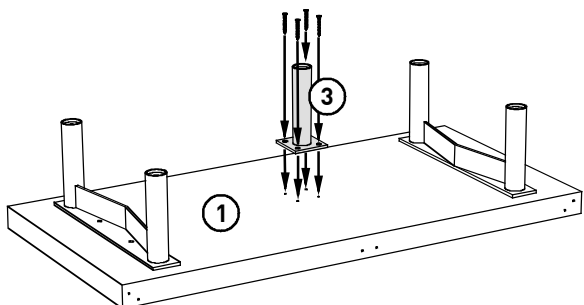

# 2b

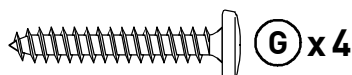
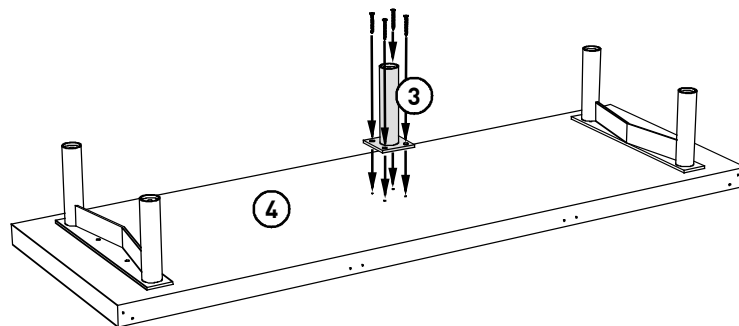

# 3a

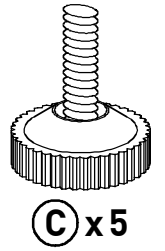
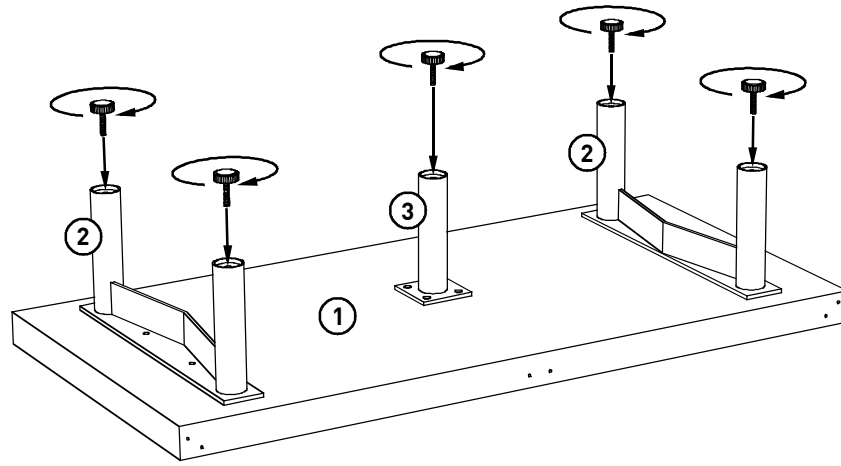

# 3b

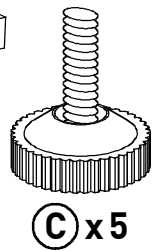
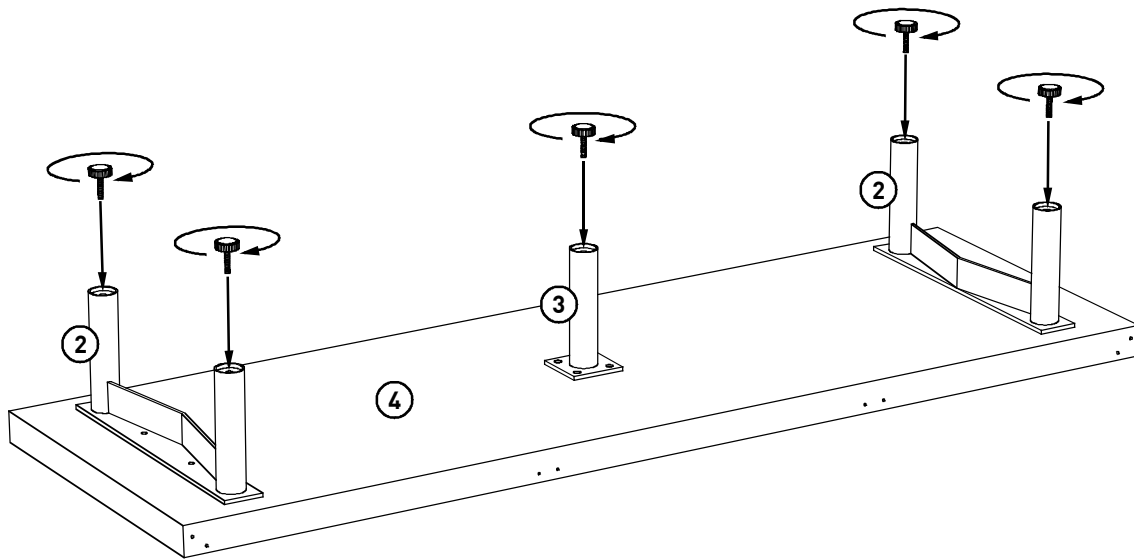

# 4a

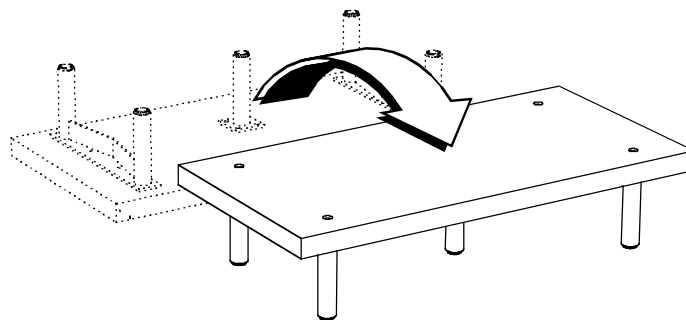

# 4b

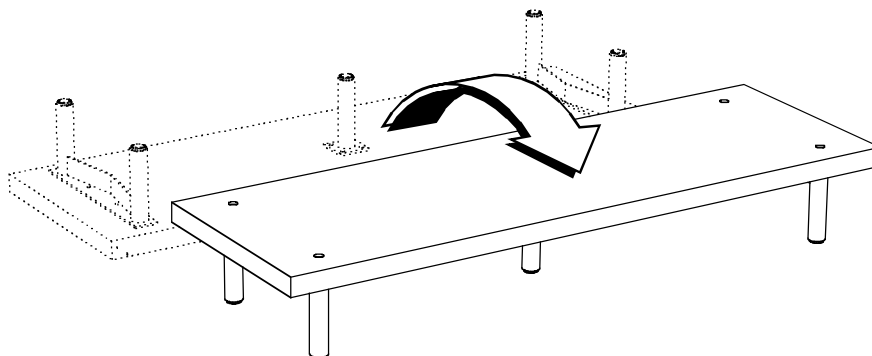

# 5a

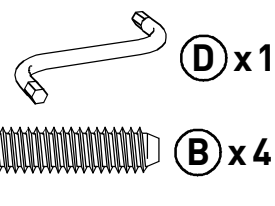
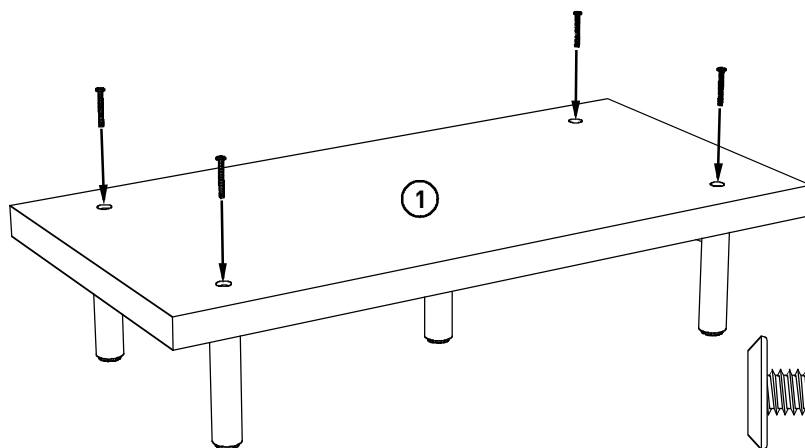

# 5b

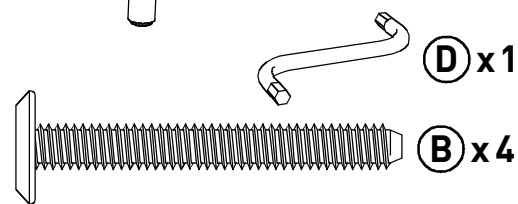
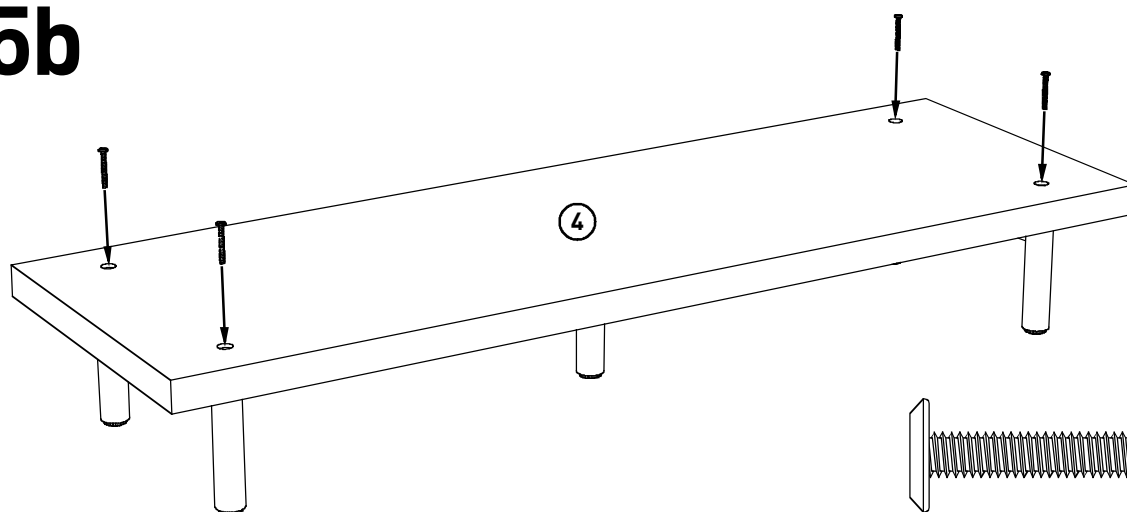

# 6a

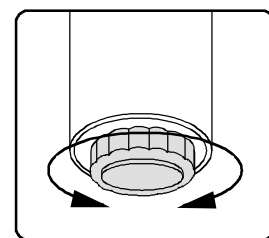
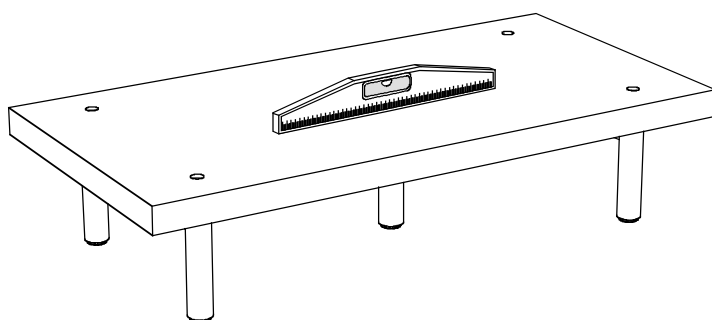

# 6b

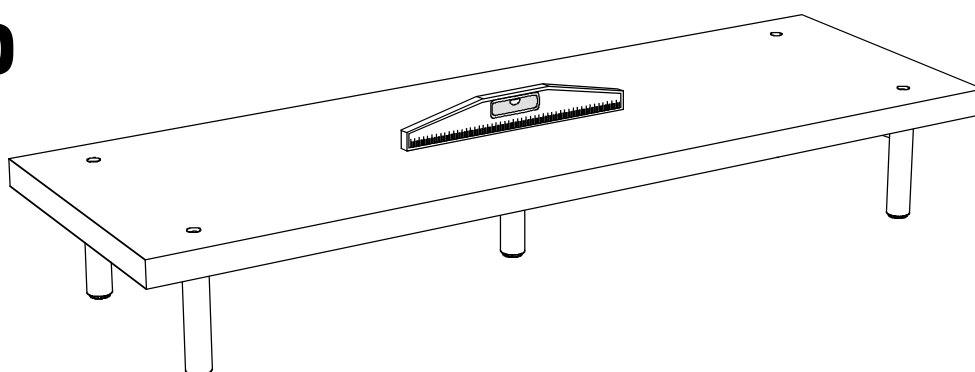

# 7a

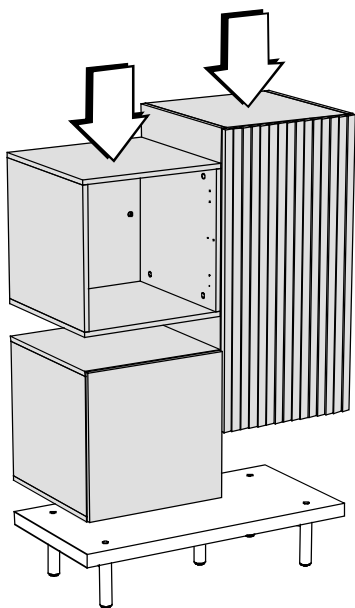

# 7b

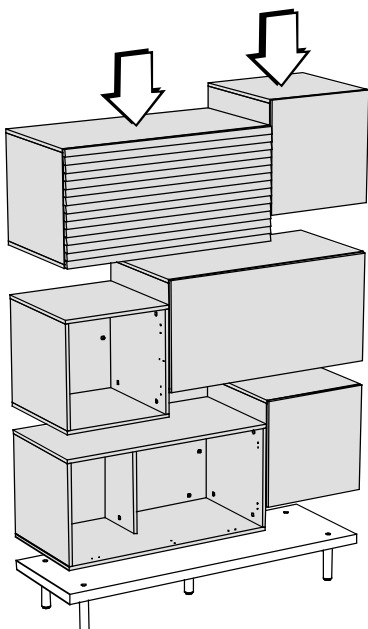

# 8a

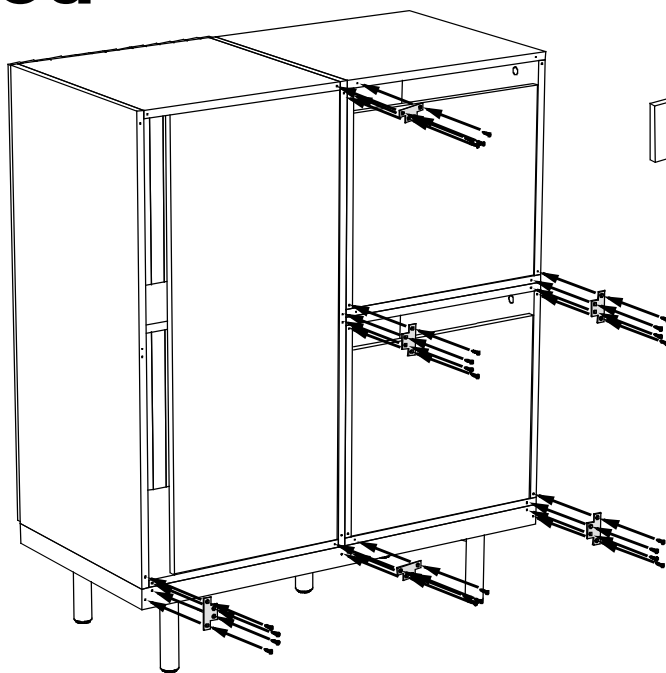

 **F** x4 (xN)

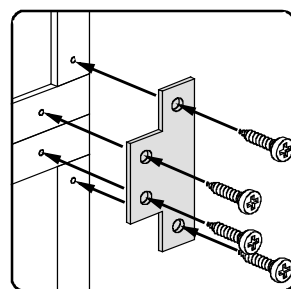
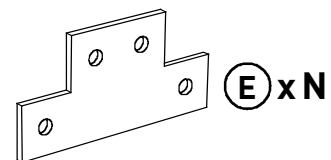

# 8b

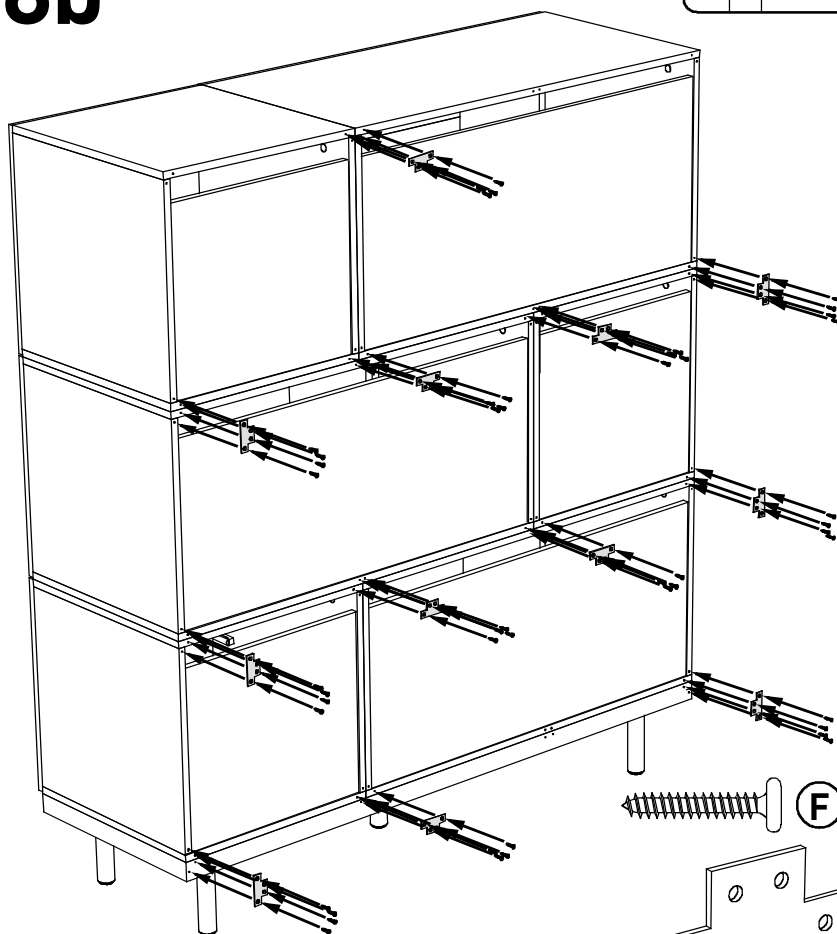

 **F** x4 (xN)

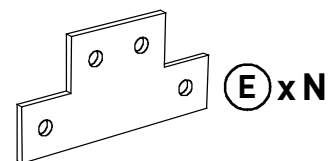



# CARE INSTRUCTIONS / ENTRETIEN / COSEJOS DE MANTENIMIENTO / PFLEGEHINWEISE

## Cleaning of Solid Timber / Veneers and Lacquered Surfaces.

Any spillage should be removed immediately by using a damp cloth, then wiping dry the surface with a clean dry duster. Repeat this procedure for periodic cleaning. The use of furniture polishes or sprays is not necessary or recommended.

## Cleaning of Melamine, Laminate, Linoleum and Metal Surfaces.

Regular dusting with a dry cloth will keep your units clean. However, to remove stubborn stains, wipe over with a damp cloth and washing up liquid. To clean chrome, stainless steel or glass surface, we recommend the use of proprietary cleaners. Always follow the cleaning fluid instructions carefully

If you have any comments or suggestions regarding this product, assembly instructions or service received, please enquire at your nearest store or contact us on our website at: [www.habitat.net](http://www.habitat.net) or write to this address:

HABITAT UK 42-46 PRINCELET STREET LONDON E15LP U.K.

## Nettoyage de bois massif où placage et surfaces laquées.

Les liquides renversés doivent être éponnés immédiatement à l'aide d'un chiffon. Ensuite essuyer la surface à l'aide d'un chiffon propre et sec. L'emploi de produits spéciaux pour meubles n'est pas recommandé ni même nécessaire.

## Nettoyage des mélaminés, stratifiés, linoléum et surfaces métalliques.

Dépoussiérez régulièrement avec un chiffon sec. Pour les tâches rebelles utilisez un produit vaisselle liquide. Pour nettoyez les chromes, acier inoxydable où les glaces, utilisez les produits appropriés

Si vous avez des commentaires ou suggestions quelconques à faire au sujet de ce produit, sur les instructions de montage ou nos services, veuillez vous adresser à votre point de vente le plus proche ou nous contacter sur notre site Web : [www.habitat.net](http://www.habitat.net) ou nous écrire à l'adresse suivante :

HABITAT FRANCE - 33, Avenue de WAGRAM - 75 017 PARIS - FRANCE

## Limpieza de la madera maciza o contrachapada y de la superficies lacadas.

Los líquidos derramados se deben enjuagar inmediatamente con un trapo. Limpiar enseguida la superficie con un trapo limpio y seco. No se recomienda ni es necesario el uso de productos especiales para muebles.

## Limpieza de superficies de melamina, estratificadas, linóleo o metálicas.

Limpe el polvo regularmente con un trapo seco. Para las manchas rebeldes utilice un producto para limpieza de vajilla liquido. Si por cualquier motivo tuviera algún problema con su producto Habitat, póngase en contacto con la tienda donde lo compró.

Si desea hacernos algún comentario o sugerencia acerca de este producto, sus instrucciones de montaje o la calidad del servicio recibido, pregunte en su tienda Habitat más cercana o póngase en contacto con nosotros a través de nuestro sitio web, [www.habitat.net](http://www.habitat.net), o escribanos a la siguiente dirección: HABITAT S.A. - C/Tuset, 20-24. 4º8, - 08006 BARCELONA - SPAIN

## Reinigung von massiven Hölzern, Furnieren und lackierten Flächen.

Verschüttete Flüssigkeiten müssen sofort mit einem Tuch aufgewischt werden. Danach mit einem trockenen und sauberen Tuch nachwischen. Diesen Vorgang bei regelmäßige Reinigung wiederholen. Die Verwendung eines Spezialreinigers für Möbel ist nicht ratsam und nicht erforderlich.

## Reinigung von beschichteten und metallischen Flächen, sowie Linoleum-, und Melaminharzflächen.

Regelmäßig mit einem trockenen Tuch Staub wischen. Bei hartnäckigen Flecken etwas flüssiges Spülmittel verwenden. Zum Reinigen von Chrom, rostfreiem Stahl oder Spiegeln Spezialreiniger benutzen. Falls Sie Probleme mit Ihrem Habitat-Produkt haben sollten, wenden Sie sich bitte an das Geschäft, in dem Sie das Produkt gekauft haben.

Bei Kommentaren oder Vorschlägen zu diesem Produkt, der Montageanleitung oder dem Service, den Sie erhalten haben, wenden Sie sich bitte an das nächste Habitat-Geschäft. Sie können auch über unsere Website [www.habitat.net](http://www.habitat.net) mit uns Kontakt aufnehmen oder sich schriftlich unter der folgenden Adresse an uns wenden: HABITAT DEUTSCHLAND GMBH BERLINER ALLEE 15, 40212 DÜSSELDORF

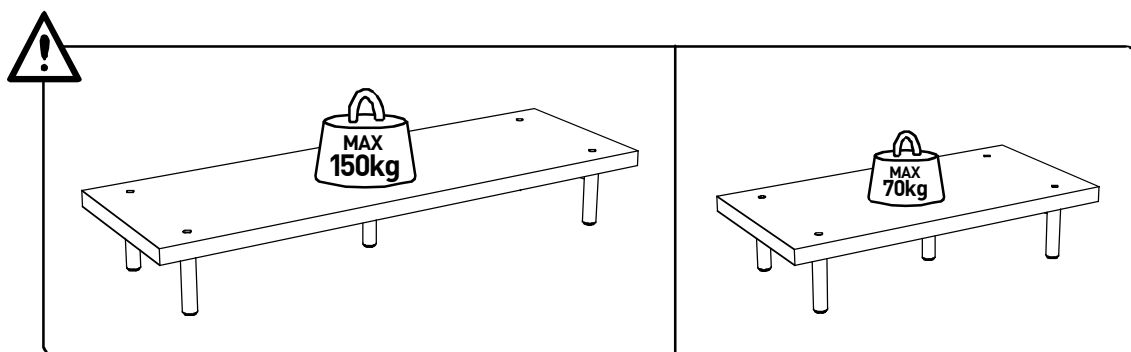

# BOCKSEY

Storage unit

Rangement

Ordenación

Aufräummöbel

45 x 45 x 45 cm - 965 095 - 965 115 - 965 155 - 965 154

45 x 46,5 x 45 cm - 965 096 - 965 116 - 965 157 - 965 156 - 902 193 - 902 198

45 x 47 x 45 cm - 965 097 - 965 117 - 965 159 - 965 158 - 902 194 - 902 199

BOCK-SU-AW10-B

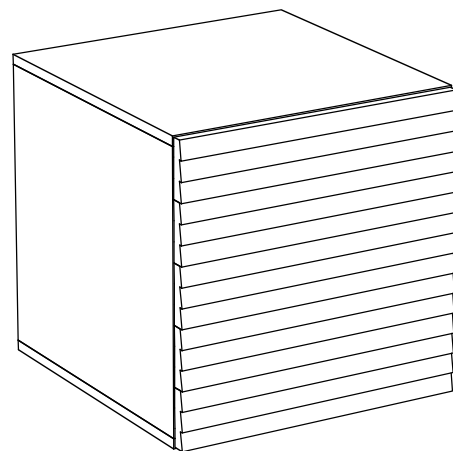
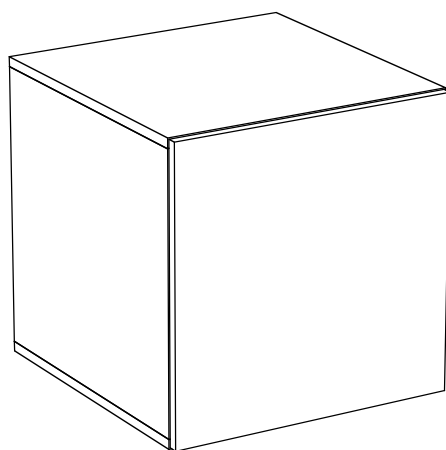
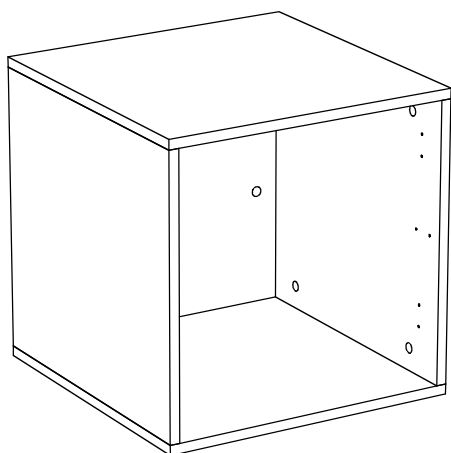
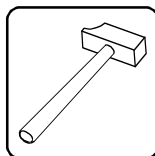
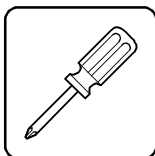
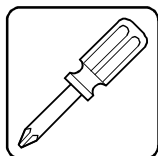
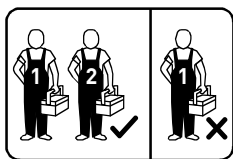

habitat 

# Components / Composants / Componentes / Bestandteile

Ref.: 965 095 - 965 115 - 965 155 - 965 154

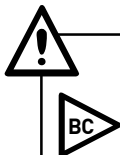
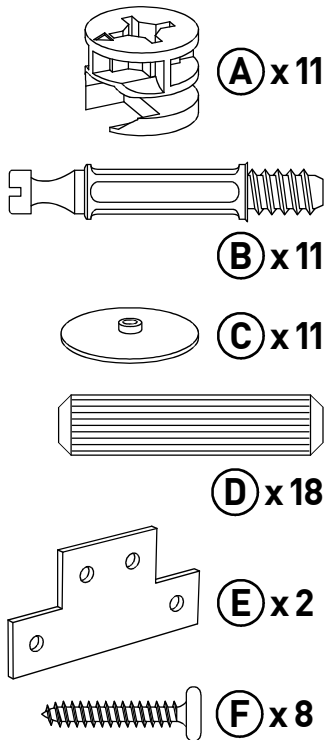
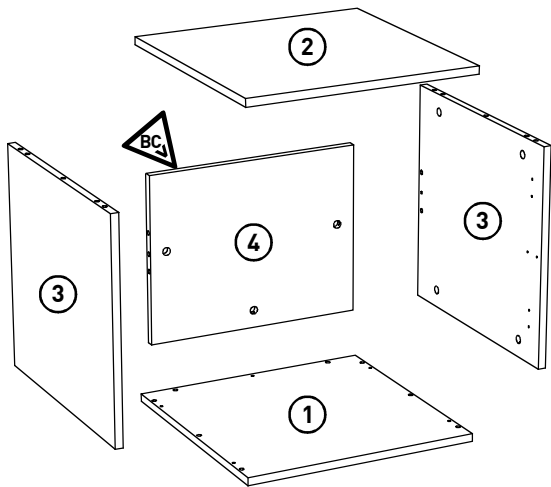

Retain batch code label.  
Préserver l'étiquette indiquant le code du lot.  
Guardar la etiqueta del código de lote.  
Etikett mit Chargen-Nummer bitte aufbewahren.

Ref.: 965 096 - 965 116  
965 157 - 965 156  
902 193 - 902 198

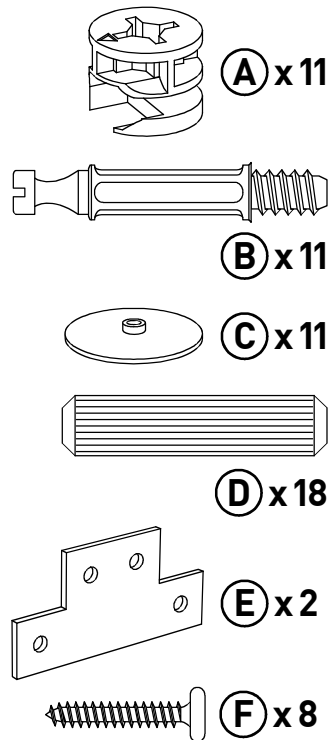
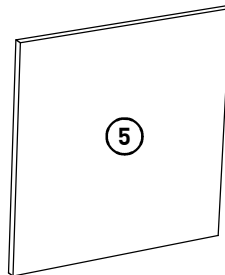

Ref.: 965 097 - 965 117  
965 159 - 965 158  
902 194 - 902 199

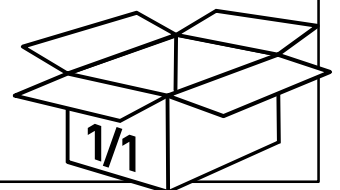
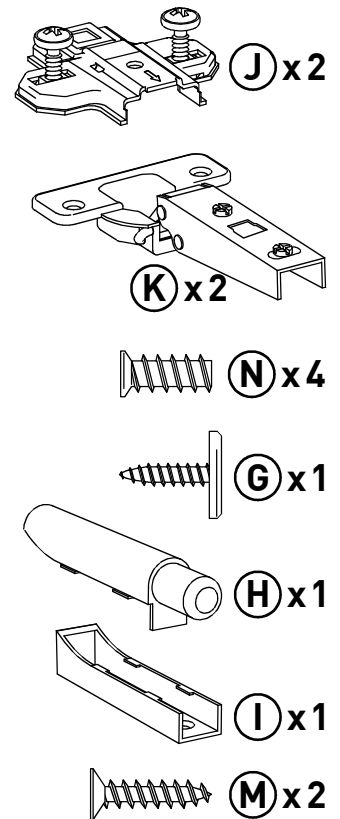
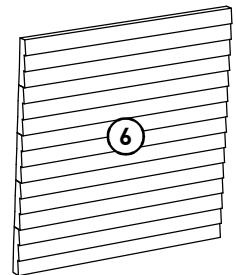

French legislation / Législation française / Legislacion francesa / Französische Gesetzgebung

Structure en panneaux de particules plaqués chêne, érable ou noyer ou laqué rouge tomate, anthracite ou blanc. Porte à lattes en chêne, érable ou noyer massif ou en MDF laqué rouge tomate, anthracite ou blanc. Porte pleine en panneaux de particules plaqués chêne, érable ou noyer ou laqué rouge tomate, anthracite ou blanc.

Plan to assemble the furniture as near as possible to the place you intend it to be used. Do not place your furniture directly in front of radiators, fires, or any source of direct heat. Ensure that the surface on which you are assembling furniture is clean and flat. Before commencing assembly, please identify all components. Do not discard the packaging until the unit is fully assembled to ensure that no fittings or components are disposed of.

Ensamblar el mueble lo mas cerca posible del lugar donde lo quiere instalar. No colocar los muebles directamente delante de un radiador o de otra fuente de calor vivo. Asegurese que la superficie sobre la cual efectua el montaje este limpia y sea plana. Antes de iniciar el montaje, identifique todos los componentes con ayuda de la nota. Para no perder los componentes, no tirar el embalaje antes de haber terminado el montaje completo.

Planifiez d'assembler le meuble aussi près que possible de l'endroit où vous voulez l'installer. Ne pas placer les meubles directement devant un radiateur ou une autre source de chaleur vive. Assurez-vous que la surface sur laquelle vous effectuez le montage soit propre et plane. Avant de débiter le montage, identifiez tous les composants à l'aide de la notice.

Afin de ne pas égarer de composants, ne jetez pas l'emballage avant d'avoir terminé le montage complet.

Bauen Sie das Möbelstück in der Nähe seines künftigen Standortes zusammen. Die Möbelstücke nicht direkt vor einem Heizkörper oder einer anderen Wärmequelle aufstellen. Vergewissern Sie sich, dass die Fläche, auf der Sie den Zusammenbau vornehmen, eben und sauber ist. Überprüfen Sie vor dem Zusammenbau, ob alle Schrankteile gemäß Montageanleitung vorhanden sind.

Damit keine Bauteile verloren gehen, sollten Sie die Verpackung erst nach dem Zusammenbau wegwerfen.

1

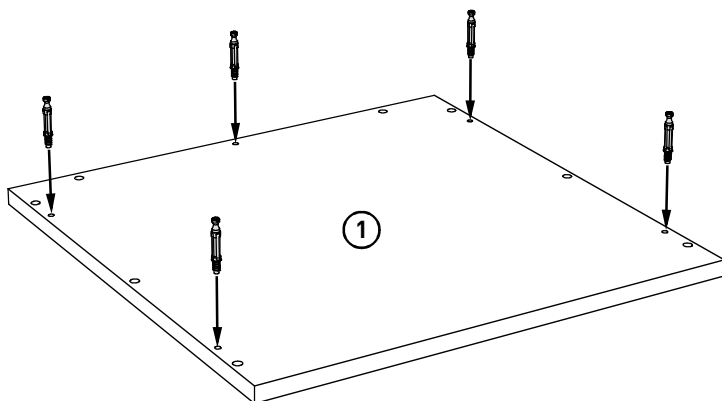

2

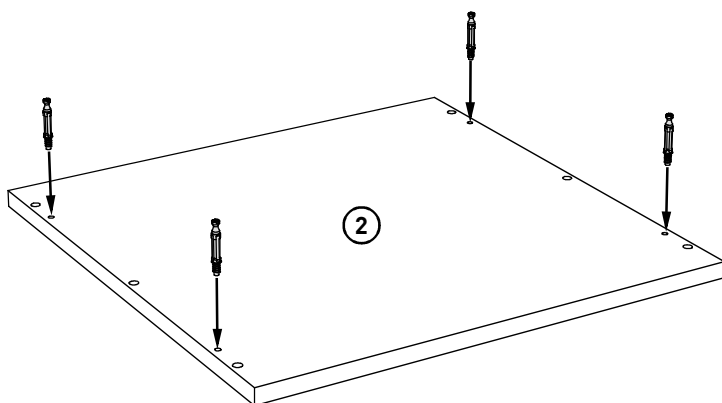

3

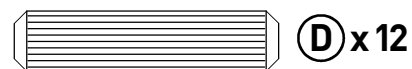
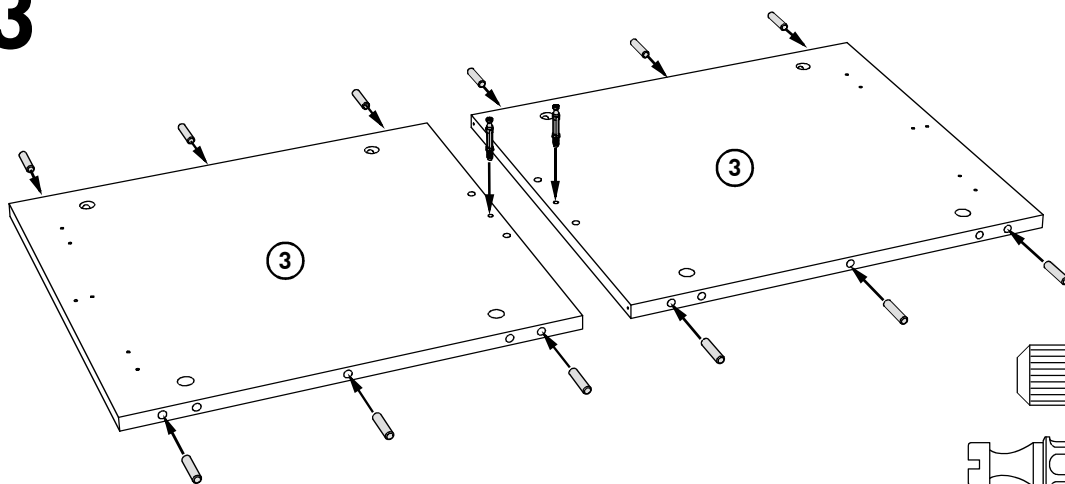

4

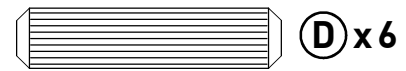
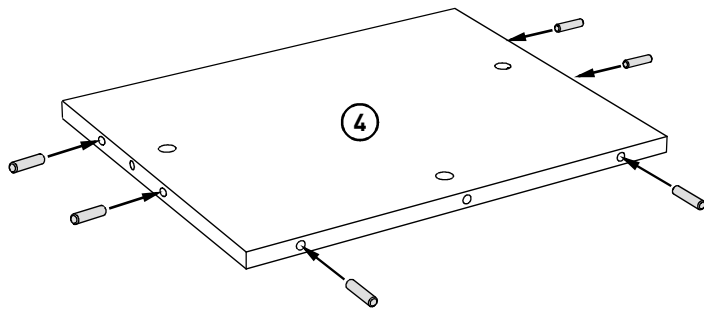

5

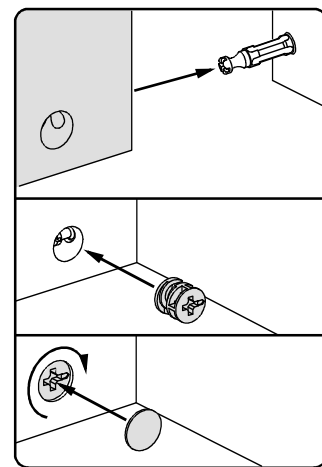
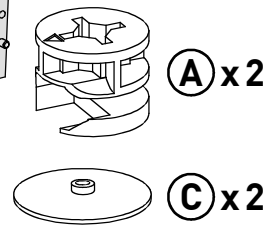
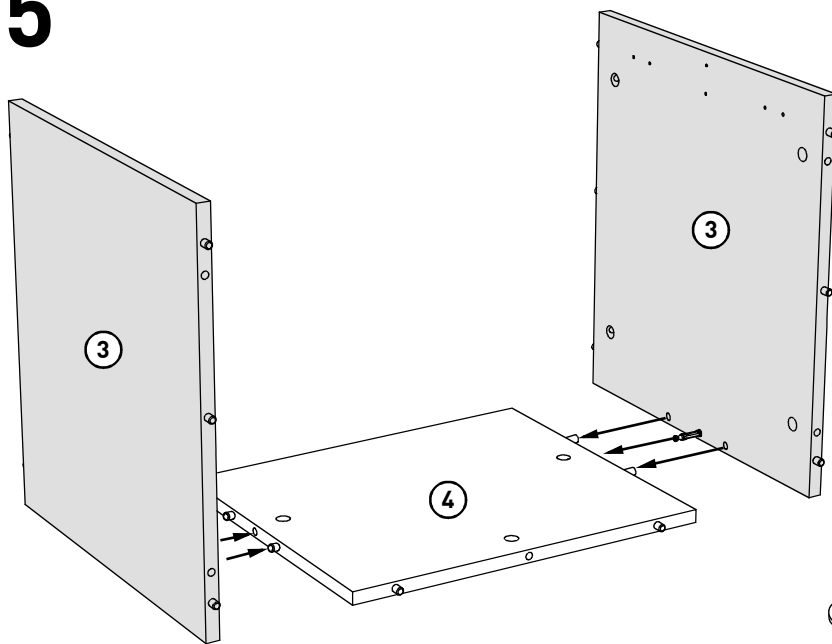

6

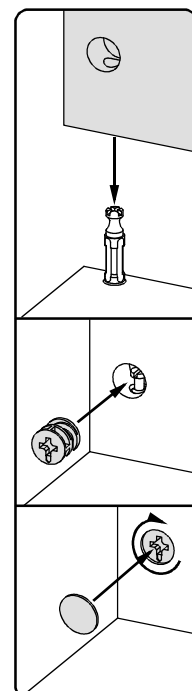
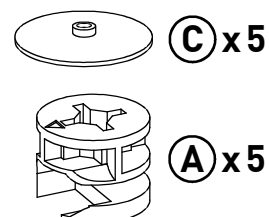
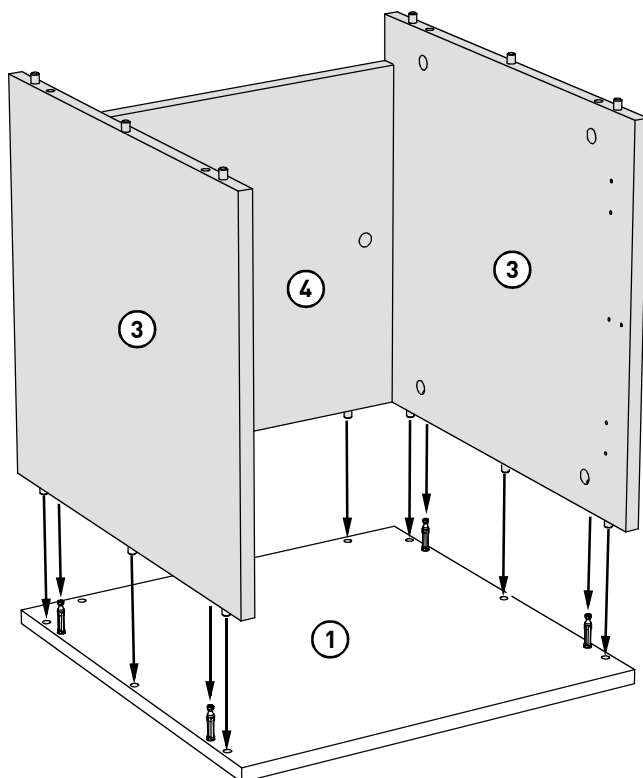

7

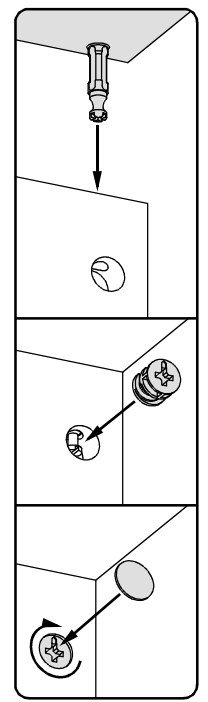
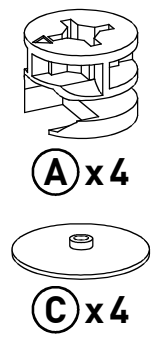
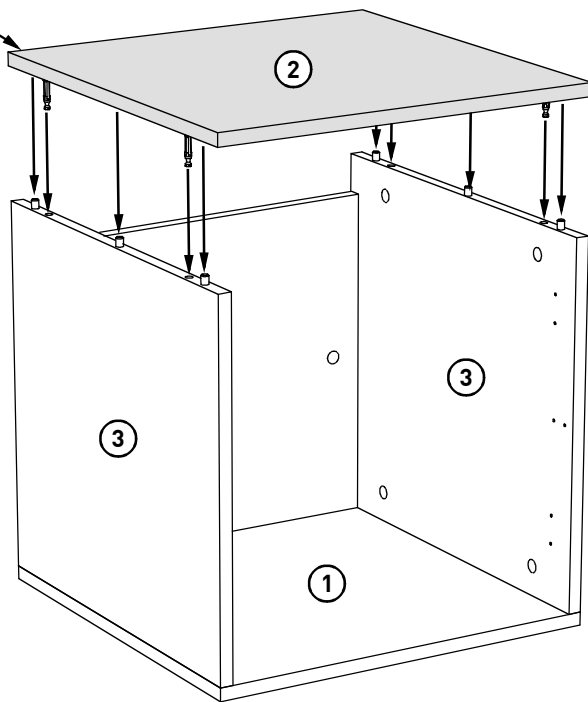
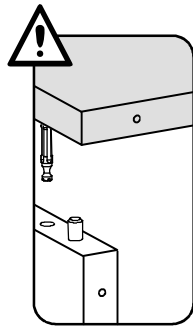

8

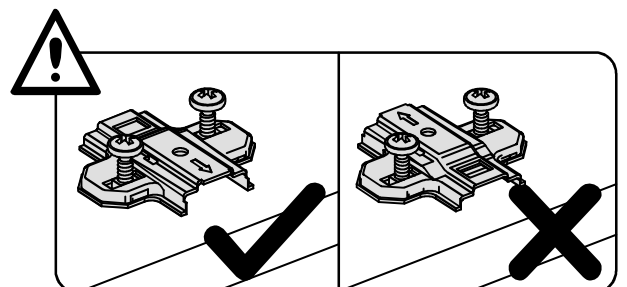
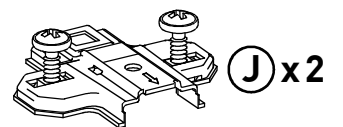
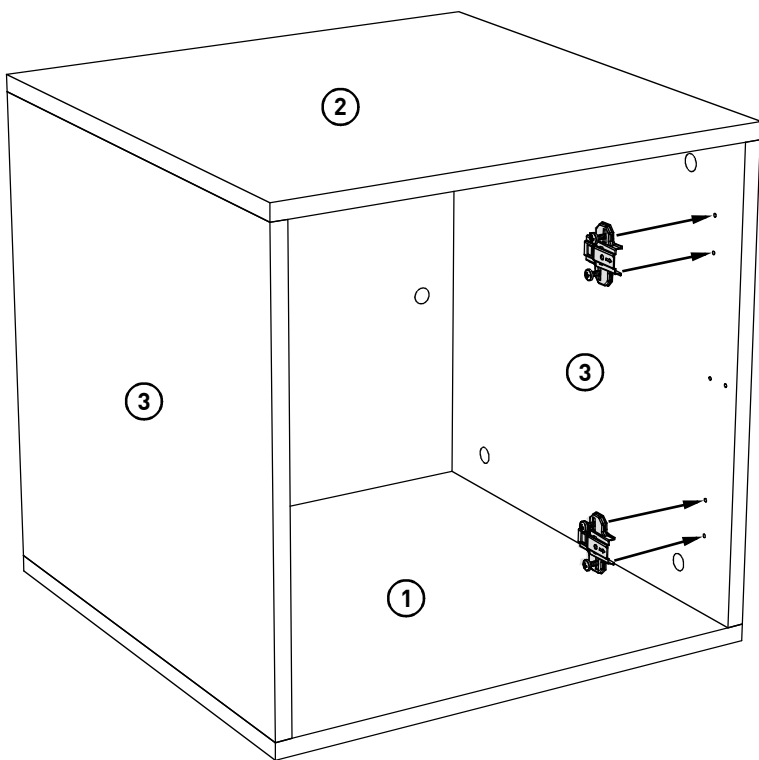

# 9

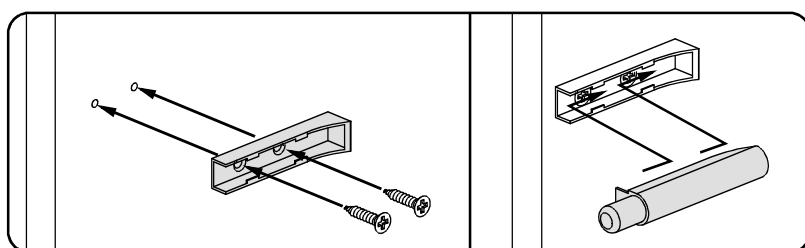
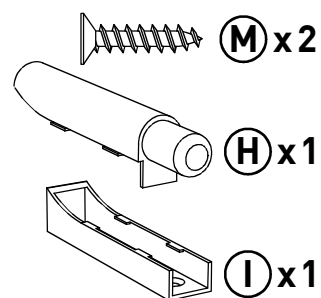
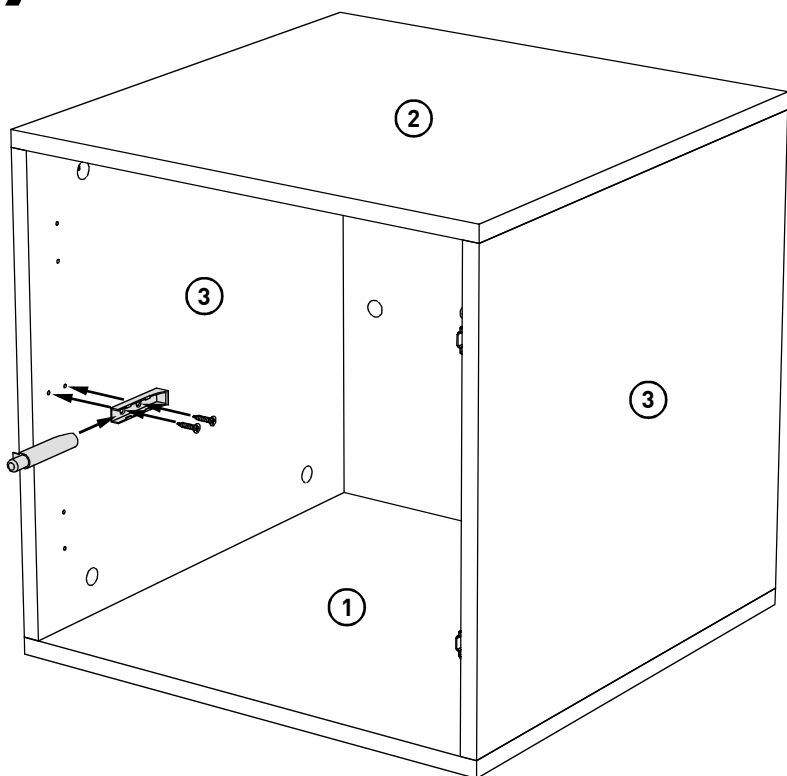

# 10

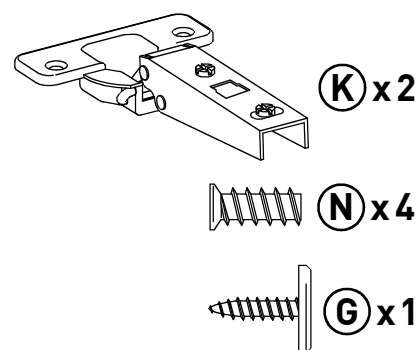
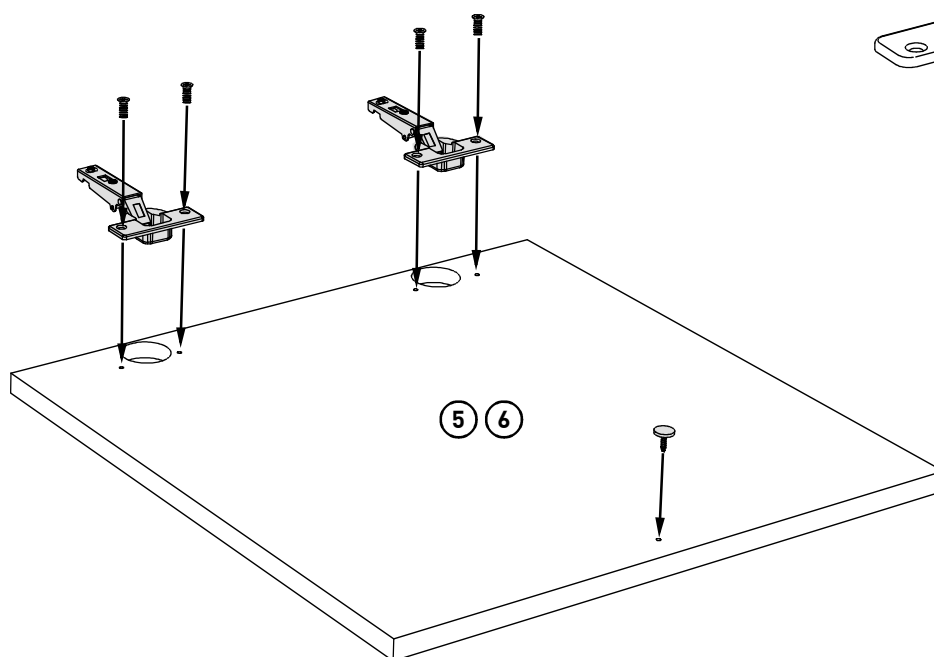

# 11

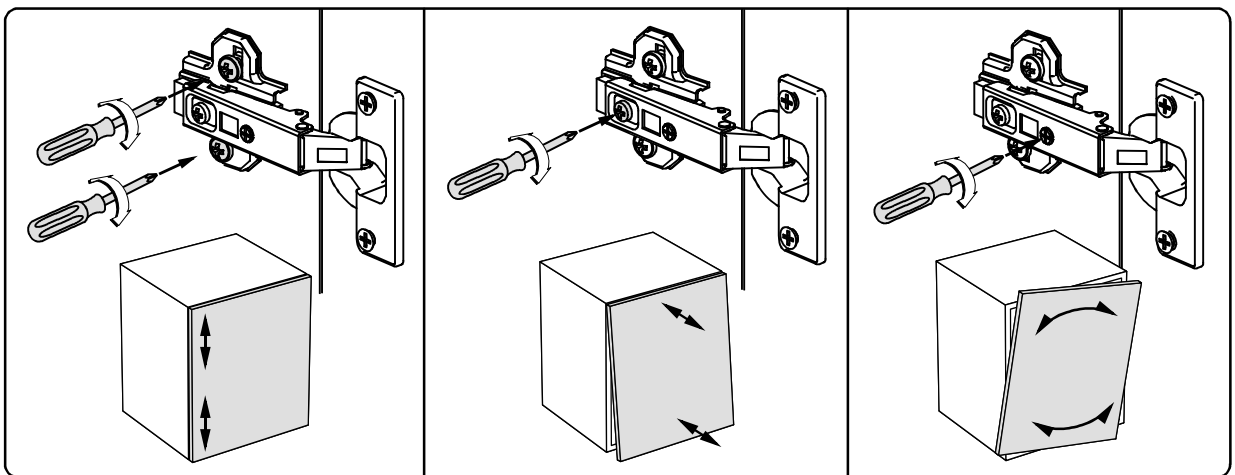
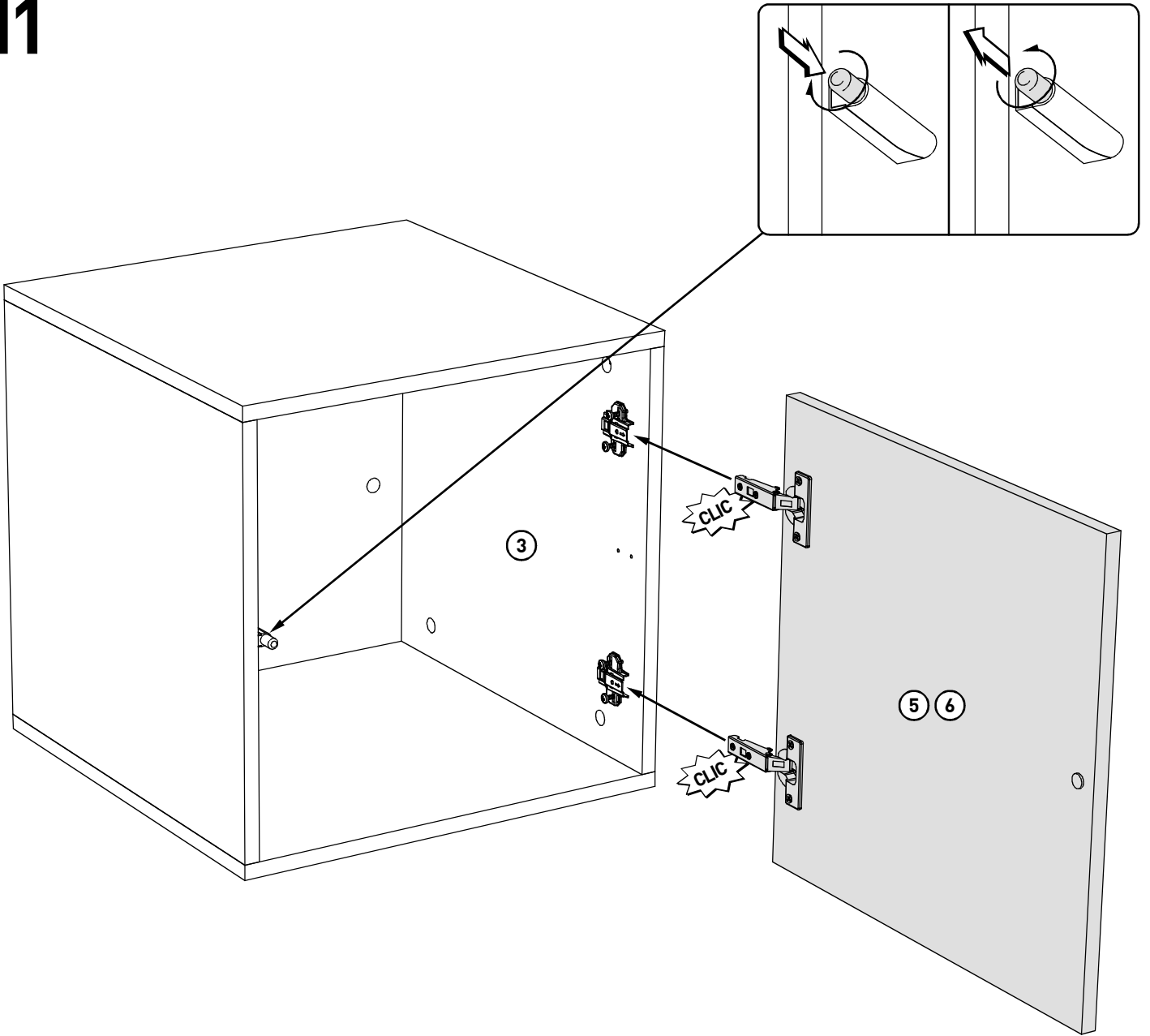



# 12a

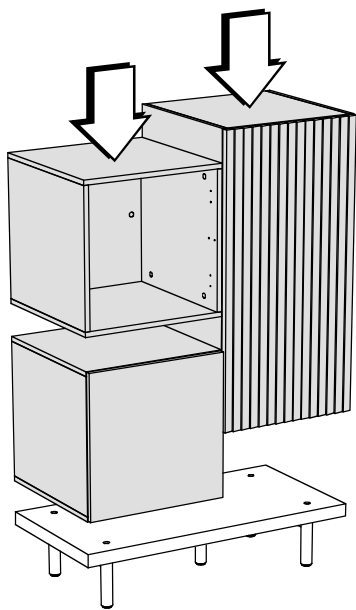

# 12b

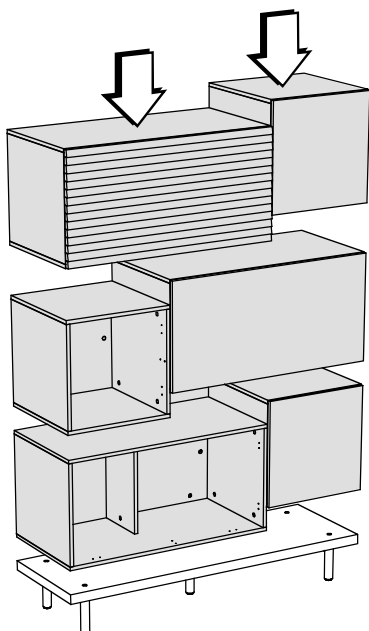

# 13a

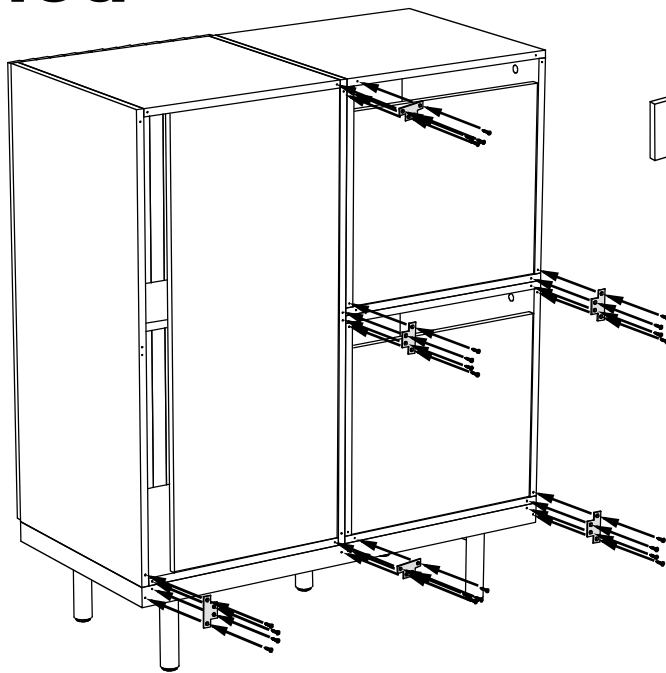

 **F** x4 (x N)

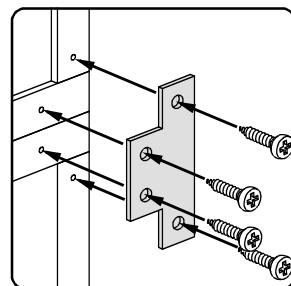
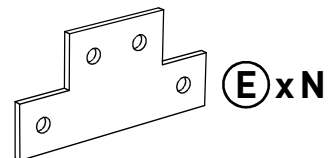

# 13b

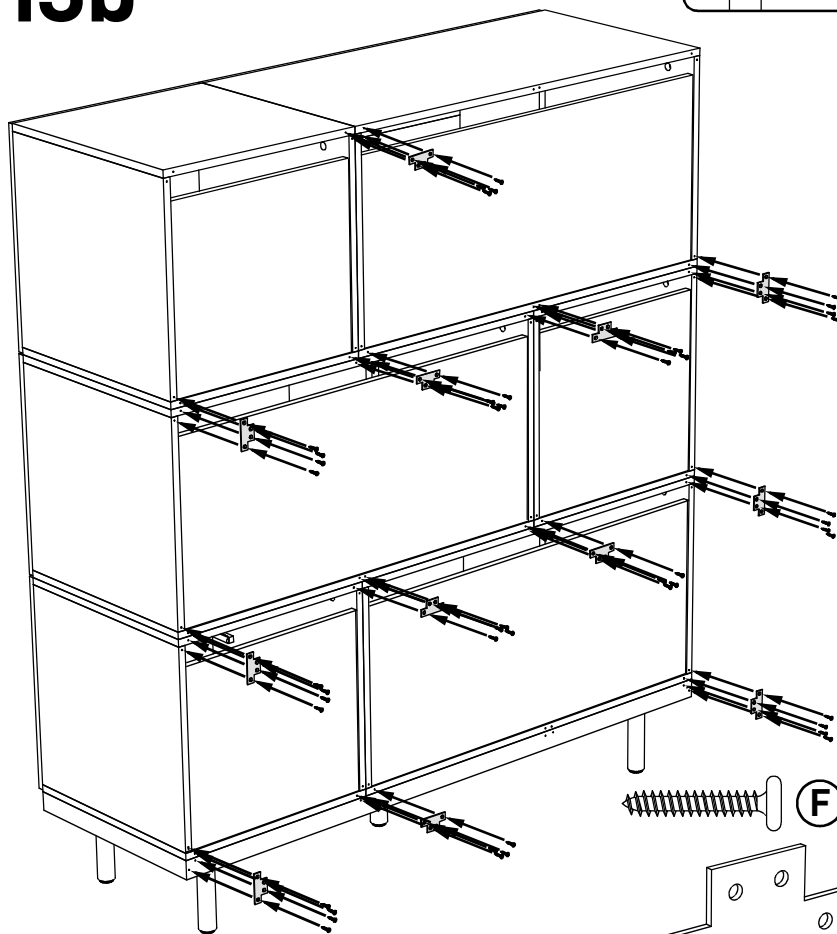

 **F** x4 (x N)

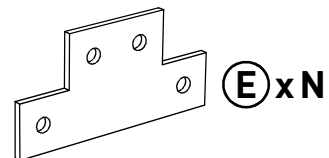

# CARE INSTRUCTIONS / ENTRETIEN / COSEJOS DE MANTENIMIENTO / PFLEGEHINWEISE

## Cleaning of Solid Timber / Veneers and Lacquered Surfaces.

Any spillage should be removed immediately by using a damp cloth, then wiping dry the surface with a clean dry duster. Repeat this procedure for periodic cleaning. The use of furniture polishes or sprays is not necessary or recommended.

## Cleaning of Melamine, Laminate, Linoleum and Metal Surfaces.

Regular dusting with a dry cloth will keep your units clean. However, to remove stubborn stains, wipe over with a damp cloth and washing up liquid. To clean chrome, stainless steel or glass surface, we recommend the use of proprietary cleaners. Always follow the cleaning fluid instructions carefully

If you have any comments or suggestions regarding this product, assembly instructions or service received, please enquire at your nearest store or contact us on our website at: [www.habitat.net](http://www.habitat.net) or write to this address:

HABITAT UK 42-46 PRINCELET STREET LONDON E15LP U.K.

## Nettoyage de bois massif où placage et surfaces laquées.

Les liquides renversés doivent être éponnés immédiatement à l'aide d'un chiffon. Ensuite essuyer la surface à l'aide d'un chiffon propre et sec. L'emploi de produits spéciaux pour meubles n'est pas recommandé ni même nécessaire.

## Nettoyage des mélaminés, stratifiés, linoléum et surfaces métalliques.

Dépoussiérez régulièrement avec un chiffon sec. Pour les tâches rebelles utilisez un produit vaisselle liquide. Pour nettoyez les chromes, acier inoxydable où les glaces, utilisez les produits appropriés

Si vous avez des commentaires ou suggestions quelconques à faire au sujet de ce produit, sur les instructions de montage ou nos services, veuillez vous adresser à votre point de vente le plus proche ou nous contacter sur notre site Web : [www.habitat.net](http://www.habitat.net) ou nous écrire à l'adresse suivante :

HABITAT FRANCE - 33, Avenue de WAGRAM - 75 017 PARIS - FRANCE

## Limpieza de la madera maciza o contrachapada y de la superficies lacadas.

Los líquidos derramados se deben enjuagar inmediatamente con un trapo. Limpiar enseguida la superficie con un trapo limpio y seco. No se recomienda ni es necesario el uso de productos especiales para muebles.

## Limpieza de superficies de melamina, estratificadas, linóleo o metálicas.

Limpe el polvo regularmente con un trapo seco. Para las manchas rebeldes utilice un producto para limpieza de vajilla liquido. Si por cualquier motivo tuviera algún problema con su producto Habitat, póngase en contacto con la tienda donde lo compró.

Si desea hacernos algún comentario o sugerencia acerca de este producto, sus instrucciones de montaje o la calidad del servicio recibido, pregunte en su tienda Habitat más cercana o póngase en contacto con nosotros a través de nuestro sitio web, [www.habitat.net](http://www.habitat.net), o escribanos a la siguiente dirección:  
HABITAT S.A. - C/Tuset, 20-24. 4º8, - 08006 BARCELONA - SPAIN

## Reinigung von massiven Hölzern, Furnieren und lackierten Flächen.

Verschüttete Flüssigkeiten müssen sofort mit einem Tuch aufgewischt werden. Danach mit einem trockenen und sauberen Tuch nachwischen. Diesen Vorgang bei regelmäßige Reinigung wiederholen. Die Verwendung eines Spezialreinigers für Möbel ist nicht ratsam und nicht erforderlich.

## Reinigung von beschichteten und metallischen Flächen, sowie Linoleum-, und Melaminharzflächen.

Regelmäßig mit einem trockenen Tuch Staub wischen. Bei hartnäckigen Flecken etwas flüssiges Spülmittel verwenden. Zum Reinigen von Chrom, rostfreiem Stahl oder Spiegeln Spezialreiniger benutzen. Falls Sie Probleme mit Ihrem Habitat-Produkt haben sollten, wenden Sie sich bitte an das Geschäft, in dem Sie das Produkt gekauft haben.

Bei Kommentaren oder Vorschlägen zu diesem Produkt, der Montageanleitung oder dem Service, den Sie erhalten haben, wenden Sie sich bitte an das nächste Habitat-Geschäft. Sie können auch über unsere Website [www.habitat.net](http://www.habitat.net) mit uns Kontakt aufnehmen oder sich schriftlich unter der folgenden Adresse an uns wenden:  
HABITAT DEUTSCHLAND GMBH BERLINER ALLEE 15, 40212 DÜSSELDORF