



# Russell Hobbs



**23830**

 [www.russellhobbs.com](http://www.russellhobbs.com)

**£10,000 prize draw**

EXTRA year guarantee FREE rewards gallery

[www.russellhobbs.co.uk/productregister/](http://www.russellhobbs.co.uk/productregister/) Register online now! See back for details



1



2

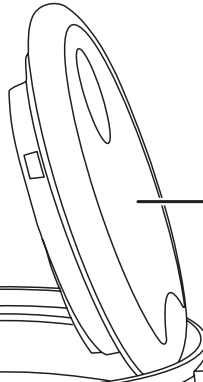

3

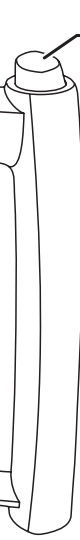

max

4



5

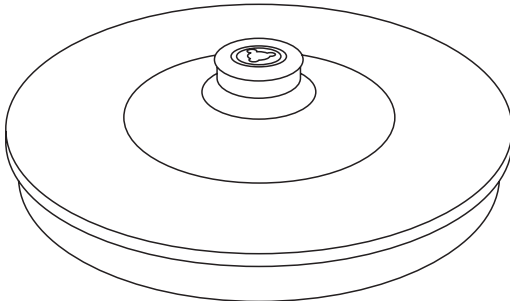

Read the instructions, keep them safe, pass them on= if you pass the appliance on. Remove all packaging before use.

---

## IMPORTANT SAFEGUARDS

Follow basic safety precautions, including:

This appliance can be used by children aged from 8 years and above and persons with reduced physical, sensory or mental capabilities or lack of experience and knowledge if they have been given supervision or instruction concerning use of the appliance in a safe way and understand the hazards involved. Children shall not play with the appliance. Cleaning and user maintenance shall not be made by children unless they are older than 8 and supervised. Keep the appliance and its cord out of reach of children aged less than 8 years.

Keep the appliance and cable out of reach of children under 8 years.

 The surfaces of the appliance will get hot.

If you overfill, the kettle may spit boiling water.

Use the kettle only with the stand supplied (and vice versa).

If the cable is damaged, return the appliance, to avoid hazard.

- ⊗ Do not use this appliance near bathtubs, showers, basins or other vessels containing water.
- Don't put the kettle, stand, cable, or plug in liquid.
- Keep the kettle, stand, and cable away from the edges of worktops.
- Don't use the kettle for any purpose other than heating water.
- Don't operate the appliance if it's damaged or malfunctions.

## HOUSEHOLD USE ONLY

---

### PARTS

- |                |           |
|----------------|-----------|
| 1. Filter      | 4. Switch |
| 2. Lid         | 5. Stand  |
| 3. Lid release |           |

---

### BEFORE USING FOR THE FIRST TIME

Fill to **max**, boil, discard the water, then rinse. Do this twice to remove any manufacturing dust, etc.

---

### FILLING

1. Open the lid.
2. Fill with at least 1 cup of water, but not above max.
3. Close the lid. Always close the lid when boiling the kettle.

---

## USING YOUR KETTLE

1. Put the stand on a stable, level surface.
2. Plug the stand into the wall socket.
3. Put the kettle on the stand.
4. Move the switch to I.
5. The light will come on and the kettle will start to heat up.
6. When the water boils the kettle will switch off.
7. To switch off manually, move the switch to **O**, or simply lift the kettle off the stand.

---

## GENERAL

When you lift the kettle, you may see moisture on the stand. Don't worry – it's the steam used to switch off automatically, which then condenses and escapes via vents under the kettle.

---

## BOIL DRY PROTECTION

1. This will shorten the life of the element. A boil-dry cut-out will switch the kettle off.
2. You must then remove the kettle from its stand to reset the cut-out.
3. Sit the kettle on the work surface till it's cold.

---

## CARE AND MAINTENANCE

1. Unplug the stand, and let the kettle cool before cleaning.
2. Wipe all surfaces with a clean damp cloth.
3. Keep the connectors dry.
4. Open the lid and slide the filter out of the kettle.
5. Rinse the filter under a running tap while brushing with a soft brush.
6. Slide the filter back into the kettle until it clicks.
7. Close the lid.

### **Descale regularly, (at least monthly).**

- Descale the appliance at least monthly with a proprietary descaler. Follow the instructions on the package of descaler.
- Products returned under guarantee with faults due to scale will be subject to a repair charge.







---

## RECYCLING



To avoid environmental and health problems due to hazardous substances, appliances and rechargeable and non-rechargeable batteries marked with one of these symbols must not be disposed of with unsorted municipal waste. Always dispose of electrical and electronic products and, where applicable, rechargeable and non-rechargeable batteries, at an appropriate official recycling/collection point.

---

## SERVICE

If you ring Customer Service, please have the model number to hand, as we won't be able to help you without it. It's on the rating plate (usually underneath the product).

The product isn't user-serviceable. If it's not working, read the instructions, check the plug fuse and main fuse/circuit breaker. If it's still not working, consult your retailer.

If that doesn't solve the problem – ring Customer Service – they may be able to offer technical advice.

If they advise you to return the product to us, pack it carefully, include a note with your name, address, day phone number, and what's wrong. If under guarantee, say where and when purchased, and include proof of purchase (till receipt). Send it to:

Customer Service

Spectrum Brands (UK) Ltd

Fir Street, Failsworth, Manchester M35 0HS

email: [support@russellhobbs.com](mailto:support@russellhobbs.com)

telephone: 0345 658 9700 (local rate number)

---

## GUARANTEE

Defects affecting product functionality appearing within two years of first retail purchase will be corrected by replacement or repair provided the product is used and maintained in accordance with the instructions. Your statutory rights are not affected. Documentation, packaging, and product specifications may change without notice.



---

## ONLINE

[www.russellhobbs.com](http://www.russellhobbs.com) for more products

---

## REGISTER ONLINE FOR –

 £10,000 prize draw,  
 EXTRA year guarantee,  
 FREE rewards gallery

Visit [www.russellhobbs.co.uk/productregister/](http://www.russellhobbs.co.uk/productregister/)

You must register within 28 days of purchase.