

# STAINEXPERT 6

## Carpet & Upholstery Washer

---

USER GUIDE  
21235



More of a video person? Look for this icon and go online for an instructional how-to video at

[www.BISSELL.com](http://www.BISSELL.com)

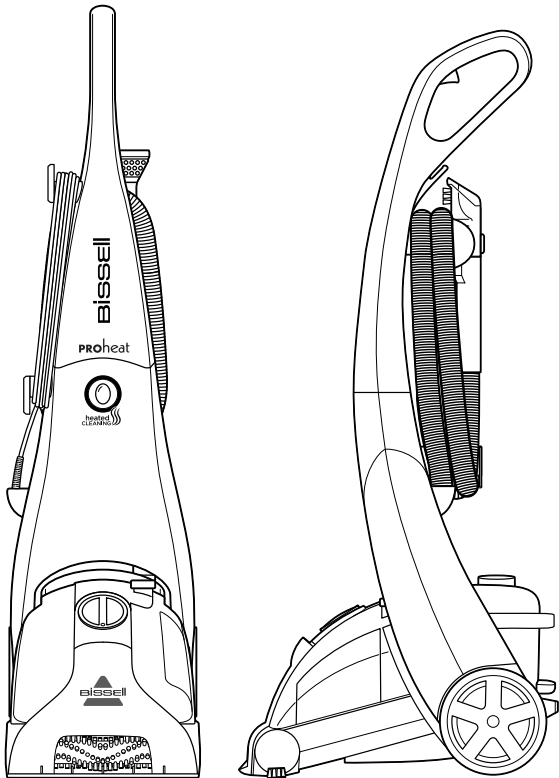

# IMPORTANT SAFETY INSTRUCTIONS

## READ ALL INSTRUCTIONS BEFORE USING YOUR APPLIANCE.

Unplug from outlet when not in use and before conducting maintenance. When using an electrical appliance, basic precautions should be observed, including the following:

### **WARNING**

#### **TO REDUCE THE RISK OF FIRE, ELECTRIC SHOCK, OR INJURY:**

- » This appliance can be used by children aged from 8 years and above and persons with reduced physical, sensory or mental capabilities or lack of experience and knowledge if they have been given supervision or instruction concerning use of the appliance in a safe way and understand the hazards involved. Cleaning and user maintenance shall not be made by children without supervision.
- » Children should be supervised to ensure that they do not play with the appliance.
- » Keep hair, loose clothing, fingers, and all parts of body away from openings and moving parts of the appliance and its accessories.
- » Unplug from electrical socket when not in use, before cleaning, maintaining or servicing the appliance, and if your appliance has an accessory tool with a moving brush, before connecting or disconnecting the tool.
- » If the supply cable is damaged, it must be replaced by the manufacturer, its service agent, or similarly qualified person in order to avoid a hazard.
- » Do not run appliance over cable.
- » Do not leave appliance when plugged in.
- » Do not use with damaged cable or plug.
- » Do not pull or carry by cable, use cable as a handle, close door on cable, or pull cable around sharp edges or corners.
- » Keep cable away from heated surfaces.
- » To unplug, grasp the plug, not the cable.
- » Do not handle plug or appliance with wet hands.
- » Turn off all controls before unplugging.
- » Hold plug when rewinding onto cord reel. Do not allow plug to whip when rewinding.
- » Plastic film can be dangerous. To avoid danger of suffocation, keep away from children.
- » Use only as described in this user guide.
- » Use only manufacturer's recommended attachments.
- » Do not immerse in water or liquid.
- » If appliance is not working as it should, has been dropped, damaged, left outdoors, or dropped into water; do not attempt to operate it and have it repaired at an authorized service center.
- » Do not put any object into openings.
- » Do not use with any opening blocked; keep free of dust, lint, hair, and anything that may reduce air flow.
- » Use extra care when cleaning on stairs.
- » Do not use to pick up flammable or combustible liquids, such as petroleum, or use in areas where they may be present.
- » Do not pick up toxic material (chlorine bleach, ammonia, drain cleaner, etc.)
- » Do not use appliance in an enclosed space filled with vapours given off by oil base paint, paint thinner, some mothproofing substances, flammable dust, or other explosive or toxic vapours.
- » Do not pick up hard or sharp objects such as glass, nails, screws, coins, etc.
- » Keep appliance on a level surface.
- » Do not pick up anything that is burning or smoking, such as cigarettes, matches, or hot ashes.
- » If your appliance has a motorized brushroll, do not leave machine running in the same spot without the handle fully upright.
- » If your appliance is fitted with a nonrewireable BS 1363 plug it must not be used unless a 13 amp (ASTA approved to BS 1362) fuse is fitted in the carrier contained in the plug. Spares may be obtained from your BISSELL supplier. If for any reason the plug is cut off, it must be disposed of, as it is an electric shock hazard should it be inserted into a 13 amp socket.
- » Do not use outdoors.
- » Always connect to a properly earthed electrical socket. Do not modify earthed plug.
- » Liquid must not be directed towards equipment containing electrical components.
- » Do not immerse. Use only on surfaces moistened by the cleaning process. Use only BISSELL cleaning products intended for use with this machine.
- » Use only the type and amount of liquid specified under the operations section of this guide.

### **WARNING**

**DO NOT IMMERSE. USE ONLY ON SURFACES MOISTENED BY THE CLEANING PROCESS. USE ONLY BISSELL CLEANING PRODUCTS INTENDED FOR USE WITH THIS MACHINE.**

**ALWAYS INSTALL FLOAT BEFORE ANY WET PICK-UP OPERATION.**

## SAVE THESE INSTRUCTIONS

**FOR OPERATION ON A 220-240 VOLT A.C. 50-60 HZ POWER SUPPLY ONLY.**

This model is for household use only.

# Thanks for buying a BISSELL carpet cleaner!

We love to clean and we're excited to share one of our innovative products with you. This guide has important instructions on how your new carpet cleaner works, including using (pages 6-8), maintaining (pages 9-10), and if there is a problem, troubleshooting (page 11).

In just a few simple assembly steps, you'll be ready to deep clean. Flip to page 5 and let's get started!

## What's In The Box?

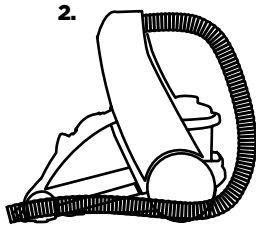
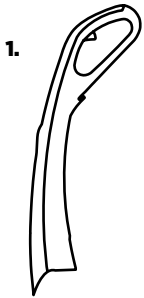

- 1. Upper Handle
- 2. Base
- 3. 3" Tough Stain Tool
- 4. Upper Hose Wrap
- 5. Lower Hose Wrap
- 6. Long Screws (2)  
(taped to Upper Handle)
- 7. Short Screws (2)  
(taped to Upper Handle)
- 8. Nozzle Clean Out Tool
- 9. Trial-Size BISSELL Formula
- 10. 3-in-1 Stair Tool (not shown)



**NOTE:** Not all accessories come with every model. Be sure to check the carton for additional tools.

Safety Instructions.....2

Product View.....4

Assembly.....5

Operations.....6-8

Maintenance & Care.....9-10

Troubleshooting.....11

Guarantee.....12

Service.....12

# Getting to Know Your Deep Cleaner

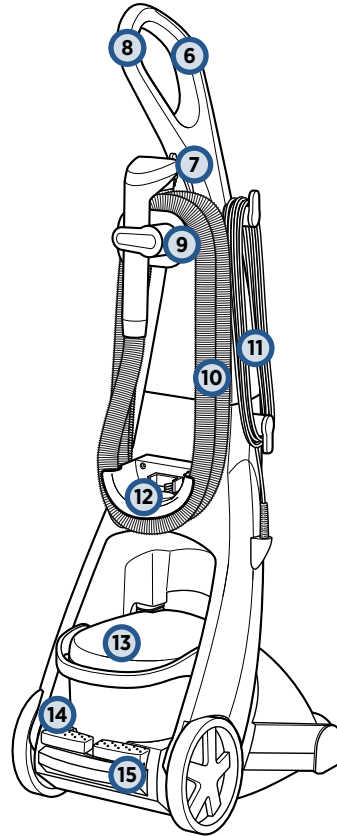
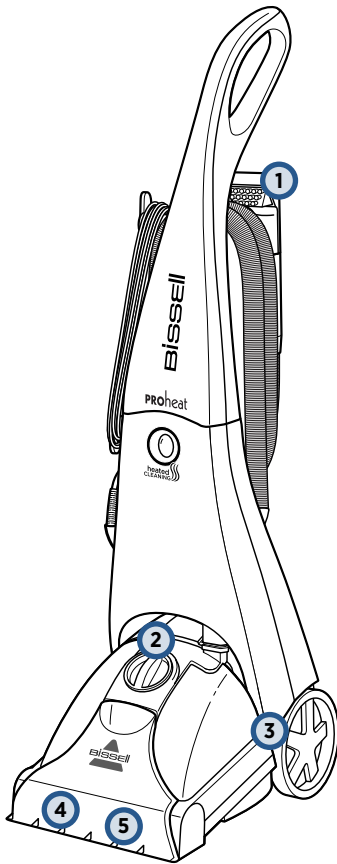

- 1 Tough Stain Tool
- 2 ReadyTools™ Dial
- 3 Belt Access Door
- 4 DirtLifter® PowerBrush (under nozzle)
- 5 Floor Nozzle

- 8 Upper Handle
- 9 Quick Release™ Hose Wrap
- 10 Ready-to-Use Hose
- 11 Extra Long Power Cord
- 12 Lower Hose Wrap
- 13 2-in-1 Tank
- 14 Recline Pedal
- 15 Power Switch

\*Tools included may vary

# Assembly



## ⚠️ WARNING

Do not plug in your deep cleaner until you are familiar with all instructions and operating procedures.

Your deep cleaner comes in four easy-to-assemble components and an accessory bag.

- Upper Handle
- Base
- Upper Hose Wrap
- Lower Hose Wrap

The only tool you will need to assemble your deep cleaner is a Phillips screwdriver.

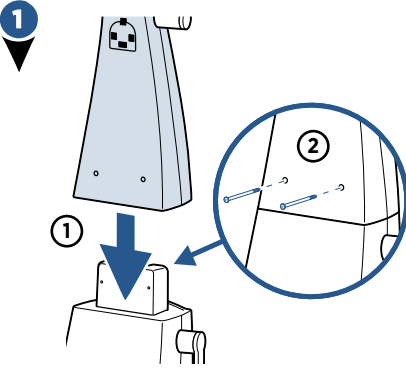
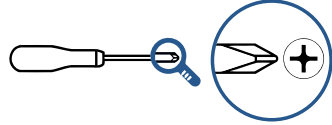

Slide handle assembly onto lower body and secure with two long screws.

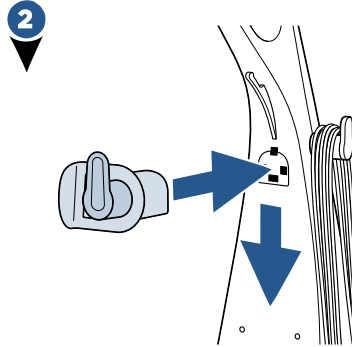

Attach upper hose rack to back of upper handle by pushing into open slots and sliding down until it snaps into place.

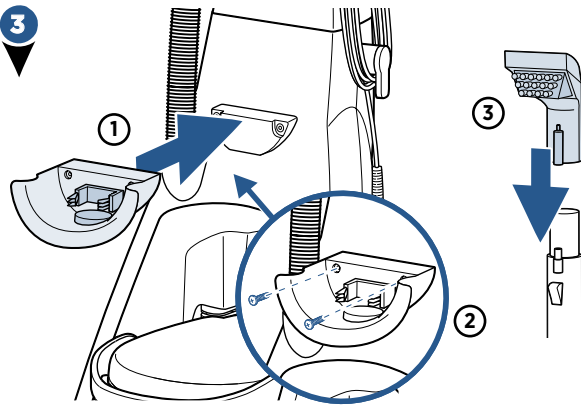



Attach lower hose rack by sliding it in place on the lower body assembly and securing it with 2 short screws.

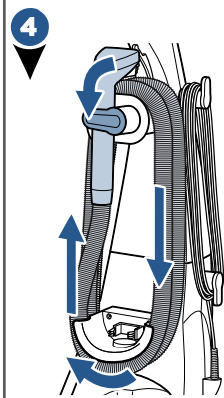

Attach Tough Stain tool to end of hose.

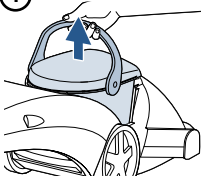

Wrap flex hose around hose rack and secure it into notched holder as shown.

# Before You Clean: Prepare Your Machine

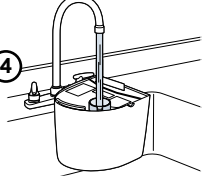
- 1**  **1** Press the recline pedal to access the 2-in-1 tank. Remove the tank from the base of the machine by lifting the tank carry handle.
- 2**  **2** Carry the tank like a bucket to the sink. Rotate the carry handle forward to unlatch the lid. Remove the lid and turn it over to locate the measuring cup.

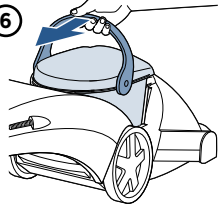
- 2**  **3** Fill with BISSELL 2X formula to the indicated fill line on the built in measuring cup and pour it into the bladder.
- 4**  **4** Fill the bladder with clean hot tap water (140F/60C MAX). \*Do not boil or microwave the water as it can destroy the bladder.
- 5**  **5** Return the tank lid by matching it to the tank edges. The tank handle must be in the forward position in order to set the lid in place. Rotate the handle to secure the latch.
- 6**  **6** Seat the tank firmly back into the machine base. Rotate the tank handle back into latched position.
- Note: Remember to secure the lid before picking up the tank.**
- \*\*If you are using BISSELL Boost formulas, measure out the formula by the bottle's instructions and add it to the bladder at this time.**

**NOTE:** Heatwave Technology™ helps maintain the temperature of the water in your 2-in-1 tank while you're cleaning.

**Heatwave**  
Technology

## Maximize Results with your ProHeat Deep Cleaner...

- Plan activities to give your carpet time to dry.
- Move furniture to another area if cleaning an entire room (optional).
- Remove loose dirt and impediments before deep cleaning.
- Plan your cleaning route to leave an exit path. It is best to begin cleaning in the corner farthest from your exit.
- **Pretreat**  
Pretreating your carpet is recommended to improve cleaning effectiveness for heavily soiled carpet in high traffic areas such as entryways and hallways.
  - a. Spray BISSELL Stain PreTreat formula onto heavy traffic areas, soiled areas, or stains.
  - b. Allow to penetrate for at least 3 minutes.
  - c. Use the ProHeat machine on the high traffic setting.

# Carpet Cleaning

**TIP:** Remove loose dirt and impediments before cleaning.

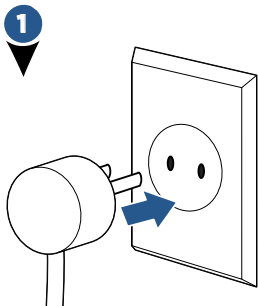

1 Plug the power cord into a properly grounded outlet.

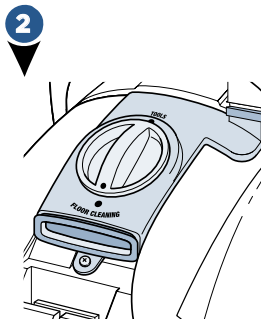

2 Set the ReadyTools Dial to "FLOOR CLEANING".

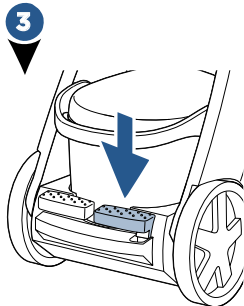

3 Turn the power on by pressing the red Power Switch on the back of the machine with your foot.

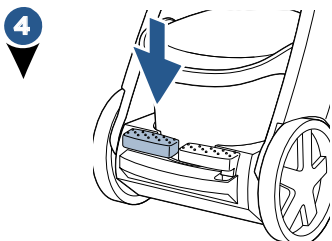

4 Recline the machine by pressing the gray release switch with your foot.

**NOTE:** Do not overwet the carpet. Also take care not to run over loose objects, edges of area rugs, or the power cord.

**NOTE:** Stalling the brush by running over loose objects, edges of area rugs, or the power cord may cause the belts to snap and break.

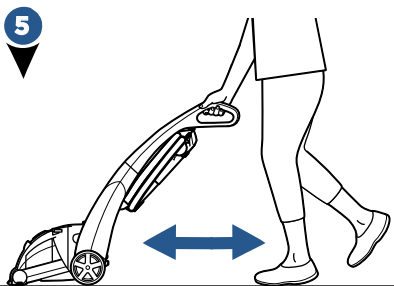

5 While pressing the trigger, make one slow pass forward and back to put water and formula down.

Release the trigger and make one slow pass forward and back over the same area to pick up the water and formula that was just put down.

Repeat until the liquid coming up appears clean. Continue passes without pressing the trigger until you can't see any more water being suctioned up.

**ATTENTION:** To prevent damage to Berber carpets, avoid repeated strokes in the same area.

**NOTE:** You may notice hair and debris deposits on the carpet or in the tank that were loosened by the cleaning action (especially with newer carpets that may have never been deep cleaned before). This debris should be picked up and thrown away.

# Upholstery & Spot Cleaning

**IMPORTANT:** Check upholstery tags for any special care instructions. If possible, check for colored stuffing as it is possible the color could bleed through. Check for colorfastness in a hidden area - like the back or underside of the furniture.

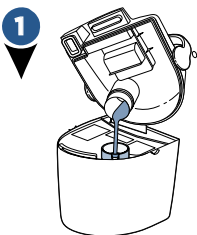

1  
Fill the tank according to page 6 to prepare your machine.

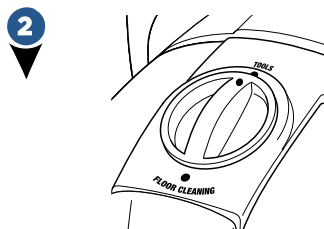
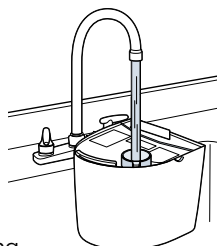

2  
Set the Ready Tools Dial to the Tools setting. This will allow the machine to divert the spray and suction to the hose.

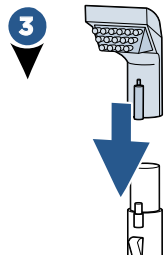

3  
Attach the cleaning tool to the end of the hose.

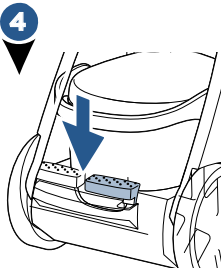

4  
Plug the power cord into a grounded outlet and press the Power Switch Pedal to turn the machine ON.

**Be cautious:** the brush roll on the foot of the machine will spin while using the hose. Ensure the machine is not reclined or tilted while using the hose.

Press the trigger on the hose to spray solution on to the area you are cleaning. Slowly move the tool back and forth over the soiled surface. Release the trigger to suction up the soiled area. Work in small sections. **Optional:** Spray and suction with only warm water to rinse the cleaned area.

**NOTE:** It is recommended that you suction warm water from the tap to rinse out the hose. Before wrapping the hose back on the machine, extend the hose to ensure water is out of the hose. Allow the hose and tool time to dry before storing.

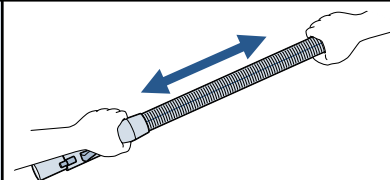

## WARNING

**WARNING:** To reduce the risk of injury, be extra careful when cleaning stairs. Make sure the machine is secure and level.



# Empty the 2-in-1 Tank

## WARNING

To reduce the risk of fire, electric shock or injury, turn power OFF and disconnect plug from electrical outlet before performing maintenance or troubleshooting.

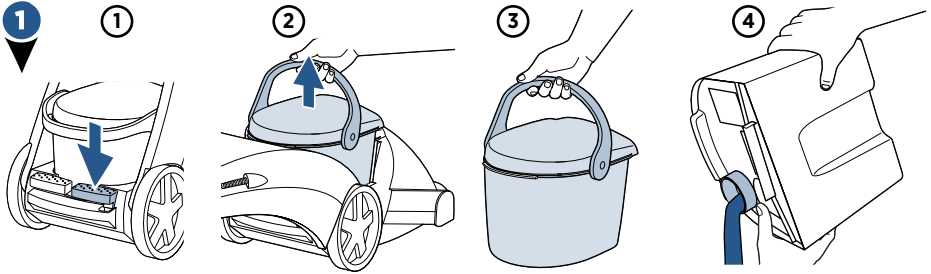

**1**-Press the Power Switch Pedal with your foot to turn the machine OFF. **2**-Remove the 2-in-1 Tank by lifting up with the tank's Carry Handle. **3**-Carry the tank like a bucket to where you'll dispose of the collection water. **4**-Rotate the carry handle to unlatch the lid and empty the tank.

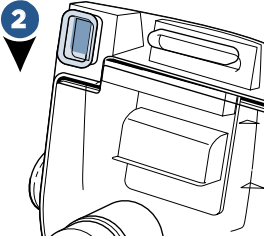

**2**  
After each use, remove the tank lid and rinse the lint screen.

**NOTE:** You may notice hair and debris deposits on the carpet or in the tank that were loosened by the cleaning action (especially with newer carpets that may have never been deep cleaned before). This debris should be picked up and thrown away.

Once your cleaning is complete, make sure the water tank is emptied and rinsed out. Put the unit away in a closet or basement for the next use.

**NOTE:** Store cleaner in a protected, dry area. Since this product uses water, it must not be stored where there is a danger of freezing. Freezing will damage internal components and void the guarantee.

# Clean the Removable Nozzle

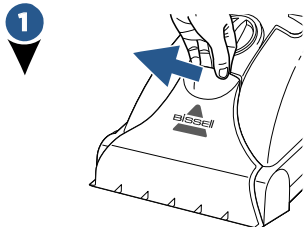

**1**  
Turn the machine OFF. Grasp the handle at the top of the nozzle and pull forward. The nozzle will come off to rinse with water in the sink. The Nozzle Clean Out Tool may be handy at this time as well.

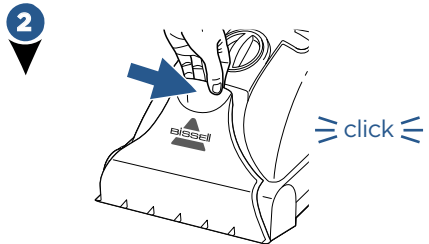

**2**  
Return the nozzle by slightly raising the foot of the machine and lining up hooks of the nozzle. Attach and "click" into place.

# Machine Care

A few simple steps can assure your machine is well maintained after your cleaning is complete.

1

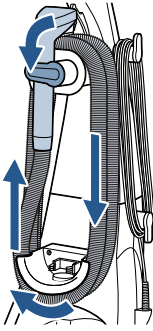

Turn power OFF and unplug the machine. Always wrap the power cord and make sure the hose is securely wrapped.

2

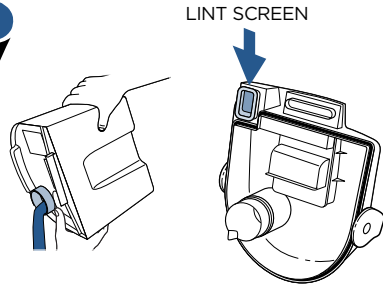

The final empty of the 2-in-1 tank should always get an extra rinse-out. Rinse under and around the bladder as well as the lint screen.

## Belt Replacement



1

### Brush Belt

Insert a Flat Head Screwdriver to remove the belt access door. (There is a slot at the end of the door.) Pull the Belt Access Door up and out.

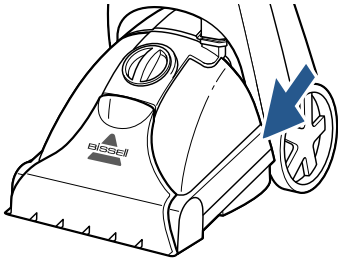

2

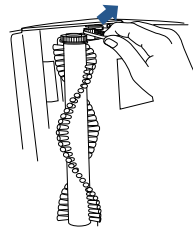

Turn the machine to lay on its side so the belt access area is facing upward. Use a Philips screwdriver to remove the screws on the arms that hold the brush in place. If the Brush Belt is broken, gently remove the belt. To re-install a new belt, first place the belt around the pulley and then stretch it to wrap around the brush gear.

3

### Pump Belt

Pictured here is the Pump Belt. If broken, gently remove the belt. To re-install a new Pump Belt, loop one end of the new belt around the red pump pulley and then stretch it to the silver motor shaft.

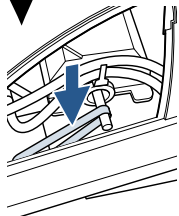

4

To return the Belt Access Door, line it up with the slots in the machine. The door will slide into place and snap shut.

# Troubleshooting

## WARNING

To reduce the risk of electric shock, turn power switch OFF and disconnect plug from electrical outlet before performing maintenance or troubleshooting checks.

Problem	Possible causes	Remedies
<b>There is no power to the machine.</b>	The machine power switch is not turned ON ( I ).	Turn on the power switch, this will illuminate the light on the front of the machine.
	Wall outlet may not have power.	Try another working outlet.
<b>Reduced spray or no spray</b>	Bladder may be empty.	Refill bladder with hot tap water.
	2-in-1 Tank may not be seated properly.	Turn power OFF (O); remove & reseal tank.
	Pump may have lost prime.	Turn power OFF and hold the spray trigger for 30 seconds. Turn machine back on and check for spray.
<b>DirtLifter® PowerBrush does not turn</b>	The brush belt or pump belt is OFF or broken.	Refer to instructions on page 10 for Belt Replacement. Please visit <a href="http://bissell.com">bissell.com</a> or call BISSELL Consumer Services at 0344-888-6644. Instructions will accompany the replacement belt.
<b>Machine does not have suction</b>	ReadyTools dial may be on the wrong setting for the cleaning job.	Set ReadyTools dial to the proper setting. If you are using the hose, the dial setting should be "Tools". If you are using the machine as an upright, the dial should be set at "Floor Cleaning".
	Nozzle window may not be properly attached.	Press down firmly on the black oval gasket at the top window to make sure the two tabs on the back of the nozzle window are snapped into the mating slots in the main housing.
	2-in-1 tank lid is not properly installed.	Re-install lid.
	2-in-1 tank is not properly seated.	2-in-1 tank must be firmly seated to function; remove and reseal 2-in-1 tank.
	Poor tool position. (Hand held attachments only).	Adjust angle; apply more downward pressure.
	2-in-1 Tank has picked up maximum dirty water.	Empty 2-in-1 tank, refer to page 9.
<b>ReadyTools dial becomes difficult to turn.</b>	Diverter assembly should be cleaned.	Remove the nozzle (page 9) and remove the diverter assembly; hold it under running water making sure water flows through and around the dial. Turn the dial about 10 times clockwise and 10 times counterclockwise. This should free up debris. Wipe the diverter and nozzle dry and return it to the machine.

# Consumer Guarantee

This Guarantee only applies outside of the USA and Canada. It is provided by BISSELL International Trading Company BV ("BISSELL").

This Guarantee is provided by BISSELL. It gives you specific rights. It is offered as an additional benefit to your rights under law. You also have other rights under law which may vary from country to country. You can find out about your legal rights and remedies by contacting your local consumer advice service. Nothing in this Guarantee will replace or lessen any of your legal rights or remedies. If you need additional instruction regarding this Guarantee or have questions regarding what it may cover, please contact BISSELL Consumer Care or contact your local distributor.

This Guarantee is given to the original purchaser of the product from new and is not transferable. You must be able to evidence the date of purchase in order to claim under this Guarantee.

## Limited 5 Year Guarantee (from the date of purchase by original purchaser)

Subject to the \*EXCEPTIONS AND EXCLUSIONS identified below, BISSELL will repair or replace (with new or remanufactured components or products), at BISSELL's option, free of charge, any defective or malfunctioning part or product.

BISSELL recommends that the original packaging and evidence of the date of purchase be kept for the duration of the Guarantee period in case the need arises within the period to claim on the Guarantee. Keeping the original packaging will assist with any necessary re-packaging and transportation but is not a condition of the Guarantee.

If your product is replaced by BISSELL under this Guarantee, the new item will benefit from the remainder of the term of this Guarantee (calculated from the date of the original purchase). The period of this Guarantee shall not be extended whether or not your product is repaired or replaced.

### \*EXCEPTIONS AND EXCLUSIONS FROM THE TERMS OF THE GUARANTEE

This Guarantee applies to products used for personal domestic use and not commercial or hire purposes. Consumable components such as filters, belts and mop pads, which must be replaced or serviced by the user from time to time, are not covered by this Guarantee.

This Guarantee does not apply to any defect arising from fair wear and tear. Damage or malfunction caused by the user or any third party whether as a result of accident, negligence, abuse, neglect, or any other use not in accordance with the User Guide is not covered by this Guarantee.

An unauthorised repair (or attempted repair) may void this Guarantee whether or not damage has been caused by that repair/attempt.

Removing or tampering with the Product Rating Label on the product or rendering it illegible will void this Guarantee.

SAVE AS SET OUT BELOW BISSELL AND ITS DISTRIBUTORS ARE NOT LIABLE FOR ANY LOSS OR DAMAGE THAT IS NOT FORESEEABLE OR FOR INCIDENTAL OR CONSEQUENTIAL DAMAGES OF ANY NATURE ASSOCIATED WITH THE USE OF THIS PRODUCT INCLUDING WITHOUT LIMITATION LOSS OF PROFIT, LOSS OF BUSINESS, BUSINESS INTERRUPTION, LOSS OF OPPORTUNITY, DISTRESS, INCONVENIENCE OR DISAPPOINTMENT. SAVE AS SET OUT BELOW BISSELL'S LIABILITY WILL NOT EXCEED THE PURCHASE PRICE OF THE PRODUCT.

BISSELL DOES NOT EXCLUDE OR LIMIT IN ANY WAY ITS LIABILITY FOR (A) DEATH OR PERSONAL INJURY CAUSED BY OUR NEGLIGENCE OR THE NEGLIGENCE OF OUR EMPLOYEES, AGENTS OR SUBCONTRACTORS; (B) FRAUD OR FRAUDULENT MISREPRESENTATION; (C) OR FOR ANY OTHER MATTER WHICH CANNOT BE EXCLUDED OR LIMITED UNDER LAW.

## Consumer Care

**If your BISSELL product should require service or to claim under our limited guarantee, please contact us as follows:**

### Website:

[www.BISSELL.com](http://www.BISSELL.com)

### Email:

[info@bisselldirect.co.uk](mailto:info@bisselldirect.co.uk)

### Telephone:

0344-888-6644

### Write:

BISSELL Homecare (Overseas) Inc.  
Ground Floor  
226 Berwick Avenue  
Slough, Berkshire, SL1 4QT  
United Kingdom

## Visit the BISSELL website: [www.BISSELL.com](http://www.BISSELL.com)

When contacting BISSELL, have model number of cleaner available.

Please record your Model Number: \_\_\_\_\_ Please record your Purchase Date: \_\_\_\_\_

**NOTE: Please keep your original sales receipt. It provides proof of the date of purchase in the event of a Guarantee claim. See Guarantee for details.**



©2017 BISSELL Homecare, Inc.  
Grand Rapids, Michigan  
All rights reserved. Printed in China  
Part Number 161-2923 07/17  
Visit our website at: [www.BISSELL.com](http://www.BISSELL.com)