



**SPEAR &
JACKSON**

ORIGINAL INSTRUCTION MANUAL

3000W

Electric Blower & Vac

GY8900



**Important - Please read these instructions
fully before starting assembly**

These instructions contain important information that will help you get the best from your blower & vac, ensuring it is assembled correctly and safely. If you need help or have damaged or missing parts, call the Customer Helpline on 0345 605 2067

**AFTER SALES SUPPORT
0345 605 2067**

SPEAR & JACKSON SINCE 1760

For more than 250 years gardeners have enjoyed high quality performance and great results using Spear & Jackson tools.

Our garden power tools combine continuous innovation and the latest in manufacturing technologies with a proud heritage.

Each product is carefully designed with performance, comfort and durability firmly in mind, which has earned Spear & Jackson an enviable reputation as a maker of tools to trust.

3 YEARS GUARANTEE

As a testament to the quality of our products, we offer a 3 year manufacturers warranty and a comprehensive after sales service.

The warranty covers manufacturing faults, however in the event that the item has been deliberately damaged, used in a commercial environment or disassembled then the warranty will be null and void.

Please retain proof of purchase.

7 DAYS A WEEK TECHNICAL SUPPORT

We want you to get the best out of your products. Our easy-to-read instruction manual guides you with best practice use and maintenance tips. Please call **0345 605 2067** for technical support, we can solve around 80% of questions directly over the phone.

We hope you enjoy your product and we look forward to any feedback, as this allows us to develop even better products for the future.

CONTENTS

Safety Information	4
Description of symbols	4
General safety	5
Personal safety	5
Operating safety	6
Maintenance and storage safety	10
Intended use	10
Box Content / Parts	12
Assemble	13
Height adjustment	13
Shoulder strap installation	13
Fitting the collection bag	13
Front handle adjustment	14
Rake adjustment	14
Operate	15
Before starting	15
Starting the blower & vac	15
Stopping the blower & vac	15
Using the blower mode	16
Using the vacuum mode	17
Rake function	17
Maintenance	18
Cleaning debris	18
Storing Your Product	18
Maintenance	19
Disposing of the machine	19
Disposing of the packaging	19
Technical Data	20
Troubleshooting	22
Warranty	23

SAFETY INFORMATION

Please read these instructions fully before operating or maintaining your machine

DESCRIPTION OF SYMBOLS

The following warning symbols appear throughout this manual and indicate the appropriate safety measures you should take when operating and maintaining the blower & vac.



IMPORTANT!

Please read all of the safety and operating instructions carefully before using this tool. Please pay particular attention to all sections of this user guide that carry warning symbols and notices.



WARNING!

This is a warning symbol. This symbol is used throughout the user guide whenever there is a risk of personal injury. Ensure that these warnings are read and understood at all times.



Wear eye and ear protections.



Warning! Flying objects



Vacuum mode



Blower mode



Wear gloves to protect your hands



Rotating impeller blades can cause serious injury



Keep bystanders away



Danger-rotating blades



Do not expose to rain



Switch off and unplug the device before cleaning or performing maintenance on it



The product complies with the applicable European directives and an evaluation method of conformity for these directives was done.



Guaranteed sound power level.

SAFETY INFORMATION

Please read these instructions fully before operating or maintaining your machine

GENERAL SAFETY



IMPORTANT!

- Keep this instruction manual in a safe place for future reference.
- Read the instructions carefully. Be familiar with the controls and the proper use of the equipment.
- Never allow children or people unfamiliar with these instructions to use the blower&vac. Local regulations can restrict the age of the operator.
- Never use the machine while people, especially children, or pets are nearby. Keep in mind that the operator or user is responsible for accidents or hazards occurring to other people or their property.
- This appliance is not intended for use by persons (including children) with reduced

physical, sensory or mental capabilities, or lack of experience and knowledge, unless they have been given supervision or instruction concerning use of the appliance by a person responsible for their safety.

- Don't use the appliance without reading the instruction sheet.
- Children should be supervised to ensure that they do not play with the appliance.

PERSONAL SAFETY

- Stay alert, watch what you are doing and use common sense when operating a power tool. Do not use a power tool when you are tired or under the influence of drugs, alcohol or medication. A moment of inattention when operating a power tool may result in serious

SAFETY INFORMATION

Please read these instructions fully before operating or maintaining your machine

personal injury.

- Use safety equipment. Always wear eye protection. Using safety equipment such as a dust mask, nonskid safety shoes, a hard hat, or hearing protection whenever it is needed will reduce the risk of personal injury.
- Avoid accidental starts. Ensure the switch is in the off position before inserting the plug. Carrying power tools with your finger on the switch or plugging in power tools when the switch is in the on position makes accidents more likely.
- Remove any adjusting keys or spanners before turning on the power tool. A spanner or key left attached to a rotating part of the power tool may result in personal injury.
- Do not reach out too far. Keep your feet firmly on

the ground at all times. This will enable you retain control over the power tool in unexpected situations.

- Dress properly. Do not wear loose clothing or jewellery. Keep your hair, clothing and gloves away from the power tool. Loose clothes, jewellery or long hair can become entangled in the moving parts.
- If there are devices for connecting dust extraction and collection facilities, please ensure that they are attached and used correctly. Using such devices can reduce dust-related hazards.

OPERATING SAFETY

Working area

- Keep working area clean and well lit. Untidy and dark areas can lead to accidents.
- Do not operate power

SAFETY INFORMATION

Please read these instructions fully before operating or maintaining your machine

tools in potentially explosive surroundings, for example, in the presence of inflammable liquids, gases or dust. Power tools create sparks which may ignite the dust or fumes.

- A leaf blower is not intended for wet conditions! Avoid wet materials such as leaves and dirt, twigs, branches, pine needles, grass, earth, sand, mulch, cuttings, etc. Do not use on wet lawns, grass areas or fields. Misuse may lead to congestion in the shredding unit and lead to reduced functionality. The machine may need to be completely dismantled and cleaned. This work should be carried out by a qualified service technician and is not covered by warranty.

Electrical safety

- Always check that the power supply corresponds to the voltage on the rating plate.
- Power tool plugs must match the outlet. Never modify the plug in any way. Do not use adapter plugs with earthed power tools. Unmodified plugs and matching outlets will reduce the risk of an electric shock.
- Avoid body contact with earthed surfaces such as pipes, radiators, kitchen ranges and refrigerators. There is an increased risk of an electric shock if your body is earthed.
- Do not expose power tools to rain or wet conditions. If water gets inside a power tool, it will increase the risk of an electric shock.
- Do not damage the cord. Never use the cord for carrying, pulling or unplugging the power tool. Keep the cord away from heat, oil, sharp edges or moving parts. Damaged or entangled cords increase

SAFETY INFORMATION

Please read these instructions fully before operating or maintaining your machine

the risk of an electric shock.

- When operating a power tool outdoors, use an extension cable suitable for outdoor use. Using a cord suitable for outdoor use reduces the risk of an electric shock.
- If operating a power tool in a damp location is unavoidable, use a power supply protected by a residual current device (RCD). Using an RCD reduces the risk of an electric shock.

Power tool use and care

- Only use the tool in the context it was designed for.
- Do not use the power tool if the switch cannot turn it on and off. A power tool with a broken switch is dangerous and must be repaired.
- Disconnect the plug from

the power source before making adjustments, changing accessories, or storing power tools. Such preventive safety measures reduce the risk of starting the power tool accidentally.

MACHINE SAFETY WARNINGS

- Always direct the cable to the rear, away from the appliance.
- If a cord becomes damaged during use, disconnect the supply cord from the mains supply immediately.
- Operate the appliance only in daylight or in good artificial light.
- Walk, never run when using appliance.
- Keep all cooling air inlets clear.
- Do not attempt to modify the power tool in any way. The use of any attachment or accessory other than those recommended in this

SAFETY INFORMATION

Please read these instructions fully before operating or maintaining your machine

instruction manual could result in damage to the power tool and injury to the operator.

- Never feed hard objects such as stones, bottles, cans or pieces of metal into the Blower & Vac. They can cause damage to the machine and possibly injury to the operator and bystanders.
- If a foreign body, or other debris, is accidentally collected by the Blower & Vac, stop it immediately and do not use the Blower & Vac until it has been checked and you are sure that the entire Blower & Vac is in a safe operating condition.
- If the Blower & Vac makes any unusual noise or starts to vibrate abnormally STOP immediately remove the plug from the mains supply and investigate the cause. Excessive vibration can cause damage to the Blower & Vac and injury to

the operator.

- Never operate the appliance while people, especially children, or pets are nearby.
- The operator or user is responsible for accidents or hazards occurring to other people or their property.
- Before use always check the appliance including supply and extension cord for signs of damage and aging.
- Never operate the appliance with defective guards or shields, or without safety devices, for example debris collector in place.
- The device must not be employed in areas where there is health endangering dusts or as a wet suction device.

SAFETY INFORMATION

Please read these instructions fully before operating or maintaining your machine

MAINTENANCE AND STORAGE SAFETY



WARNING!

- To ensure appliance safety, use only original spare parts from the manufacturer or approved by the manufacturer.
- Retrofitting or making any unauthorized changes to the machine, as well as the use of unapproved parts will invalidate your warranty.
- Do not attempt to repair the equipment yourself. All work not indicated in these instructions is to be carried out only by service stations authorized by us.
- Store the equipment in a dry location and when not in use, out of the reach of children and do not allow people who are not familiar with the equipment or these instructions to operate it. Equipment is potentially

dangerous in the hands of untrained users.

- Handle the equipment with care. Keep the equipment clean for safe and more efficient working. Follow the maintenance directions.
- Check for misalignment, jammed moving parts, breakages or any other feature that might affect the operation of the machine. If it is damaged, the equipment must be repaired. Many accidents are caused by using poorly maintained machines.

INTENDED USE

This Blower & Vac is designed for domestic use only:

- The device is designed only for blowing and suction of light DRY debris, such as leaves, grass, mulch and clippings, from

SAFETY INFORMATION

Please read these instructions fully before operating or maintaining your machine

domestic gardens. Avoid wet materials, as it may lead to congestion in the shredder unit and lead to reduced functionality. Every other utilization, which is not explicitly approved in these directions, can lead to damage to the device and represents a serious danger to the user.

- To use with accessories, replacement parts and detergents approved by Spear & Jackson.

Any use of the machine that deviates from its intended use and is not included in these instructions is considered unauthorized use and relieves the manufacturer from his or her legal liability.

BOX CONTENT

PARTS

- | | | | |
|---|-------------------------|----|----------------------------|
| 1 | Shoulder strap x1 | 9 | Adjustable front handle |
| 2 | On/off trigger | 10 | Speed controller |
| 3 | Impeller access release | 11 | Angle adjusting button |
| 4 | Collection bag holder | 12 | Vacuum/Blow selector lever |
| 5 | Collection bag | 13 | Wheel |
| 6 | Vacuum/Blower tube | 14 | Rake knob |
| 7 | Operate manual | 15 | Rake |
| 8 | Hook | | |

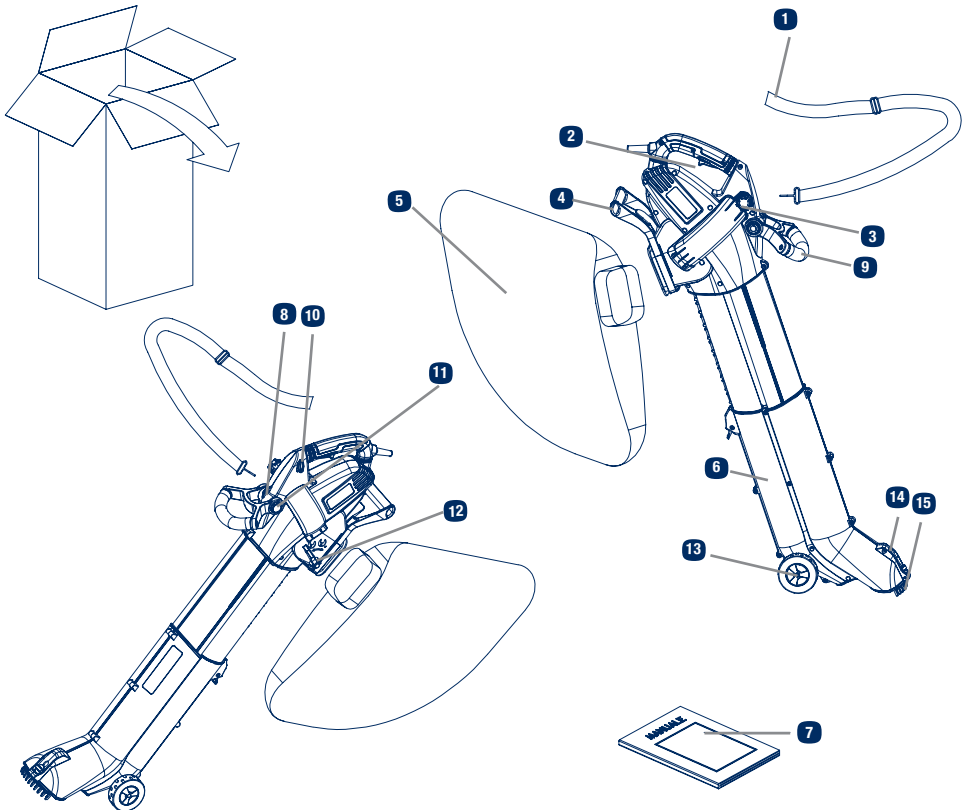

If there are any parts missing, please call the customer helpline on 0345 605 2067
Please store the packaging in a safe place for warranty purposes.

ASSEMBLE



WARNING: Always switch off tool and unplug from outlet before removing vacuum bag for emptying.

1 HEIGHT ADJUSTMENT

Press the height adjusting button (A) and slide the Vacuum/Blower tube (B) to desired length. It can be extended up to 300mm.

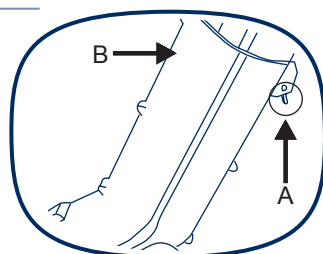

2 SHOULDER STRAP INSTALLATION

Attach the strap clip to the top of main body. With machine on operation's right hand side, place shoulder strap across chest and over left shoulder.

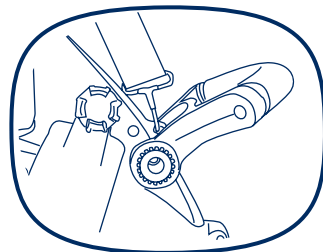

3 FITTING THE COLLECTION BAG

To install the collection bag, insert the buckle of support frame into the slot of the housing. Frame will click into position when properly fitted.

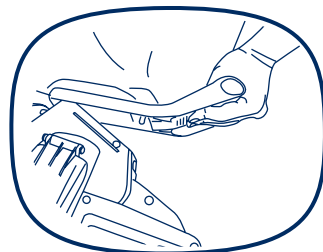

ASSEMBLE

To dismantle the collection bag:

Press the spring lever to release the bag.

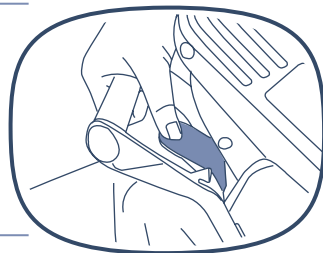

4 FRONT HANDLE ADJUSTMENT

Adjust the front handle to a comfortable angle. Press the adjusting buttons at both sides(A) and rotate the handle to desired position.

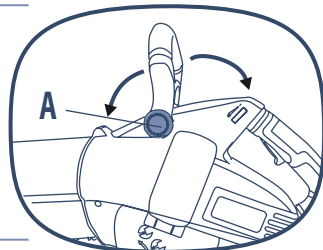

5 RAKE ADJUSTMENT

Rotate the rake knob 90° anticlockwise and then the rake will automatically pop-up. Lock the knob by rotating 90° clockwise.

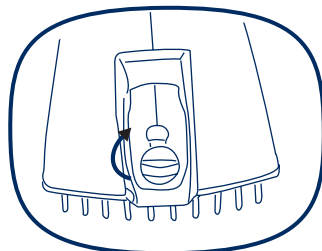
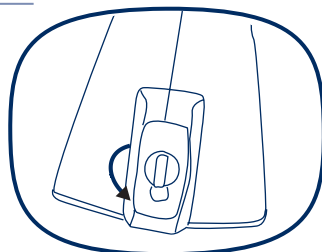

OPERATE

Before starting

1. Ensure the Blower & Vac tube is fitted correctly and attach the collection bag. Without the collection bag assembled, you cannot start the Blower & Vac.
2. Plug the Blower & Vac into the mains supply and switch on.

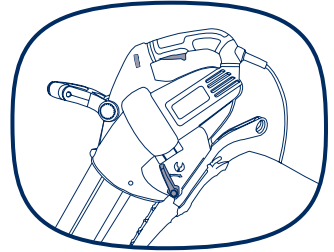

WARNING: Before selecting either Vacuum or Blower function ensure that the selector lever operates smoothly and that it is not obstructed by debris from the previous use.

More information check P16

Starting the Blower & Vac

Select either the Vacuum or Blower function using the selector lever (A) on the side of the machine and press the on/off trigger (B). If more power is required, slide the speed controller from position "1" to position "max" (C).

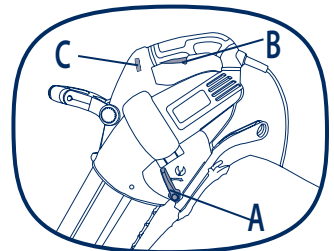

Stopping the Blower & Vac

To turn off the machine you can simply release the On/off trigger.

OPERATE



WARNING: Any hard objects, such as stones, tin cans glass etc, will damage the suction fan.

Do not use the Blower/Vacuum/Shredder to suck up water or very wet debris.

Never operate the Blower/Vacuum/Shredder without the debris collection bag fitted.

Using the blower mode

Select the blow function using the selector lever on the side of the machine and switch on. With the Blower & Vac resting on its wheels, move it forward directing the nozzle at the debris to be cleared.

Adjust the speed with the speed control button if more power is required.

Alternatively hold nozzle just above the ground and swing the machine from side to side. Moving forward and direct the nozzle at the debris to be cleared. Blow the debris into a convenient heap then use the vacuum function to collect the debris.

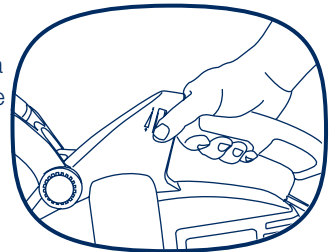
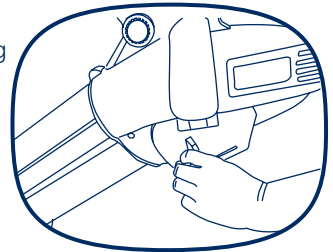

Vacuum mode(A)

Blower mode(B)

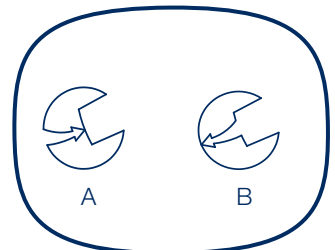

OPERATE

Using the Vacuum mode

Inspect the area to be worked before starting. Remove any objects or debris that could be thrown, jammed or become entangled in the Blower & Vac.

Inspect the area to be worked before starting. Remove any objects or debris that could be thrown, jammed or become entangled in the Blower & Vac. Select the vacuum function using the selector lever on the side of the machine and switch on.

With the Blower & Vac resting on its wheels move the Blower & Vac forwards directing the nozzle at the debris to be collected. Alternatively with the Blower & Vac held just above the ground swing the machine from side to side, moving forwards and directing the nozzle at the debris to be collected. Do not force the nozzle into the debris as this will block the suction tube and reduce the efficiency of the machine.

Adjust the speed with the speed control button if more power is required.

Clearing the impeller from debris add warning (unplug the machine before clearing the impeller, use gloves)

Unscrew the knob of the impeller access door.
Wearing gloves, carefully clear the impeller from debris
Close the access door and hand tighten the screw, no force is needed.

Organic materials such as leaves contain a large amount of water that can cause them to stick to the inside of the suction tube. To reduce sticking the material should be left for a few days to dry out.

Rake function

The integrated rake will help to loosen debris between gravel.

MAINTENANCE



WARNING: Never use water for cleaning your product, use only a dry cloth. Do not clean with chemicals or solvents, some can destroy critical plastic parts.

Always wear gloves to remove debris from this product

Cleaning debris

1. Switch off and disconnect from the mains electricity supply before cleaning your product.
2. Always empty the collection bag, using the zip.
3. Unscrew the Impellor access release (3) anti-clockwise, until the door opens.
4. Wearing gloves, carefully rotate the fan and remove debris by hand. Clean the fan with a soft brush ensuring it is free from debris
5. Clean the tube with a soft brush or cloth.
6. Close up the motor housing unit by tightening the impellor access release screw until secure (do not overtighten).
7. Clean the air vents with a soft brush
8. Turn over the product and carefully check the tube for debris.
9. Refit the collection bag.

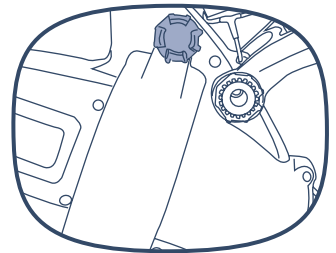

Storing Your Product

Always store the product in a dry place ensuring the cable is not likely to be damaged on sharp edges etc.

MAINTENANCE

Maintenance

Our machines have been designed to operate over a long period of time with a minimum of maintenance. Continuous satisfactory operation depends upon proper machine care and regular cleaning.

Keep all nuts, bolts and screws tight to be sure the appliance is in safe working condition.

1. Check the collection bag frequently for wear or deterioration.
2. Replace worn or damaged parts.
3. Use only genuine replacement parts and accessories.
4. Store the appliance only in a dry place.

Disposal of the machine

Machines which are labelled with the this symbol must not be disposed of in household rubbish. You must dispose of such old electrical and electronic appliances separately.

Please check with your local authority about the possibilities for correct disposal. You will thus help to avoid that damaging into the environment.

Disposing of the packaging

The packaging consists of cardboard and correspondingly marked sheets that can be recycled. Make these materials available for recycling.



TECHNICAL DATA

Model	GY8900
Rated Voltage	230 -240V~/50Hz
Rated Power	3000W
No-Load Speed	11500-15500 /min
Capacity Of Collection Bag	45L
Tube Length	47-75cm
Air Speed	100-300km/h
Volume	10-16m ³ /min

Part number	Accessories
8047-870001	shoulder strap
8045-872001	collection bag
8058-880001	access door screw

TECHNICAL DATA

Measured sound pressure level L_{pA} :90.8dB(A), $K=3$ dB(A)

Measured sound power level L_{wA} :102.3 dB(A), $K=2.1$ dB(A)

Guaranteed sound power level L_{wA} :104dB(A)

The following information :

-That declared vibration total value has been measured in accordance with a standard test method and may be used for comparing one tool with another.

-That declared vibration total value may also be used in a preliminary assessment of exposure.



WARNING:

-The vibration emission during actual use of the power tool can differ from the declared total value depending on the ways in which the tool is used.

-Of the need to identify safety measures to protect the operator that are based on an estimation of exposure in the actual conditions of use(taking account of all parts of the operating cycle such as the times when the tool is switched off and when it is running idle in addition to the trigger time).

Noise and vibration values were determined according to the standards and stipulations mentioned in the declaration of conformity. Technical and optical changes can be carried out in the course of further development without notice. All dimensions, references and information of this instruction manual are therefore without guarantee. Legal claims, which are made on the basis of the instruction manual, cannot thus be considered as valid.

TROUBLESHOOTING

Problem	Possible cause	Solution
Device does not start	Collection bag is not fitted	Install the collection bag,
	Mains voltage is not present	Check plug socket, cable, line, plug and fuse, where appropriate, repair through electrical specialist
	Defective on/off switch	Repair through customer service
	Worn carbon brushes	
	Defective motor	
Impeller fan cover still open	Close impeller fan cover and screw it down properly	
Device works with interruptions	Damaged power cable	Check cable; call service helpline
	Internal loose connection	Repair through customer service
	Defective on/off switch	
Low suction capacity or suction not present	Collection bag (5) is full	Empty collection bag
	Collection bag is dirty	Clean collection bag
	Selector switch (12) is in the wrong position	Set selector switch to the suction symbol 
	Device clogged up or blocked by foreign bodies	Remove blockages (see chapter Cleaning and Maintenance)
Small or missing blowing power	Selector switch (12) in incorrect position	Set selector switch to the blowing symbol 
	Speed controller (10) in wrong position	Rotate speed controller to high position
Device works with interruptions	Foreign body blocks impeller wheel	Remove blockage (see chapter Cleaning and Maintenance)

WARRANTY

If your device develops a fault, please don't hesitate to contact our customer service department on 0345 605 2067, we can solve 80% of problems via the phone.

1. These warranty terms cover additional warranty rights and do not affect your statutory warranty rights. All our products are covered by a 3 year manufacturer warranty.
2. Claims must be accompanied by proof of purchase. This must be in the form of a sales receipt or bank statement and must show that the product has been purchased within the warranty period as described under point 1, from the retailer that it was originally bought from. Please keep your receipt safe or staple it to the back of this manual for future reference.
3. Our warranty covers problems caused by material or manufacturing defects, and will result in the repair of these defects or replacement of the device with a like for like or similar article.
4. Our devices have not been designed for commercial, trade or industrial applications, any signs of use of the equipment in these application or equivalent activities, invalidates the warranty.
5. The following are also excluded from our warranty:
 - A. Faults due to accidents, customer misuse or unauthorized repairs
 - B. Consumable Parts such as cutting line, plant protectors, handles, knobs, extension cable and other accessories that are compatible with the product.
 - C. Failure due to lack of routine maintenance.
 - D. Failure as a result of not using the equipment in accordance with the manual and safety instructions
 - E. The adjustment of cables

Warranty claims should be submitted before the end of the warranty period, see point 1, but a paid service exists for repairs commissioned after this period. The original warranty period remains applicable to the device even if repairs are carried out or parts are replaced. In such cases, the work performed or parts fitted will not result in an extension of the warranty period, and no new warranty will become active for the work performed or parts fitted.

If you have any problems or questions concerning your garden power tool, please contact our after sales service at 0345 605 2067.