

# Canterbury 4 DR 2 DRW ROBE

Assembly Instructions - Please save for future reference

737/8876

724/5882

736/6503

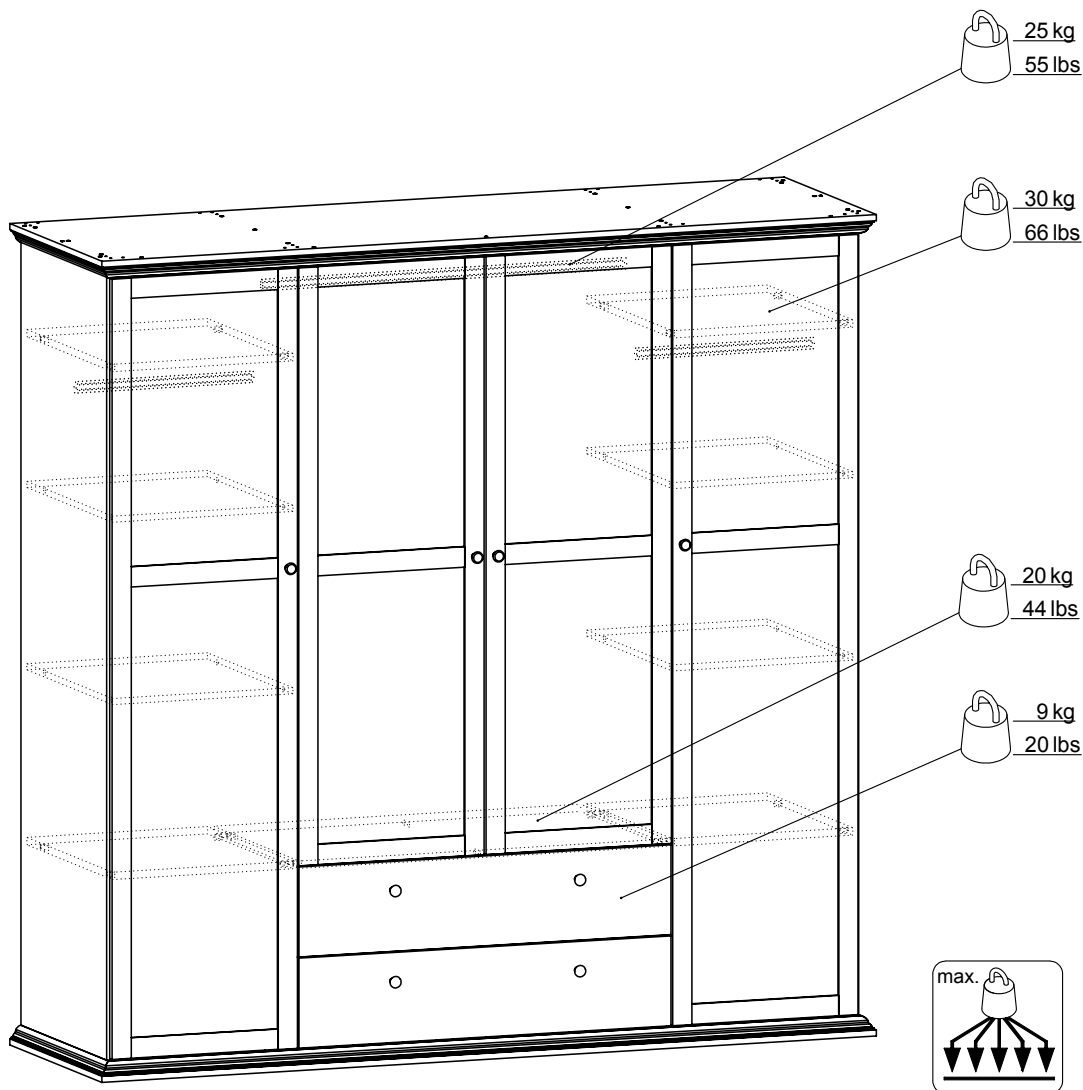

## Dimensions

Width: 201.3cm

Depth: 62.7cm

Height: 202.1cm

**Important – Please read these instructions carefully before starting the assembly**

If you need help or have damaged or missing parts, call the **Customer Helpline:**

**Argos = 0345 6400800**



# Safety and Care Advice

**Important – Please read these instructions carefully before starting the assembly**

- Check that you have all the components and tools listed on the following pages.
- Remove all fittings from the plastic bags and separate them into their groups.
- Keep children and animals away from the work area - small parts can choke if swallowed.
- Make sure you have enough space to lay out the parts before starting.

- During assembly, do not stand or put weight on the product, this could cause damage.
- Assemble the item as close to its intended placement (in the same room) as possible.
- Assemble on a soft level surface to avoid damaging the unit or your floor.
- Parts of the assembly will be easier with 2 people to complete.

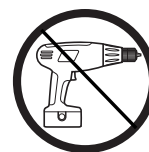

- We do not recommend the use of power drivers for inserting screws, as this could damage the unit. Please only use hand screw drivers.

## Care and maintenance

- Only clean the unit using a damp cloth and mild detergent. Do not use bleach or abrasive cleaners.
- From time to time, check to see if screws have become loose. If so, please tighten them again.
- This product should not be discarded with household waste. Take to your local authority waste disposal centre.

## Safety

- The provided tip-over restraint must be installed in order to ensure user safety.

**Note:** If required, the next page can be cut out and used as reference throughout the assembly. Keep this page with these instructions for future reference.

# Components - Panels

If you have damaged or missing components, call the Customer Helpline: Argos = 0345 6400800



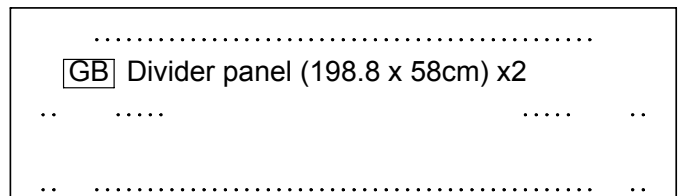
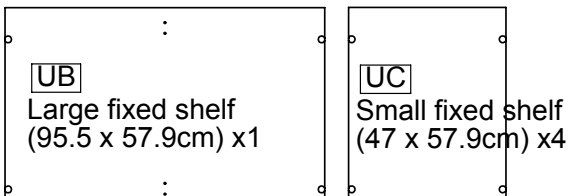
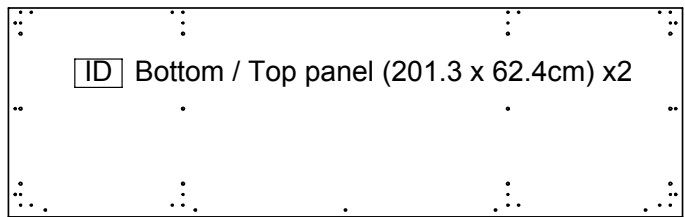
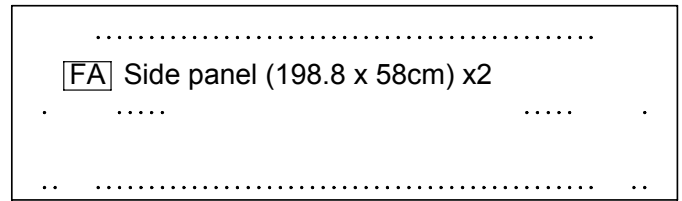
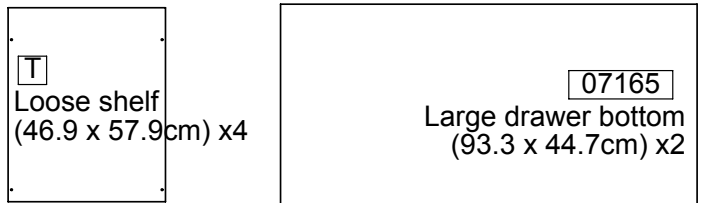
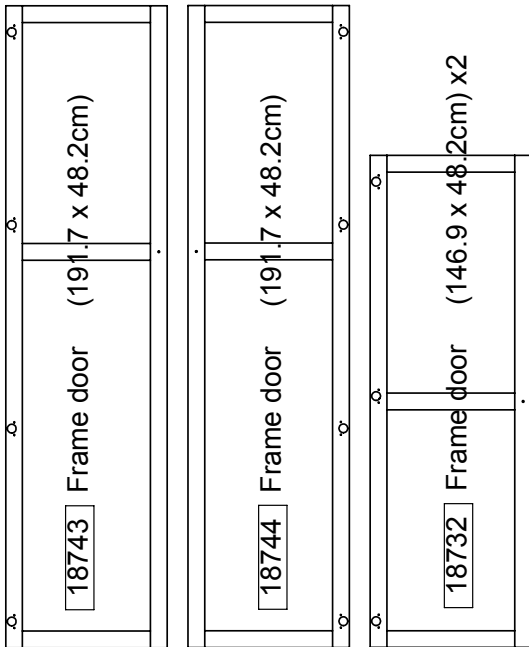
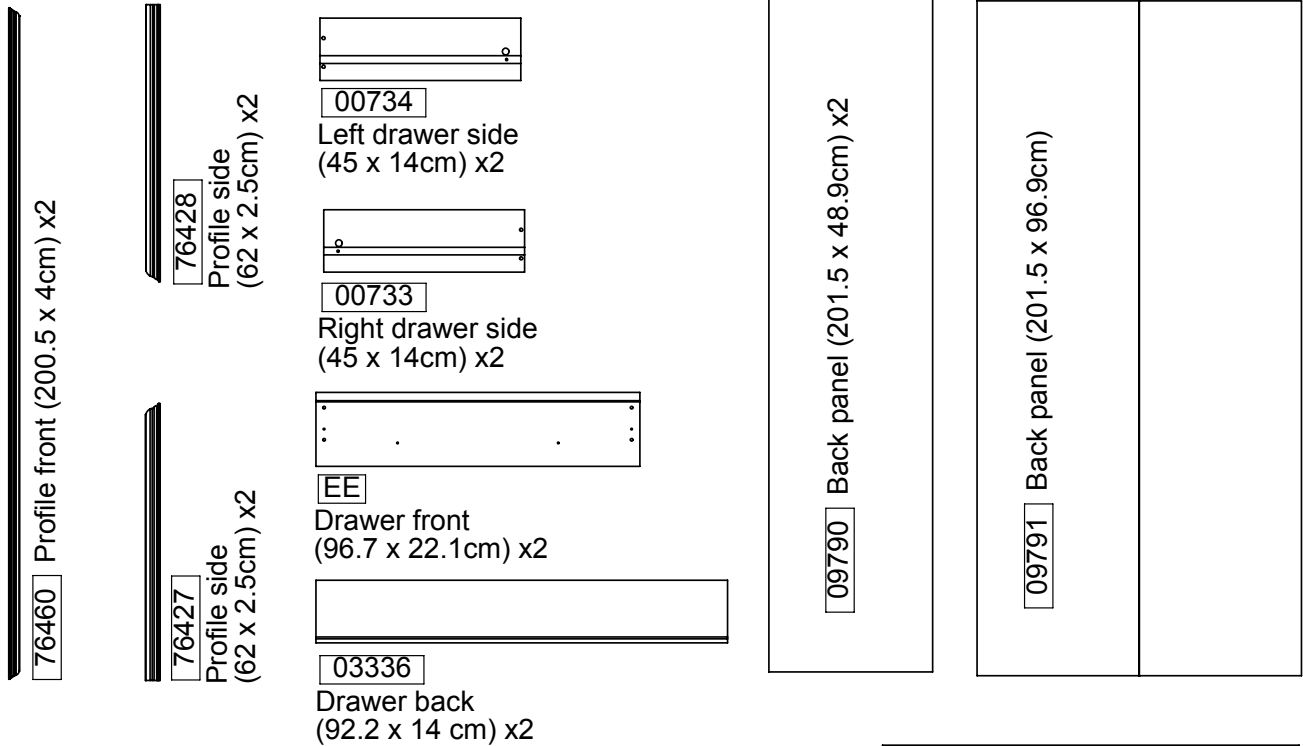







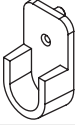
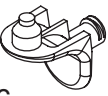

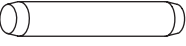
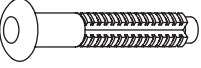
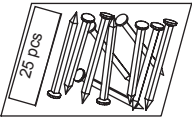
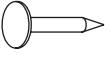

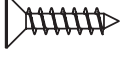





Please check that you have all the panels as listed below

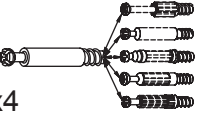

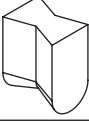
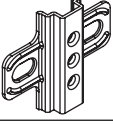
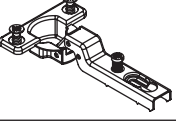
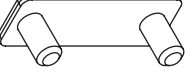
# Components - Fittings

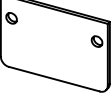
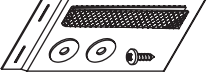
Please check that you have all of the fittings listed below

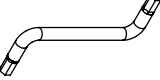
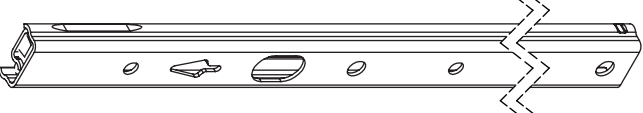
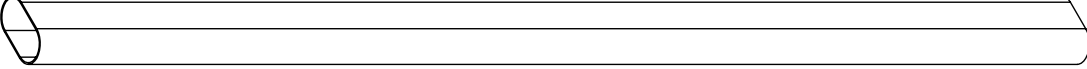
**Note:** The quantities listed in the following are the correct amount to complete the assembly. In some cases, more fittings may be supplied than required.

<b>10601</b> Holder x6 	<b>11042</b> Shelf support x16 	<b>11229</b> Bracket x20 	<b>11230</b> Screw (ø5 x 7.5mm) x20 
<b>20203</b> Dowel (ø5 x 30mm) x24 	<b>20228</b> Drawer fastener x8 	<b>23006</b> Nail x4 	<b>23010</b> Big nail x36 
<b>25215</b> Flat head screw (ø3 x 12mm) x6 	<b>25233</b> Flat head screw (ø3.5 x 15mm) x4 	<b>25440</b> Screw (ø4 x 13mm) x8 	<b>25610</b> Connector bolt (ø7 x 50mm) x24 
<b>26020</b> Flat head screw (ø5.8 x 9mm) x8 	<b>26033</b> Flat head screw (ø6.3 x 27mm) x22 	<b>26071</b> Screw (ø7 x 8mm) x28 	<b>26211</b> Machine screw (M4 x 7mm) x14 
<b>26214</b> Machine screw (M4 x 9mm) x4 	<b>26232</b> Machine screw (M4 x 23mm) x8 	<b>31513</b> Cam bolt x4 	<b>31687</b> Cam x4 
<b>33204</b> Wedges x4 	<b>50491</b> Hinge plate x14 	<b>52291</b> Hinge x14 	<b>63008</b> Floor glider x8 
<b>81040</b> Handle x8 	<b>91410</b> Lock bracket x1 	<b>94009</b> Strap x2 	<b>96203</b> Stop x8 
<b>97642</b> Allen key x1 	<b>41421</b> Drawer runner x4 		
<b>72501</b> Hanger x2 			
<b>72509</b> Hanger x1 			
<b>10503</b> Drawer bottom support x2 			

## Tools required

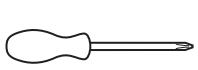

Cross head screwdriver  
(medium & large)



Wooden block

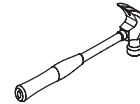

Hammer



Flathead screwdriver  
(medium)

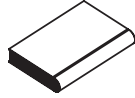

Books X6



Eye protection  
(when using a  
hammer or glue)

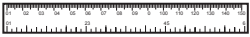

Ruler

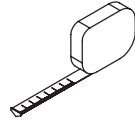

Tape measure

## Ruler - Use this ruler to help correctly identify the screws



# Assembly Instructions

## Step 1

### Insert dowels

Insert dowels **20203** into outer holes on the ends of side panel **FA** and **GB**.

On **FA**, attach holders **10601** while using flat head screws **25215**.

Fittings you will need for this step:

Dowel #20203 x16      Holder #10601 x2      Flat head screw #25215 x2

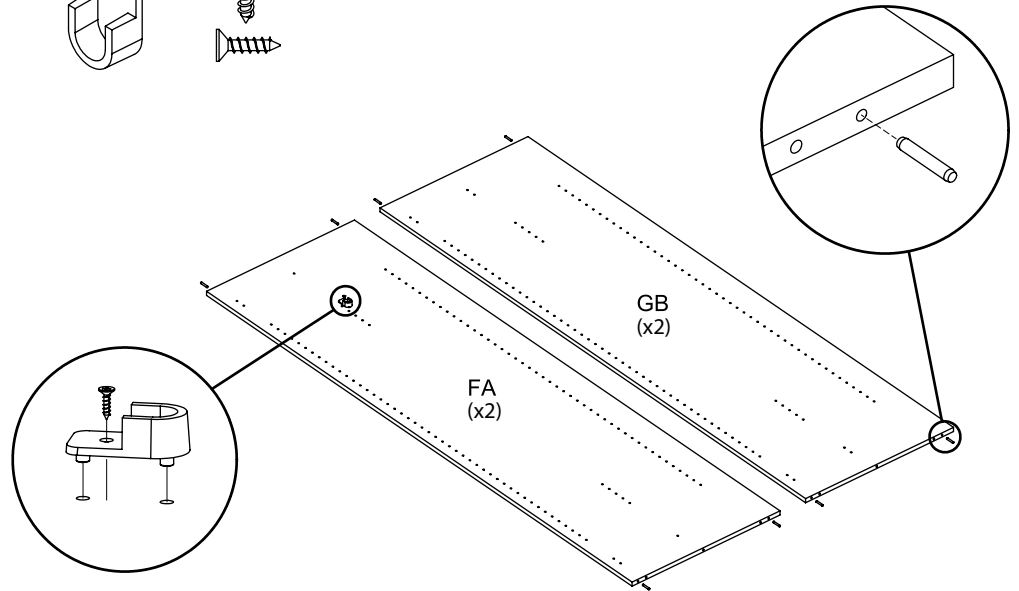
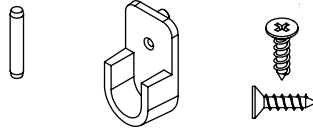

## Step 2

### Attach holders

Attach holders **10601** with flat head screws **25215** on the divide panels **GB**.

Please note where to place the holders on the sides of the panels respectively.

Fittings you will need for this step:

Holder #10601 x4      Flat head screw #25215 x4

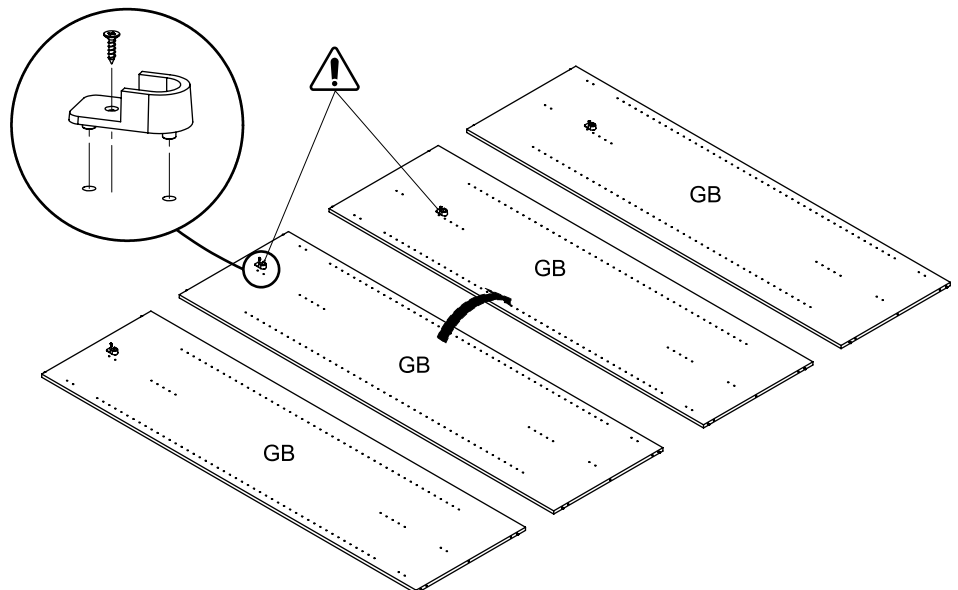
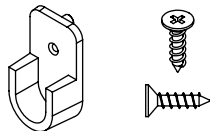

# Assembly Instructions

## Step 3

### Attach hinge plates

Fixate each hinge plate **50491** with screws **26071**.

Insert machine screws **26211** in the center of the hinge plates.

Please note in which hole rows to place the hinge plates when mounting on the panels.

Fittings you will need for this step:

Screw  
#26071 x28



Machine screw  
#26211 x14



Hinge plate  
#50491 x14

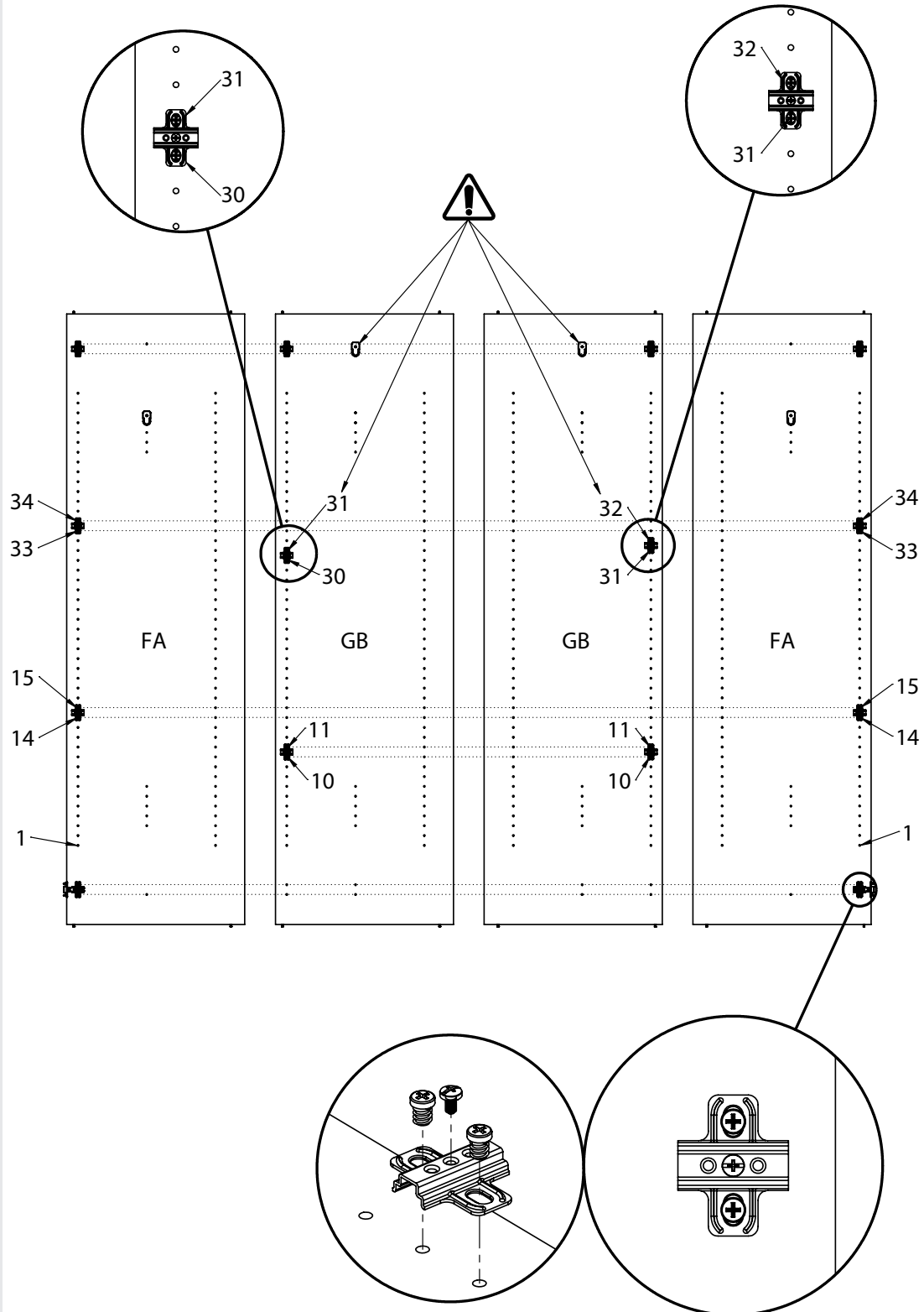
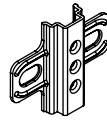

# Assembly Instructions

## Step 4

Attach 4 screws **11230** on one side of both divider panels **GB**. Then turn both divider panels over and attach 2 screws **11230** on each of the other sides.

Please note the hole rows as pictured for correct assembly.

Fittings you will need for this step:

Screw  
#11230 x12

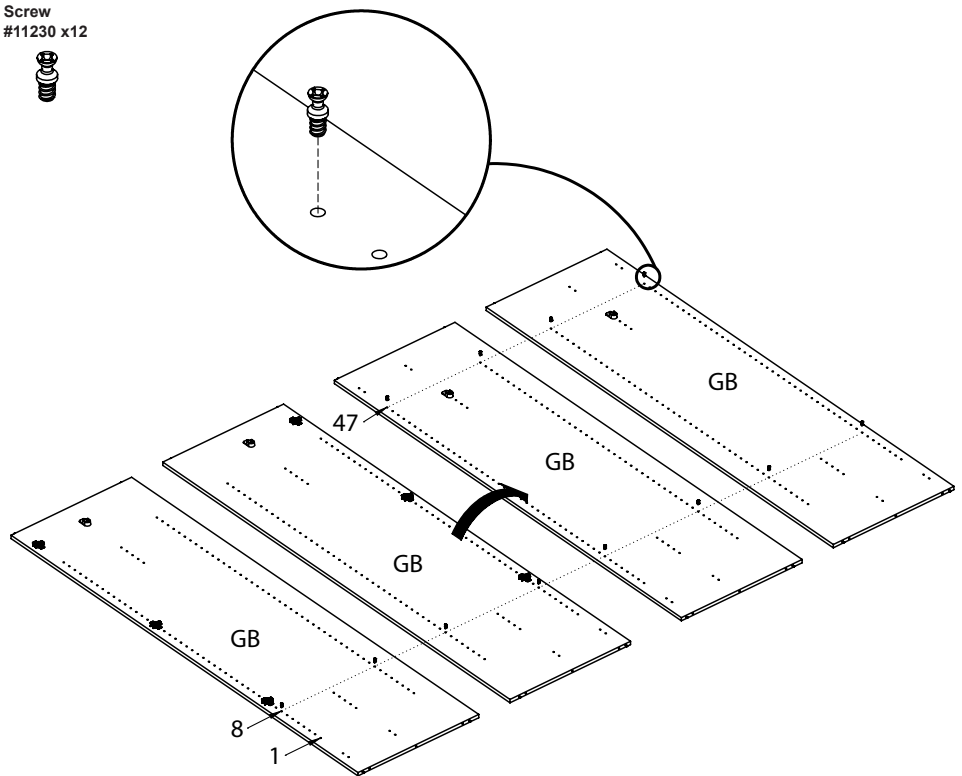

## Step 5

Attach 4 screws **11230** on each side panel **FA**.

Fittings you will need for this step:

Screw  
#11230 x8

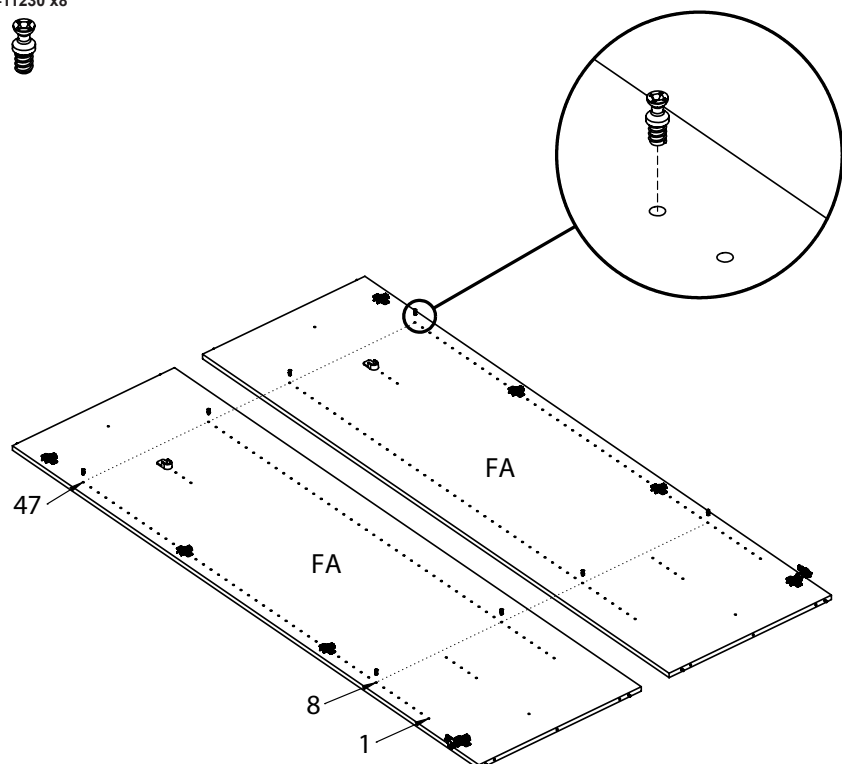



# Assembly Instructions

## Step 6

### Mount drawer runners

1.

Extend drawer runner

**41434**.

2.

Attach the drawer runners at the fronts of divider panels **GB**.

Place flat head screws **25233** and **26020** into the correct holes as displayed at the bottom of this page, into the divider panels **GB**.

Please note the hole rows in which to place the drawer runners.

OBS: Tighten the screws but do not overtighten.

Fittings you will need for this step:

Flat head screw  
#25233 x4



Flat head screw  
#26020 x8



Drawer runner  
#41434 x4

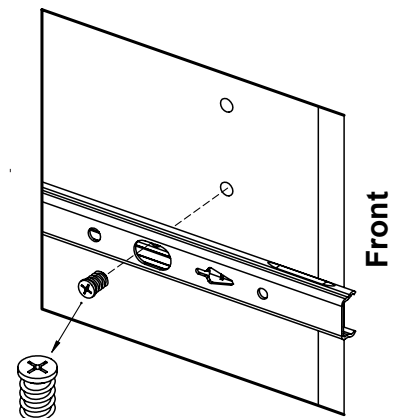
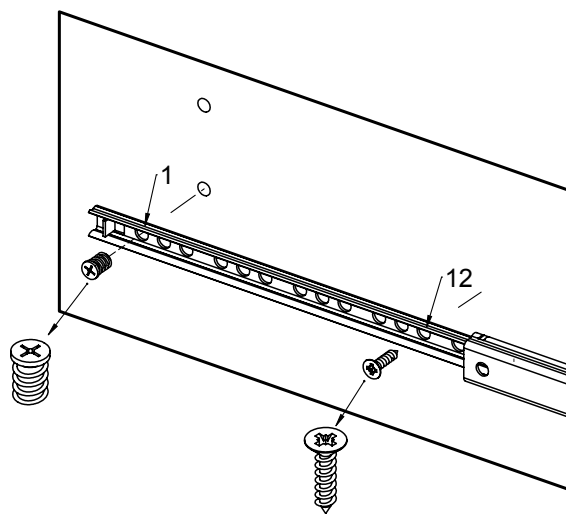
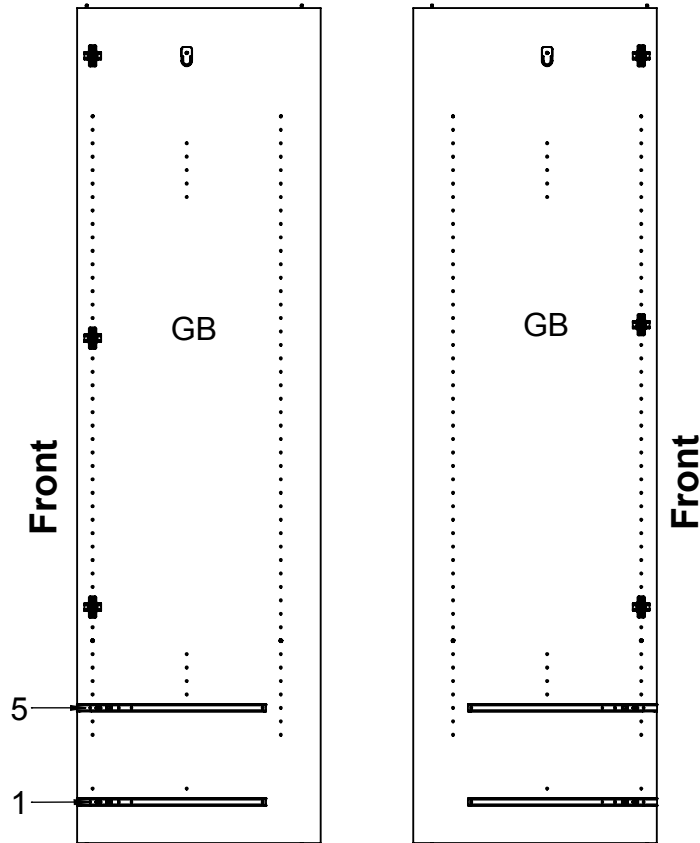
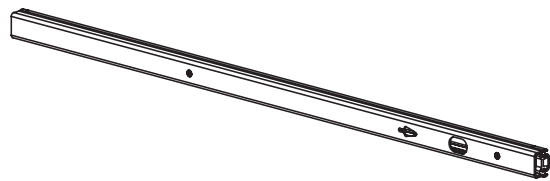

# Assembly Instructions

## Step 7

### Gathering profiles

Insert wedges **33204** into the slots in the angle ends of side profile **B** + **C**, and front profile **A**.

Please use a hammer for this assembly step.

Fittings you will need for this step:

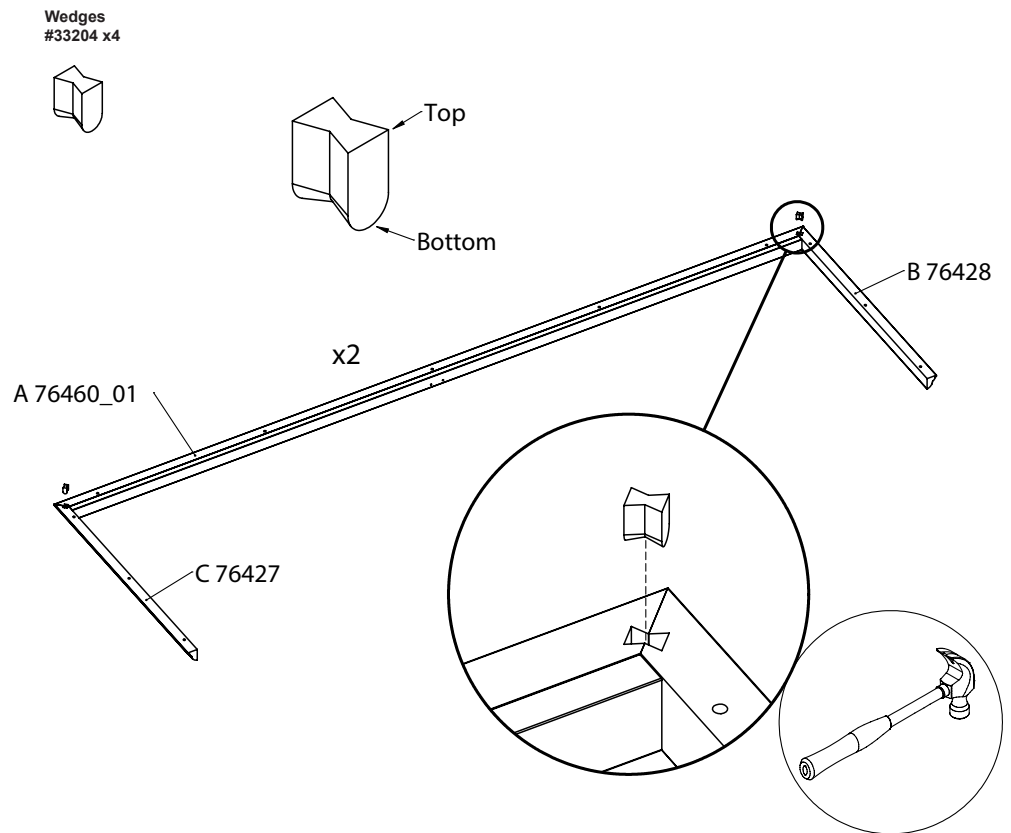

## Step 8

### Attach panels

Place bottom panel **ID** on top as shown, and insert flat head screws **26033**.

Fittings you will need for this step:

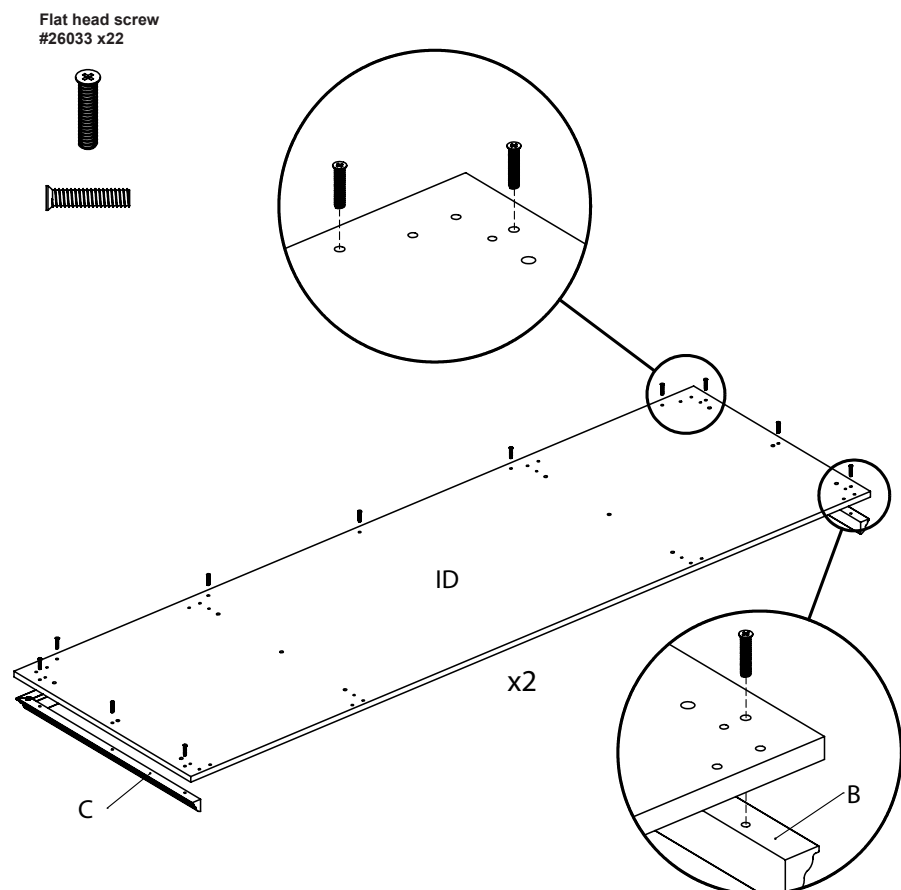

# Assembly Instructions

## Step 9

### Attach bracket

Insert bracket **11229** into fixed shelf **UC** and **UB**.

Fittings you will need for this step:

Bracket  
#11229 x20

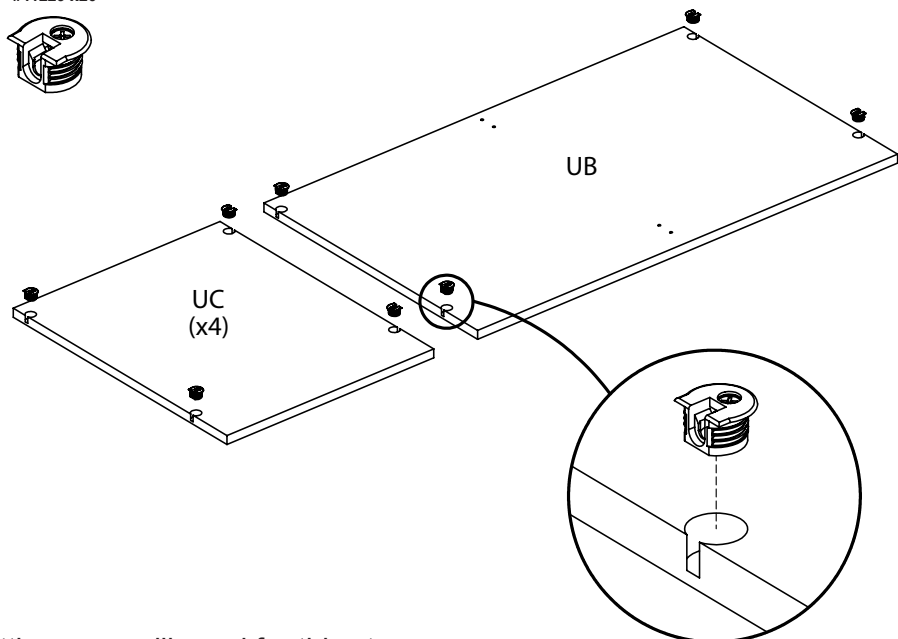

## Step 10

### Attach side panels

Insert connector bolt **25610** with allen key **97642** into bottom panel **ID** to the bottom ends of the side panels.

Please use books or the like to support the side panels when assembling this step.

Fittings you will need for this step:

Connector bolt  
#25610 x12

Allen key  
#97642 x1

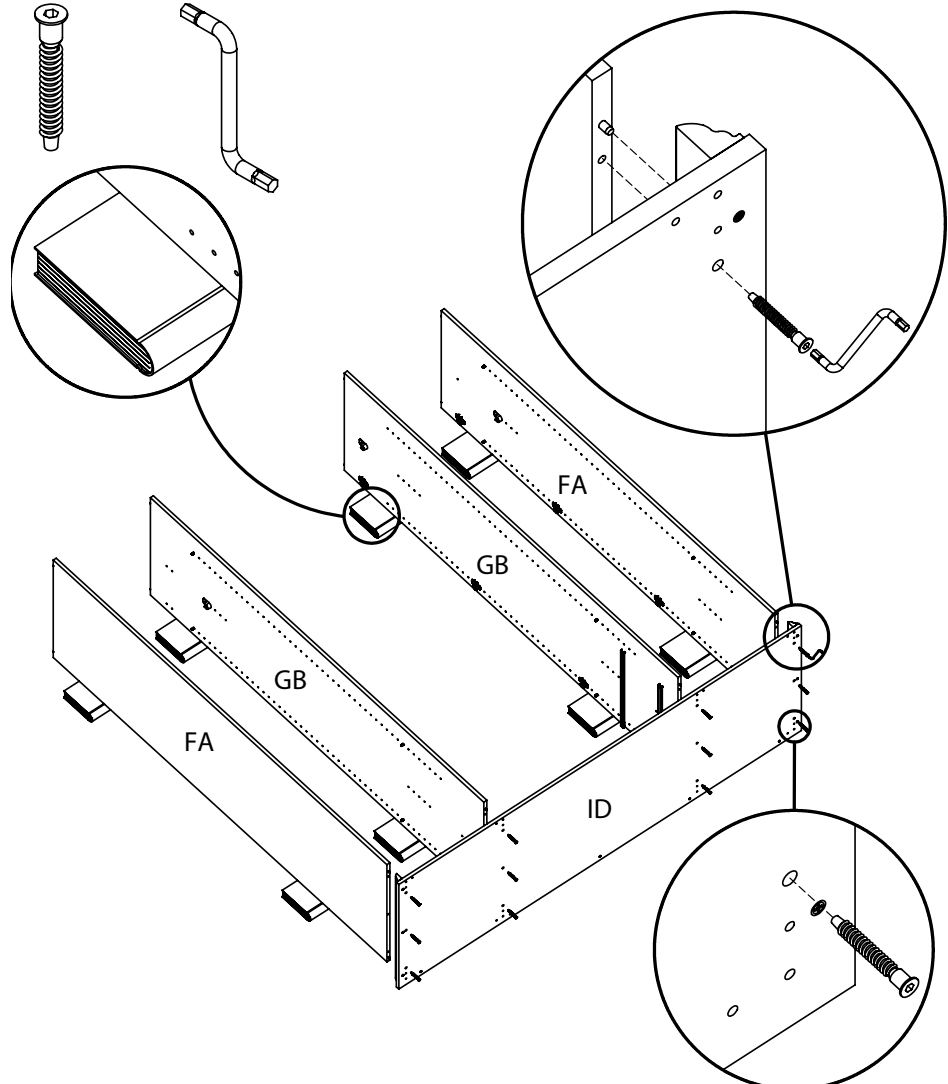
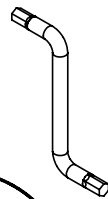
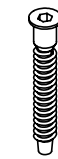

# Assembly Instructions

## Step 11

Insert connector bolt **25610** with allen key **97642** into top panel **ID** to the top ends of the side panels.

Fittings you will need for this step:

Connector bolt #25610 x12      Allen key #97642 x1

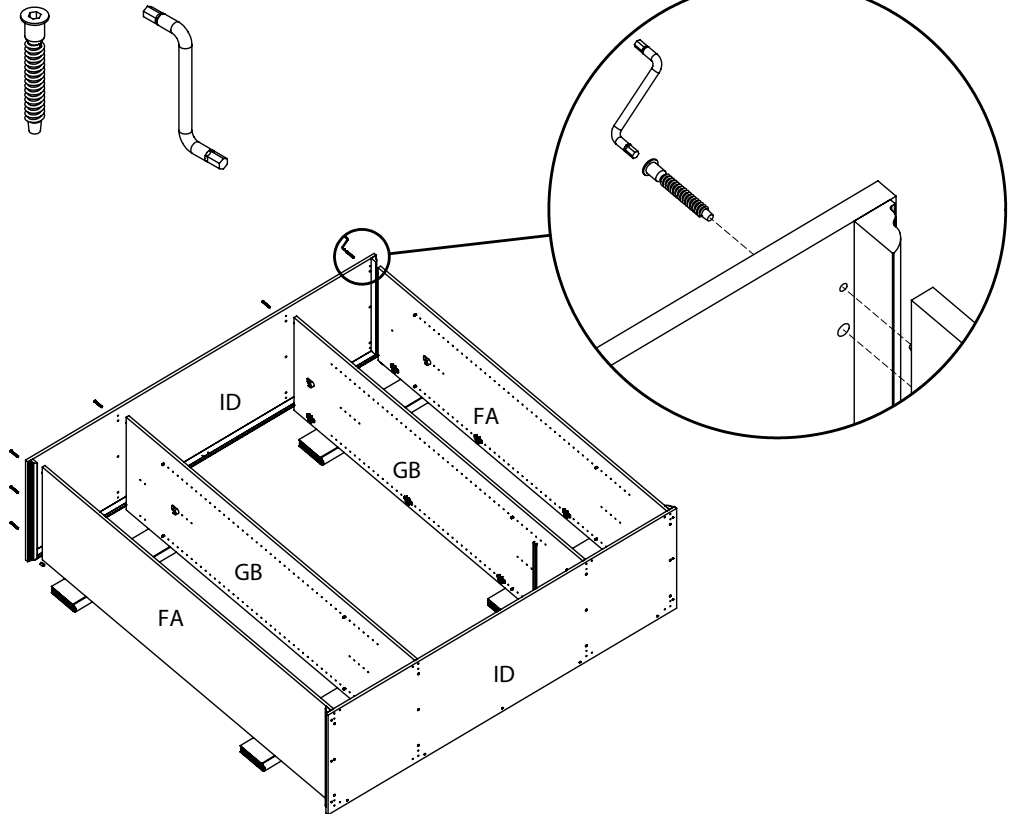

## Step 12

### Attach shelves

Place fixed shelf **UC** as pictured. Slide down over the screws and then tighten.

Afterwards, attach wrench **97642** with screws **25610** onto the centered backside of the front profile **A**.

Please note the orientation of the assembly as pictured.

Fittings you will need for this step:

Screw #25440 x2      Wrench #91410 x1

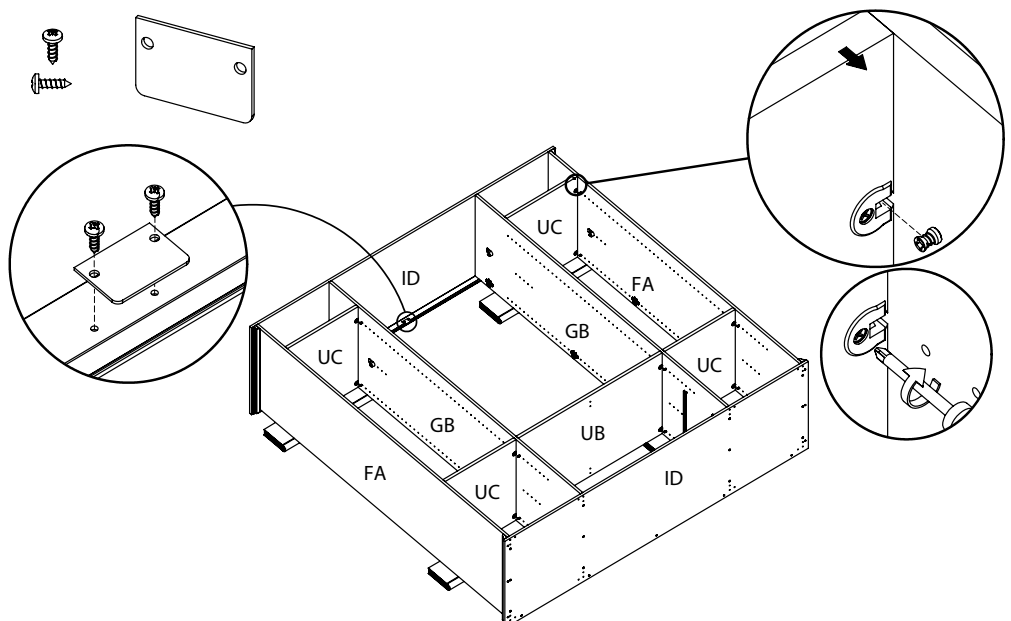

# Assembly Instructions

## Step 13

### Fixate back panels

Use nails **23006** to fix the back panels.

Fittings you will need for this step:

Big nail  
#23010 x6

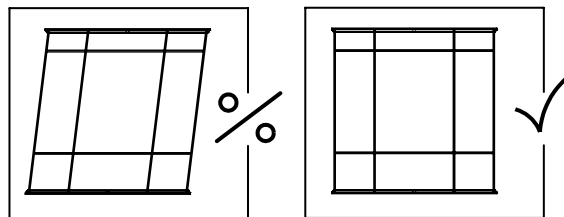

**Important:**  
The unit **MUST** be square when the back panels are attached.

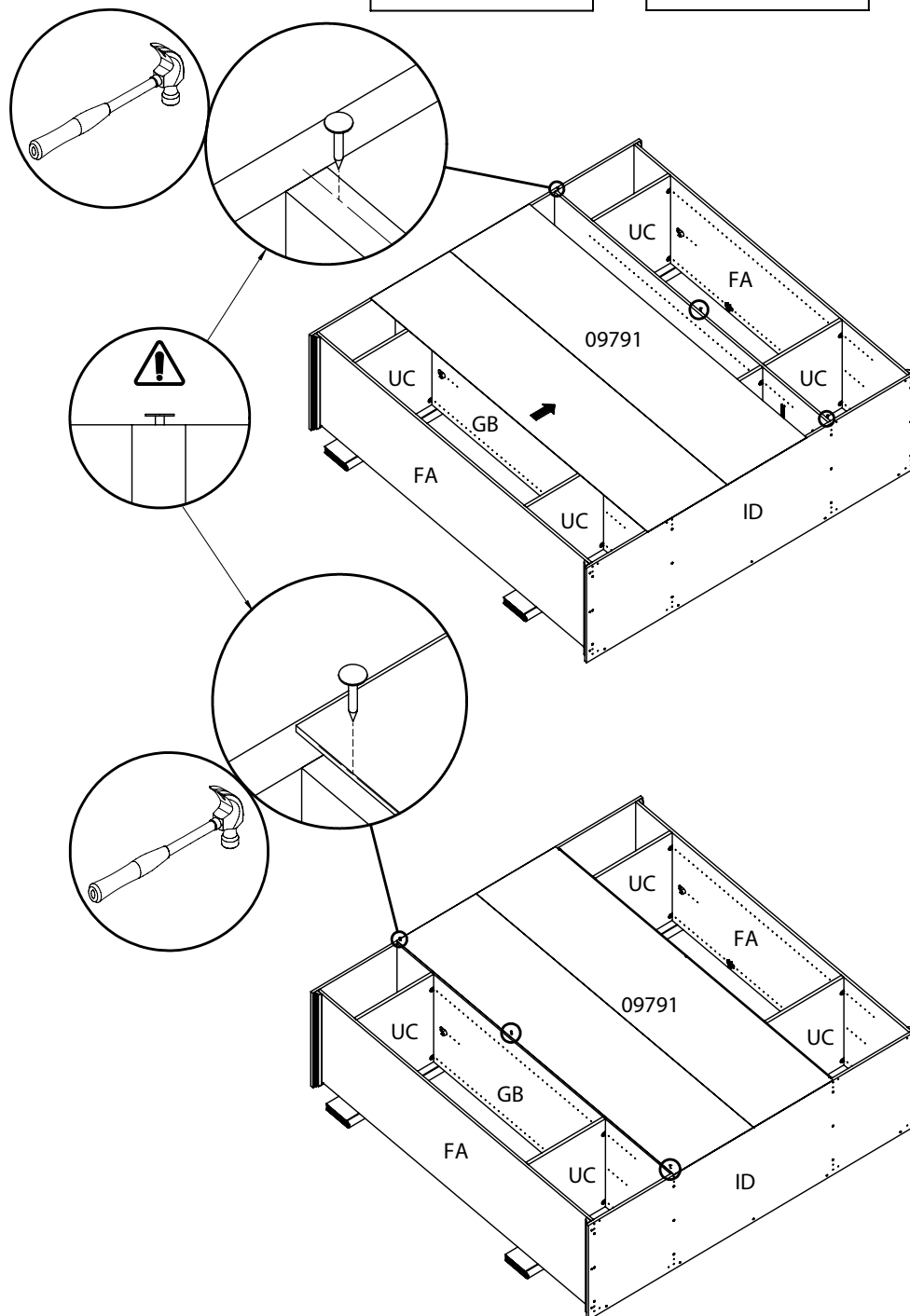

Fixate the back panels with the big nails **23010** and nail **23006**.

# Assembly Instructions

## Step 14

### Fixate the remaining back panels

Slide the back panels as shown, so that they meet back panel **09791**.

Fix the 2 back panels **09790** with nails **23006**.

Fittings you will need for this step:

Nail #23006 x4  
Big nail #23010 x30

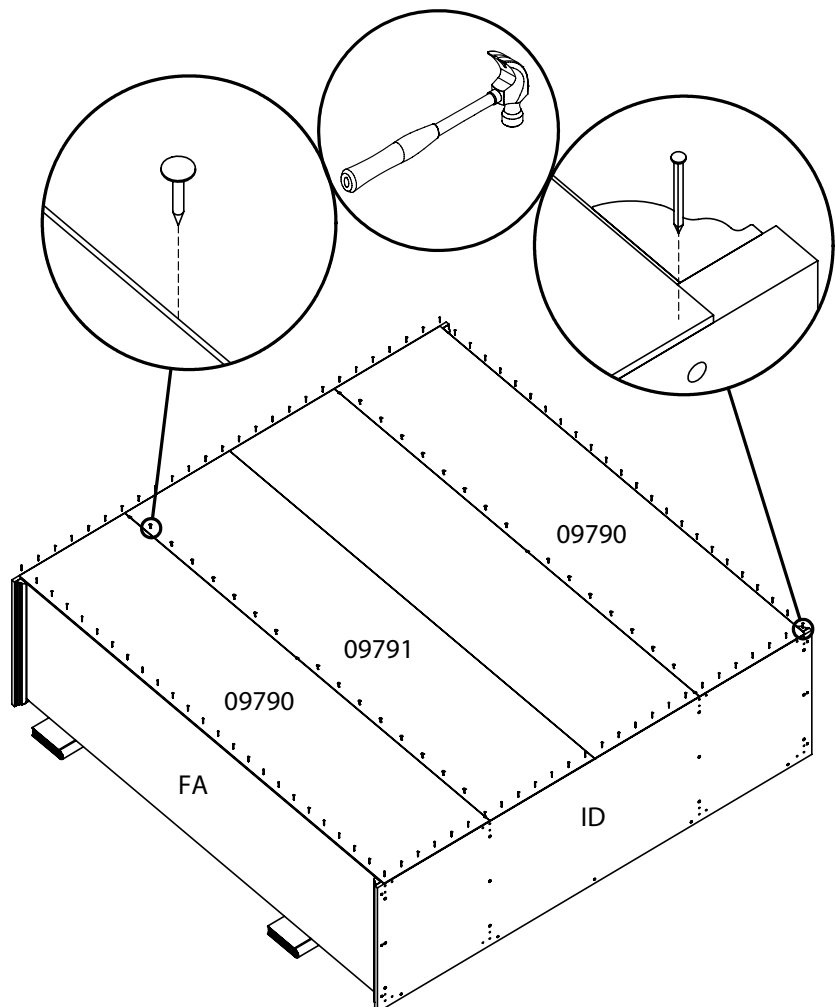
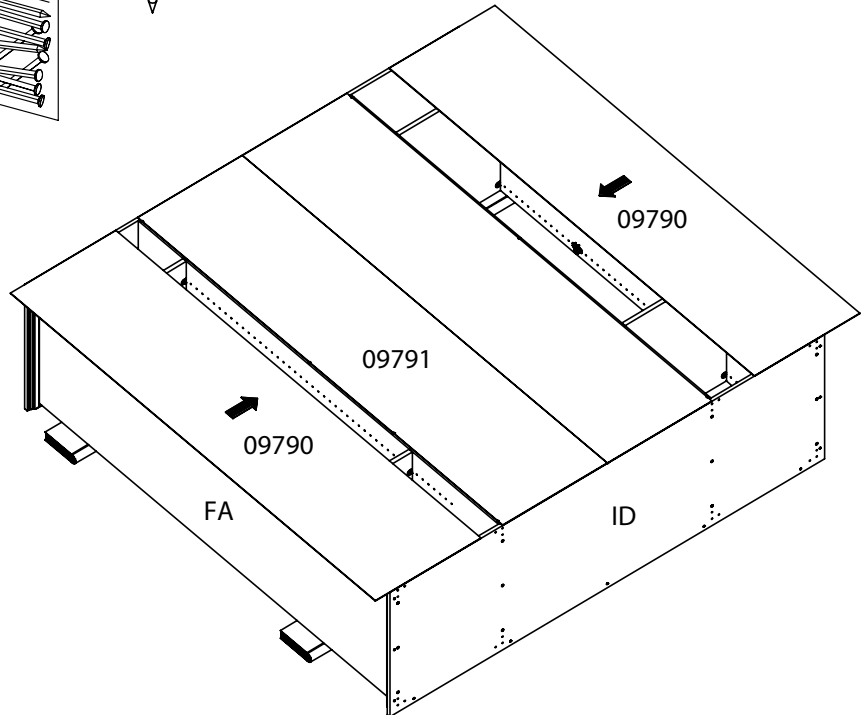
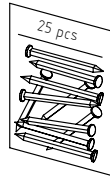

# Assembly Instructions

## Step 15

### Attach floor gliders

Place the floor gliders **63008** in the holes of the bottom panel **ID**.

Use a wooden block between your hammer and the floor gliders.

Fittings you will need for this step:

Floor glider  
#63008 x8

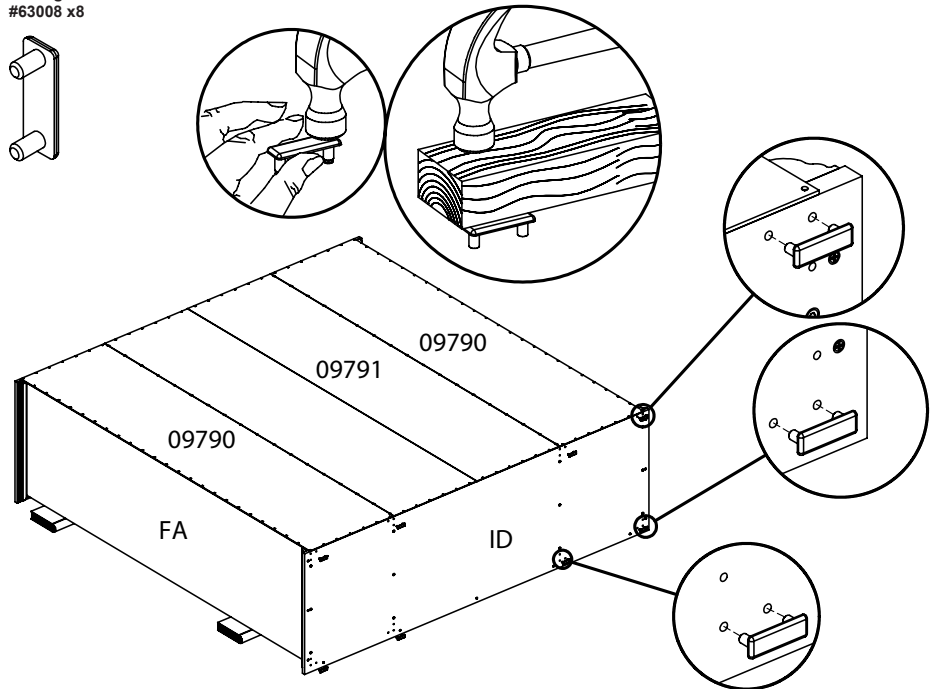

## Step 16

### Mount on your wall

Fix the unit to your wall with strap **94009**.

 The screw supplied with the anti-topple bracket is to be used only to fix the anti-topple bracket to the furniture. In addition to this, you will need to choose a screw or a fitting suitable for securing the bracket to the kind of wall you have.

If you are unsure about what type of screw to use, please contact your local hardware store for more information.

Fittings you will need for this step:

Strap  
#94009 x2

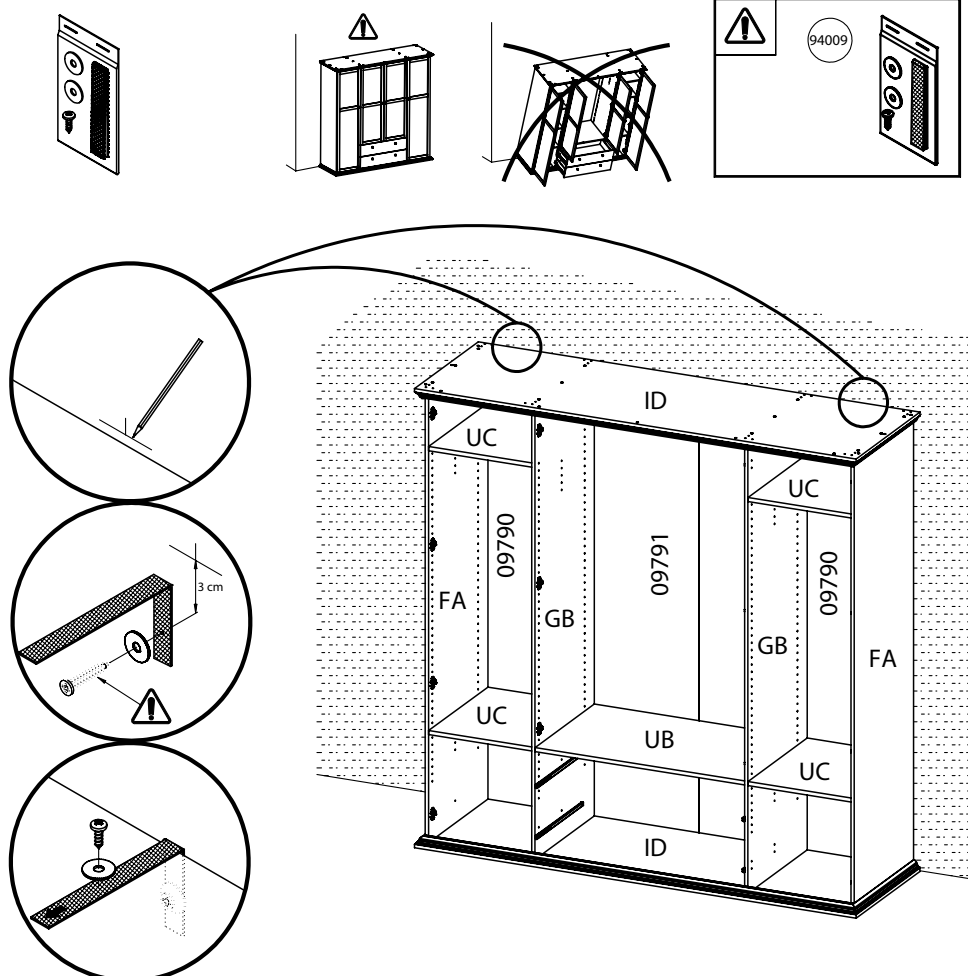

# Assembly Instructions

## Step 17

Insert hangers **72501** and **72509**.

Fittings you will need for this step:

Hanger  
#72509 x1

Hanger  
#72501 x2

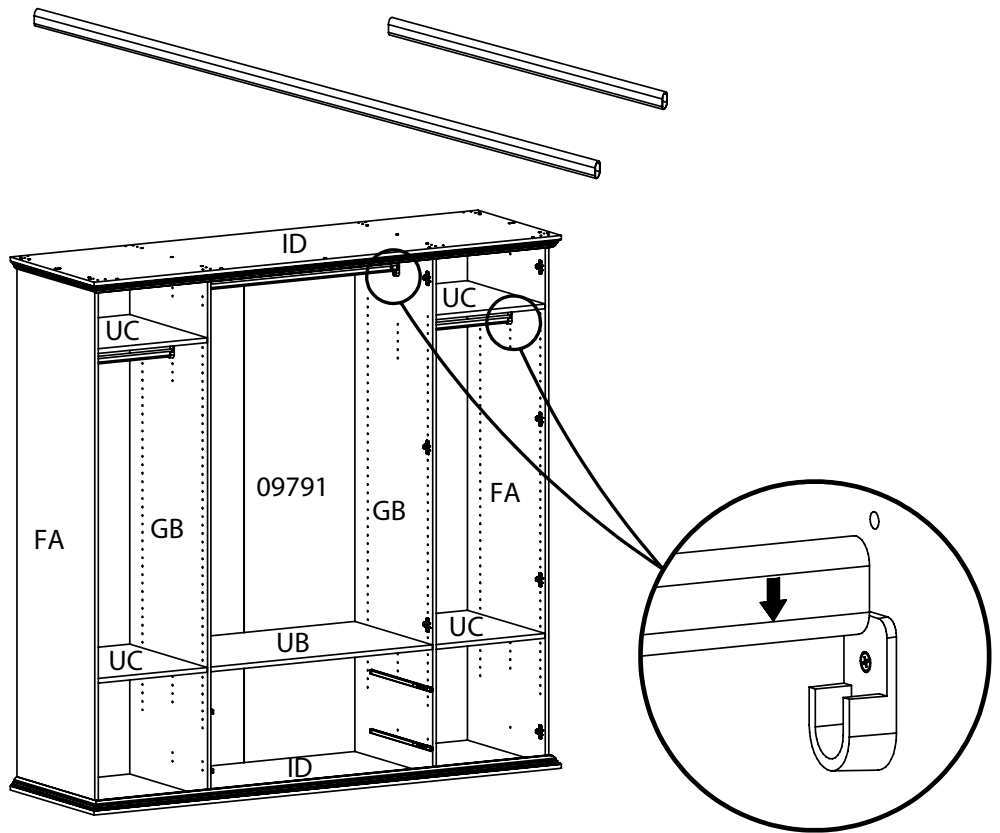

## Step 18

### Attach the shelf supports

Press the shelf support **11042** into the holes of side panels **FA**.

Press down the loose shelf panel **T** x4.

Fittings you will need for this step:

Shelf support  
#11042 x16

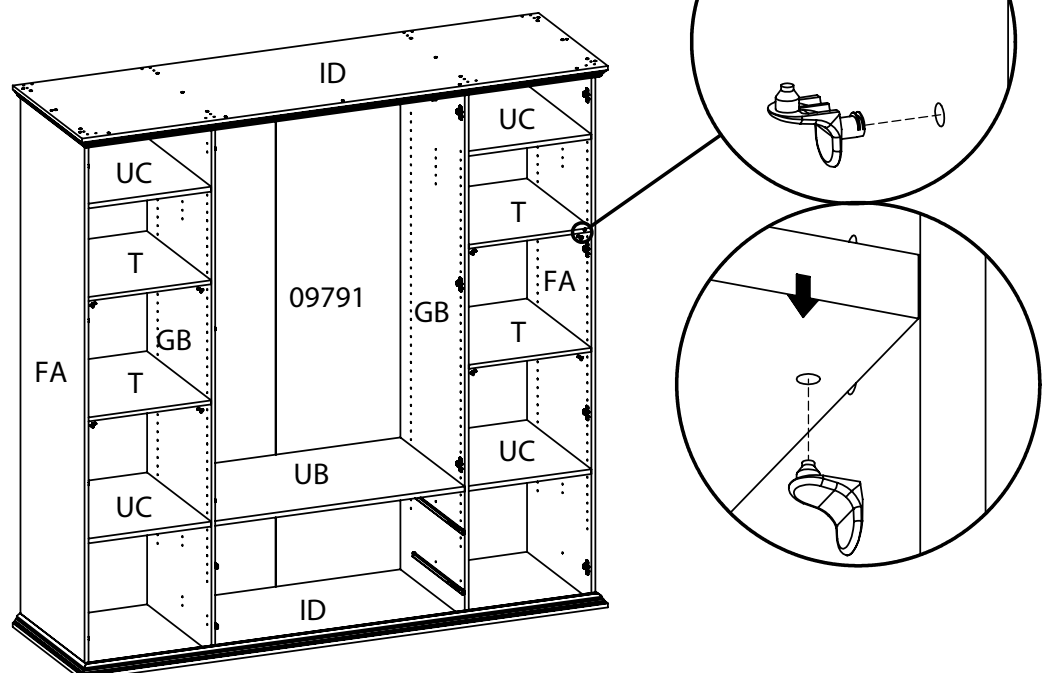



# Assembly Instructions

## Step 19

Insert stop **96203** on the front edges of both divider panels **GB**.

Please ensure that the stops are placed on the edges as illustrated, sitting as close to the side panels **FA**.

Fittings you will need for this step:

Stop  
#96203 x4

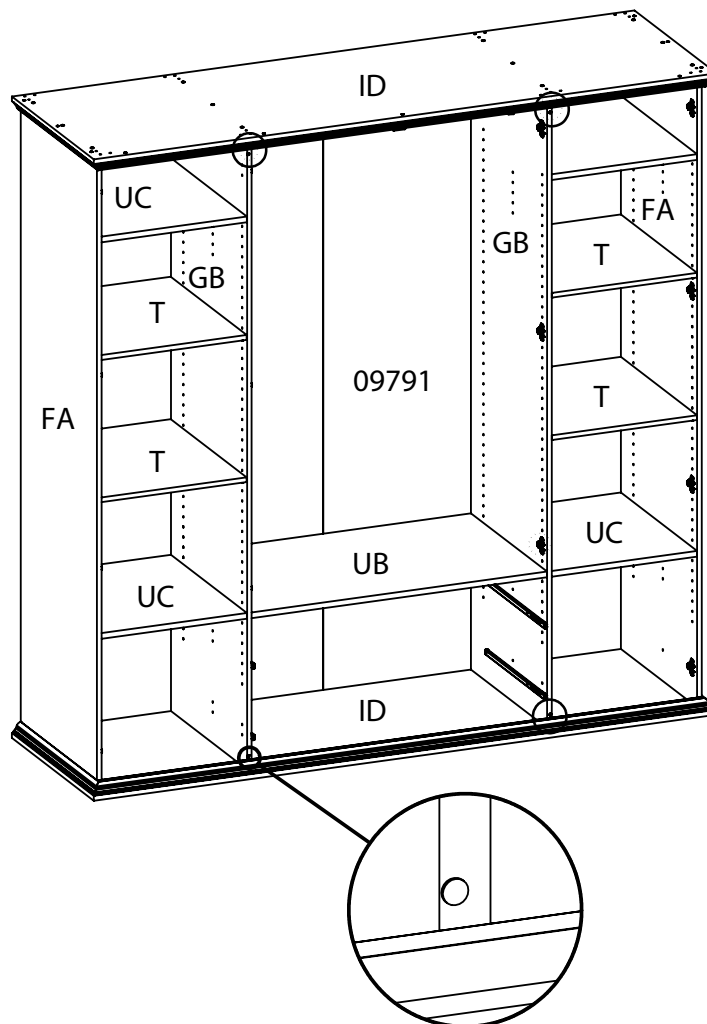

## Step 20

### Attach hinges

Press hinge **52291** into the large holes on the doors **18732**, **18743** and **18744**. Screw the pre-attached screws into the holes on the doors.

Fittings you will need for this step:

Hinge  
#52291 x14

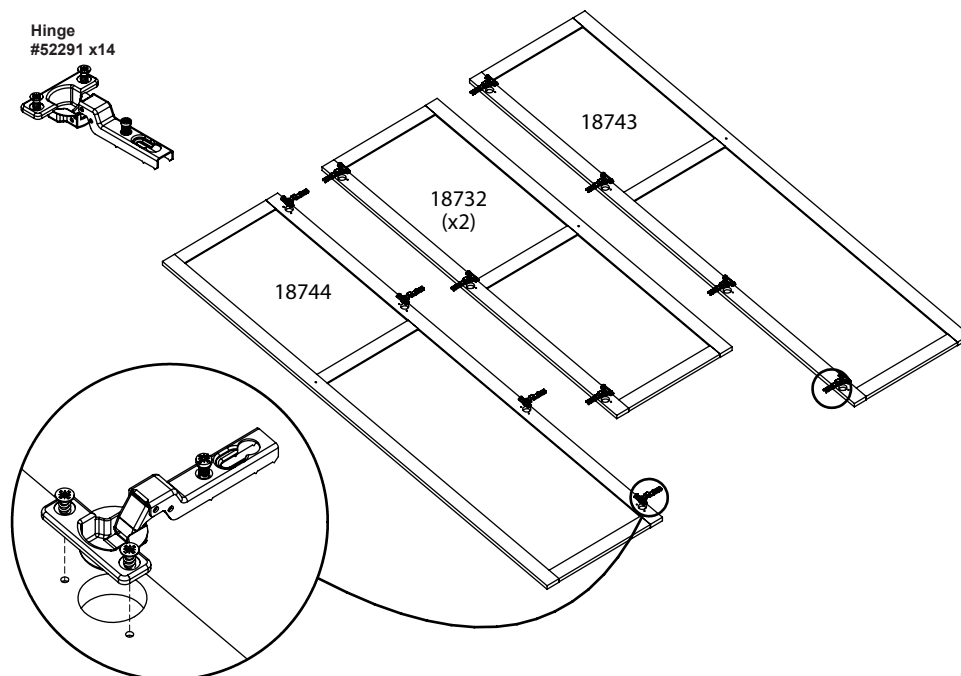
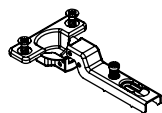

# Assembly Instructions

## Step 21

### Attach doors

Slide the pivoting part of the two hinges over the hinge plates. Tighten the screw on the hinge plate until the doors are supported by the hinges.

Please refer to the last page of this assembly instruction, showing how to adjust the doors according to your needs.

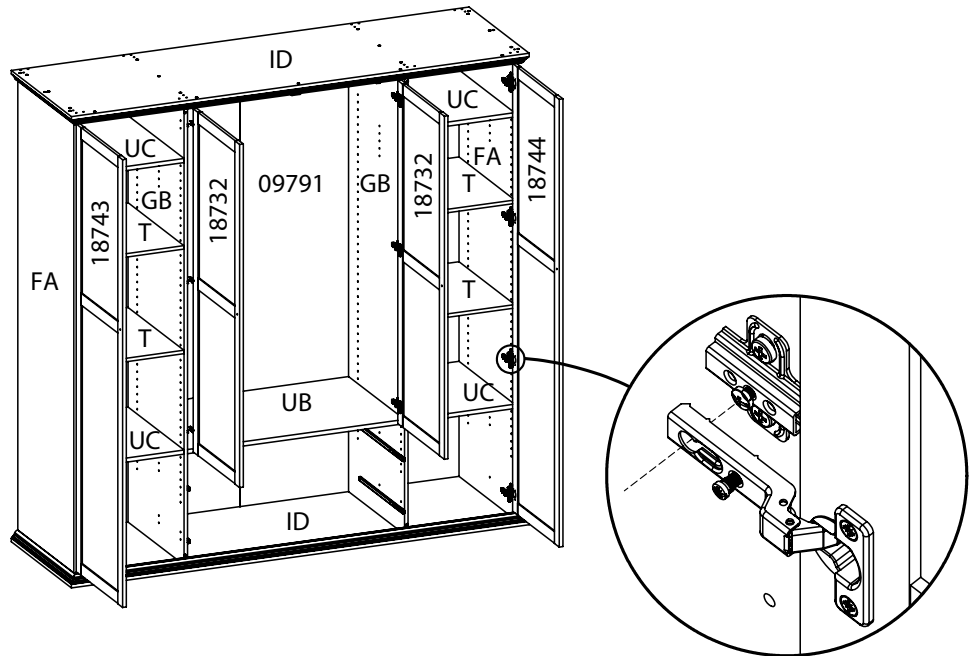

## Step 22

### Attach door handles and stops

Pass machine screw **26232** through the doors, into the handles **81040** and then tighten.

Insert stop **96203** on shelf **UB**, and the wrench as illustrated.

Fittings you will need for this step:

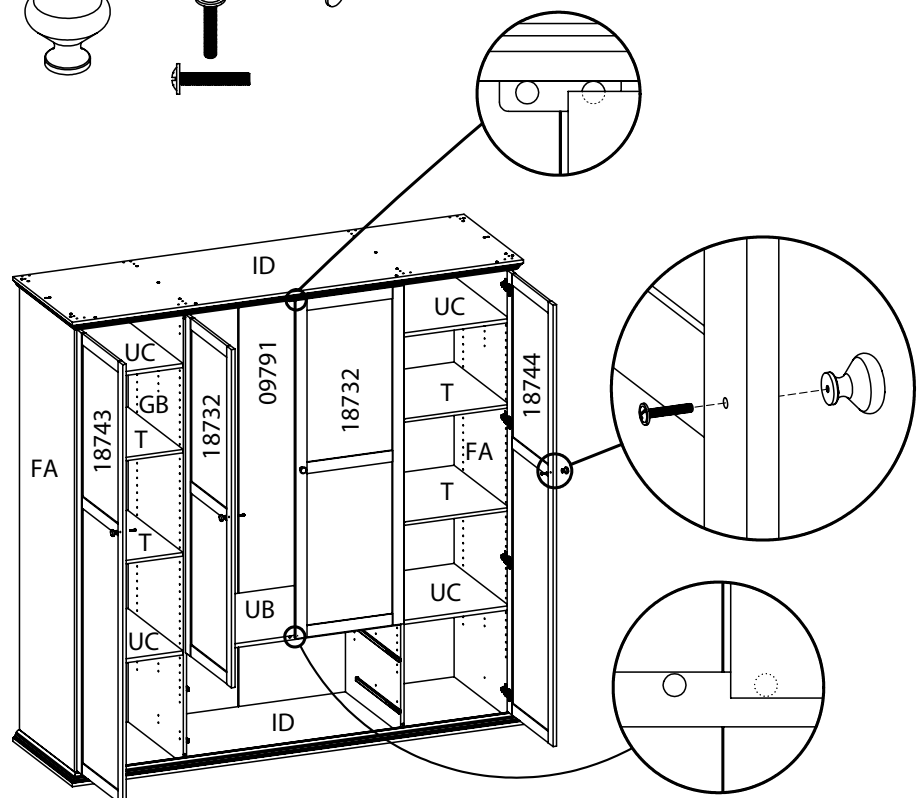

# Assembly Instructions

## Step 23

### Assemble drawers

Put in dowels **20203** into the end holes of **00733** and **00734** as illustrated.

Fittings you will need for this step:

Dowel  
#20203 x8

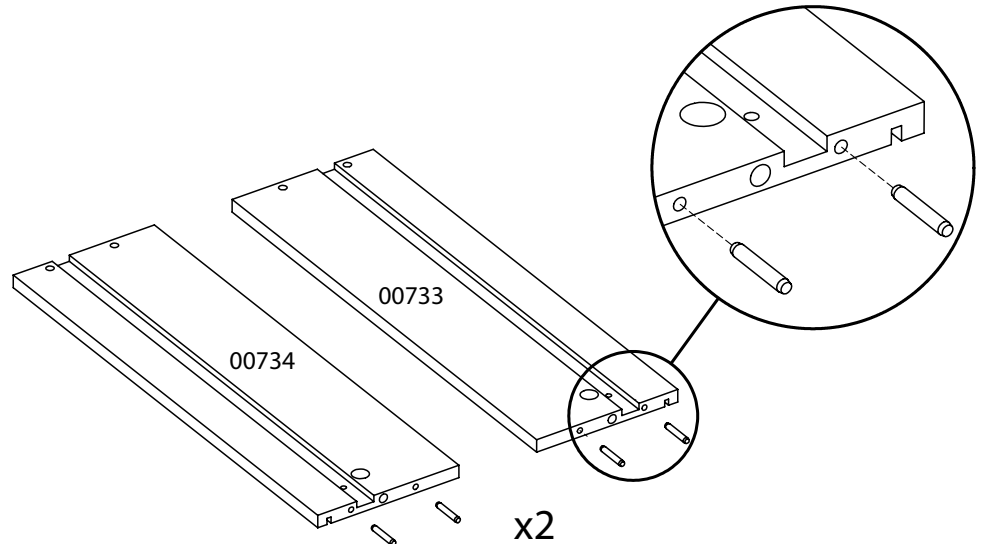

## Step 24

### Assemble drawers

Insert cam **31687** into **00733** and **00733**, followed by inserting cam bolt **31515** into drawer front **EE**.

Fittings you will need for this step:

Cam  
#31687 x4



Cam bolt  
#31315 x4

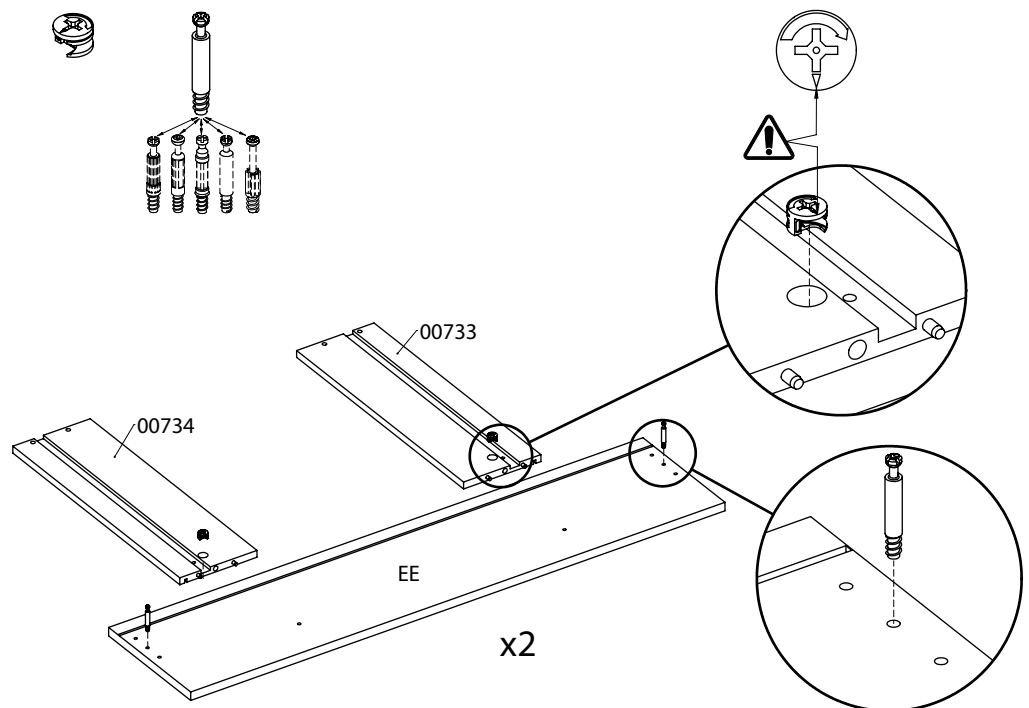
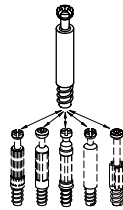

# Assembly Instructions

## Step 25

### Fix drawer panels together

Align the left **00734** and right **00733** drawer sides with the drawer back **03336**, as illustrated. Use drawer fasteners **20228** with a hammer to fix the drawer sides and the drawer back together.

Fittings you will need for this step:

Drawer fastener  
#20228 x8

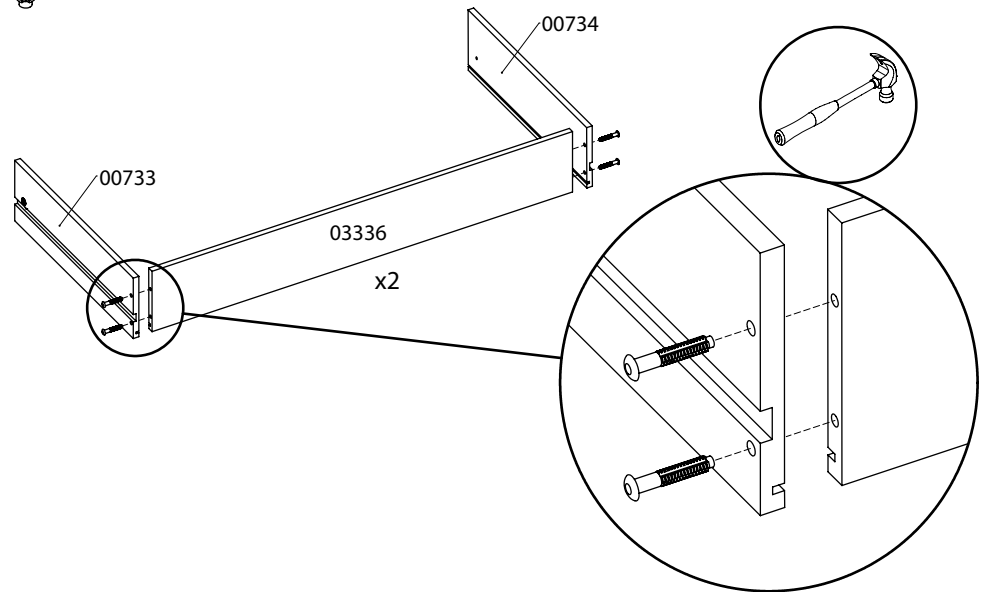
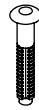

## Step 26

### Attach the drawer bottom

Slide the drawer bottoms **07165** into the grooves made of the drawer sides.

Please note to slide in the drawer bottom with the finished side upwards.

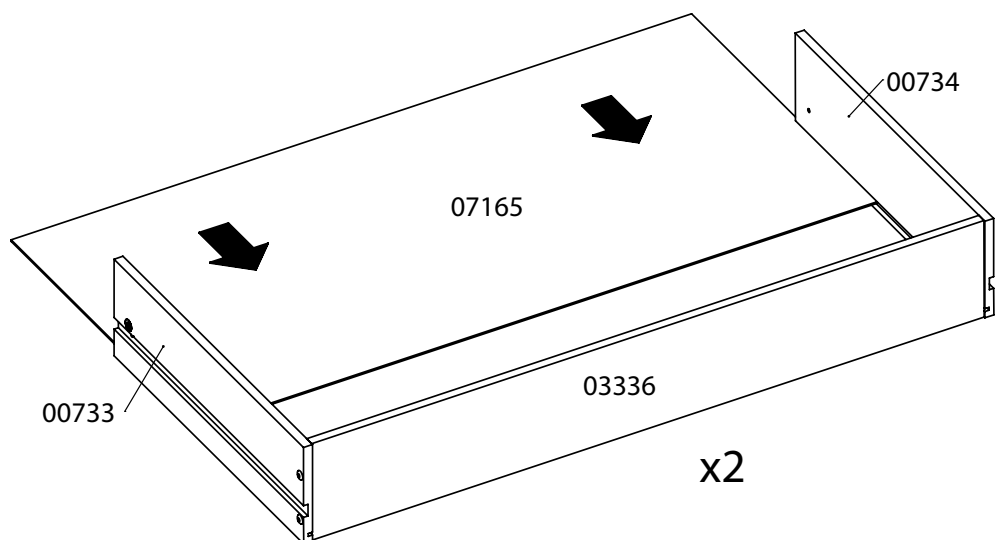

# Assembly Instructions

## Step 27

### Attach the drawer front

Attach the drawer front **EE** by placing dowels and cam bolt into the designated holes.

Please note the illustration for correct assembly.

Afterwards, tighten the cams.

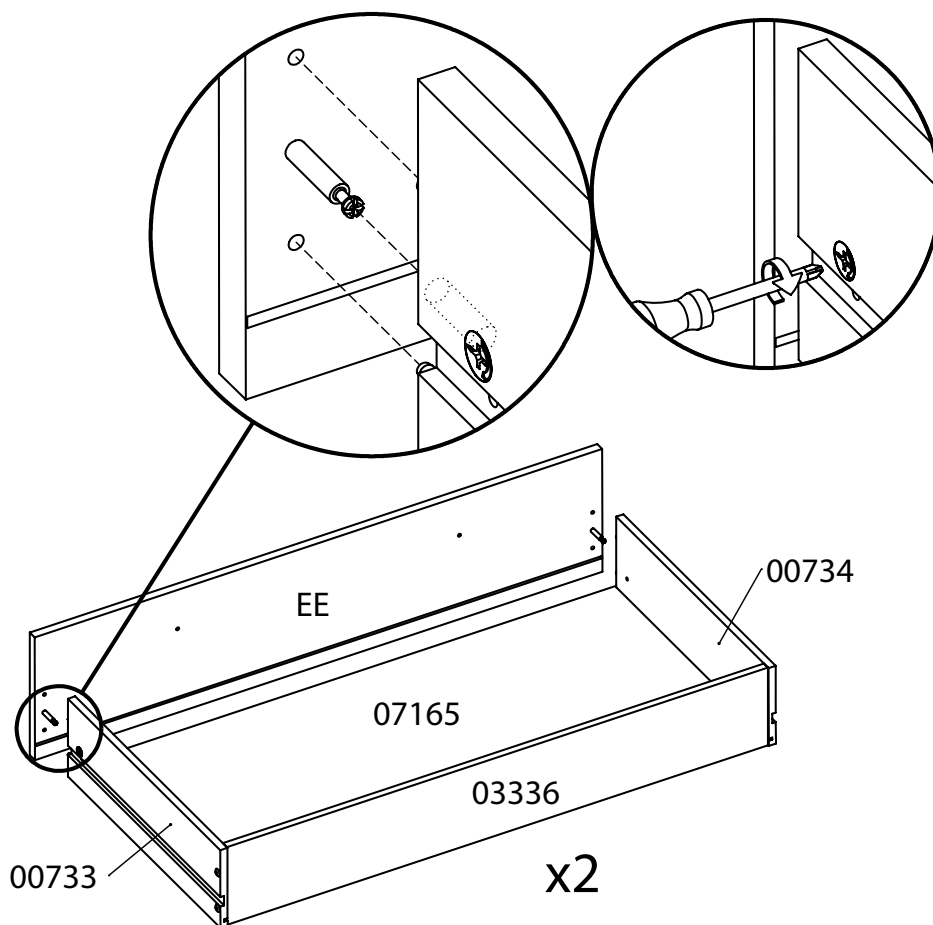

## Step 28

### Attach the handles

Attach the handles **81040** in front of the drawer front **EE**. Use the machine screws **26232** to tighten the handles.

Fittings you will need for this step:

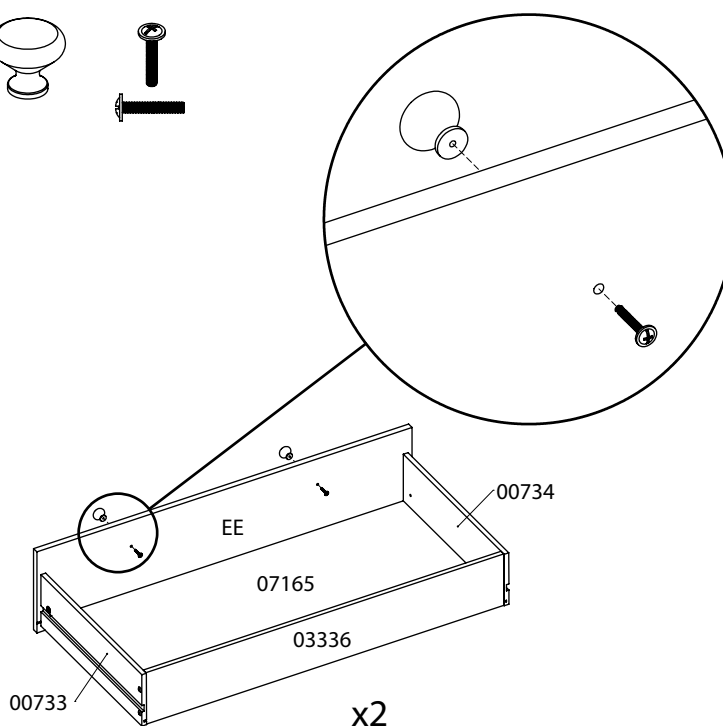
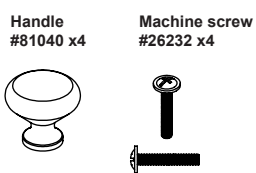

# Assembly Instructions

## Step 29

### Attach the drawer bottom supports

Place the drawer bottom supports **10503** on the underside of the drawers. See the detail drawing for correct assembly.

Use the screw **25440** to tighten.

Fittings you will need for this step:

Screw  
#25440 x6



Drawer bottom support  
#10503 x2

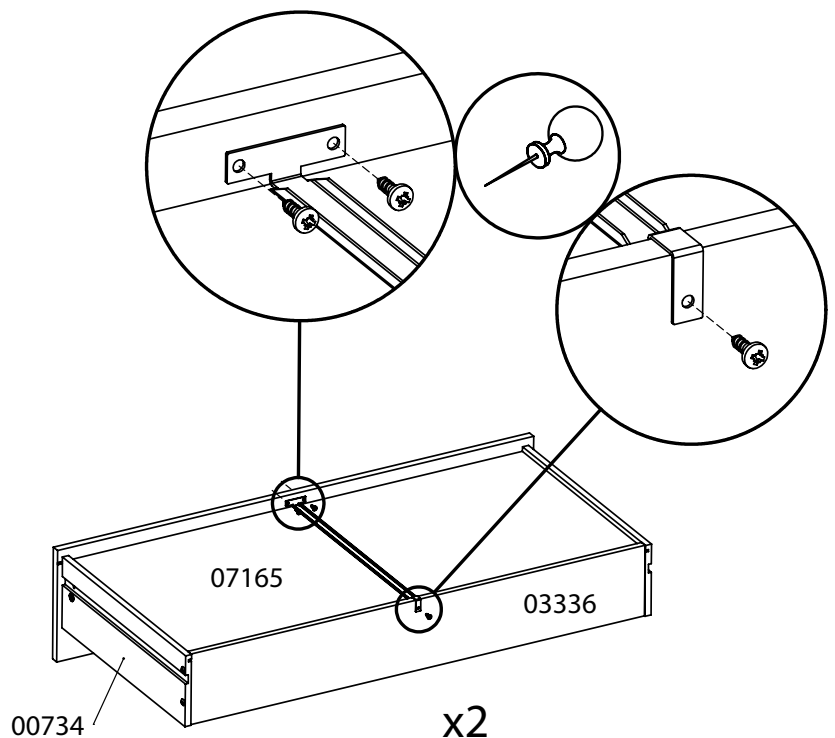
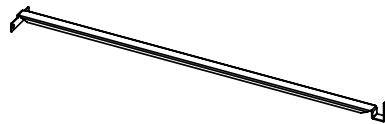

## Step 30

### Pull out the runners

Pull out all of the drawer runners, before mounting the drawers.

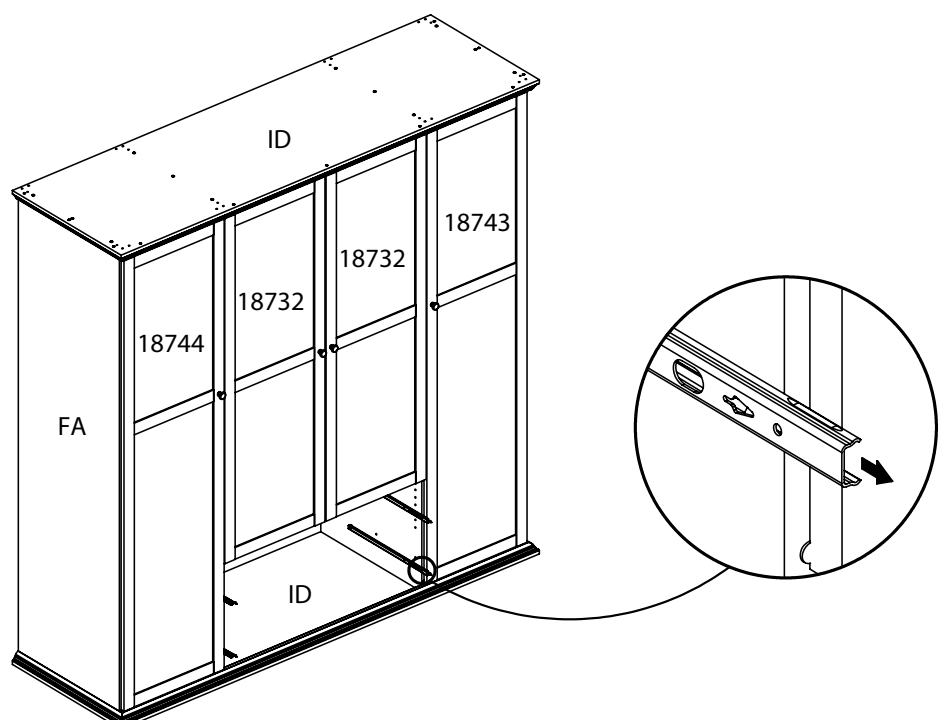

# Assembly Instructions

## Step 31

### Mount the drawers

Slide the drawers onto the drawer runners, using the drawers outside grooves.

Once the drawer runners reach the drawer front, screw in the machine screws **26214** from the inside of the drawers to fasten the drawer runners to the drawers.

See the illustration for reference.

Fittings you will need for this step:

Machine screw  
#26214 x4

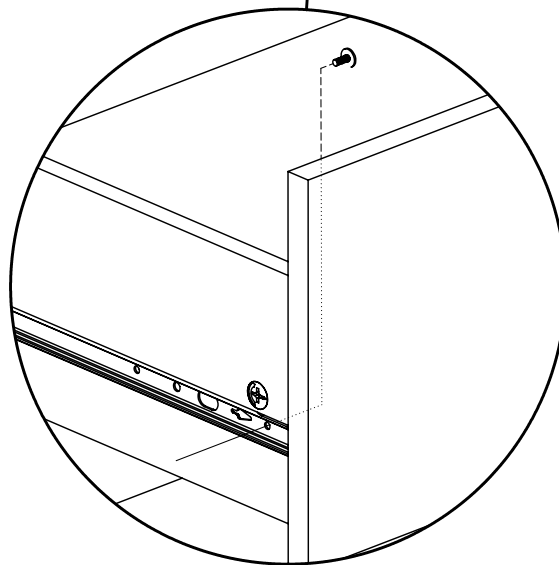
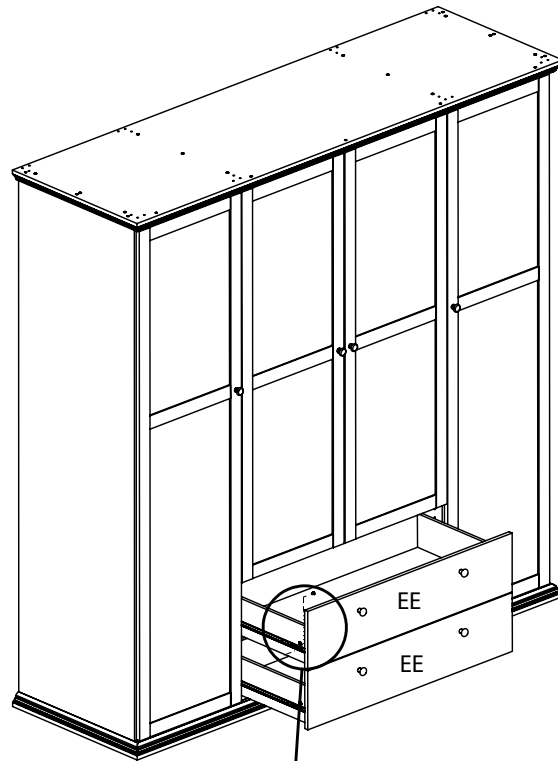

**After this assembly step, the assembly is now complete.**

If you need help or have damaged or missing parts, call the **Customer Helpline:**  
**Argos = 0345 6400800**

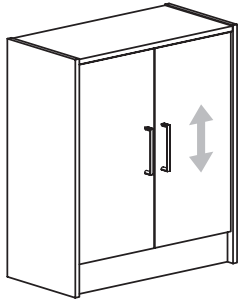

1.

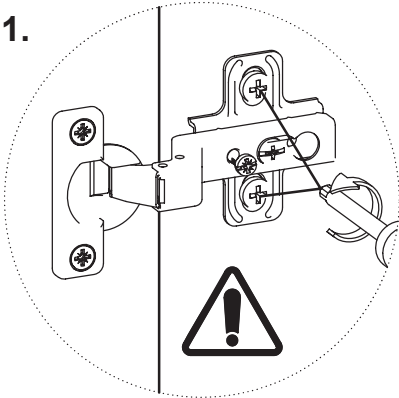

2.

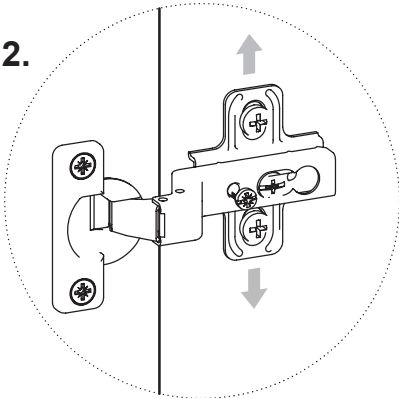

3.

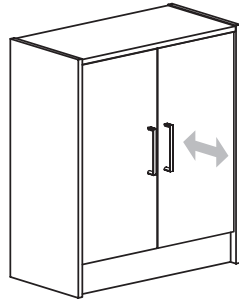
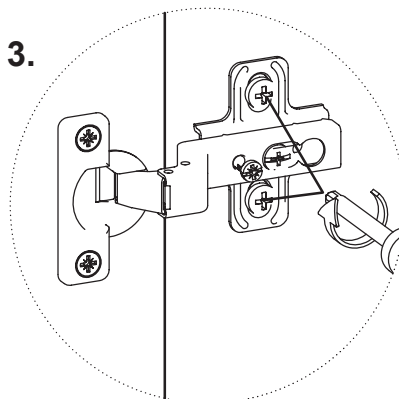

1.

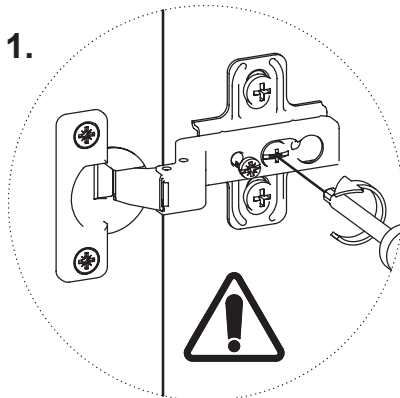

2.

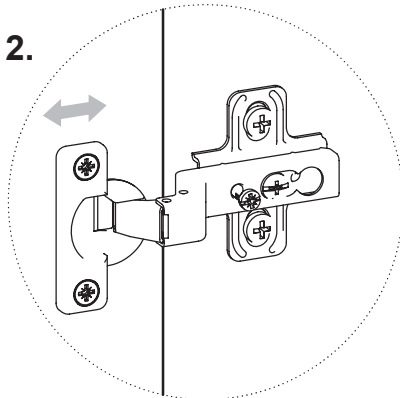

3.

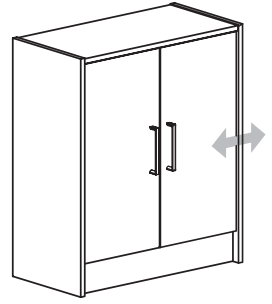
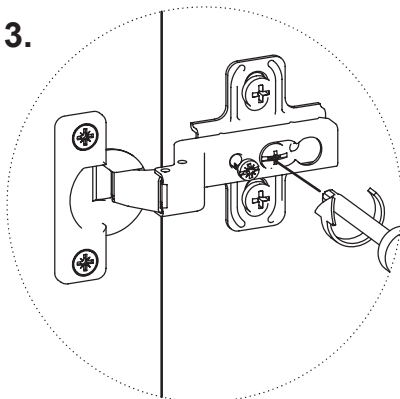

1.

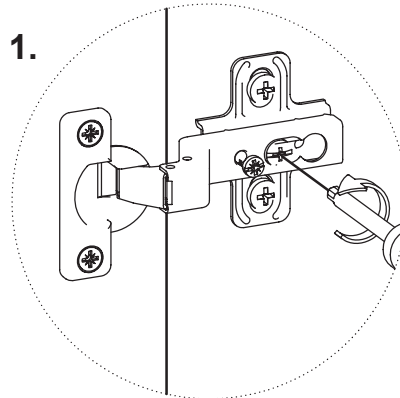

2.

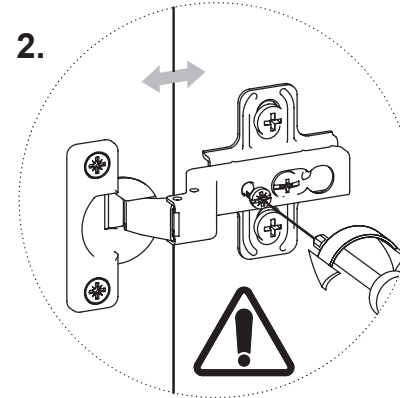

3.

