

Amersham - Solid Pine Small Sideboard

Assembly Instructions - Please keep for future reference

724/4199

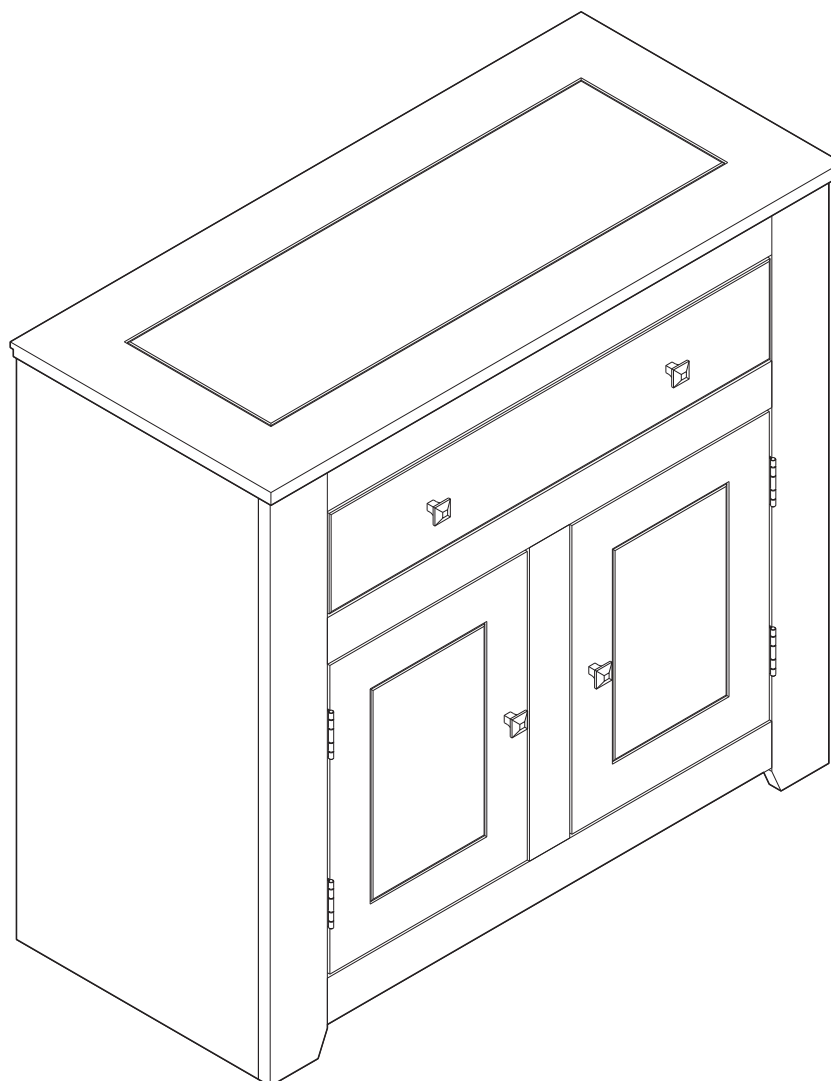

Dimensions

Width - 92cm

Depth - 42cm

Height - 84cm

Important – Please read these instructions fully before starting assembly

If you need help or have damaged or missing parts, call the **Customer Helpline: 03456 400 800**



Safety and Care Advice

Important – Please read these instructions fully before starting assembly

- Check you have all the components and tools listed on pages 2 and 3.
- Remove all fittings from the plastic bags and separate them into their groups.
- Keep children and animals away from the work area, small parts could choke if swallowed.
- Make sure you have enough space to layout the parts before starting.
- Do not stand or put weight on the product, this could cause damage.
- Assemble the item as close to its final position (in the same room) as possible.
- Assemble on a soft level surface to avoid damaging the unit or your floor.

• This product has been produced from natural timber; you may notice some variation in the grain and colour of different component parts which is normal for furniture produced using natural wood and is not the result of any manufacturing fault.

• The product has been treated with a wax and oil finish to prevent dirt ingress and preserve moisture.

• On unpacking the furniture you may notice an odour due to this treatment; this will disappear once the furniture is unpacked and assembled after a period of time.

• This process may leave some staining on the packaging material; please take care to ensure this does not transfer to clothing or carpeted surfaces during assembly.

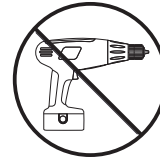

as this could damage the unit. Only use hand screwdrivers.

• We do not recommend the use of power drill/drivers **for inserting screws**,

• Parts of the assembly will be easier with 2 people.

• Dispose of all packaging carefully and responsibly.

Care and maintenance

- Use an appropriate furniture polish for natural wood furniture and a dry cloth to clean the product.
- Avoid placing the furniture in direct sunlight as this will cause the timber to prematurely age.

• From time to time check that there are no loose screws on this unit.

• This product should not be discarded with household waste. Take to your local authority waste disposal centre.

Note: If required the next page can be cut out and used as reference throughout the assembly. Keep this page with these instructions for future reference.

Components - Panels

Please check you have all the panels listed below

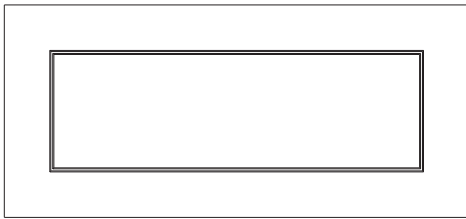

1 Top panel (92 x 42cm)

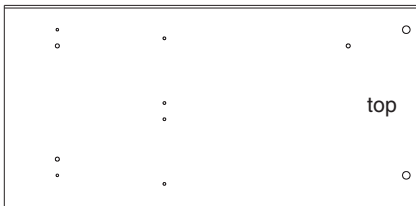

2 Right side panel (82 x 40cm)

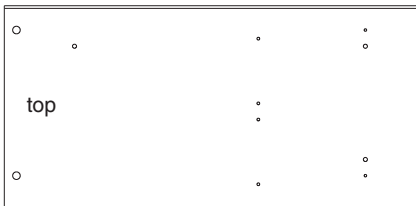

3 Left side panel (82 x 40cm)

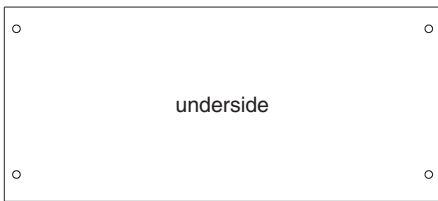

4 Base panel (86.4 x 38.4cm)

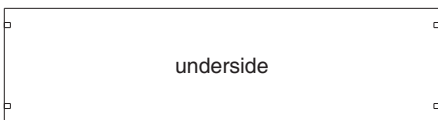

5 Shelf (86.2 x 22.6cm)



6 H profile (86 x 2cm)

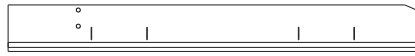

7 Right front frame (82 x 9.2cm)

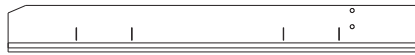

8 Left front frame (82 x 9.2cm)



9 Top front frame (75.6 x 6.5cm)

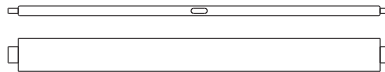

10 Bottom front frame x 2 (75.6 x 6.5cm)



11 Drawer front (71 x 14cm)



12 Drawer back (68.6 x 14cm)



13 Back panel x 2 (88.2 x 36.4cm)



14 Drawer bottom (69.6 x 30.4cm)

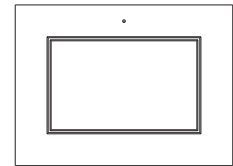

15 Door x 2 (43 x 31.8cm)



16 Vertical frame (47.7 x 6.5cm)

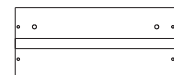

17 Drawer sides x 2 (31.8 x 14cm)



18 Drawer runner x 2 (35.2 x 8cm)













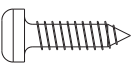

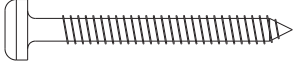

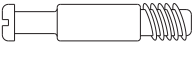
19 Block x 4 (10 x 2cm)

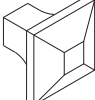
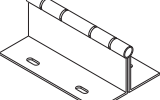
Components - Fittings

If you have damaged or missing components, call the **Customer Helpline: 03456 400 800**

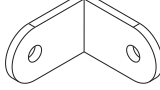
Please check you have all the fittings listed below

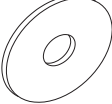
Note: The quantities below are the correct amount to complete the assembly. In some cases more fittings may be supplied than are required.

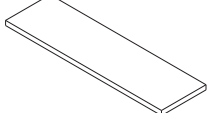
<p>A </p> <p>Wooden dowel x 18</p>	<p>B </p> <p>14mm Screw x 27</p>	<p>C </p> <p>30mm Screw x 8</p>
<p>D </p> <p>35mm Screw x 18</p>	<p>E </p> <p>22mm Bolt x 4</p>	<p>F </p> <p>Metal dowel x 8</p>
<p>G </p> <p>Locking nut x 8</p>	<p>H </p> <p>Door / Drw handle x 4</p>	<p>I </p> <p>Door hinge x 4</p>
<p>J </p> <p>Clip x 2</p>	<p>K </p> <p>Plug x 2</p>	<p>L </p> <p>Shelf support x 4</p>
<p>M </p> <p>Metal bracket x 1</p>	<p>N </p> <p>Nail x 32</p>	<p>O </p> <p>Washer x 2</p>
<p>P </p> <p>Wall strap x 1</p>	<p>Q </p> <p>Door spacer x 1</p>	

Tools required

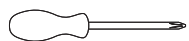

Phillips screwdriver
(medium & large)

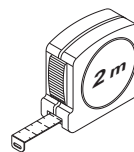

Ruler/tape
measure



Small
hammer



Eye protection
(when using a
hammer or glue)

Ruler - Use this ruler to help correctly identify the screws



Assembly Instructions

Step 1

Fixing right front frame to the right side panel
(Two people required for an easier assembly).

a: Insert right side panel **2** into right front frame **7** through joints.



Note:

Before fixing blocks **19** into place it is important to ensure that the slot and groove of parts **2** and **7** are fully pushed together and lined up correctly at the top and bottom.

b: Place blocks **19** between the two marks as shown. First fix to the side panel using screws **D**.

c: Fix front frame through blocks **19** using screws **D**.

a:

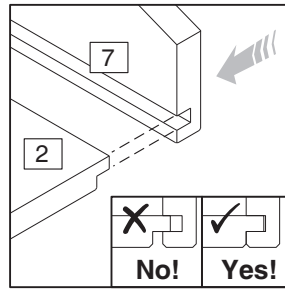

b:

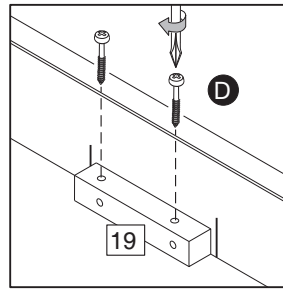

c:

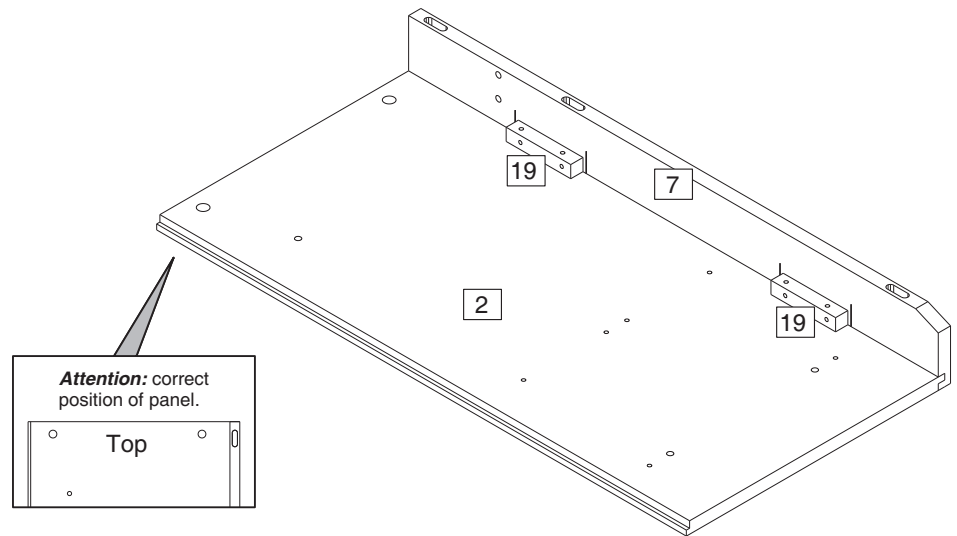
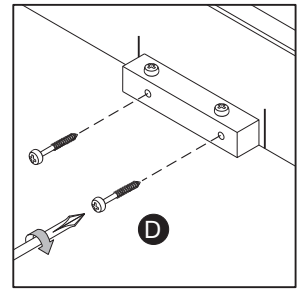

Step 2

Fixing left front frame to the left side panel
(Two people required for an easier assembly).

a: Insert left side panel **3** into left front frame **8** through joints.



Note:

Before fixing blocks **19** into place it is important to ensure that the slot and groove of parts **3** and **8** are fully pushed together and lined up correctly at the top and bottom.

b: Place blocks **19** between the two marks as shown. First fix to the side panel using screws **D**.

c: Fix front frame through blocks **19** using screws **D**.

a:

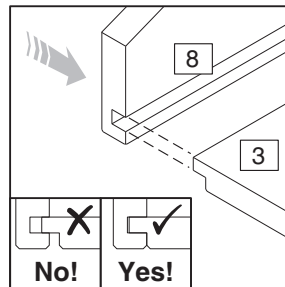

b:

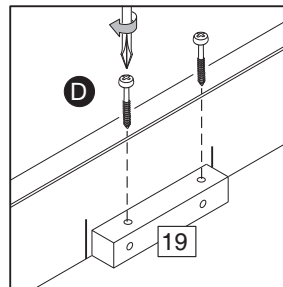

c:

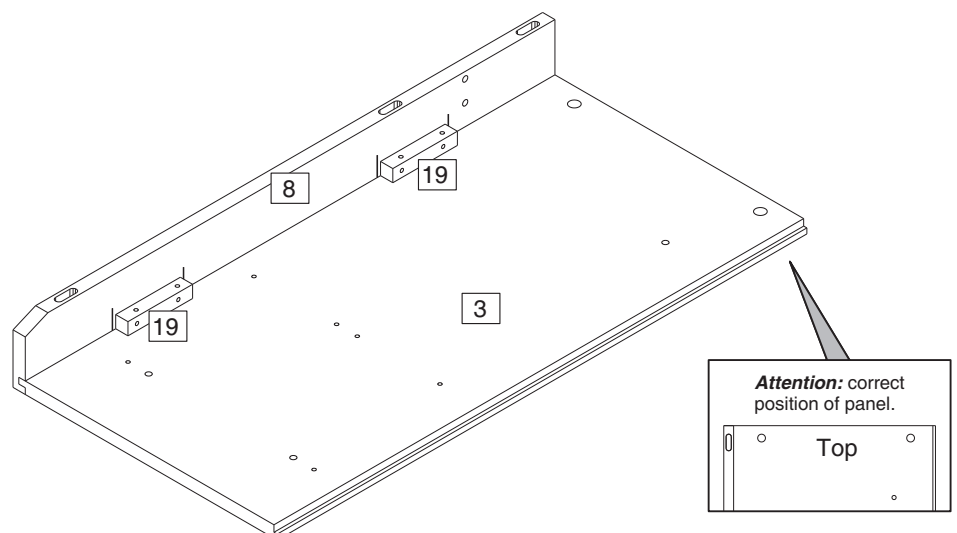
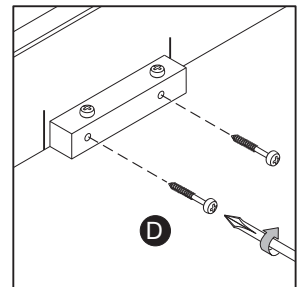

Assembly Instructions

Step 3

Fitting Metal dowels.

Screw metal dowels **F** into right side panel **2**, left side panel **3** and top panel **1**.



Note: Insert metal dowels as far as shown.

Do not over tighten.

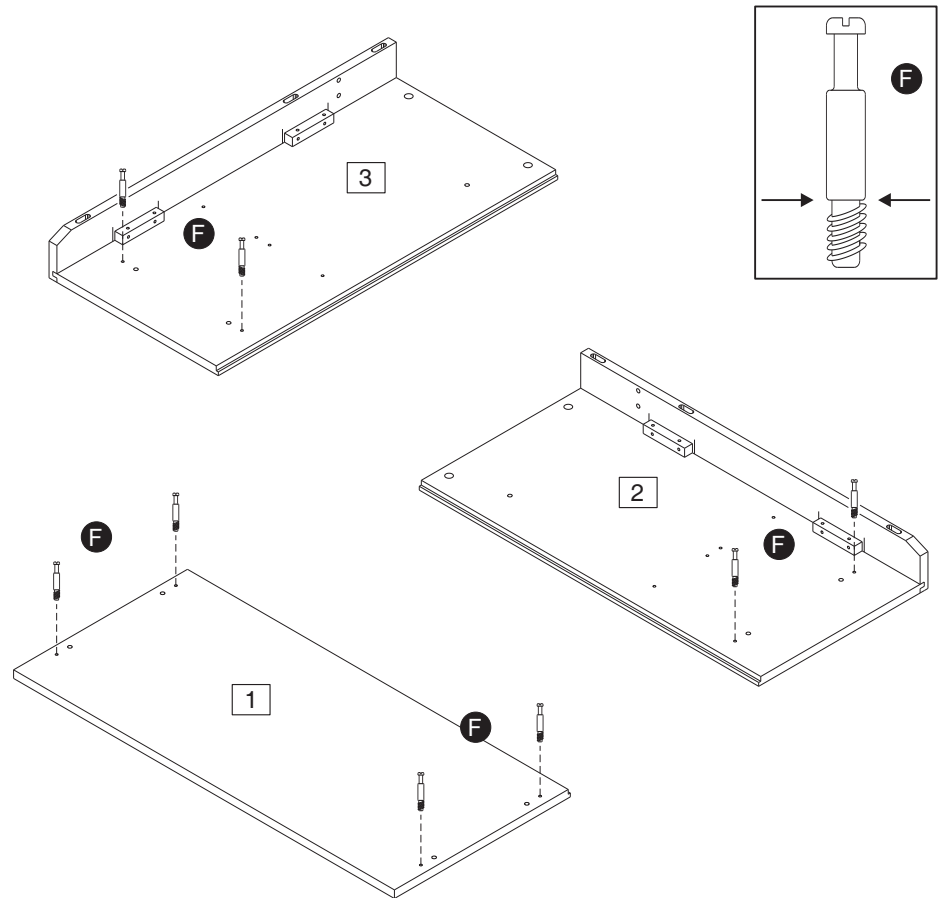

Step 4

Insert dowels **A** into the indicated parts.

Insert shelf supports **L** into the right side panel **2** and left side panel **3**.

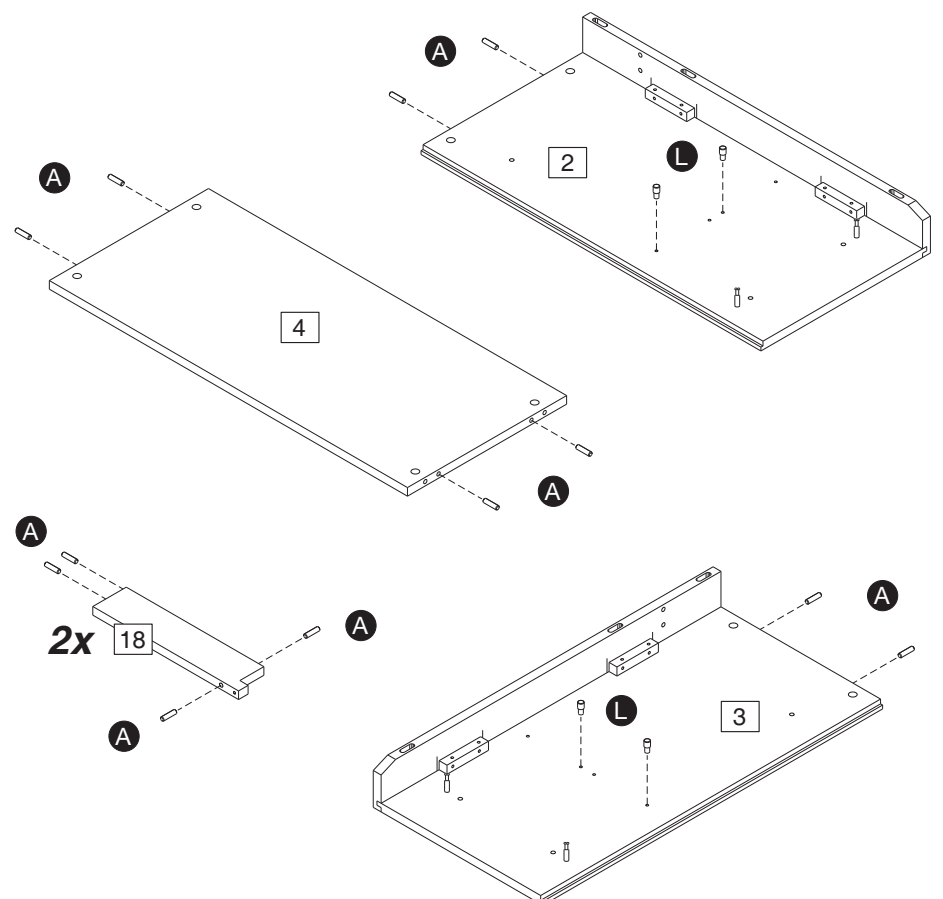

Assembly Instructions

Step 5

Fixing drawer runners.

a: Fit drawer runner **18** to the right side panel **2**. Fit and push dowels into the front frame first.

b: Attach drawer runner using screw **D**.

Repeat step 5 for the left side panel **3** and drawer runner.

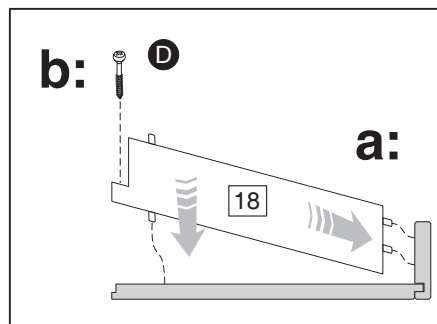
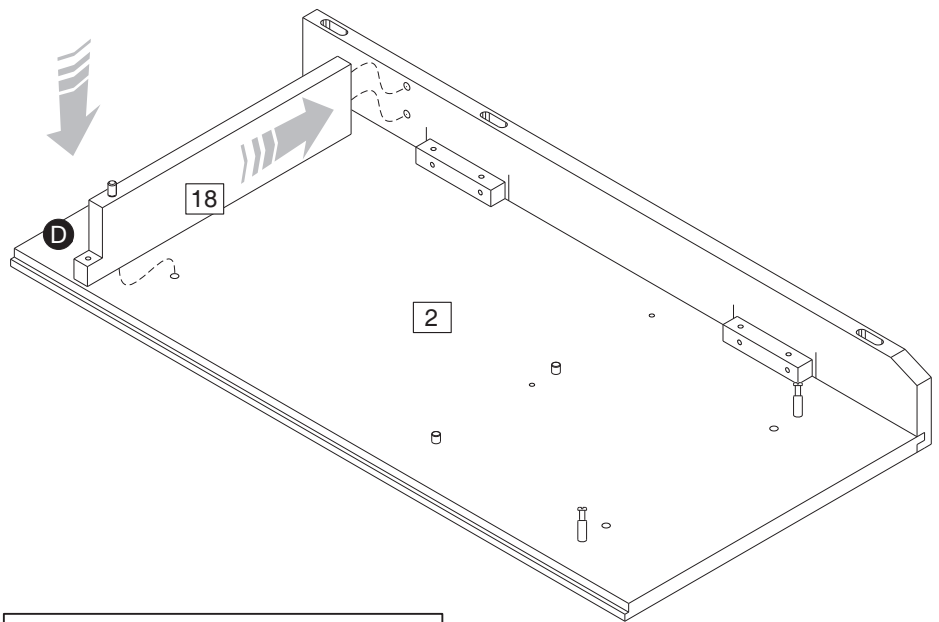

Step 6

Assembling parts.

Put parts **10** and **16** together as shown in the diagram.

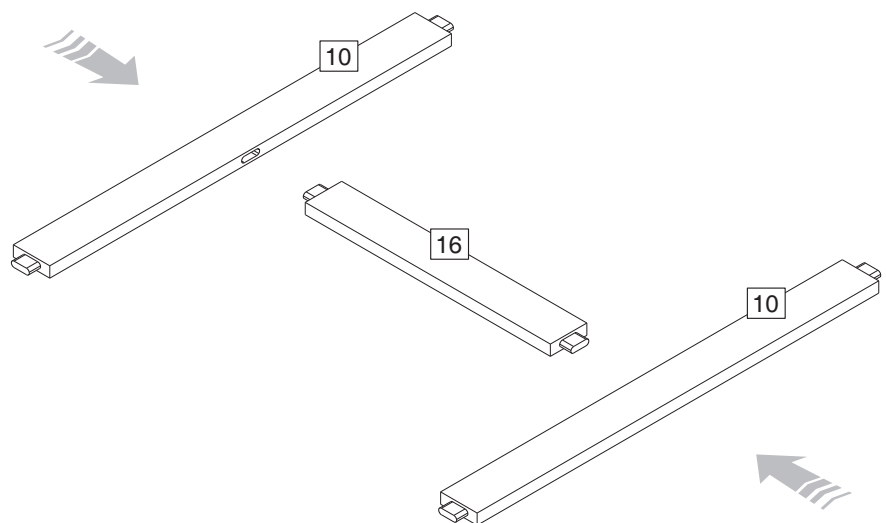

Assembly Instructions

Step 7

Insert the assembled frame and top front frame **9** into the holes on left side panel **3**.

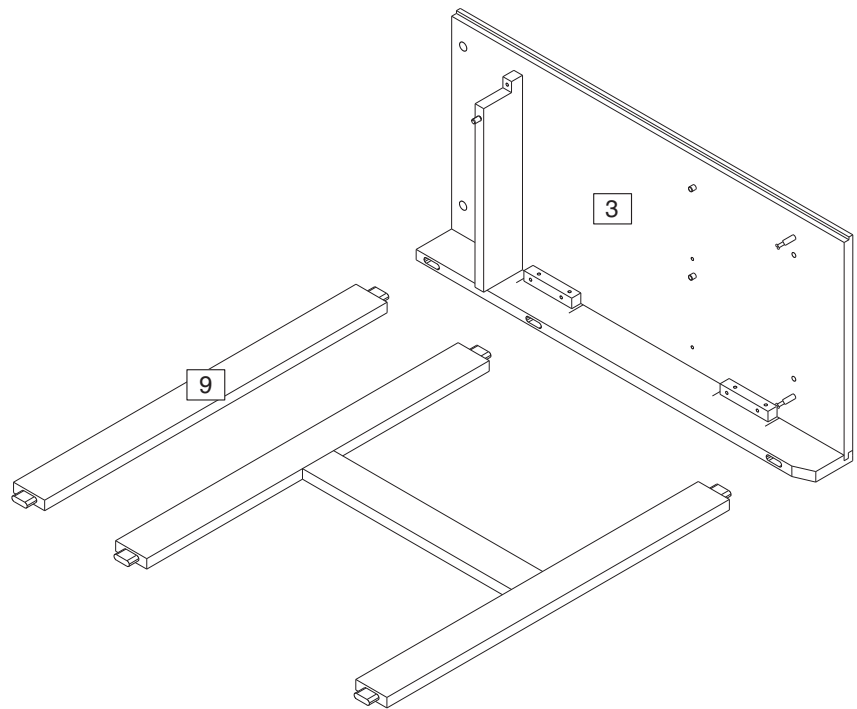

Step 8

Fixing base panel.

With help, fit base panel **4** to the left side panel.

Insert 2 locking nuts **G** into base panel where shown.

Use a screwdriver to turn locking nuts **G** clockwise to lock.

Do not over tighten.

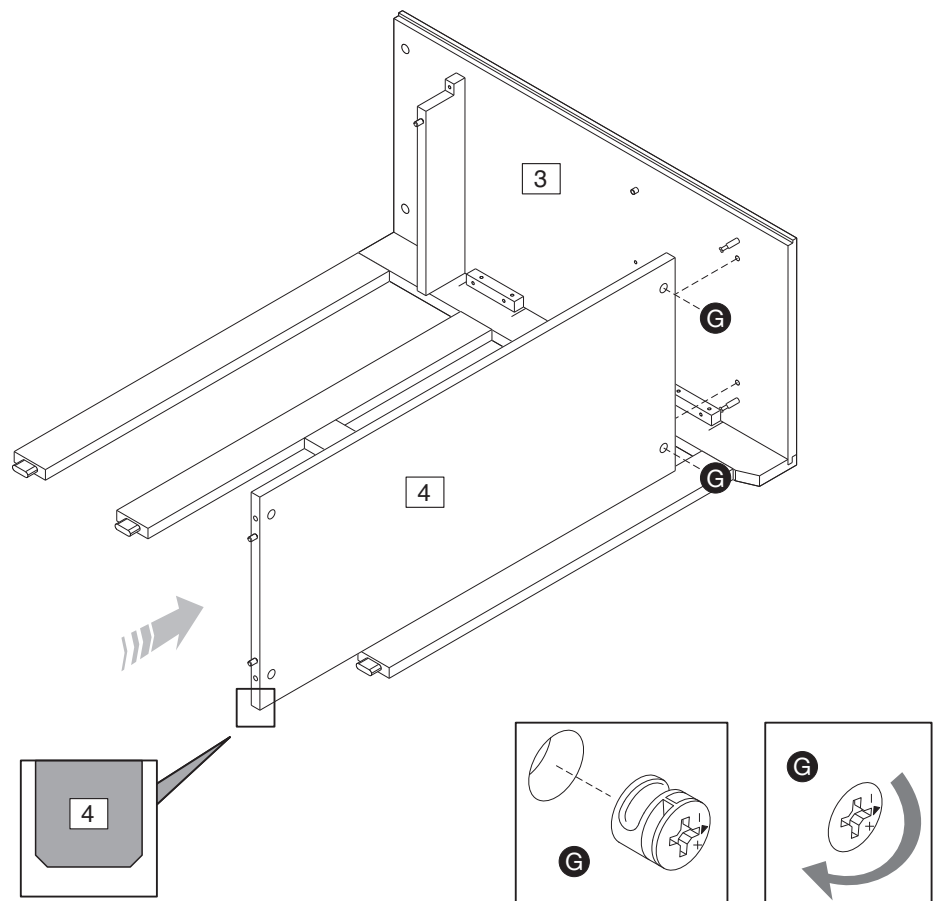

Assembly Instructions

Step 9

Fixing right side panel.

With help, place right side panel **2** properly ensuring dowels and front frames are all fit into their holes at the same time.

Insert 2 locking nuts **G** into base panel where shown.

Use a screwdriver to turn locking nuts **G** clockwise to lock.

Do not over tighten.

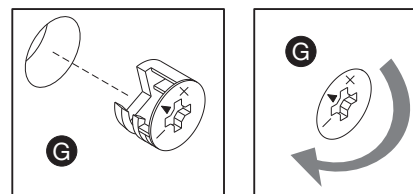
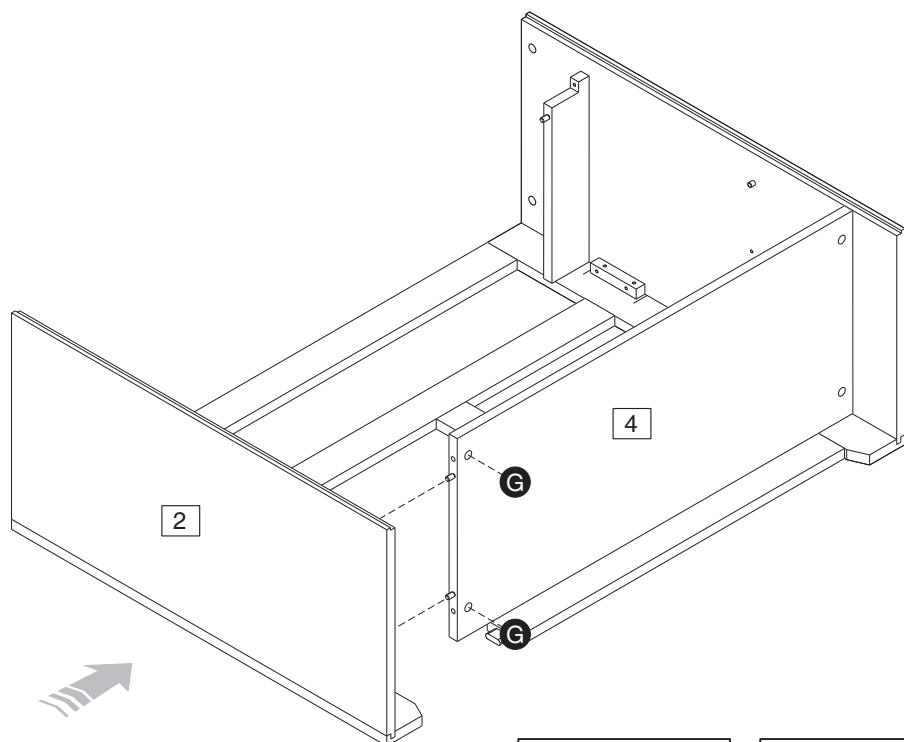

Step 10

Fix metal bracket **M** in the base panel **4** and bottom front frame **10** using screws **B** as shown.

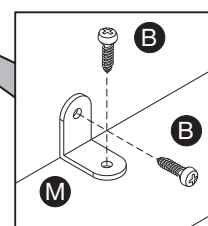
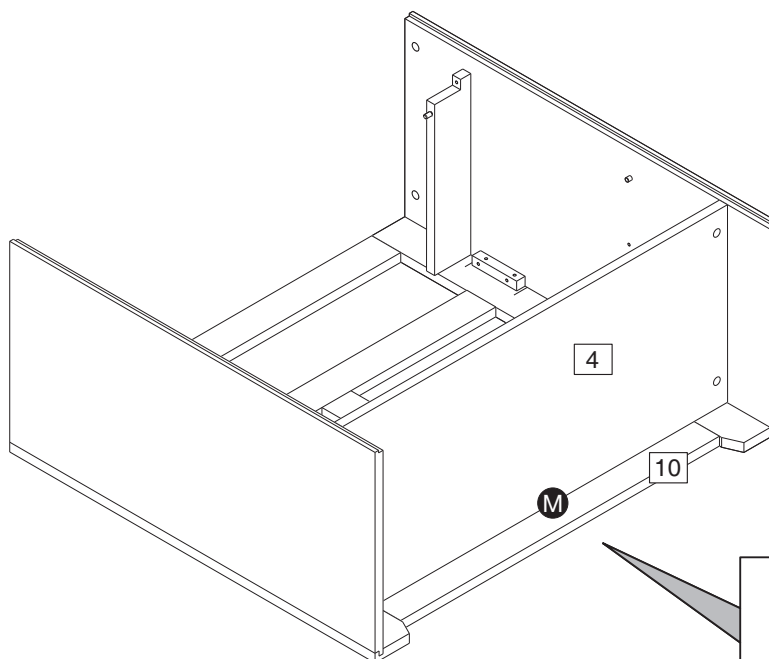

Assembly Instructions

Step 11

Fixing top panel.



Important: With help, carefully stand the product upright.

With help, fit top panel **1** to the cabinet.

Insert 4 locking nuts **G** into side panels where shown.

Use a screwdriver to turn locking nuts **G** clockwise to lock.

Do not over tighten.

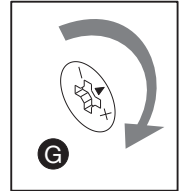
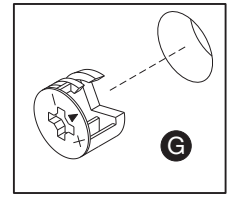
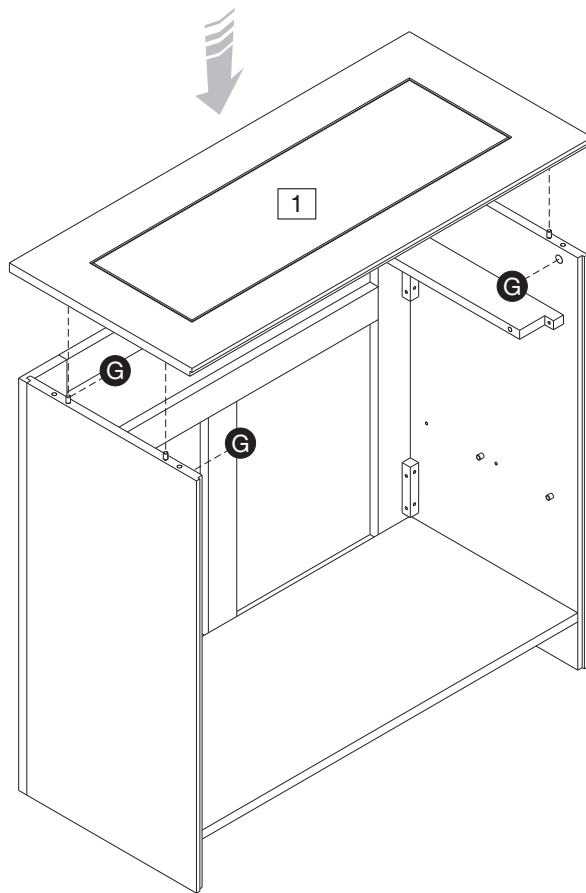

Step 12

Fitting hinges to doors.

Attach hinges **I** in the pre marked holes on doors **15** using screws **B** as shown.

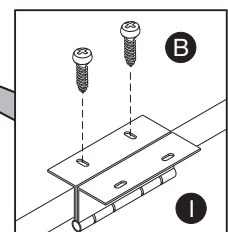
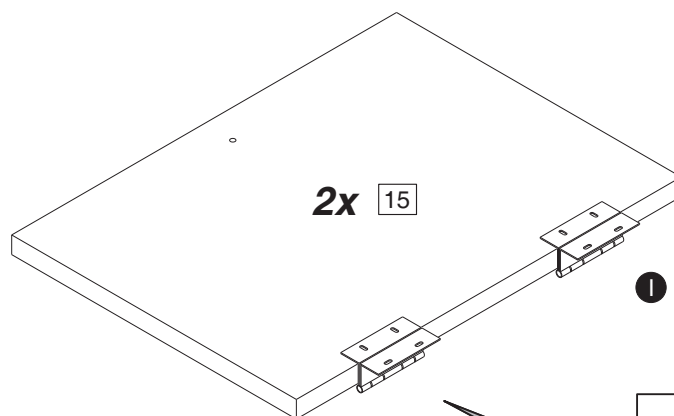

Assembly Instructions

Step 13

Hanging doors.

a: With help, centralise the doors in the opening of the cabinet using the door spacer **Q** to ensure correct spacing, as shown.

b: From inside the cabinet fix the hinges using screws **B** as shown.

 **Note:** To ensure the alignment of the doors is correct, centralise the doors in the opening before attaching to the cabinet.

a:

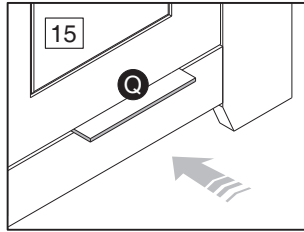

b:

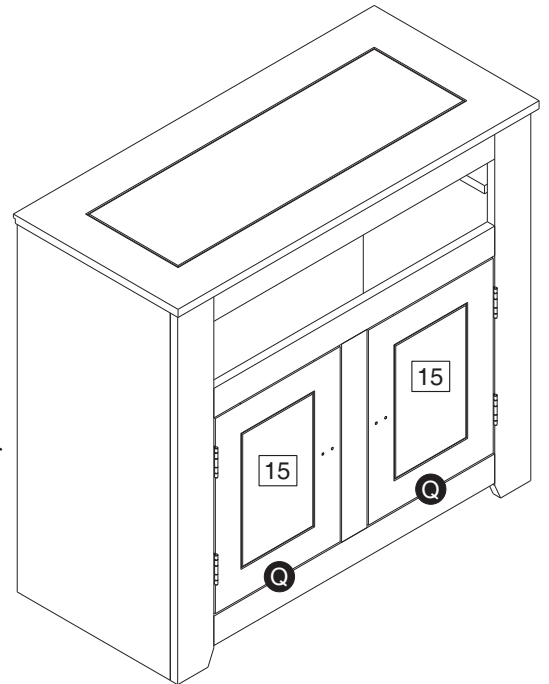
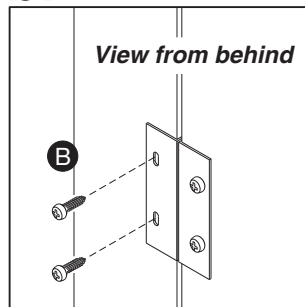

Step 14

Hinge adjustment.

a: To move doors up or down: loosen screws shown and move doors to suit.

Once doors are aligned, re-tighten screws.

b: To move doors left or right: loosen screws shown and move doors to suit.

Re-tighten screws.

a:

View from behind

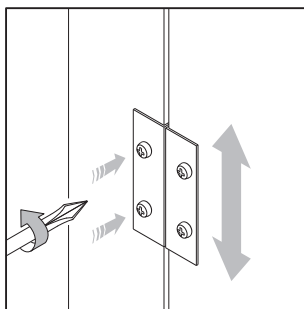

b:

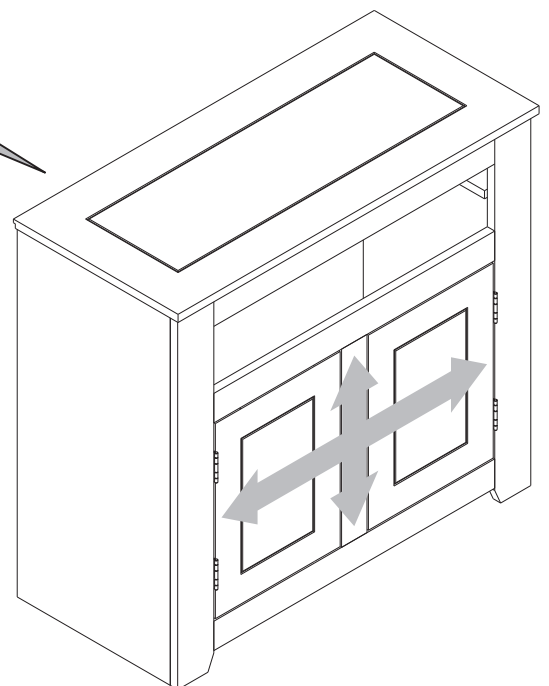
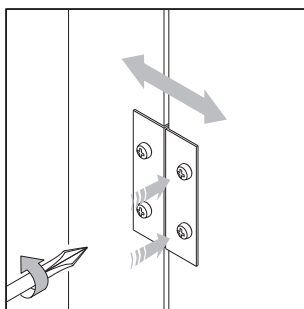

Assembly Instructions

Step 15

Fitting door lock.

a: Screw clip **J** in place using screws **B**. Ensure that the 2 small wheels are flush with the edge of the base as shown in the diagram.

b: Insert plug **K** into clip **J**, ensuring they are leveled as shown in the diagram.

c: Push the door against the plug **K**. This will make 2 small marks on the door as shown in the diagram.

d: The door can then be opened and plug **K** can be screwed into place using the 2 marks made as a guide. This will ensure that the 2 parts of the door clips are lined up correctly.

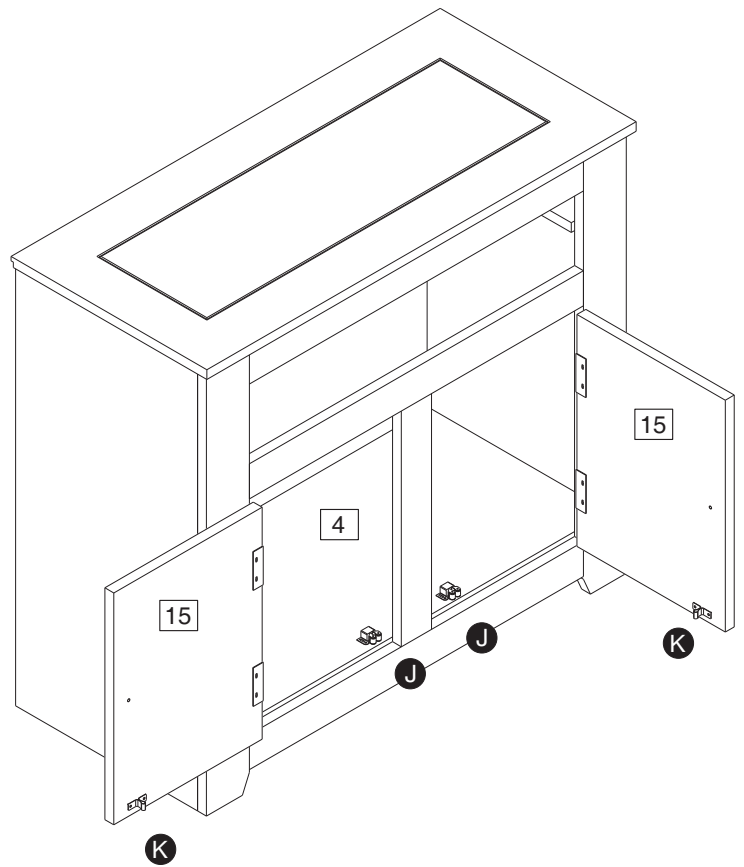

a:

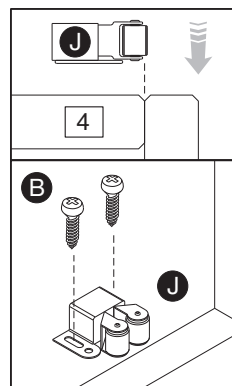

b:

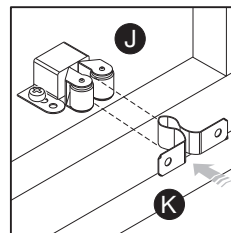

c:

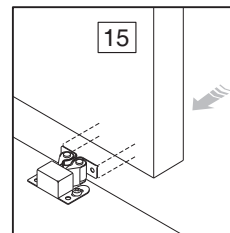

d:

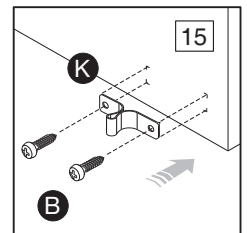

Step 16

Fitting handles to doors.

Attach handles **H** to the doors using bolts **E** as shown.

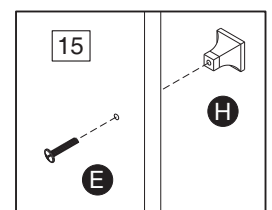
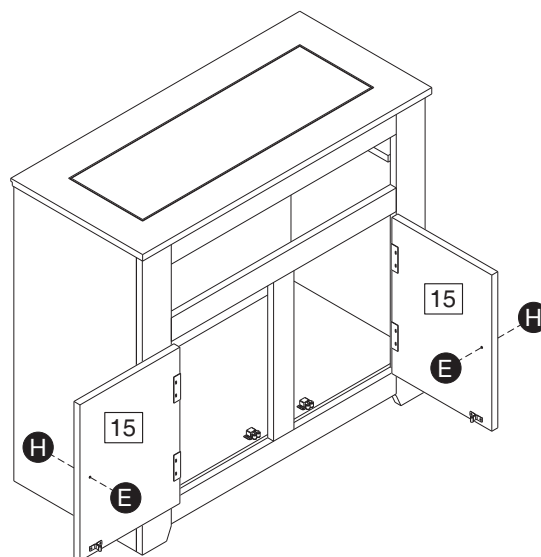

Assembly Instructions

Step 17

Drawer assembly.

a: Attach drawer sides **17** to the drawer front **11** using screws **C**.

b: Slide drawer bottom **14** into slots on drawer sides and position drawer back **12** in place.

c: Holding the drawer back **12**, press the drawer sides and fix them using screws **C**.

d: Using bolts **E** attach drawer handles **H** to drawer front.

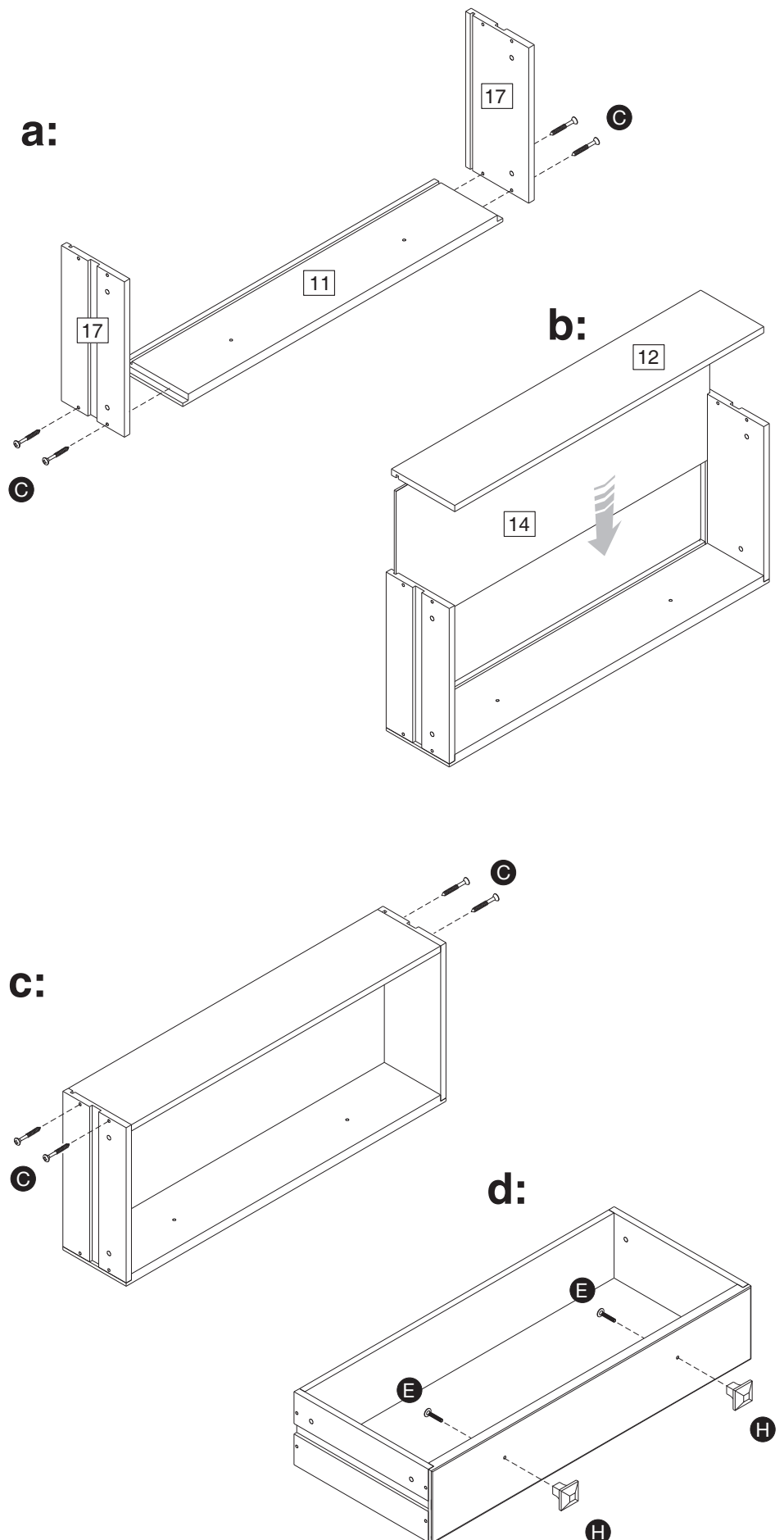

Assembly Instructions

Step 18

Insert drawer into unit. With the back of the drawer past the front frames, use a hammer to tap dowels **A** in flush to drawer sides. This is a safety catch to stop drawer falling out.

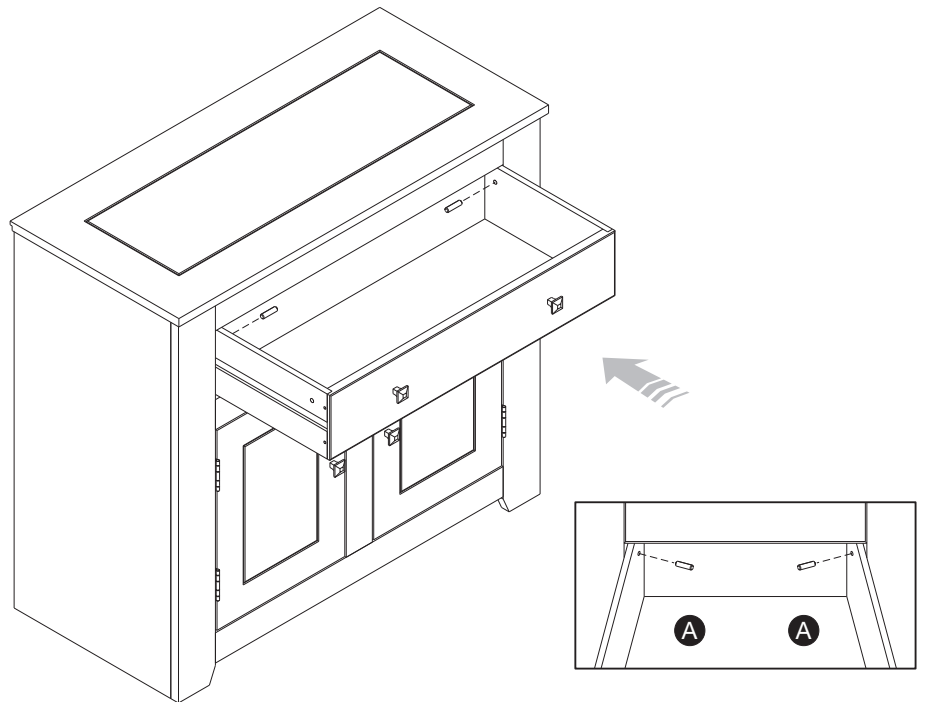

Step 19

Position shelf **5** into place. Make sure round edge is facing front.

Note: This shelf is adjustable it can be placed near the back panel and leave a gap in the front or it can be placed near the doors, leaving a gap in the back.

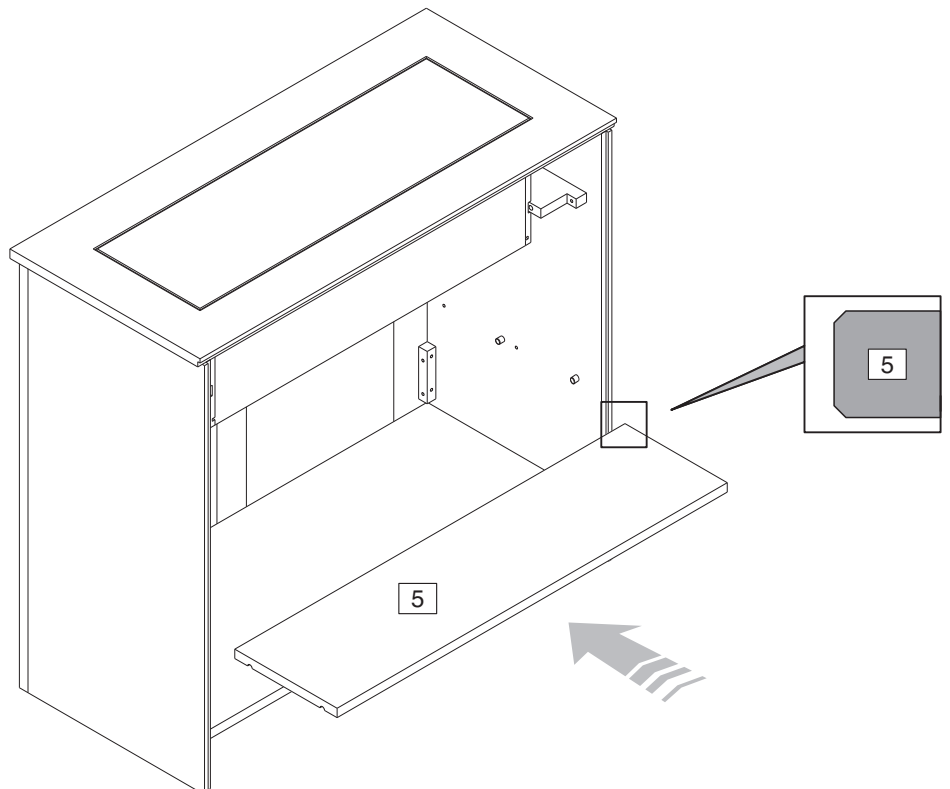

Assembly Instructions

Step 20

Fixing back panels.



Important:

Cabinet **MUST** be 'square' when back panels are attached.

a: Attach back panel **13** at the top first using nails **N**.

b: Position profile **6** onto back panel (just attach).

c: Carefully slot the second back panel **13** into the profile and fix it to the cabinet using nails **N**.

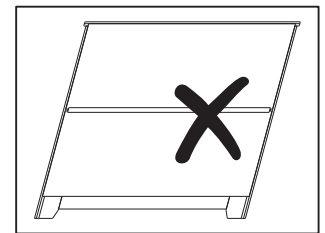
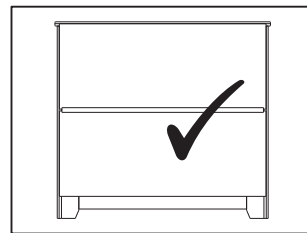
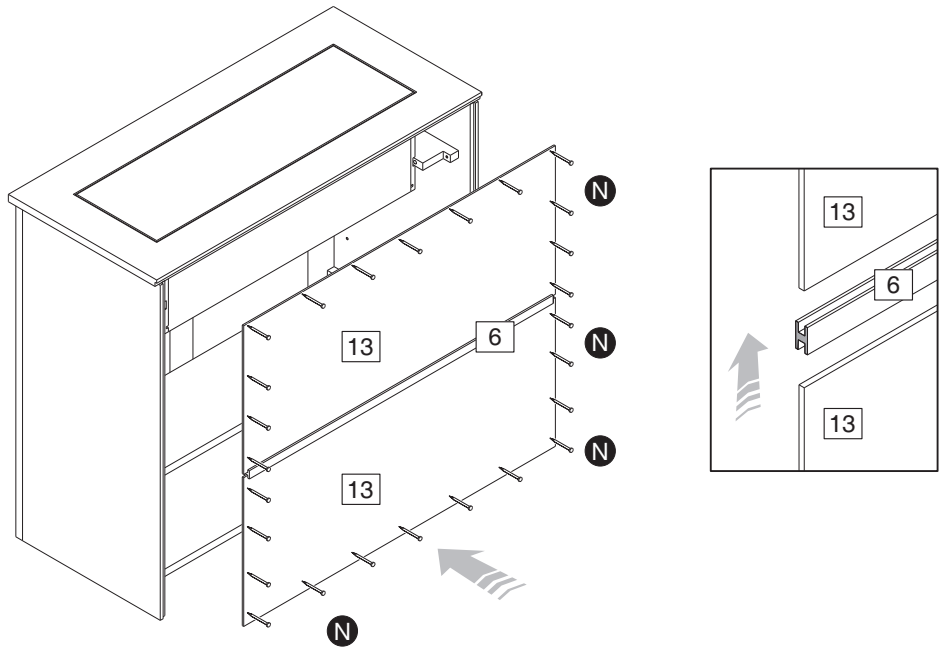

Step 21

Fixing to wall

Furniture must be fixed to a wall.

Fix wall strap **P** to top of furniture using washer **O** and screw **B**.

With help, move furniture into position.

Assembly is complete.

Note: Wall plugs not supplied. The correct type of fixing must be used for your wall, seek professional advice if in doubt.

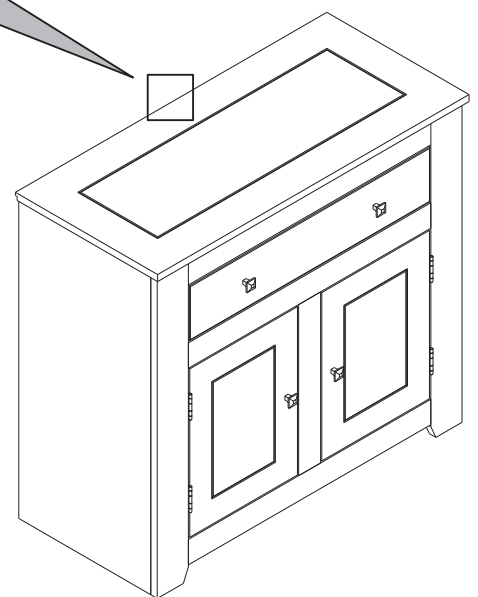
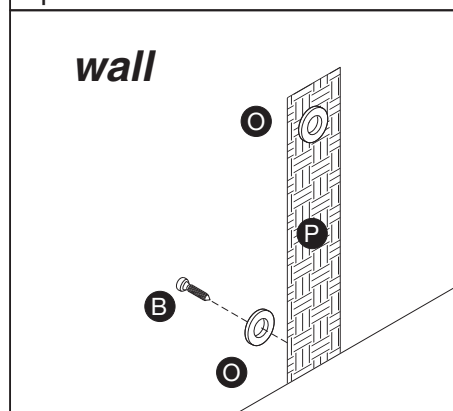

If you need help or have damaged or missing parts, call the **Customer Helpline: 03456 400 800**

A Guide to - Wall Mounting & Fixings

Important note:

If plastic wall plugs are supplied with your product:



- these are only suitable for use in masonry walls.

If you are in any doubt about the correct wall plugs for your wall, seek professional advice.

Failure of the product due to using incorrect fixings is the responsibility of the installer.



Important: When drilling into walls always check that there are no hidden wires or pipes etc.

Make sure that the screws and wall plugs being used are suitable for supporting your unit. Consult a qualified tradesperson if you are unsure.

Hints:

- 1: **General rule:**  Always use a larger screw and wall plug if you are not sure.
- 2: Ensure you use the recommended drill bit to match the wall plug and hole size.
- 3: Ensure you drill the hole horizontally, do not force the drill or enlarge the hole.
- 4: Take extra care when drilling high walls, ceilings and ceramic tiles. Ensure wall plugs are inserted beyond the thickness of the ceramic tiles to avoid the tiles splitting or cracking.
- 5: Ensure wall plugs are well fitted and are a tight fit in the drilled hole.

Types of walls

You can use one of the following types of wall plug if your walls are made of brick, breeze block, concrete, stone or wood.

No.1 "General Purpose" wall plug

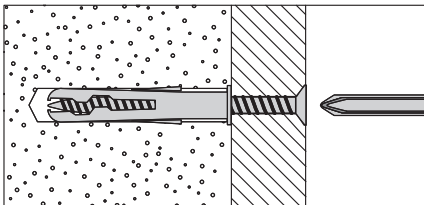

Generally aerated blocks should not be used to support heavy loads, use a specialist fitting in this case. For light loads, general purpose wall plugs can be used.

No.2 "Plasterboard" wall plug

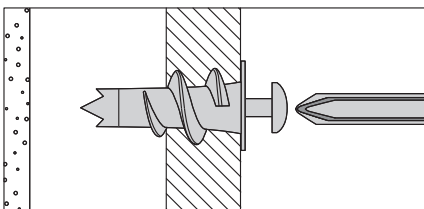

For use when attaching light loads on to plasterboard partitions.

No.3 "Cavity Fixing" wall plug

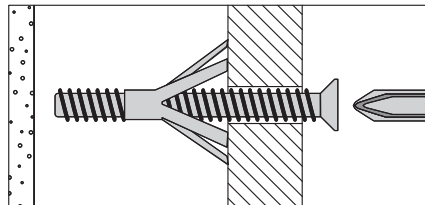

For use with plasterboard partitions or hollow wooden doors.

No.4 "Cavity Fixing-Heavy Duty" wall plug

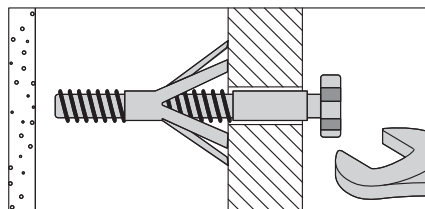

For use when fitting or supporting heavy loads such as shelving, wall cabinets and coat racks.

No.5 "Hammer Fixing" wall plug

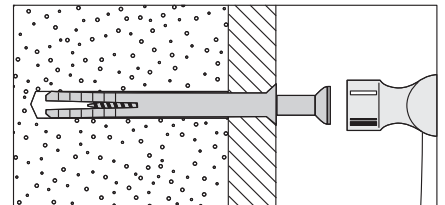

For use with walls stuck with plasterboard. The hammer fixing allows it to be fixed to the wall rather than the plasterboard. Always check the fixing is secure to the retaining wall.

No.6 "Shield Anchor" wall plug Heavy loads

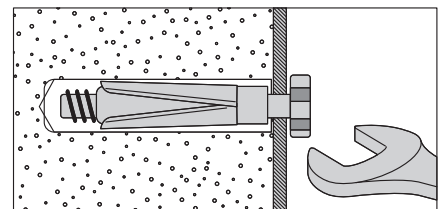

For use with heavier loads such as TV & HiFi speakers and satellite dishes etc.



Care & Maintenance

Safety: Always check the fitting and location to ensure your safety in and around the home.

Fitting: From time to time check the fitting to ensure the wall plugs or screws do not become loose.

Your 1 Year Guarantee

Peace Of Mind

Knowing Your Furniture Is Protected

Protection received within the Manufacturer's Guarantee	Optional Added Protection with Furniture Care
Covers you for manufacturing defects for 1 year.	Covers you for up to 2 years for specific structural defects following the expiry of the manufacturer's guarantee.
In the event of a problem within this time please call 0345 640 0800 , or visit an Argos store. Please retain your receipt and order number as proof of purchase.	Plus - covers you for accidental damage up to 3 years for incidents such as household spills, rips, tears and burns. Accidental damage cover begins from the moment your plan starts.
	If you want to purchase Furniture Care visit https://argos.productaftercare.co.uk or go into an Argos store
Key exclusions applying to both the Manufacturer's Guarantee and Furniture Care include where the fault is due to misuse, abuse, deliberate damage, wear and tear, neglect, use in contravention with the instructions, or if the product has been the subject of unauthorised alterations or commercial use (for full list of exclusions please visit https://argos.productaftercare.co.uk or visit an Argos store for more information). You have up to 45 days post purchase to take out Furniture Care. Terms and conditions apply. Your statutory rights remain unaffected.	

Register

For Your Manufacturer's Guarantee

Thank you for choosing Argos Home.

We hope you love your shiny new things!

To provide you with the best possible after sales service, don't forget to visit **<https://argos.productaftercare.co.uk>** where you can **register** for your guarantee.

Once you've registered, you can upload your receipt to store safely online, alongside details of our after sales support service, ready at hand should you need it.

You can also take out Furniture Care which protects you against accidental damage, from the moment you take the plan out, to keep your new furniture looking newer for longer.

Register Today

<https://argos.productaftercare.co.uk>