

# BUSH

## Instruction manual

CTV401



You'll soon be enjoying your new TV.

It all begins here, with your instructions. Don't worry, there's nothing too technical coming up. Just simple, step-by-step guidance to get you up and running quickly. Sound good? Then let's get started.

## Help and Guidance

We're here to help you get the most from your TV. Should you require any guidance, a simple solution can often be found online at:

**[www.argos-support.co.uk](http://www.argos-support.co.uk)**

If you still require further assistance, call one of our experts on **0345 604 0105**.

# Contents

## 1 Safety information

Safety information	8
--------------------	---

## 2 Getting to know your TV

Ready? Let's begin	12
Accessories	12
Remote control	13
Side panel	14
Rear panel	15
Installing the remote batteries	16
Remote control information	16
Installing the stand feet	17
Vesa mounting	17

## 3 Connections

Making the video and audio connections	20
Connect an AV device (HDMI cable)	20
Connect a computer with a VGA cable	21
Connect an AV device (Component cable)	22
Connect an AV device (SCART cable)	22
Connect an AV device (Composite cable)	23
Connect a digital audio receiver	23
Connecting headphones	24

## 4 Standard features

Turning on the TV for the first time	26
Selecting the input source	27
Channel selection	27
Display channel information	27
Volume adjustment	27
Using the electronic program guide	27

## 4 Standard features

### PVR recording

Recording a current show	28
Recording a future show	28
PVR schedule list	28

### Picture settings

Picture mode	29
Contrast	29
Brightness	29
Colour	29
Sharpness	29
Colour temperature	29
Aspect ratio	29
Noise reduction	29
Aspect ratio's explained	30

### Sound settings

Sound mode	31
Treble	31
Bass	31
Balance	31
Auto volume	31
Digital output mode	31
Audio description	31
AD volume	31
Audio language	31

# Contents

## Channel settings

Channel setting (TV, DTV or Radio)	32
Auto tuning	32
Analogue manual tuning	32
DVB-T manual tuning	33
Channel edit	33
Signal information	33
CI information	33
Recorded list	34
Schedule list	34

## Lock settings

Lock system	34
-------------	----

## Time settings

Auto sync	35
Clock	35
off time	35
On time	35
Sleep timer	35
OSD timer	35
Auto standby	35
Time zone	36

## Network settings

IP configuration	36
Network info	36
Network test	36

## Setup settings

Language	37
Audio language	37
Subtitle language	37
Hearing impaired	37
Blue screen	37
PVR file system	37
First time installation	37
Software update (USB)	37
Software update (NET)	37
Version info	37

## PC settings

Auto adjust	38
Horizontal position	38
Vertical position	38
Size	38
Phase	38

## 5 Advanced features

Connecting a USB storage device	40
Multimedia interface	41
Movie operation	41
Photo operation	42
Music operation	42
Supported multimedia formats	43

# Contents

## 6 Other information

Technical specification	46
Display modes	46
Care & maintenance	48
Disc handling	48

## 7 Product support

Troubleshooting	50
Help and assistance	53
Disposal	54
Guarantee	55

This page is left intentionally blank

# Safety information

1

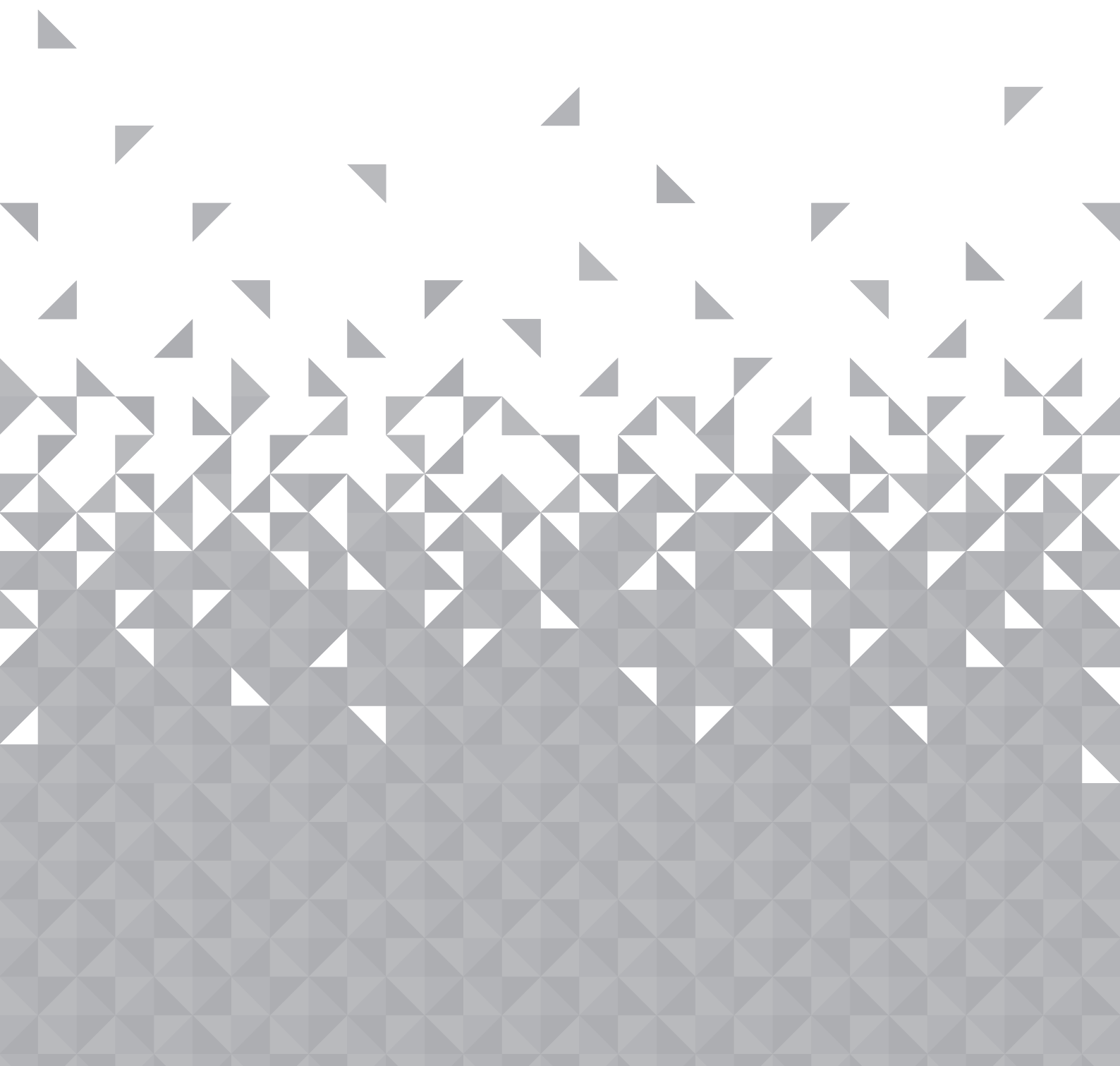



## Safety information

**Important** - Please read these instructions fully before installing or operating

### Power source



- This symbol means that this unit is double insulated. An earth connection is not required.
- The appliance must be connected to a 100-240 volt 50/60Hz AC supply by means of a three pin socket.
- Unplug this apparatus during lightning storms or when unused for long periods of time - to prevent damage to this product.



- Opening or removing covers may expose you to dangerous voltages or other hazards.



- To prevent risk of fire or electric shock, avoid overloading wall outlets, extension cords, or integral convenience receptacles.

- Use suitable power sources - Plug the product into a suitable power source, as described in the operating instructions or as marked on the product.

- The supply voltage should be the same as that indicated in the technical specifications and the appliance rating plate.

- If the socket outlets in your home are not suitable for the plug supplied with this unit check with a qualified electrician for replacement.

- In order to disconnect the apparatus from the mains completely, switch off the outlet and remove the mains plug completely.



- Do not bend, stretch or pull the supply cable in order to avoid electric shock.
- When installed, the power socket must be within easy reach.
- Do not install the unit in a confined space. Allow adequate ventilation to prevent heat build-up.
- For indoor use only.

### Moisture and water

- Do not use this apparatus near water or moisture.
- Do not use this product near a bathtub, wash bowl, kitchen sink, and laundry tub, in a wet basement, near a swimming pool, or anywhere else that water or moisture is present.

### Heat sources and flames



- Batteries shall not be exposed to excessive heat such as sun, fire or the like
- To prevent risk of fire or electric shock, avoid overloading wall outlets, extension cords, or integral convenience receptacles.

### Servicing and repairs

- Refer all servicing to qualified service personnel
- Servicing is required when the apparatus has been damaged in any way: such as liquid has been spilled or objects have fallen into the apparatus; the apparatus has been exposed to rain or moisture, does not operate normally, or has been dropped.

### Temperature



- Avoid extreme degrees of temperature either hot or cold. Place the unit well away from heat sources such as radiators or gas/ electric fires.
- Avoid exposure to direct sunlight and other sources of heat.

If you require any technical guidance or find that your product is not operating as intended, a simple solution can often be found in the **Troubleshooting** section of these instructions,





## Safety information

**Important** - Please read these instructions fully before installing or operating

### Location of unit



- The unit must be placed on a flat stable surface and should not be subjected to vibrations.
- Do not place the unit on sloped or unstable surfaces as the unit may fall off or tip over.
- The mains socket must be located near the unit and should be easily accessible.
- This unit is designed for indoor use only.

### Ventilation



- To prevent the risk of electric shock or fire hazard due to overheating, ensure that curtains and other materials do not obstruct the ventilation vents.
- Do not install or place this unit in a bookcase, built-in cabinet or in another confined space. Ensure the unit is well ventilated.
- Make sure that there is a gap of at least 10cm on both sides and a gap of 20cm at the top.

### Interference

- Do not place the unit on or near appliances which may cause electromagnetic interference. If you do, it may adversely affect the operating performance of the TV, and cause a distorted picture or sound.

This page is left intentionally blank

# Getting to know your TV 2

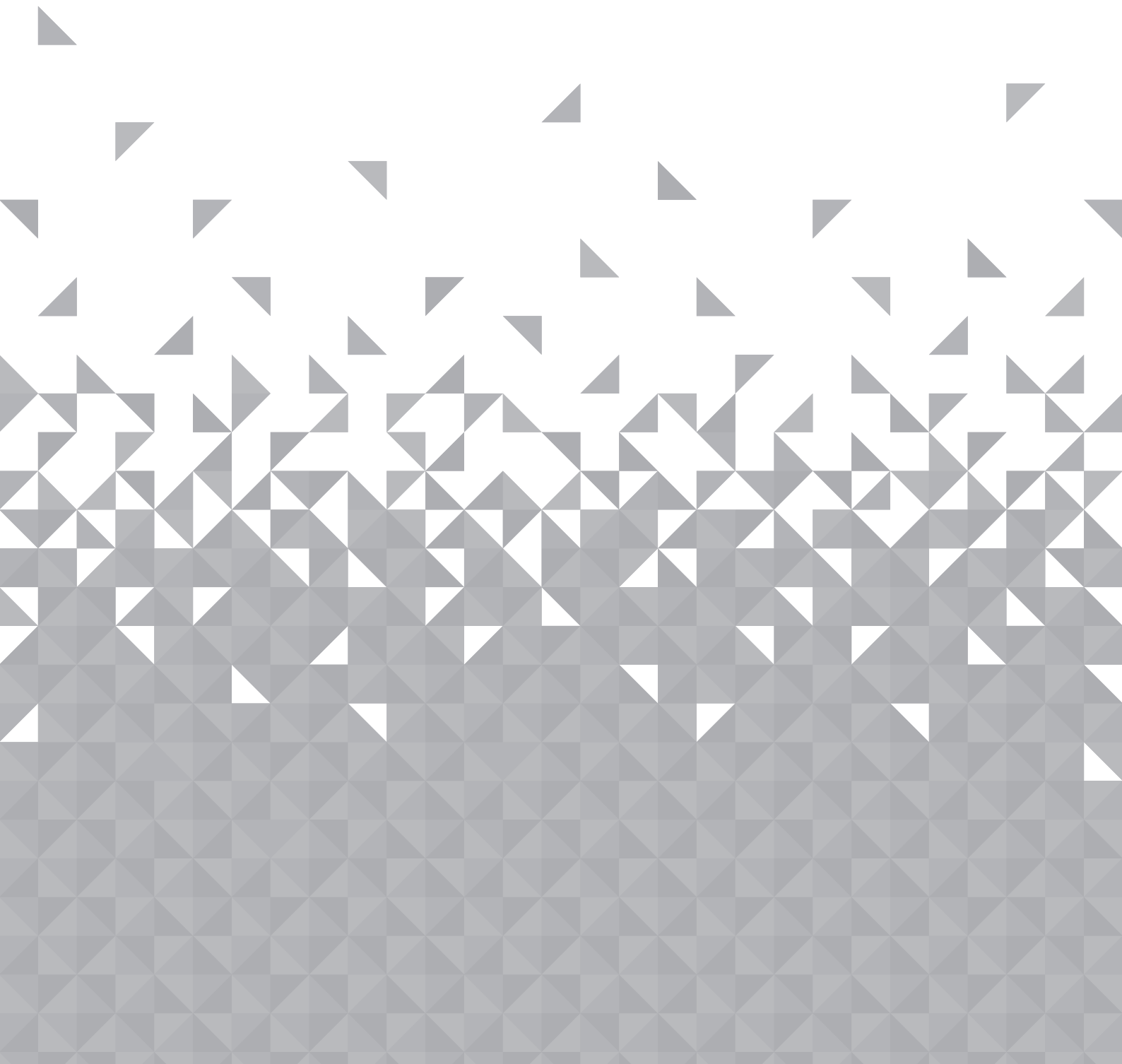

# Getting to know your TV

You'll be up and running in no time

## Ready? Let's begin...

Please read these instructions carefully. They contain important information which will help you get the best from your TV and ensure safe and correct installation and operation.

If you require any further assistance, our technical experts are happy to help. For full details, refer to the product support section at the end of these instructions.

## Accessories

1. CTV401 TV
2. 2 x TV stand feet
3. 4 x stand fixing bolts
4. Remote control
5. 2 x AAA batteries
6. Instruction manual
7. Quick setup guide

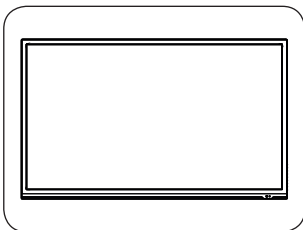

TV

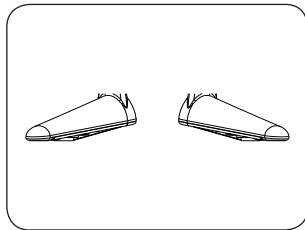

Stand feet

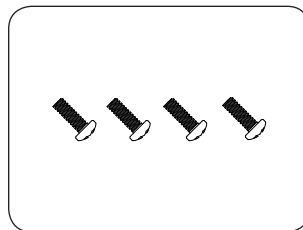

4 x screws (M4 x 12)

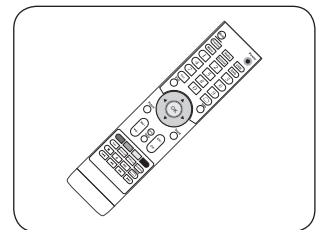

Remote control

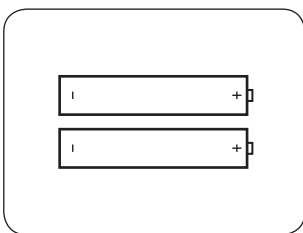

2 x AAA batteries

If you require any technical guidance or find that your product is not operating as intended, a simple solution can often be found in the **Troubleshooting** section of these instructions.

# Getting to know your TV

You'll be up and running in no time

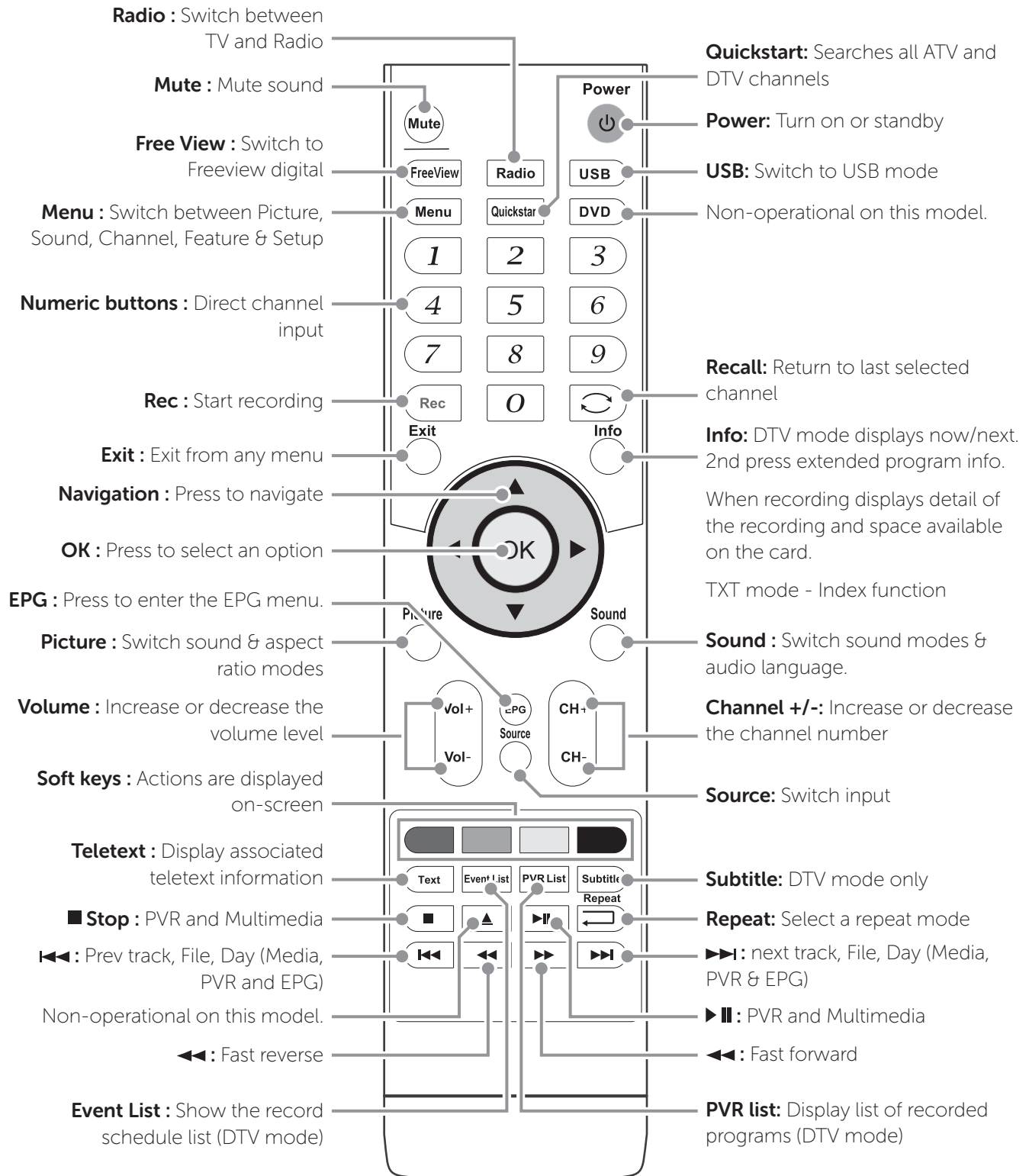

or online at [www.argos-support.co.uk](http://www.argos-support.co.uk) If you still require further assistance, call one of our experts on 0345 604 0105.

# Getting to know your TV

You'll be up and running in no time

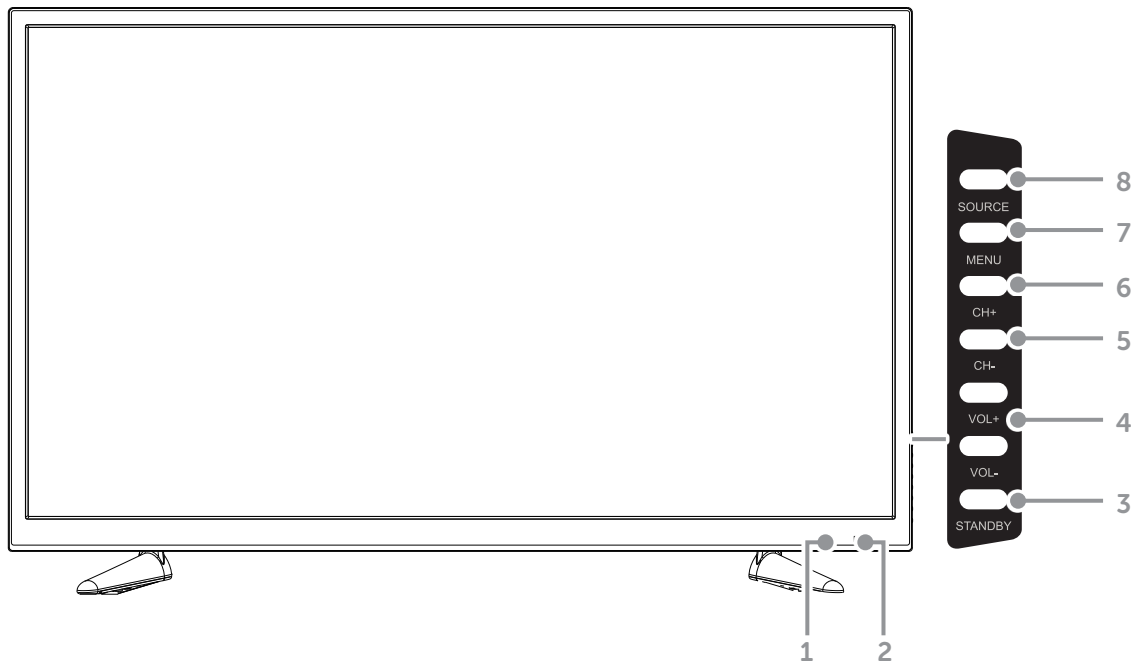

Item	Description
<b>1. Power LED</b>	<p>Illuminates green when the TV is turned on. Illuminates red when the TV is in standby mode.</p> <p>The LED will alternate between red and green when the PVR timer programming has started in the standby mode.</p>
<b>2. IR (infrared receiver)</b>	<p>Receives IR signals from the remote control.</p> <p>Do not place anything in front of the sensor, as its function may be affected.</p>
<b>3. Standby</b>	Switches the TV on or off from standby mode.
<b>4. Vol + / -</b>	Adjust the volume level. Press to select and adjust a setting in the OSD menu.
<b>5. CH -</b>	Press to select a channel or select a sub-menu from the OSD menu.
<b>6. CH +</b>	Press to select a channel or select a sub-menu from the OSD menu.
<b>7. Menu</b>	Displays the OSD (On Screen Display) menu.
<b>8. Source</b>	<p>Press to select the various input signal sources.</p> <p>DTV, ATV, COMPOSITE-AV, SCART, VGA-PC, YPBPR (COMPONENT), HDMI1, HDMI2 and HDMI3.</p> <p>Confirm a selection on the OSD menu.</p>

If you require any technical guidance or find that your product is not operating as intended, a simple solution can often be found in the **Troubleshooting** section of these instructions,

# Getting to know your TV

You'll be up and running in no time

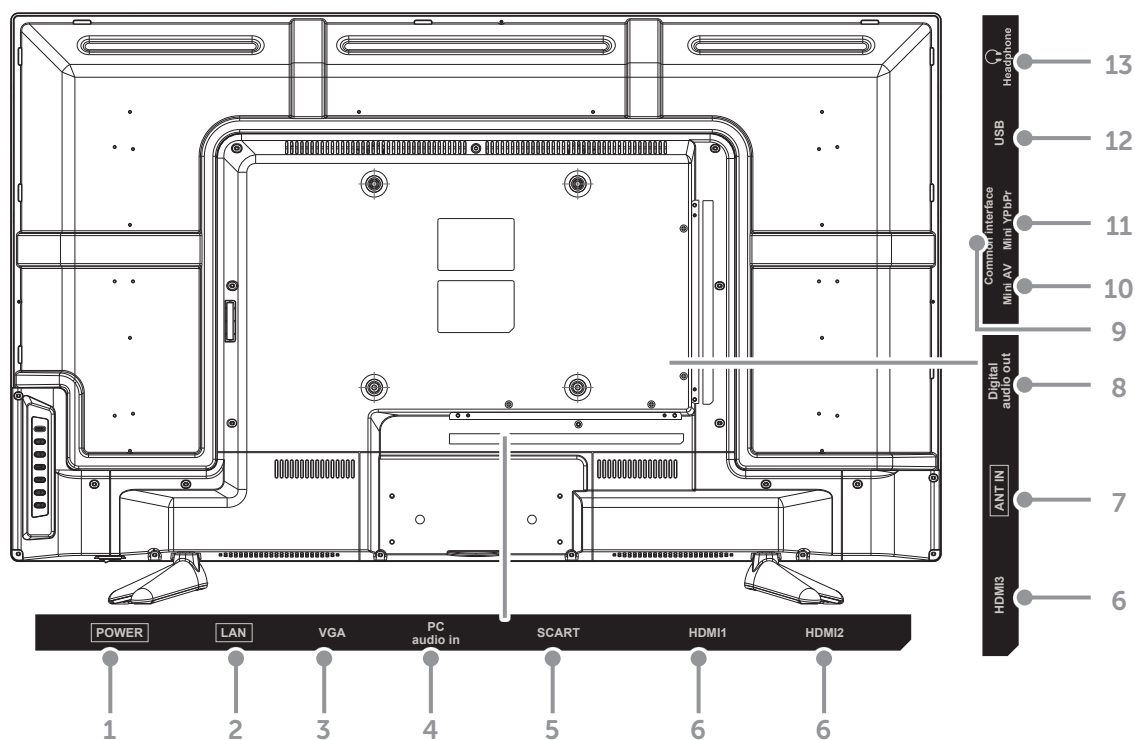

Socket	Description
<b>1. Power</b>	Connect the mains power cable.
<b>2. LAN</b>	Connect to a LAN port
<b>3. VGA input</b>	Connect a PC to this input.
<b>4. PC Audio input</b>	Connect audio from a PC when using the VGA video input socket.
<b>5. SCART input</b>	Connect a VCR, DVD player or other AV devices with a SCART output socket.
<b>6. HDMI inputs</b>	Connect to a high definition (HD) signal output device, such as a set-top box, Blu-ray disc player or AV receiver.
<b>7. TV Antenna input</b>	Connect to the antenna/ aerial socket on the wall with an RF coaxial cable.
<b>8. Digital audio out (optical)</b>	Connect to a digital audio socket on a 5.1 audio system.
<b>9. CI Slot</b>	Connect a common interface subscription card if used.
<b>10. MINI AV</b>	Connect to the composite VIDEO and AUDIO (L/R) output sockets on an external video device.
<b>11. MINI YPBPR / Audio L/R</b>	Connect to a DVD player, Digital set-top box or other AV devices with a component (YPbPr) video and audio output sockets.
<b>12. USB</b>	Connect a USB storage device to allow playback of videos, audio, photos and text files (media mode) and record DTV programmes on to the USB storage device.
<b>13. Headphone output</b>	Connect earphones.

or online at [www.argos-support.co.uk](http://www.argos-support.co.uk) If you still require further assistance, call one of our experts on 0345 604 0105.

# Getting to know your TV

You'll be up and running in no time

## Installing batteries in the remote

1. Press and lift the back cover to open the battery compartment of the remote control.

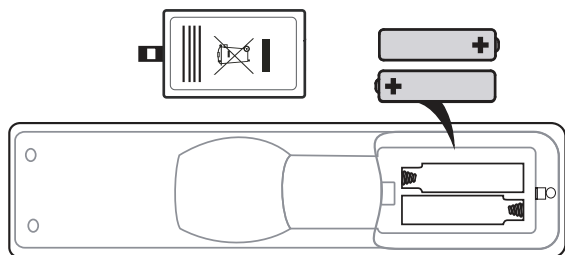

2. Insert 2 x 1.5 AAA size batteries. Make sure to match the (+) and (-) ends of the batteries with the (+) and (-) ends indicated in the battery compartment.
3. Close the battery compartment cover.

## Handling the batteries

- Improper or incorrect use of batteries may cause corrosion or battery leakage, which could cause fire, personal injury or damage to property.
- Only use the battery type indicated in this manual.
- When the batteries are exhausted, the remote will not function. Replace both batteries at the same time with new ones.
- Do not install new batteries with used ones and do not mix different types of batteries.
- Do not dispose of used batteries as domestic waste. Dispose of them in accordance with local regulations.

## Handling the remote control

- Take care of your fingernails when pressing and holding the battery release tab.
- Do not drop or cause impact to the remote control.
- Do not spill water or any liquid on the remote control.
- Do not place the remote control on a wet object.
- Do not place the remote control under direct sunlight or near sources of excessive heat.
- Remove the batteries from the remote control when not in use for a long period of time, as it could cause corrosion or battery leakage and may result in physical injury and/ or damage of property including fire.

## Remote control operation range

Point the remote control at the TV no more than 5 meters from the remote control sensor on the TV and within 60° in front of the TV. The operating distance may vary depending on the brightness of the room.

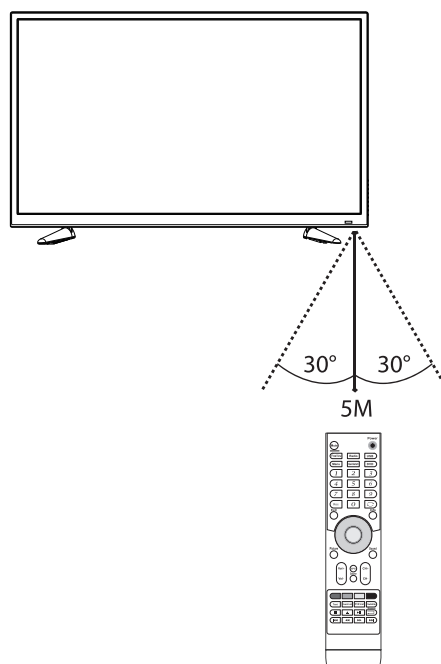

If you require any technical guidance or find that your product is not operating as intended, a simple solution can often be found in the **Troubleshooting** section of these instructions,



# Getting to know your TV

You'll be up and running in no time

## Installing the stand feet

Place the TV face down on a soft and flat surface (blanket, foam, cloth etc) to prevent damage to the TV.

1. Attach the stand feet in the positions shown and secure them with the supplied screws (M4 x 12).

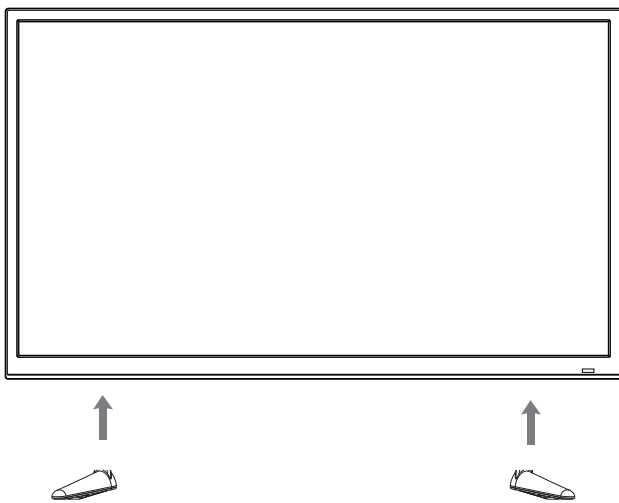

## VESA mounting

This unit is VESA-compliant and designed to be wall mounted with a VESA-compliant 200 x 200mm mounting kit.

Mount the unit according to the instructions of the wall bracket (not supplied)

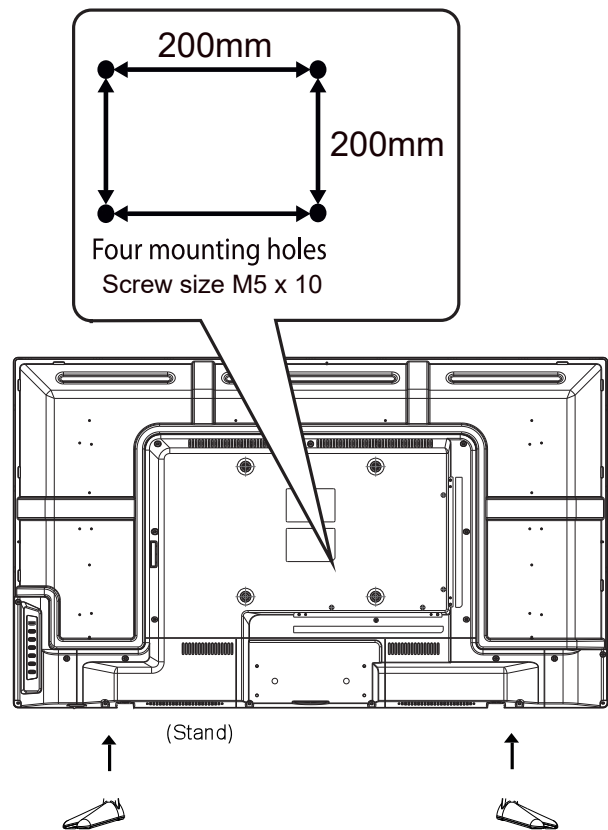

This page is left intentionally blank

# Connections 3

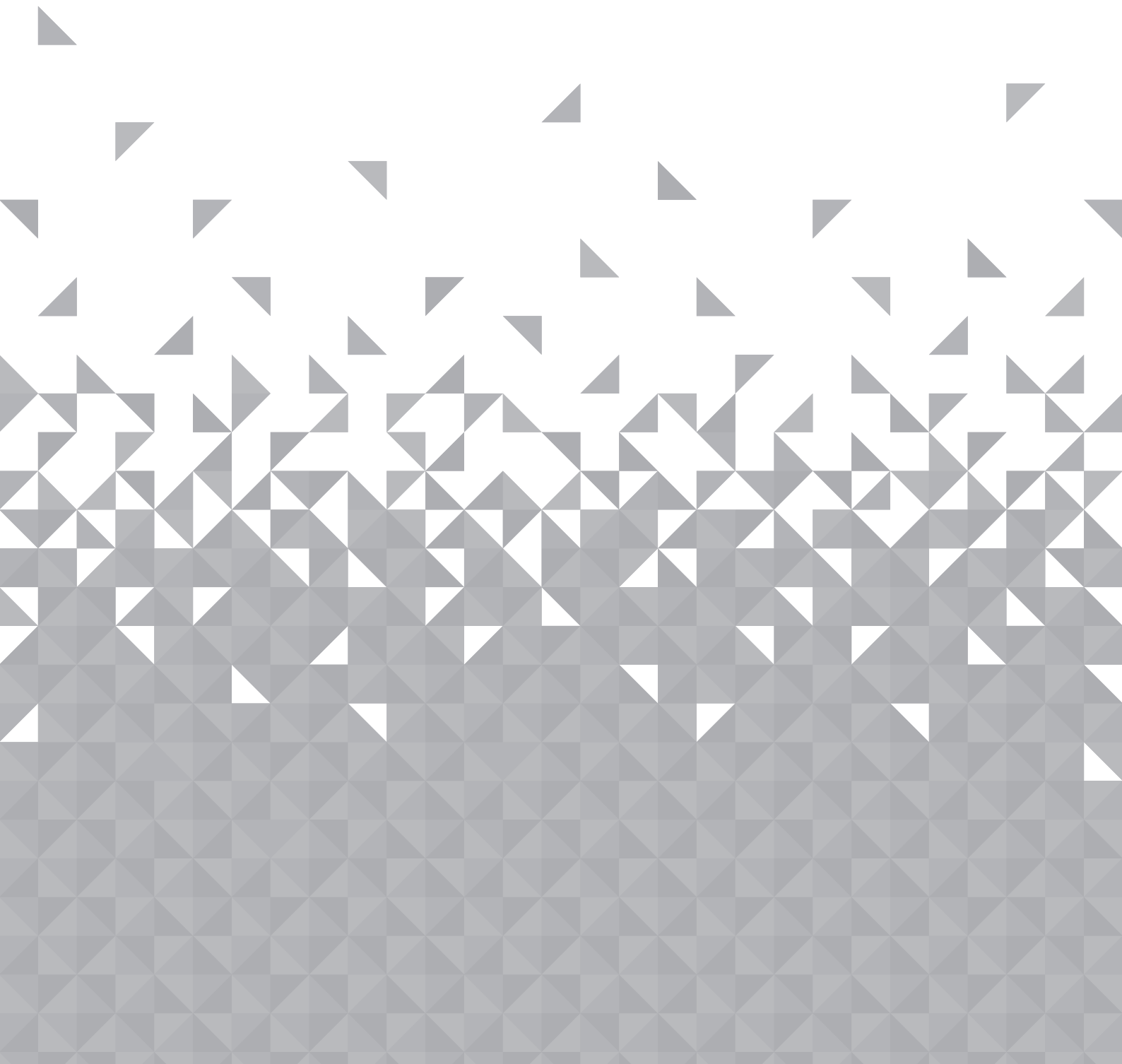

# Connections

Bringing it all together

## Making the video and audio connections

Not all AV devices have the ability to connect to a TV. Please refer to the owners manual of your AV device for compatibility and connection procedures.

When connecting any external AV device, do not connect the mains cable to the mains socket until all the connections are complete.

Best video performance	Connection	Signal type	Separate audio connection required
	 HDMI	HDMI (480i/480p/576i/576p/720p/1080i/1080p)	No
	 VGA	PC	 PC audio
	 Mini YPbPr	Component video (480i/480p/576i/576p/720p/1080i/1080p)	 Mini AV
	 SCART	SCART (RGB input)	No
	 Mini AV	Composite video	No

## Connecting an AV device with an HDMI cable

- This TV can accept High-Definition Multimedia Interface (HDMI) and supports HDCP (High-Bandwidth Digital Content Protection) protocol.
- The TV has a total of 3 HDMI input sockets. Please make sure the correct input source is selected corresponding to your connected HDMI input socket.
- When you connect to the output of a HD ready player (Blu-ray player, game console, set-top box or computer) switch to the HDMI function and the TV will automatically detect the resolution used by the HDMI source.
- To get the best picture quality, adjust the Blu-ray player, game console, set-top box or computer resolution up to 1920 x 1080P.



If you require any technical guidance or find that your TV is not operating as intended, a simple solution can often be found in the **Troubleshooting** section of these instructions,

# Connections

Bringing it all together

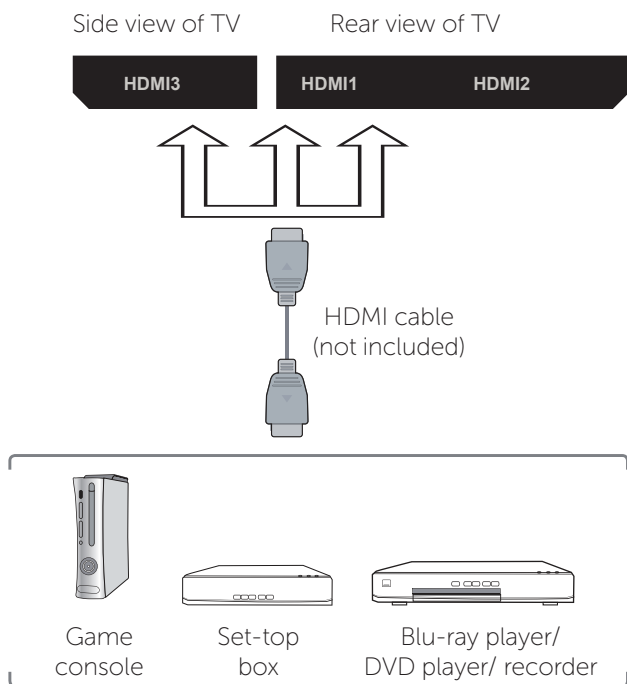
## Connecting an AV device with an HDMI cable (continued)





1. Use an HDMI cable to connect the TV's HDMI input socket to the external AV device's HDMI output socket.
2. Plug the connected device(s) into the mains socket.
3. Press the STANDBY button on the TV or the  button on the remote control to turn on your TV.
4. Press the SOURCE button on the TV or remote control to display the source list. Use the   buttons to select HDMI 1/2/3 and then press the OK button to confirm.

Although this TV is able to connect to an HDMI device, it is possible that some devices may not operate correctly.

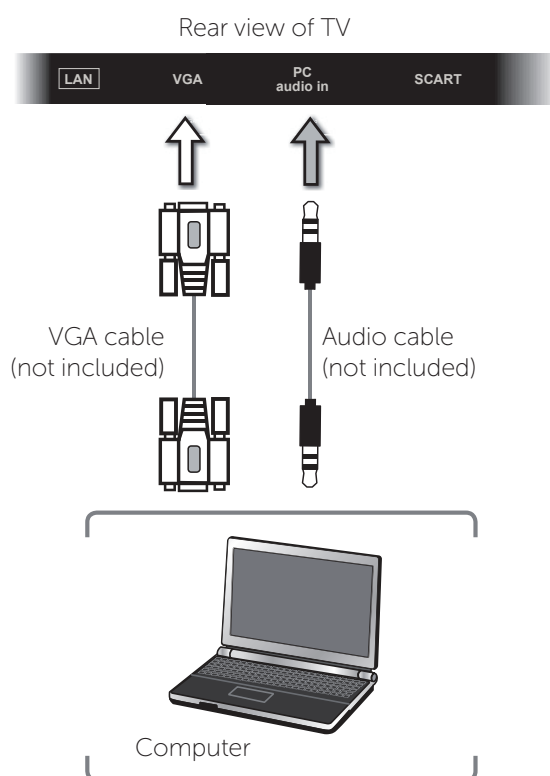
## Connecting a computer with a VGA cable



1. Use a VGA cable to connect the TV's PC input socket to a computer's VGA output socket. Use an audio cable to connect the TV's PC AUDIO input socket to the computer's audio output socket.
2. Plug the connected devices into the mains socket.
3. Press the STANDBY button on the TV or the  button on the remote control to turn on your TV.
4. Press the SOURCE button on the TV or remote control to display the source list. Use the   buttons to select PC and then press the OK button to confirm.



- The best resolution is 1920 x 1080
- If your computer is set to shut down after a few minutes of idle mode, the TV will also switch to standby mode due to no signal being received. This is to save energy. Press the STANDBY button on the right side of the TV when viewed from the front or the  button on the remote control to restart the TV.

# Connections

Bringing it all together

## Connecting an AV device with a component (YPbPr) cable

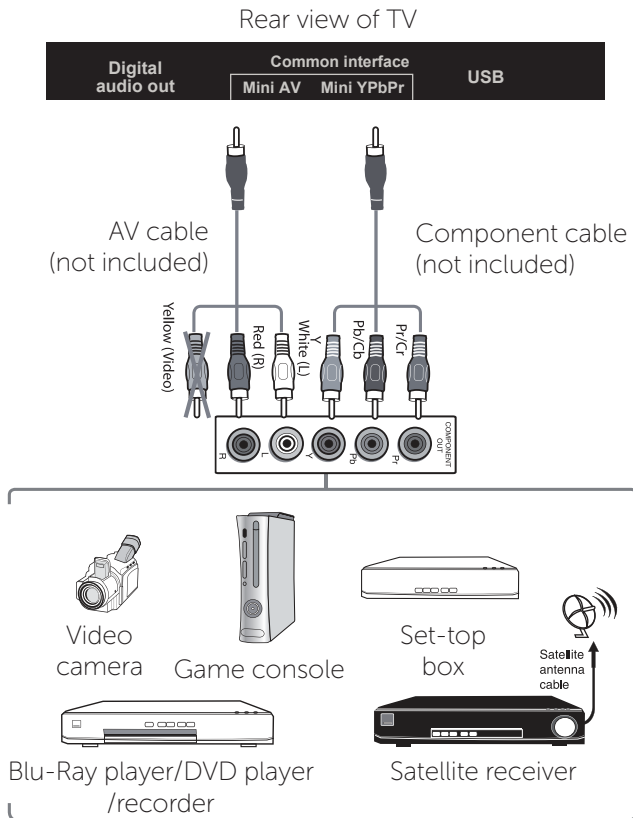

1. Use a component cable to connect the TV's MINI YPbPr input sockets to an external AV devices component output sockets.
2. Use an AV cable to connect the TV's MINI AV input socket to the external AV device's component audio output sockets. (Audio left = white and Audio right = red).

Component port on the TV	Mini YPbPr		
Video output ports on DVD player	Y	Pb	Pr
	Y	Cb	Cr

3. Plug the connected devices into a mains socket.
4. Press the STANDBY button on the TV or the button on the remote control to turn on your TV.
5. Press the SOURCE button on the TV or remote control to display the source list. Use the buttons to select YPbPr and then press the OK button to confirm.

## Connecting an AV device with a SCART cable

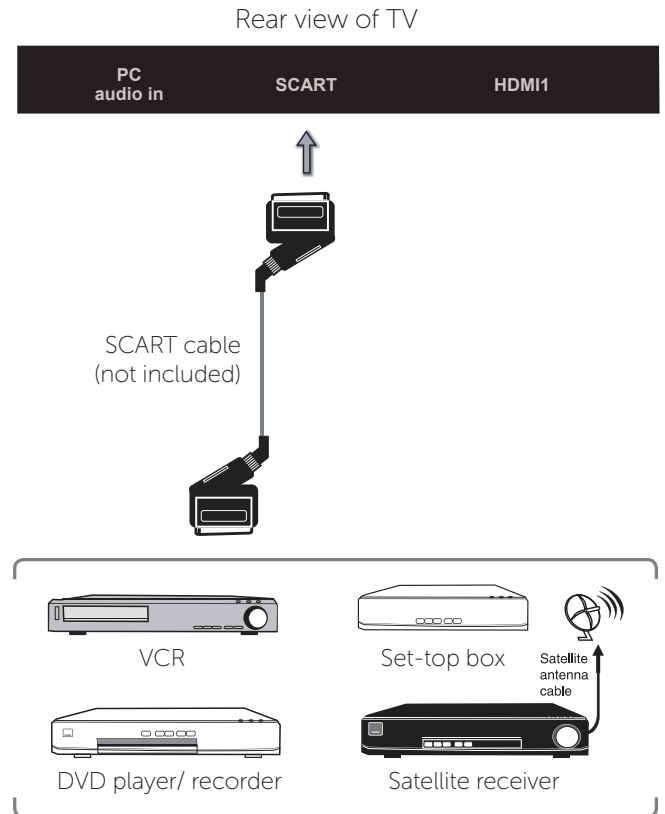

1. Use a SCART cable to connect the TV's SCART input socket to an external AV device's SCART output socket.
2. Plug the connected devices into a mains socket.
3. Press the STANDBY button on the TV or the button on the remote control to turn on your TV.
4. Press the SOURCE button on the TV or remote control to display the source list. Use the buttons to select SCART and then press the OK button to confirm.

If you require any technical guidance or find that your TV is not operating as intended, a simple solution can often be found in the **Troubleshooting** section of these instructions.

# Connections

Bringing it all together

## Connecting an AV device with a composite cable

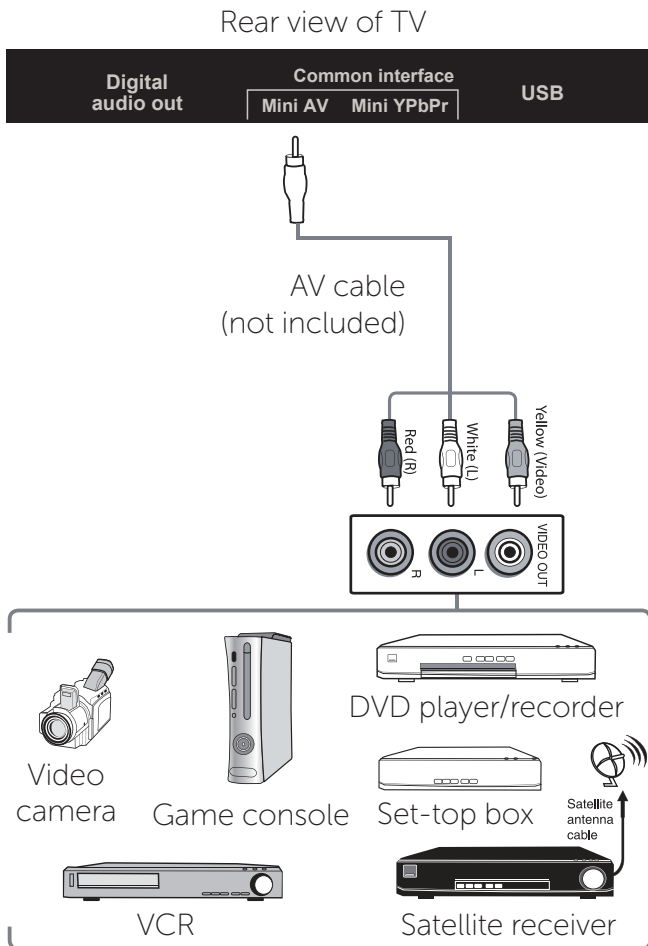

1. Use an AV cable to connect the TV's MINI AV input sockets to an external AV device's composite audio/video sockets. (Video = Yellow, Audio Left = White and Audio right = red).
2. Plug the connected devices into a mains socket.
3. Press the STANDBY button on the TV or the button on the remote control to turn on your TV.
4. Press the SOURCE button on the TV or remote control to display the source list. Use the buttons to select AV and then press the OK button to confirm.

## Connecting a digital audio receiver

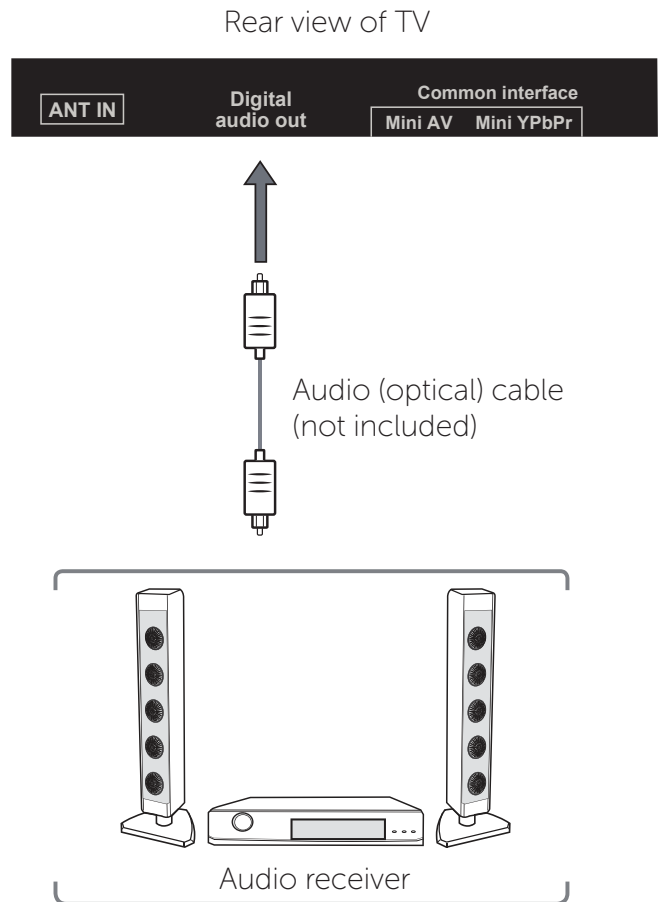

For better sound quality, you may want to play the audio through a multi-channel audio receiver.

1. Use an audio cable to connect the TV's digital audio output socket to an external audio receiver's audio optical input socket.
2. Plug the connected devices into a mains socket.
3. Press the STANDBY button on the TV or the button on the remote control to turn on your TV.
4. Press the SOURCE button on the TV or remote control to display the source list. Use the buttons to select any desired input source and then press the OK button to confirm.



- The TV's volume control will have no effect. You may control the audio level via the audio receiver.

# Connections

Bringing it all together

## Connecting headphones

Rear view of TV

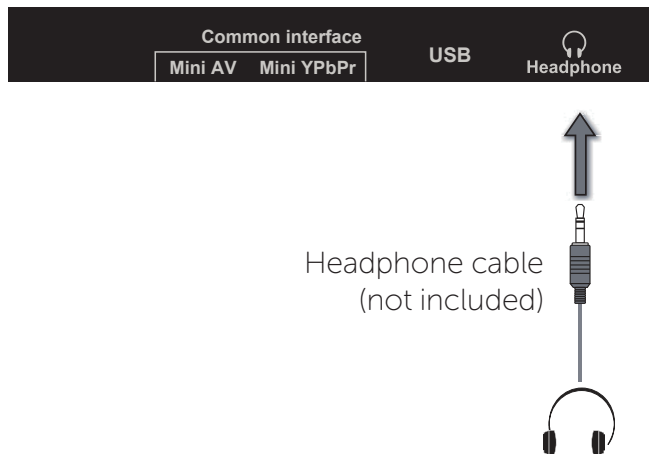

Connect your headphones to the TV's headphone output socket.

Before putting the headphones on turn the volume down. Put the headphones on and slowly increase the volume until you reach a comfortable listening level.



- Listen at moderate volumes to avoid hearing damage.
- If you hear no sound during playing, do not turn up volume up as the music may suddenly begin at a high volume.
- Excessive sound pressure from earphones and headphones can cause hearing loss.
- To avoid damaging your ears, adjust the volume to the lowest safe level before playing, and turn up to the desired level when playback has started.

If you require any technical guidance or find that your TV is not operating as intended, a simple solution can often be found in the **Troubleshooting** section of these instructions,



# Standard features 4

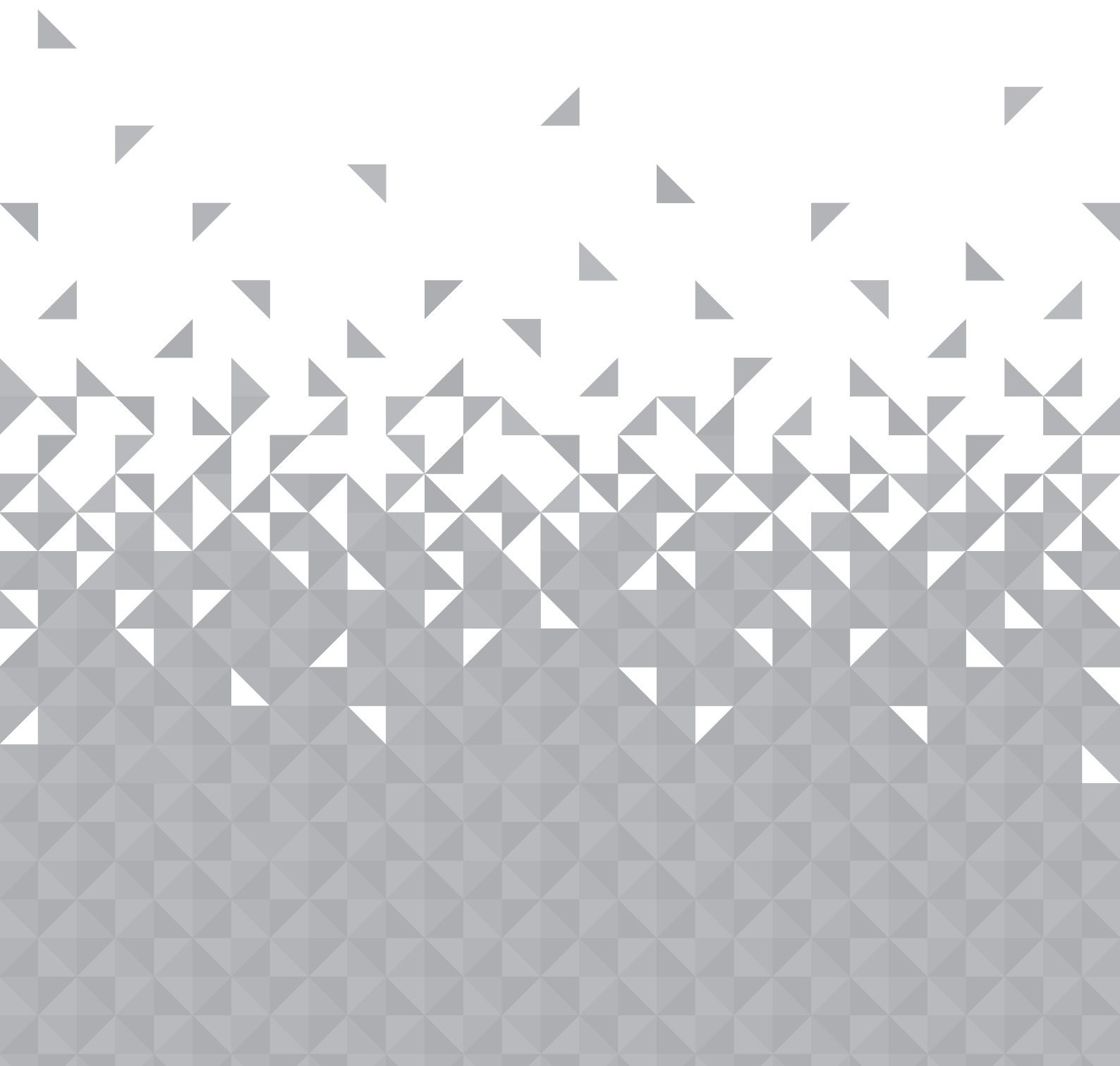

# Standard features

Simple everyday use

## Turning the TV on for the first time

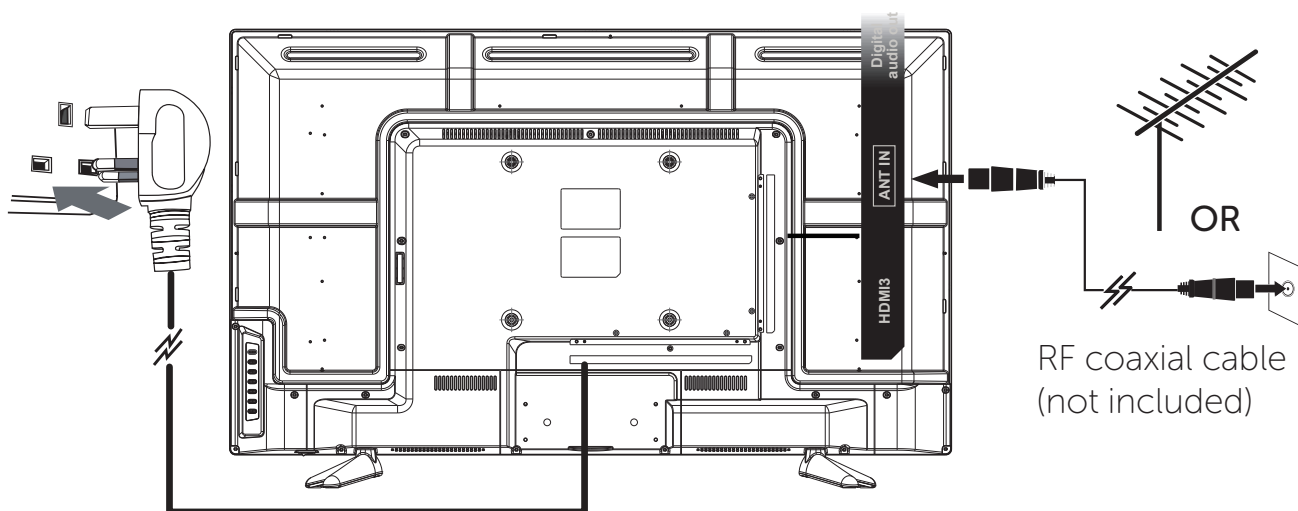

1. Connect one end of the RF coaxial cable to the aerial socket on the wall and the other end of the cable to the aerial socket at the rear side of the TV.



- DO NOT connect the TV to the mains supply until you have completed all the connections.

2. Connect the mains cable to a mains socket (after completing all other connections).
3. At this stage the TV will power on in standby mode (red LED indicator on the front panel). Press the STANDBY button on the TV or the  button on the remote control to turn on your TV (the red LED will change to green).







- The STANDBY button is located on the rear right hand side of the TV.



- Always disconnect the TV from the mains socket when not in use for a long period of time.

- The STANDBY button on the rear right hand side of the TV or the  button on the remote control is only used for switching the TV into standby. It does not disconnect the TV from the mains power. To completely disconnect the mains power, please remove the mains cable from the mains socket.

4. If this is the first time you are turning on the TV and there are no programs in the TV memory, the First Time Installation menu will appear on the screen.

Use the     navigation buttons to enter the settings, select the 'auto tuning' option and press the OK button to begin the setup process.

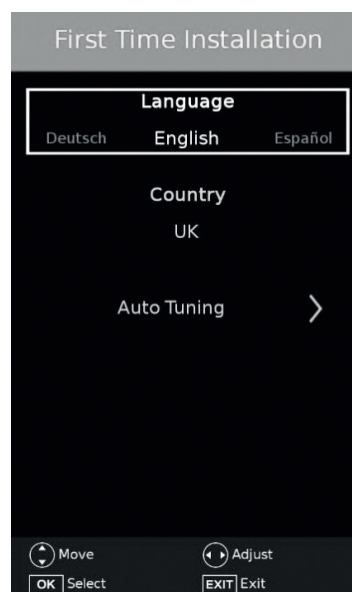

If you require any technical guidance or find that your TV is not operating as intended, a simple solution can often be found in the **Troubleshooting** section of these instructions,

# Standard features

Simple everyday use

## Selecting the input source



1. Press the SOURCE button on the TV or the remote control to display the input source list.
2. Press the ▲▼ buttons to select the input source you require: DTV, ATV, COMPOSITE-AV, SCART, PC-VGA, YPBPR, HDMI1, HDMI2 or HDMI3.
3. Press the OK button to confirm your selection.



- In DTV mode, press the RADIO button to switch to TV/Digital radio channels directly.

## Channel selection

- Press the CH+/- buttons on the TV or remote control repeatedly; or use the 0-9 buttons on the remote control to select a channel.



### Alternative:

Press the OK button to enter the channel list. Then use the ◀▶▲▼ buttons to highlight and select the channel.

Press the OK button to view the selected channel.

- A blocked channel will display 'CH BLOCKED' on-screen. Press the 'INFO' button to enter the passcode. (refer to page 31 for details on LOCK).
- Press the ↺ button to return to the previously viewed channel.

## Display channel information

- Press the ⓘ INFO button to view the current information.

## Volume adjustment

- Press the VOL+/- buttons on the TV or remote control to adjust the volume.
- If you wish to switch the sound off, press the MUTE button on the remote control. Press the MUTE button once more or the VOL+/- buttons to resume the audio.

## Using the Electronic Program Guide

Open the guide by pressing the EPG button on the remote.



The program guide displays a list of 8 channels along with the program schedule for the next 8 programmes.

The current channel marker is highlighted with a green block. The selected day/ date is listed along the top left.

- Use the ◀▶▲▼ navigation buttons to highlight any current or future programs.
- Pressing the ▼ button repeatedly so that the highlight marker proceeds past the displayed 8 programmes will load the next set of programs.

Along the bottom left of the guide is a key showing the usage of the colour buttons found on the remote control.

# Standard features

Simple everyday use

## PVR recording

NOTE: This function is only available with a compatible USB device connected.

Before you can record anything you will need to connect a USB device with space free for recordings.

If the device is not readable, slow or needs erasing see PVR file system on page 37.

### Recording a current show

1. Connect a USB device to one of the USB ports on the side of the TV.
2. To record a TV show currently airing press the REC button on the remote control to display the record menu and begin recording the current channel.



3. To stop the recording at any time press the 'REC' button once more to display the interface and select the STOP button using the ◀▶ buttons. You will be asked if you wish to stop the PVR?; press the ◀ button to select YES. The recording will then stop.

### Recording a future show

1. Connect a USB device to one of the USB ports on the side of the TV.
2. Press the EPG button on the remote to display the programme guide.
3. Use the ◀▶▲▼ buttons to locate a programme you wish to record.
4. Press the RED button on the remote to display the recording options.
5. Use the ◀▶▲▼ buttons to make adjustments.

Generally you really only need to adjust the recording frequency from Once, Daily or Weekly.

6. Press the OK button on the remote to schedule the recording.

### PVR schedule list

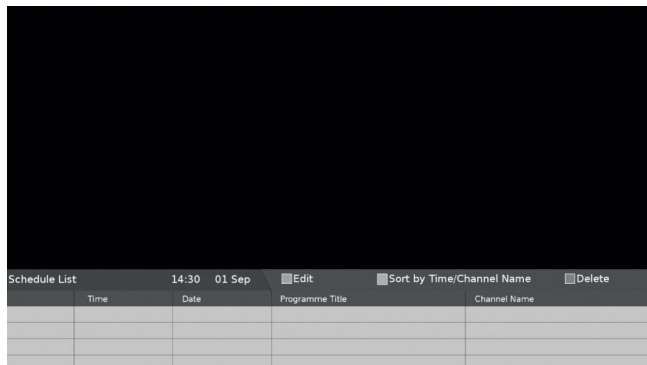

1. Press the EVENT LIST button on the remote control to display your scheduled recordings.
2. Select and press the GREEN button to edit the record settings.
3. Select and press the RED button to delete a scheduled recording.

If you require any technical guidance or find that your TV is not operating as intended, a simple solution can often be found in the **Troubleshooting** section of these instructions,

# Standard features

Simple everyday use

## Picture settings

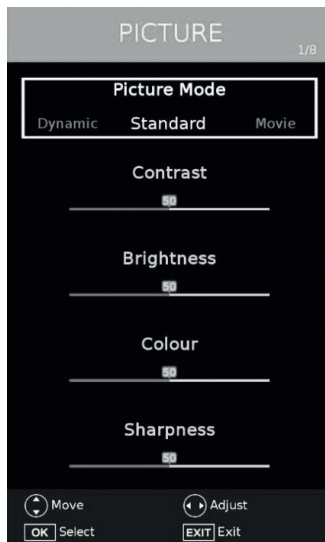

Adjust to set your preferred picture mode.

1. Press the MENU button, then use the ◀▶ buttons to select the PICTURE menu.
2. Press the OK button, then use the ▲▼ buttons to select the following picture options. Press OK to confirm.
3. Press the MENU button to return to a previous menu.

### Picture mode

Press the ◀▶ buttons to cycle through the picture modes: Dynamic, Standard, Movie, Game, PC, Cinema 24p & Personal. Press the OK button to confirm.



#### Alternative:

Press the PICTURE button once and then use the ◀▶ buttons to select the picture mode directly.

### Contrast

Use the ◀▶ buttons to adjust the difference between light and dark levels in the picture.

### Brightness

Use the ◀▶ buttons to increase or decrease the amount of white in the picture (user mode only).

### Colour

Use the ◀▶ buttons to increase or decrease the colour saturation.

### Sharpness

Use the ◀▶ buttons to adjust the level of crispness in the edges between light and dark areas of the picture (User mode only).

### Colour temperature

Use the ◀▶ buttons to cycle through the colour temperature options: Normal, Cold or Warm. Press the OK button to confirm.

### Aspect ratio

Use the ◀▶ buttons to cycle through the aspect ratio settings: 4:3, 16:9, Auto, Zoom 1 and Zoom 2. Press the OK button to confirm.



#### Alternative:

Press the PICTURE button twice and then use the ◀▶ buttons to select the aspect ratio directly.

### Expert Settings>

#### Noise reduction

Use the ◀▶ buttons to adjust the picture noise reduction level from: Off, Low Middle and High. Press the MENU button to confirm.

# Standard features

Simple everyday use

## Aspect ratio's explained

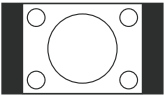
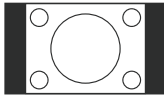
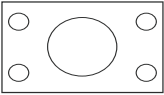
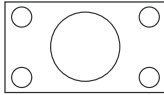
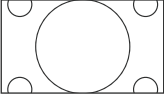
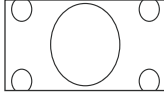
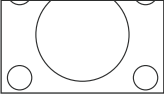
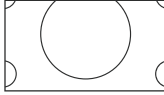
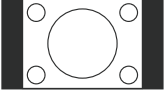
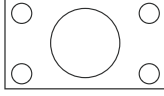
	Input signal 4:3		Input signal 16:9	
<b>4:3</b>	This selection will allow you to view a picture with an original 4:3 aspect ratio. Black bars will appear on both the left and right of the screen.		This selection will allow you to adjust the picture horizontally in linear proportion. Black bars will appear on both the left and right of the screen.	
<b>16:9</b>	This selection will allow you to adjust the picture horizontally in linear proportion to fill the entire screen.		This selection will allow you to view the picture with an original 16:9 aspect ratio.	
<b>Zoom 1</b>	This selection will allow you to zoom into the picture without any alteration, while filling the entire screen. However the top and bottom of the picture will be cropped.		This selection will allow you to zoom into the picture without any alteration. While the 4 sides of the picture will be cropped.	
<b>Zoom 2</b>	This selection is similar to 16:9 mode, but the picture slightly stretches vertically and crops a little from the top and bottom.		This selection is similar to 16:9 mode, but the picture slightly stretches vertically and crops a little from the top and bottom.	
<b>Just scan (HDMI mode only)</b>	This selection will detect the resolution of the HDMI signal and display the image with the same number of pixels.		This selection will detect the resolution of the HDMI signal and display the image with the same number of pixels.	

If you require any technical guidance or find that your TV is not operating as intended, a simple solution can often be found in the **Troubleshooting** section of these instructions,

# Standard features

Simple everyday use

## Sound settings

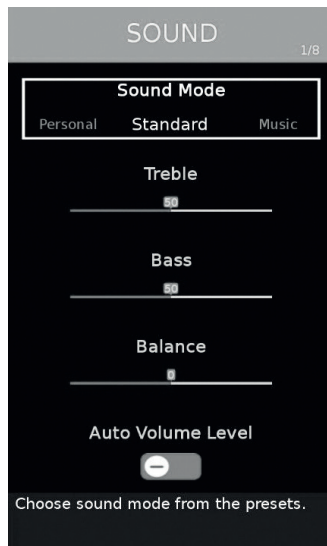

Adjust to your preferred audio enhancement.

1. Press the MENU button, then use the ◀▶ buttons to select the SOUND menu.
2. Press the OK button, then use the ▲▼ buttons to select the following sound options. Press OK to confirm.
3. Press the MENU button to return to a previous menu.

### Sound mode

Press the ◀▶ buttons to cycle through the audio enhancement modes: Standard, Music, Movie, News and Personal. Press the OK button to confirm.



#### Alternative:

Press the SOUND button once and then use the ◀▶ buttons to select the sound mode directly.

### Treble

Use the ◀▶ buttons to increase or decrease the treble level (user mode only)

### Bass

Use the ◀▶ buttons to increase or decrease the bass level (user mode only)

### Balance

Use the ◀▶ buttons to adjust the relative volume of the speakers in a multi speaker system.

### Auto volume level

This feature automatically adjusts the audio level when the TV is turned ON. The function is activated by selecting ON.

### Digital output mode

Select the digital mode when using a DIGITAL OPTICAL cable to a digital audio receiver. Select from PCM, AUTO and OFF.

### Audio description

Enable the audio description function by selecting ON.

### AD volume

Adjust the volume level of the audio description function.

### Audio language

Select your preferred language.

# Standard features

Simple everyday use

## Channel settings

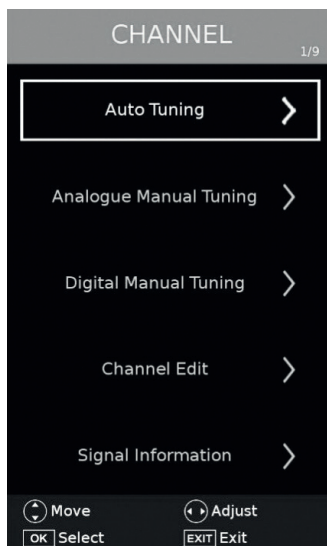

Allows you to set up a variety of channel options.

1. Press the MENU button and then use the ◀▶ buttons to select the CHANNEL menu.
2. Press the OK button and use the ▲▼ buttons to select any of the following channel options. Press OK to confirm.

## Auto tuning

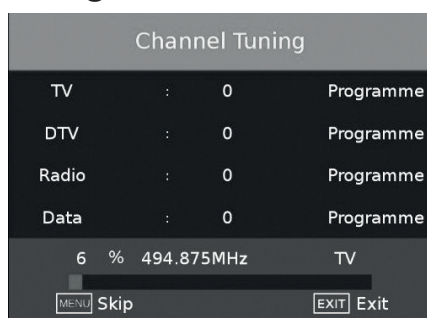

1. Use the ▲▼ buttons to select AUTO TUNING then press the OK button to confirm.
2. Use the the ▲▼◀▶ buttons to choose a tuning mode and country. Then select 'Auto tuning' and press the OK button to begin tuning.
3. Press the MENU button to return back to the main menu

## Analogue manual tuning

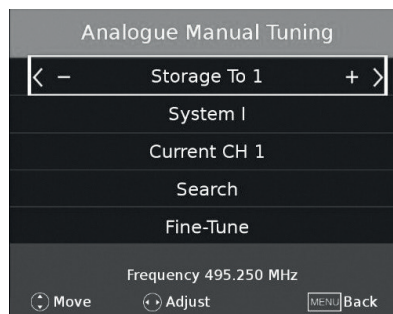

Search analogue channels by entering parameters manually.

1. Use the ▲▼ buttons to select ANALOGUE MANUAL TUNING then press the OK button to confirm.

2. The options are as follows:

Storage to 1	Use the ◀▶ buttons to change the numbered location of the found channel.
Sound system	Select the sound system BG / DK / I / L / L'.
Current channel	Displays the current channel number.
Search	Use the ◀▶ buttons to start the manual tuning.
Fine-tune	Use the ◀▶ buttons to make fine manual adjustments to the tuning.

3. Press the MENU button to return to a previous menu.

If you require any technical guidance or find that your TV is not operating as intended, a simple solution can often be found in the **Troubleshooting** section of these instructions,



# Standard features

## Simple everyday use

### DVB-T manual tuning

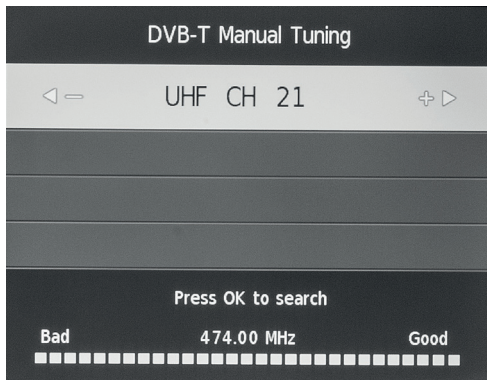

How to search digital channels manually.

1. Use the ▲▼ buttons to select DVB-T MANUAL TUNING then press the OK button to confirm.
2. Select a channel number by pressing the ► button or by using the number buttons on the remote control. The strength and quality of the signal indication bars are below.
3. Select OK to begin the search.
4. To exit, press the MENU button.

### Channel edit

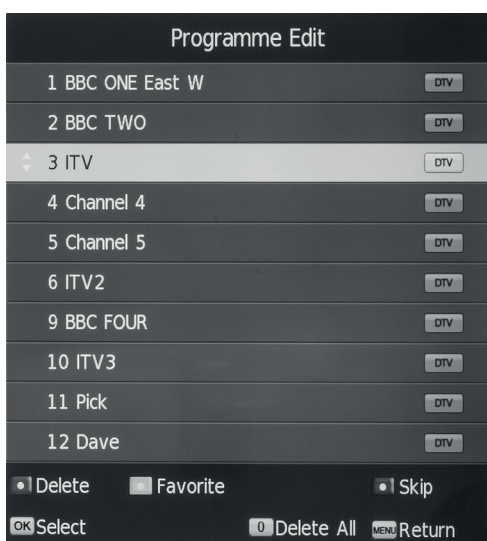

- Use the ▲▼ buttons to select CHANNEL EDIT. Press the OK or ► button to enter the menu. Use the ▲▼ buttons to navigate through the menu.

### Delete

- Press the RED button to delete the highlighted channel.

---

To restore the deleted channels, run an auto scan.

---

- Press the MENU button to return to the main menu.

### Move

- Use the ▲▼ buttons to select the channel; press the YELLOW button to enter move mode (the channel is highlighted in red). Use the ▲▼ buttons to move the channel location. Press the YELLOW button once more to confirm.
- Press the MENU button to return to the main menu.

### Skip

- Use the ▲▼ buttons to select the channel; press the BLUE button to assign the skip function. Press once more to remove the skip function.

### Skip

- Use the ▲▼ buttons to select the channel you wish to skip.
- Press the BLUE button; a logo will appear next to the channel name and the channel will be skipped when you scroll through the channels.
- Press the BLUE button once more on the highlighted channel to disable the skip function.
- Press the MENU button to return to the main menu.

### Signal information

Only available in DTV mode. Signal information includes: Channel, network Modulation, Quality and Strength info.

### CI information

When a CI module is inserted this function displays the relevant information.

# Standard features

Simple everyday use

## Recorded list

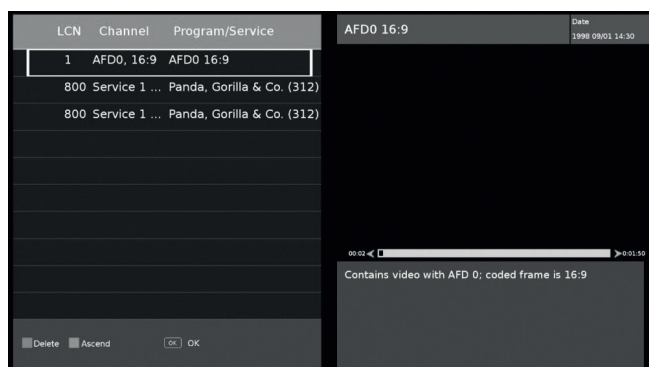

NOTE: This function is only available with a compatible USB device connected.

- Use the ▲▼ buttons to select RECORDED LIST. Press the OK or ► button to enter the interface. Use the ▲▼ buttons to navigate through the recordings.
- Press the RED button to delete a recording.

## Schedule list

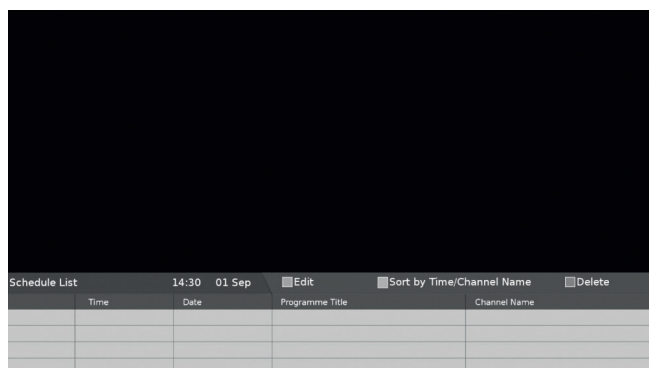

NOTE: This function is only available with a compatible USB device connected.

- Use the ▲▼ buttons to select SCHEDULE LIST. Press the OK or ► button to enter the interface. Use the ▲▼ buttons to navigate.
- Press the GREEN button to edit a recording schedule.
- Press the RED button to delete a scheduled recording.

## Lock settings

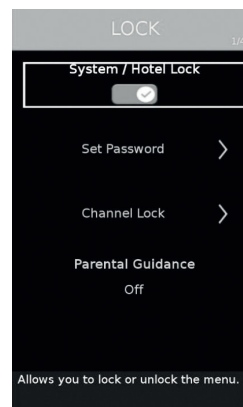

1. Press the MENU button and then use the ◀▶ buttons to select the LOCK menu.
2. Press the OK button and then use the ▲▼ buttons to select any of the following features.

## Lock system

1. Use the ▲▼ buttons to select LOCK SYSTEM and press the OK button to confirm.

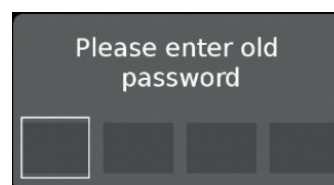

2. Use the 0-9 buttons to input a 4 digit password to enter the lock menu, then press the OK button to enable to lock system.
- The default password is '0000'.
  - If you change the password, be sure to make a note of the new password. If you forget the new password, use the master password '4711'.

**Set Password:** Change the password.

# Standard features

## Simple everyday use

**Channel lock:** This feature is available only for digital TV and the tuned-in channel must support it.



Use the ▲▼ buttons to select a channel you wish to block and press the GREEN button to lock. Press again to unlock.

### Parental guidance:

**Off:** Turn off parental lock

**4-18:** Turn on parental lock and set the age level required.

## Time settings

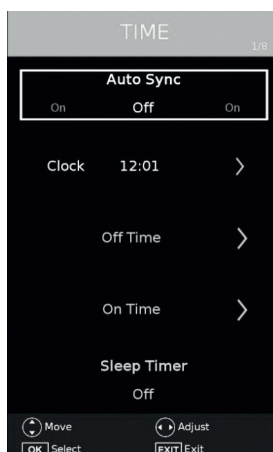

1. Press the MENU button and then use the ◀▶ buttons to select the TIME menu.
2. Press the OK button and use the ▲▼ buttons to select from the following options. Press the OK button to adjust.

## Auto sync

When enabled the time and date will be set automatically from a digital signal.

## Clock

Press the OK button to set the date and time.

## Off time

Press the OK button to set the OFF time.

## On time

Press the OK button to set the ON time.

## Sleep timer

The sleep timer automatically switches the TV to standby mode after the pre-set time has elapsed. The clock will be set automatically when receiving a digital signal. Time must be set before using the sleep timer function.

- Use the ▲▼ buttons to select a period of time after which the TV automatically switches to standby mode: Off, 10, 20.., 180 and 240 mins. Press the OK button to confirm the selection. The timer begins to count down from the number of minutes selected.

## OSD timer

- Use the ▲▼ buttons to select the display time of the on-screen menu: 5s, 15s, 30s, 60s or never. (OFF) Press the OK button to confirm.

## Auto standby

The unit will automatically switch to standby mode 4 hours after the last time the remote control was used by default. A reminder screen will pop-up and count down before the unit switches to standby mode.

Select from 3h, 4h 5h or OFF (If you wish to operate the TV for a long period of time, turn off the auto standby function by selecting OFF).

# Standard features

Simple everyday use

## Time zone

When you select a time zone city, the TV time is set by the time offset information based on times zones and GMT, which is received with the broadcast signal.

- Use the ◀▶ buttons to select the required time zone city and then press the OK button to confirm (DTV only).

## Network settings



1. Press the MENU button and then use the ◀▶ buttons to select the NETWORK menu.
2. Press the OK button and use the ▲▼ buttons to select from the following options. Press the OK button to adjust.

## IP configuration



NOTE: Connect the TV with an ethernet cable to your network to gain access to the internet.

1. Use the ◀▶ buttons to select AUTO to automatically setup the internet connection.
2. To set manually choose MANUAL. Then use the ▲▼ buttons and numeric buttons to enter the IP address, Net mask, Gateway & DNS settings.

## Network info

Select this option to display information about the network connection.

## Network test

Run this function to test the network.

# Standard features

Simple everyday use

## Setup settings

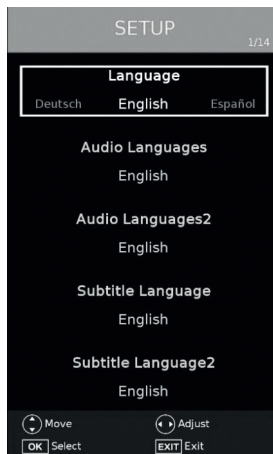

1. Press the MENU button and then use the ◀▶ buttons to select the SETUP menu.
2. Press the OK button and use the ▲▼ buttons to select from the following options. Press the OK button to adjust.

### Language

Allows you to select the on-screen display menu language.

### Audio languages(2)

Select the first and second choice audio languages. The availability of this function depends on the tuned-in channel (can only be selected in DTV mode).

### Subtitle language(2)

Select the first and second choice subtitle language. The availability of this function depends on the tuned-in channel (can only be selected in DTV mode).

### Hearing impaired

Allows you to show more information in subtitles for the hearing-impaired in some programmes (can only be selected in DTV mode).

### Blue screen

Enables a blue background when no input is detected.

### PVR file system

**Select Disk:** Select which of the 2 USB inputs is to be used for the PVR record function.

**Timeshift size:** Select the file size chunks the PVR will record to.

**Format:** Select to format the attached USB storage device.

---

WARNING: This will erase all data on the device.

---

**Speed:** Select to perform a speed test on the attached USB storage to detect if it is fast enough to write the recording data.

### First time installation

This option allows you to reset the TV to the default factory setting. Once activated the TV will go into standby mode.

### Software update (USB)

Run this operation with a software update on an attached USB device.

### Software update (NET)

Run this operation when connected to the internet to check for software updates on-line.

### Version info

Displays the current software version.

# Standard features

Simple everyday use

## PC settings

When a PC is connected to the TV via the VGA socket a PC setting mode will become available in the menu options.

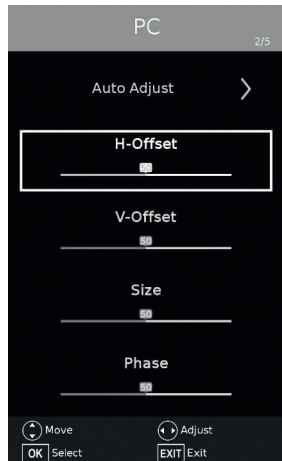

1. Press the MENU button and then use the ◀▶ buttons to select the PC menu.
2. Press the OK button and use the ▲▼ buttons to select from the following options. Press the OK button to adjust.

### Auto adjust

Adjusts the Phase, H-position, size & V-position settings automatically.

### Horizontal pos.

Shift the screen up or down.

### Vertical pos.

Shift the screen left or right.

### Size

Adjust the size of the picture.

### Phase

Adjust the internal signal phase.

If you require any technical guidance or find that your TV is not operating as intended, a simple solution can often be found in the **Troubleshooting** section of these instructions,

# Advanced features

5

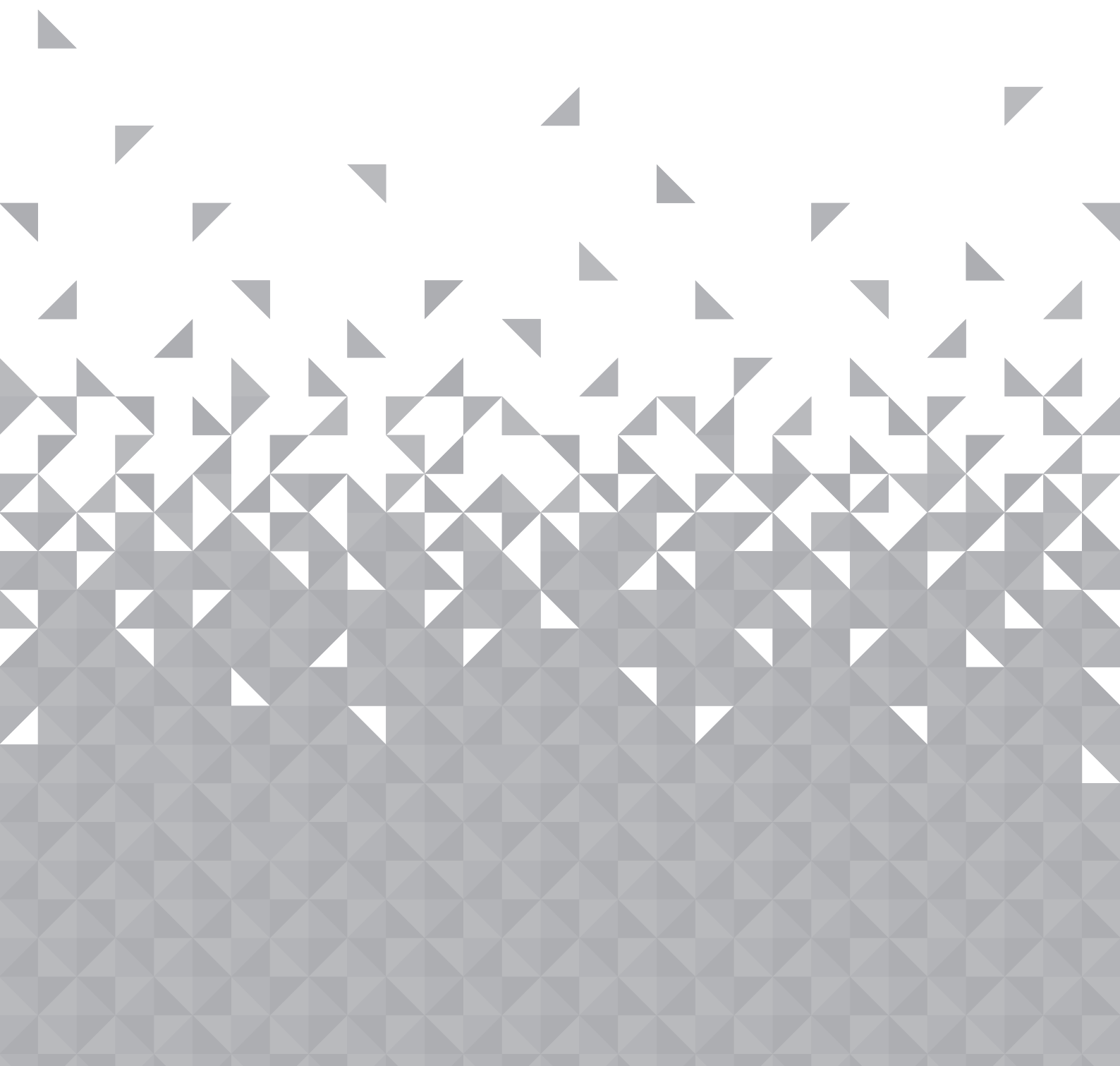

# Advanced features

Getting the most from your TV

## Connecting a USB storage device

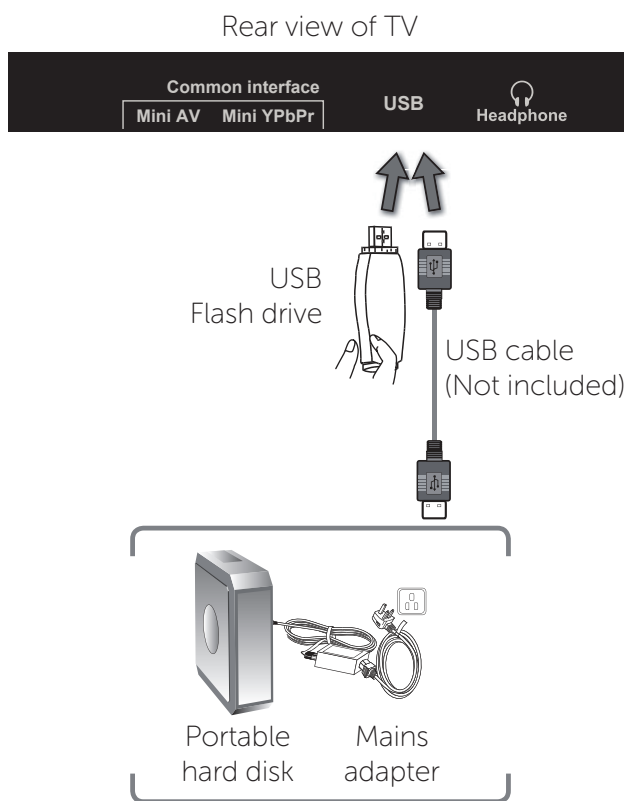

- If a hard disc is used, make sure it's mains adapter is connected to the mains supply.
- If a USB hub is used, make sure it's mains adapter is connected to the mains supply as the total current consumption may exceed 500mA.
- The maximum supported storage space of the hard disk is 1TB.
- Supported file systems: FAT 16, FAT32 and NTFS (compressed files not supported).
- In order to store recordings of a DTV programme the transfer rate of the USB device must be 5MB/s or higher. If not the picture and sound will be affected. A warning statement will be displayed on-screen.
- The TV screen will be black initially while the hard disk is connected. This is normal and the starting time may vary depending on the connected device and storage size of the connected device.
- Disconnect the USB device if not in use.
- USB output: DC 5V  $\overline{\text{---}}$  500mA.

1. Switch OFF the TV before connecting an USB storage device.
2. Connect your USB storage device to one of the USB ports on the side of the TV.
3. Plug the connected devices into the mains socket (if required)
4. Press the STANDBY button on the TV or the  button on the remote control to turn on your TV.

If you require any technical guidance or find that your TV is not operating as intended, a simple solution can often be found in the **Troubleshooting** section of these instructions,



# Advanced features

Getting the most from your TV

## Multimedia interface

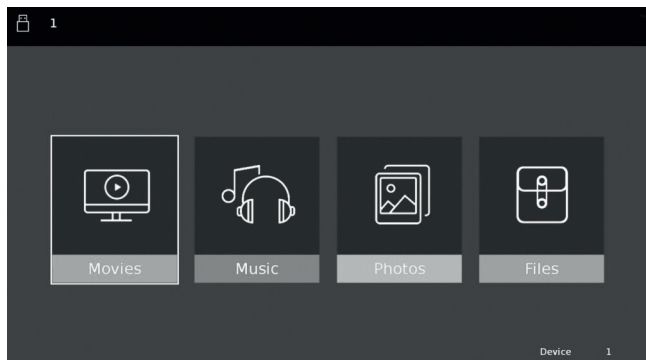













1. Press the USB button on the remote control or press the MENU button and select USB MEDIA to display the multimedia interface.
2. Use the ◀▶ buttons to select the type of file you wish to view.

## Movie operation



Use the ◀▶ buttons to select an option and press the OK button to activate.

See a list of supported media formats on page 43.

 Previous	Press to play the previous movie.
 Next	Press to play the next movie.
 Pause	Press to pause the movie.
 Stop	Press to play or stop.
 FB	Press to rewind.
 FF	Press to fast forward.
 Repeat	Press to play all movies in the current folder repeatedly. Press OK to select the repeat mode from Repeat 1, ALL & NONE.
 TimePlay	Select to set the play time.
 Enlarge	Press to enlarge the picture.
 Shrink	Press to shrink the picture.
 Playlist	View the play list.
 Info	View the movie information.

# Advanced features













Getting the most from your TV

## Photo operation



Use the ◀▶ buttons to select an option and press the OK button to activate.

See a list of supported media formats on page 43.

	Press to play the previous photo.
	Press to play the next photo.
	Press to pause the photo.
	Press to play or stop.
	Press to rotate 90° clockwise
	Press to rotate 90° anti-clockwise
	Press to enlarge the photo.
	Press to shrink the photo.
	Press to move the photo.
	Press to play all the photos in the current folder repeatedly.
	View the play list.
	View the photo information.

## Music operation

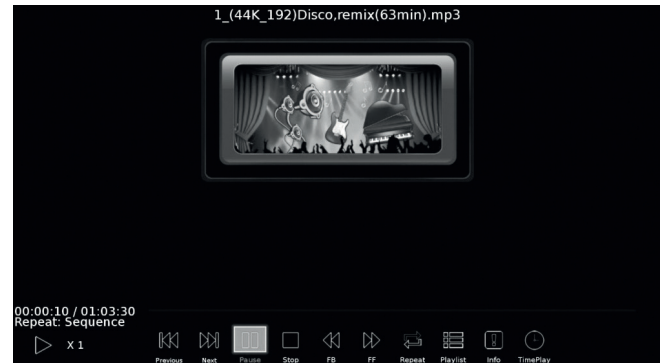

Use the ◀▶ buttons to select an option and press the OK button to activate.

See a list of supported media formats on page 43.

	Press to play the previous track.
	Press to play the next track.
	Press to pause the current track.
	Press to play or stop.
	Press to rewind.
	Press to fast forward.
	Press to play all tracks in the current folder repeatedly. Press OK to select the repeat mode from Repeat 1, ALL & NONE.
	View the play list.
	View the photo information.
	Select to set the play time.

If you require any technical guidance or find that your TV is not operating as intended, a simple solution can often be found in the **Troubleshooting** section of these instructions.

# Advanced features

Getting the most from your TV

## Supported multimedia formats

Media	File extension	Codec		Remark
		Video	Audio	
Movie	.mpg	MPEG-1, MPEG-2	MP3, AAC, AC3, PCM	Max resolution 1920 x 1080 Max data rate: 40mbps
	.avi	Xvid, MJPEG		Max resolution 1920 x 1080
		MPEG-4 SP/ASP, H.263/H.264		Max data rate: 20mbps
	.ts	MPEG-2, H.264, AVS*, AVS+*, HEVC		
	.mov .mkv	MPEG-4 SP/ASP, H.263/H.264, HEVC		
	.dat	MPEG-1		
	.mp4	MPEG-4 SP/ASP, H.263/H.264, HEVC		
		MPEG-1, MPEG-2		Max resolution 720 x 576
.vob	MPEG-2	Max data rate: 40mbps		
Music	.mp3	-	MP3	Sample rate: 8K-48KHz Bit rate: 32K-320Kbps Channel: Mono/ Stereo
	.m4a/ .aac	-	AAC	Sample rate: 16K-48KHz Bit rate: 32K-442Kbps Channel: Mono/ Stereo
Photo	.jpg	Progressive JPEG		Max resolution 1024 x 768
	.jpeg	Baseline JPEG		Max resolution 15360 x 8640
	.bmp	BMP		Max resolution 9600 x 6400 Pixel depth: 1/4/8/16/24/32 bit
	.png	Non-interlaced		Max resolution 9600 x 6400
Interlaced		Max resolution 1280 x 800		

This page is left intentionally blank

# Other information

6

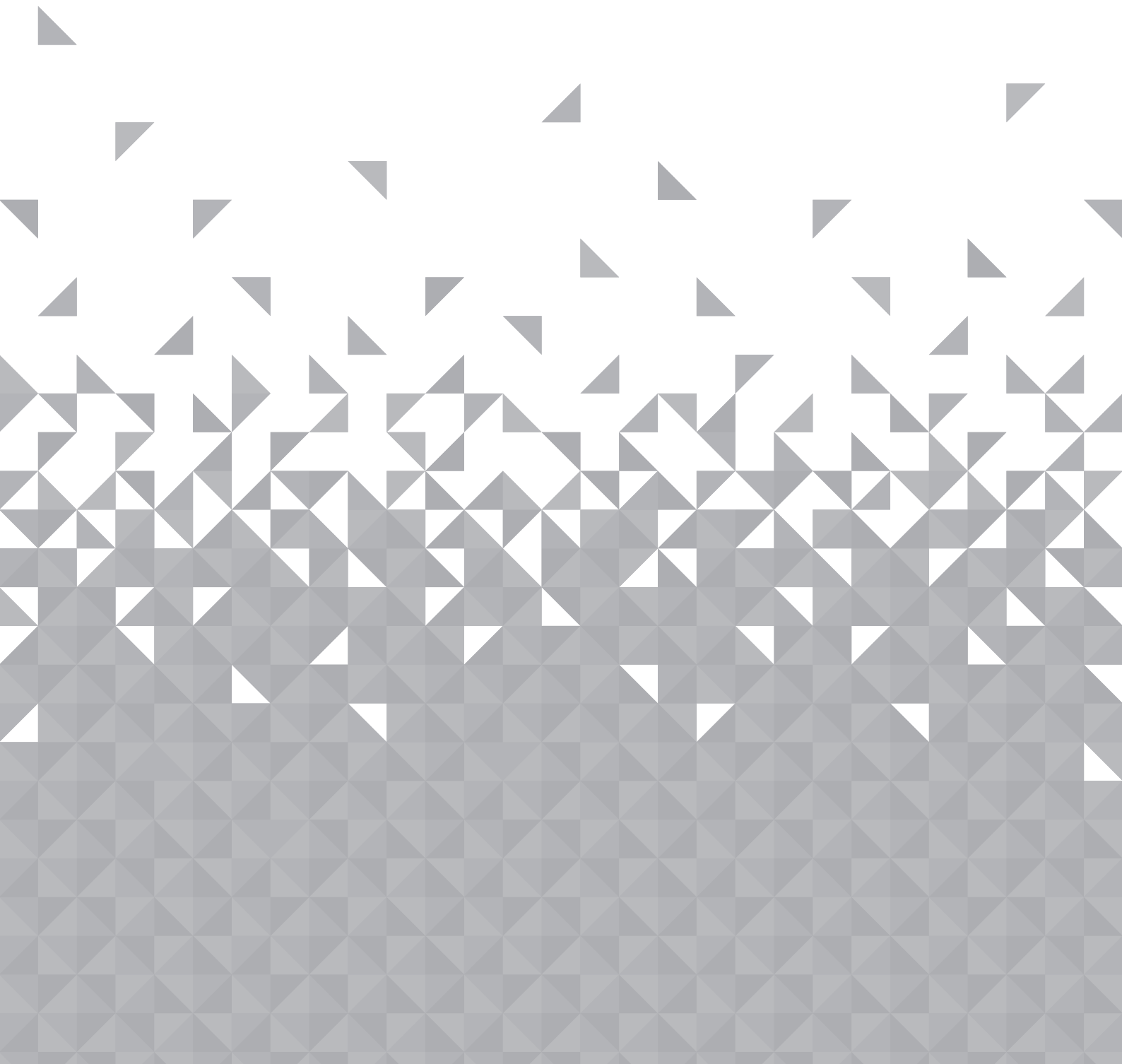

## Other information

Helpful technical information

## Technical specification

### TV

Panel system	40" LED panel
Display resolutions	1920 (H) x 1080 (V) pixels
Television system	PAL / BG / DK / SECAM
Brightness	220 cd/m <sup>2</sup>
Contrast ratio	4000:1
Power source	AC 100-240V ~ 50/60Hz
Energy efficiency class	A+
Screen size (measured diagonally)	Approx 101cm (40")
Power consumption	62W
Operating temperature	0°C - 40°C
Vesa wall mount size/screw size	200 x 200mm /M5 x 10
Speaker power	10W x 2
Dimensions without base	914 (W) x 91 (D) x 539 (H) mm
Dimensions with base	914 (W) x 257 (D) x 581 (H) mm
Weight (net)	7.05KG

## Display modes

The screen resolution has been optimised during production for the display modes listed below.

### YPbPr mode

Resolution	Vertical frequency (Hz)	Aspect ratio
480i: 720 x 480	60	4:3, 16:9, Zoom1, Zoom2
480p: 720 x 480		
576i: 720 x 576	50	
576p: 720 x 576		
720p: 1280 x 720	50	
	60	
1080i: 1920 x 1080	50	
	60	
1080p: 1920 x 1080	50	
	60	

If you require any technical guidance or find that your product is not operating as intended, a simple solution can often be found in the **Troubleshooting** section of these instructions.

# Other information

## Helpful technical information

### PC mode

Please check the display settings of your computer before connecting to the TV. If the display setting of your computer does not match the TV, there may be no video.

Resolution	Vertical frequency (Hz)	Aspect ratio
640 x 480	60	4:3, 16:9
	72	
800 x 600	60	
	72	
	75	
1024 x 768	60	
	72	
	75	
1360 x 768	60	
1920 x 1080	60	

### HDMI mode

Resolution	Vertical frequency (Hz)	Aspect ratio
480i: 720 x 480	60	4:3, 16:9, Zoom1, Zoom2, Just scan
480p: 720 x 480		
576i: 720 x 576	50	
576p: 720 x 576		
720p: 1280 x 720	50	
	60	
1080i: 1920 x 1080	50	
	60	
1080p: 1920 x 1080	50	
	60	

# Other information

## Helpful technical information

### Care & maintenance

#### After using the TV

Set to Standby.

Switch the unit off at the mains and unplug it if you are leaving it unattended for a long period (holidays etc).

Avoid leaving the batteries fitted in the remote control if you leave the unit unattended for long periods. They may leak and damage the remote control.

#### Care & cleaning

All care and cleaning operations should be carried out with the unit unplugged from the mains power.

Use a soft dry cloth to wipe away dust from the screen and surface.





If the surfaces are extremely dirty, clean the TV with a cloth which has been dipped in weak soapy water. Wring the cloth until it is almost dry, then use it to wipe the TV.

Ensure there is no excess water on the screen. Allow any water or dampness to evaporate before switching the TV on.



- NEVER use alcohol, benzene, paint-thinner, cleaning fluid or other chemicals. Do not use compressed air to remove dust.

### Disc handling

- Do not touch the playback side of the disc. 
- Do not attach paper or tape to disc. 
- Fingerprints and dust on the disc cause picture and sound deterioration. Wipe the disc from the centre outwards with a soft cloth. Always keep the disc clean. 
- If you cannot wipe off the dust with a soft cloth, wipe the disc lightly with a slightly moistened soft cloth and finish with a dry cloth. 
- Do not use any type of solvent such as thinner, benzene, commercially available cleaners or antistatic spray for vinyl. It may damage the disc.
- Do not store discs in a place subject to direct sunlight or near heat source.
- Do not store discs in a place subject to moisture and dust such as a bathroom or near a humidifier.
- Store discs vertically in a case, stacking or placing object on discs outside or their case may cause warping.



**Product support**

7

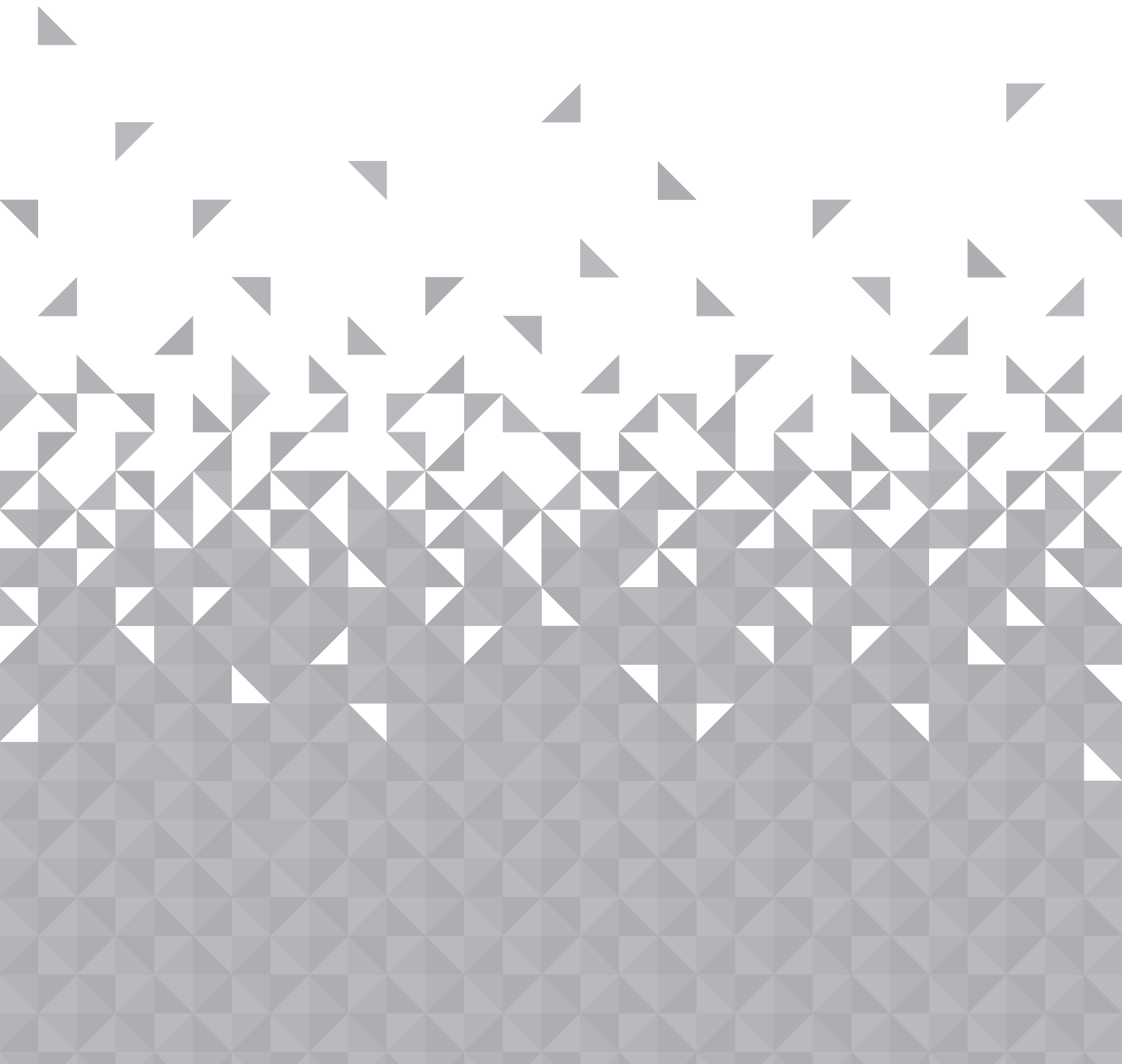

# Product support

Help is always at hand

## Troubleshooting

The TV does not respond when pressing any buttons.

- The TV may freeze up during use. Disconnect the mains cable from the mains socket for a few minutes. Reconnect the mains cable and try to operate as usual.

The TV cannot be switched on.

- Check the TV is connected to the mains supply.
- Make sure all connected AV devices are switched off before switching on your TV.

The remote control does not work.

- Check to see if there are any objects between the TV and the remote control causing an obstruction. Ensure that you are pointing the remote control directly at the TV.
- Ensure that the batteries are installed correctly with the polarity (+ to + and - to -).
- Install new batteries.

Power is suddenly turned off.

- Check the power of the TV. The mains supply may be interrupted.
- Check if the sleep timer is set.
- Check whether the auto standby has activated.

## Video problems

No picture or sound.

- Check whether the TV is switched on.
- Try another channel. The problem may be caused by the broadcaster.

Picture appears slowly after switching on.

- This is normal. The image is muted during the TV start-up process. Please contact your technical assistance if the picture has not appeared after 5 minutes.

None or poor colour/ Poor picture.

- Adjust the settings in the PICTURE menu.
- Try another channel. The problem may be caused by the broadcaster.

Horizontal / Vertical bar or picture shaking.

- Check for local interference such as an electrical appliance or power tool.

# Product support

Help is always at hand

## Poor reception on some channels.

- Station of cable channel may be experiencing problems, tune to another station.
- Station signal is weak, reposition the aerial for better reception.
- Check for sources of possible interference.

## Lines or streaks in pictures.

- Check aerial (change the position of the aerial).

## No picture when connecting with an HDMI cable.

- Check the input source is set to HDMI.

## Picture appears in wrong ratio.

- Adjust the ASPECT RATIO settings in the PICTURE menu.

## Audio problems

### Picture OK but no sound.

- Press the VOL +/- buttons.
- Sound may be muted. Press the MUTE button to check.
- Try another channel. The problem may be caused by the broadcaster.

### No output from one of the speakers.

- Adjust the BALANCE settings in the SOUND menu.

### Unusual sound from inside the TV.

- A change in ambient humidity or temperature may result in an unusual noise when the TV is switched on or off and does not indicate a fault with the TV.

### No sound when connecting HDMI.

- Check is the input source is HDMI.

### Audio noise.

- Keep the RF coaxial cable away from other connected cables.

# Product support

Help is always at hand

## PC mode problems

The signal is out of range (invalid format)

- Adjust the resolutions, horizontal frequency or vertical frequency.

Vertical bar or stripe on the background and horizontal noise/ incorrect position

- Use Auto Configure or adjust the clock, phase or H/V position.

Screen colour is unstable or single colour

- Check the signal cable.
- Re-install the PC video card.

## Frequently asked questions

Why have I lost some/ all of my channels?

- It happens sometimes If you have a weak signal. Usually it just means you'll need to re-scan your digital box or TV. Do not worry, it is easy to do. And once you've done it, you should get all the Freeview channels available to you. If the problem persists, you may need to get your aerial checked. Talk to technical support or contact your local aerial installer.

Why do I get 'blocking' on my digital picture?

- In most cases, blocking is caused by a reception problem - either the signal is too weak or there is some kind of interference. Talk to technical support or contact your local aerial installer.
- Blocking can also be caused by a digital signal that is too strong. If you are still experiencing blocking and the signal is strong, consult your local aerial installer for advice.

Can I watch Freeview using a portable set-top aerial?

- Some, but only a few, homes may be able to use a set top aerial. However, for a much better reception, we strongly recommend that you use a rooftop aerial.
- If you do not have access to a rooftop aerial - for example, if you live in a flat and the aerial is the responsibility of your landlord, or if you're using a second TV in the bedroom and don't want the hassle and expense of using extension cables, a set-top aerial may be your only option.

What type of aerial do I need?

- If you are installing a new aerial, we recommend a wideband rooftop aerial rather than a loft aerial. Loft aerials generally receive a weaker signal and are more likely to get interference from other electrical devices in the home. We suggest you have an aerial survey done before getting an aerial upgrade.
- Talk to your local aerial installer.

# Product support

Help is always at hand

## Help and assistance

If you require any technical guidance or find that your TV is not operating as intended, a simple solution can often be found in the **Troubleshooting** section of these instructions or online at [www.argos-support.co.uk](http://www.argos-support.co.uk)

If you still require further assistance, call one of our experts on **0345 604 0105\***. To help give us give you a fast and efficient service please have the following information ready:

Model Ref.	<input type="text" value="CTV401"/>	You can find these on the rating plate - a small information panel (usually a sticker or metal plate) on the rear of your product
Serial number	<input type="text"/>	
Date of purchase	<input type="text"/>	

Local call rates applies\*

Lines open 8am-7pm Monday to Saturday and 10am-4pm Sunday.

\*Calls to Argos enquiry lines may attract a charge and set up fee from residential lines depending on your call plan/tariff. Mobile and other providers costs may vary, see [www.bt.com/pricing](http://www.bt.com/pricing) for details.

For Security and training purposes, telephone calls to and from customer service centres maybe recorded and monitored. Calls from Republic of Ireland will attract international call charges.

or online at [www.argos-support.co.uk](http://www.argos-support.co.uk) If you still require further assistance, call one of our experts on **0345 604 0105**.

# Product support

Help is always at hand

## Disposal



- Disposal of your old product. Your product is designed and manufactured with high quality materials and components, which can be recycled and reused
- When this crossed out wheeled bin symbol is attached to a product it means the product is covered by the European Directive 2002/96/EC.
- Please make yourself aware of the local collection system for electrical and electronic products.
- Please act according to your local rules and do not dispose of your old products with your normal household waste.
- The correct disposal of your old product will help prevent potential negative consequences for the environment and human health.

**CE** This product is intended for use within the UK. This equipment complies with the essential requirements for the Radio Equipment and Telecommunications Terminal Equipment Directive 1999/5/EC.

This appliance complies with the following EEC directives: 2014/35/EU Low voltage directive / 2014/30/EU EMC directive

# Product support

Help is always at hand



## Call us now and activate your 12 month guarantee

Thank you for choosing Bush. Your new product is guaranteed against faults and breakdowns for 12 months. Don't forget to register it with us today so we can provide you with our best possible after-sales service and useful updates.

**[www.bushregistration.co.uk](http://www.bushregistration.co.uk)**

FREEPHONE\*

**0800 597 8548**

Lines are open 8am - 8pm, 365 days a year. \*Calls may be recorded and monitored.

## Your Bush Guarantee

This product is guaranteed for twelve months from the date of original purchase. Any defect that arises due to faulty materials or workmanship will be repaired free of charge (or if applicable the product will be replaced or the purchase price refunded) where possible during this period by the dealer from who your purchased the unit.

The guarantee is subject to the following provisions:

- The guarantee does not cover accidental damage, misuse, cabinet parts, knobs or consumable items.
- The product must be correctly installed and operated in accordance with the instructions contained in the manual.
- It must be used solely for domestic purposes. The guarantee will be rendered invalid if the product is re-sold or has been damaged by inexpert repair.
- Specifications are subject to change without notice.
- Bush disclaim any liability for loss or damage arising from the breakdown of the product.
- This guarantee is in addition to and does not diminish your statutory or legal rights.

## Important Data Protection Information

If you provide us with information about another person, you confirm that they have appointed you to act for them, to consent to the processing of their personal data including sensitive personal data and that you have informed them of our identity and the purposes (as set out in the Important Data Privacy notice displayed overleaf) for which their personal data will be processed.

You are entitled to ask for a copy of the information we hold about you (for which we may charge a small fee) and to have any inaccuracies in your information corrected.

For quality control and training purposes, we may monitor or record your communications with us.

If your personal details change, if you change your mind about any of your marketing preferences or if you have any queries about how we use your information, please let us know by contacting our Data Protection Officer, Domestic & General, Leicester House 17 Leicester Street, Bedworth, Warwickshire CV12 8JP.

Guarantor: Argos Limited - 489 - 499 Avebury Blvd. - Milton Keynes - MK9 2NW

or online at [www.argos-support.co.uk](http://www.argos-support.co.uk) If you still require further assistance, call one of our experts on **0345 604 0105**.

# BUSH

## Contact:

[www.argos-support.co.uk](http://www.argos-support.co.uk)

Helpline: 0345 604 0105

