



VOLT XT1 ELECTRIC SCOOTER QUICK START GUIDE



info@hy-pro.co.uk
Customer care line Tel: 0800 731 0006

Please retain for future reference
Made in China



STEP 1

1. Lift the frame's front wheel assembly and align the curved steering tube with the locator hole in the deck frame. Insert the lock bolt and nut into the locator hole. Tighten the lock bolt and nut with two 5mm hex wrenches.

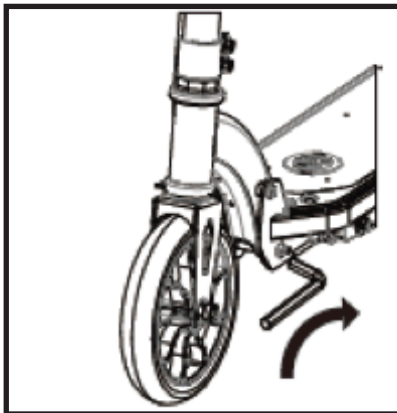

STEP 3

1. Align the handlebar vertically and horizontally onto the handlebar stem's clamp, align the handlebar top clamp, and insert the bolts and nuts. Adjust the handlebar and tighten the bolts and nuts evenly and securely with the 5mm hex wrench and 8mm/10mm spanner. The throttle should be in your right hand as you stand on the scooter's deck.



STEP 2

1. Depress the push button located on the rear of the fork as shown in above picture and insert the handlebar stem until the button locks securely into the forks.

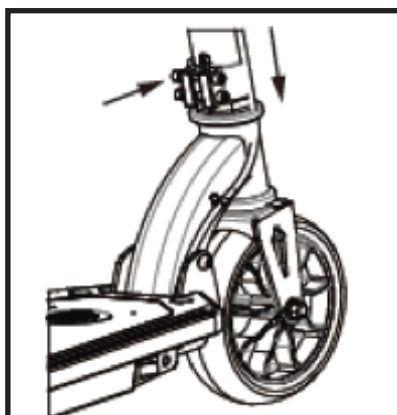

STEP 4

Charging the battery

1. Make sure power switch is in the OFF position before plugging in the charger. Insert charger into the charging port on the right side of the battery box.

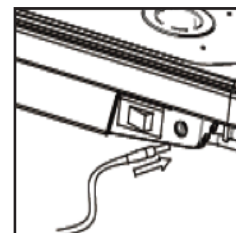

2. Plug the charger into a wall power outlet. The light on the charger housing should illuminate. Red LED light indicates battery is charging and a green LED light indicates battery is fully charged.

The scooter MUST ALWAYS be switched OFF while being charged

Your electric scooter will not have a fully charged battery.

Initial battery charge time: at least 12 hours.

Runtime: up to 60 minutes run time

Recharge time: at least 5 hours after the initial 12 hours charge time.

BATTERY INFORMATION

Batteries have a capacity memory which is why the initial charge is very important for this product.

The initial charge will be memorised, therefore ZINC would like to remind you:

PLEASE CHARGE YOUR SCOOTER for a minimum of 12hrs before the first use.

To prolong the life of the battery in this scooter, please ensure you charge your scooter every two weeks even if it has not been used.

Before assembly:

1. Ensure you have all the required tools:

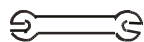

1x 8mm/10mm
Spanner
(Included)

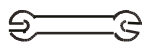

1x 13mm
Spanner
(Not included)

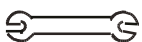

1x 12mm
Spanner
(Not included)

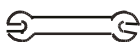

1x 17mm
Spanner
(Not included)



1 x 2.5mm
Hexagon Wrench (Included)



2 x 5mm
Hexagon Wrench
(Included)



1 x 4mm
Hexagon Wrench
(Not included)



1 x Phillips Head
Screwdriver (Not included)

2. Tighten the bolts evenly and securely with the 5mm hex wrench and 8mm/10mm spanner.

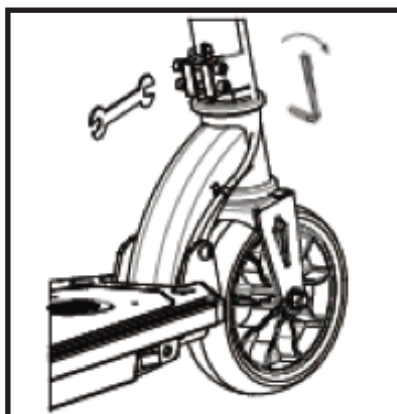

STEP 5 (only if required)

Replacing/tightening the accelerator grip.

1. Unscrew and slide out the handle grip.
2. Replace the metal ring.
3. Insert the handle grip and align the holes.
4. Insert and tighten the screw with 2.5mm hex wrench.

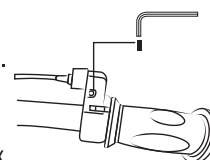

Warning! Controller will auto cut the circuit if overloaded or encounters a steep slope - to protect the motor. Wait a few seconds, and then press the reset button to reset the circuit. Avoid repeatedly tripping the reset button.