

Range Kitchen - Corner Base Cabinet

Assembly Instructions - Please keep for future reference

656/5800

hygena

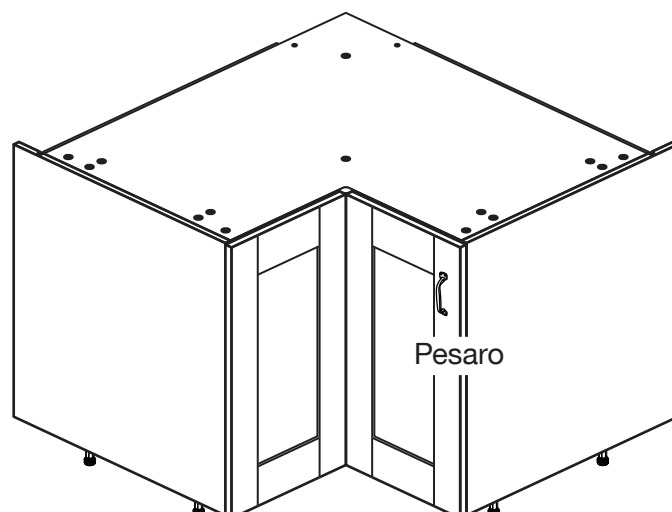
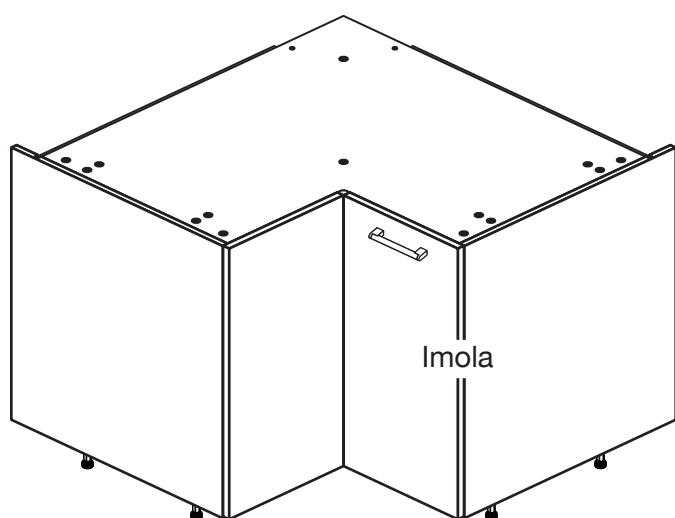
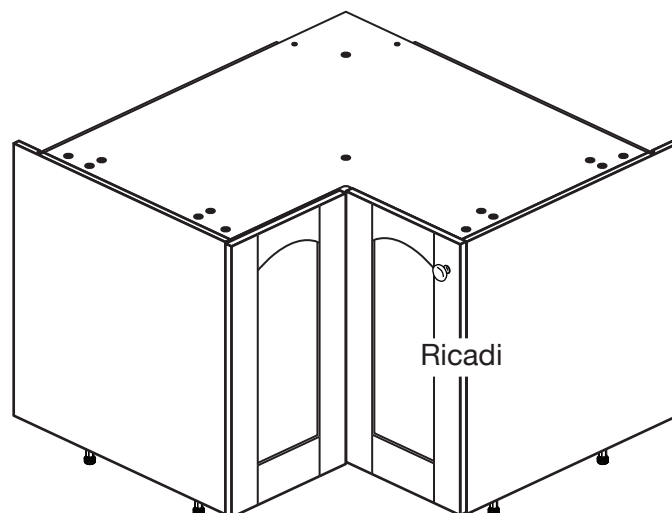
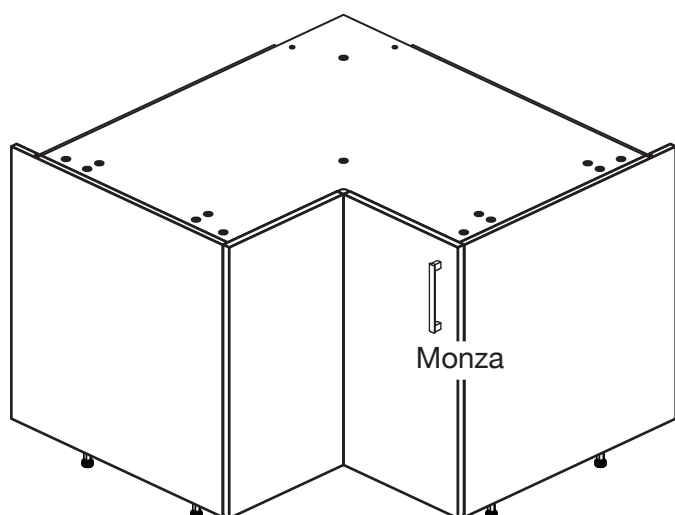

Dimensions

Width - 88cm

Depth - 88cm

Height - 87cm



**MADE IN
BRITAIN**

Important - Please read these instructions fully before starting assembly

If you need help or have damaged or missing parts, call the **Customer Helpline: 08456 400800**



Safety and Care Advice

Important - Please read these instructions fully before starting assembly

- **Warning:** This unit weighs approximately 34kgs. Please lift with care.

- Check you have all the components and tools listed on pages 2 to 5.

- Remove all fittings from the plastic bags and separate them into their groups.

- Keep children and animals away from the work area, small parts could choke if swallowed.

- Parts of the assembly will be easier with 2 people.

- Make sure you have enough space to layout the parts before starting.

- Do not stand or put weight on the product, this could cause damage.

- Assemble the item as close to its final position (in the same room) as possible.

- Assemble on a soft level surface to avoid damaging the unit or your floor (use opened out unit carton).



- We do not recommend the use of power drill/drivers **for inserting screws**, as this could damage the unit. Only use hand screwdrivers.

- **Safety note:** If there is any chance of this unit being pulled over by children etc. it is recommended that the unit is secured to a wall using suitable fixings (not supplied).

- Dispose of all packaging carefully and responsibly.

Care and maintenance

- Only clean using a damp cloth and mild detergent, do not use bleach or abrasive cleaners.

- From time to time check that there are no loose screws on this unit.

- This product should not be discarded with household waste. Take to your local authority waste disposal centre.

Note: If required the next page can be cut out and used as reference throughout the assembly. Keep this page with these instructions for future reference.

Components - Panels

If you have damaged or missing components, call the
Customer Helpline: 08456 400800 quoting the reference
numbers below

Please check you have all the panels listed below

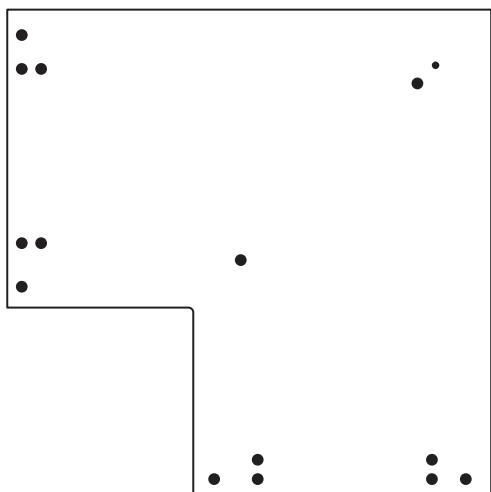

1 Top/Base (DPF136A)
(800 x 800mm) x 2

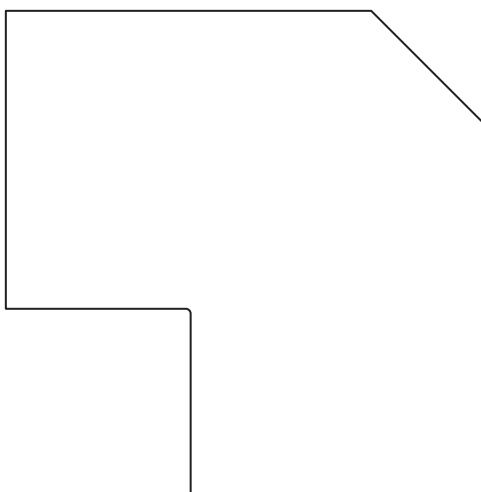

2 Loose Shelf (DPF137A)
(798 x 798mm)

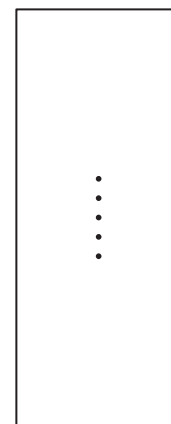

3 Back (DPF138A)
(272 x 688mm)

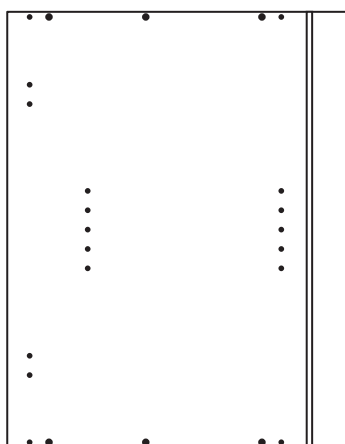

4 Left Side (DPF177A)
(720 x 560mm)

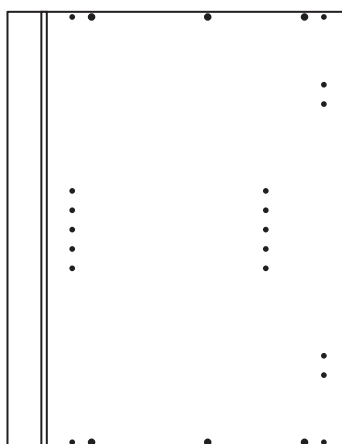

5 Right Side (DPF178A)
(720 x 560mm)

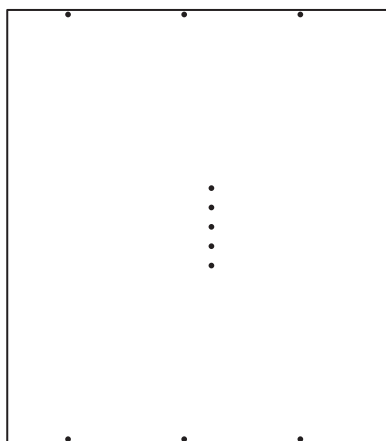

6 Left Back (DPF139A)
(630 x 717mm)

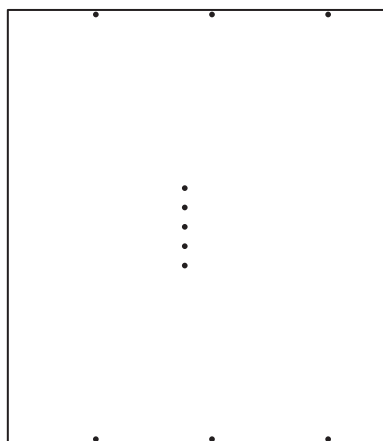

7 Right Back (DPF140A)
(630 x 717mm)











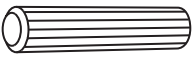
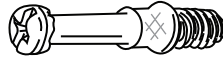

Components - Fittings

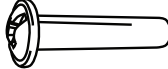
If you have damaged or missing components, call the
Customer Helpline: 08456 400800 quoting the reference
 numbers below

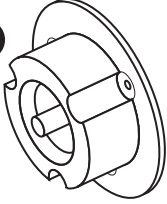
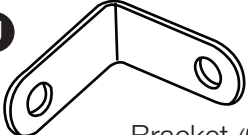
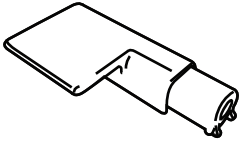
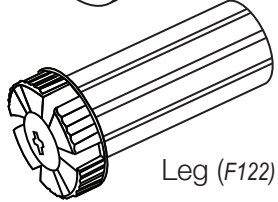
Please check you have all the fittings listed below

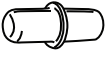
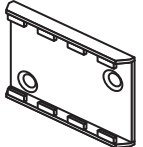
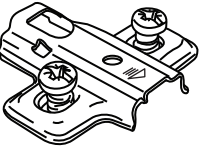
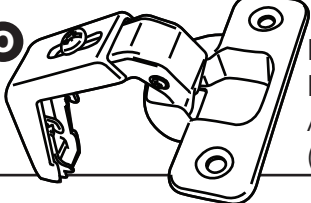
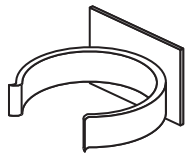
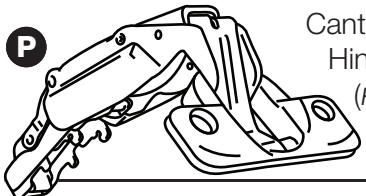
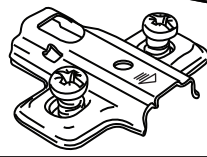
Note: The quantities below are the correct amount to complete the assembly. In some cases more fittings may be supplied than are required.

<p>A </p> <p>Wooden dowel (F22) x 16</p>	<p>B </p> <p>Metal dowel (F901) x 8</p>	<p>C </p> <p>Large locking nut (F900) x 8</p>
<p>D </p> <p>13mm Screw (F63) x 8</p>	<p>E </p> <p>13mm Screw (F79) x 2</p>	<p>F </p> <p>25mm Screw (F50) x 18</p>
<p>G </p> <p>Connecting Sleeve (F432) x 2</p>	<p>H </p> <p>19mm Connecting bolt (F461) x 2</p>	<p>I a </p> <p>Leg Socket (F120) x 6</p>
<p>J </p> <p>Bracket (F945) x 2</p>	<p>K </p> <p>Soft Close Unit (F156) x 2</p>	<p>I b </p> <p>Leg (F122) x 6</p>
<p>L </p> <p>40mm Screw (F910) x 2</p>	<p>M </p> <p>Shelf support (F110) x 7</p>	<p>I c </p> <p>Leg Bracket (F127) x 3</p>
<p>N </p> <p>2mm Hinge Plate (F157) x 2</p>	<p>O </p> <p>Bent Hinge Arm (F154) x 2</p>	<p>I d </p> <p>Leg Clip (F128) x 3</p>
<p>P </p> <p>Cantilevered Hinge Arm (F155) x 2</p>	<p>Q </p> <p>4mm Hinge Plate (F158) x 2</p>	<p>I e </p> <p>16mm Screw (F129) x 24</p>

Components - Doors

If you have damaged or missing components, call the **Customer Helpline: 08456 400800** quoting the reference numbers below

Please check you have all the panels listed below

Doors and handles are supplied separately in fascia packs.

Please see below for the correct fascia code for this unit in your chosen fascia design.

Monza Oak	656/6304
Monza Beech	656/6294
Imola Black Gloss	656/6311
Imola Cream Gloss	656/6335
Imola White Gloss	656/6328
Pesaro Cream	656/6359
Pesaro Oak	656/6342
Ricadi	656/6366

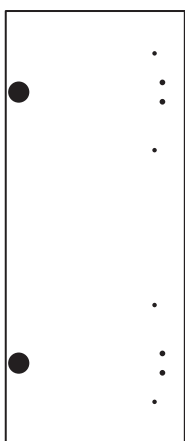

8 Monza Door (DPF114A)
(296 x 716mm) x 2

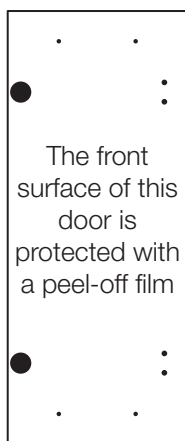

8 Imola Door (DPF114A)
(296 x 716mm) x 2

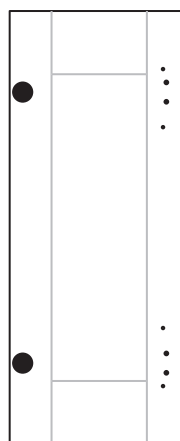

8 Pesaro Door (DPF114A)
(296 x 716mm) x 2

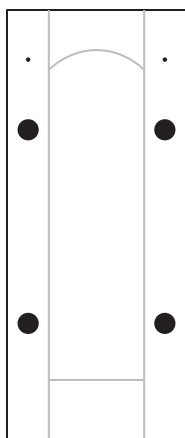

9 Ricadi Hinged Door (D0449A)
(296 x 716mm)

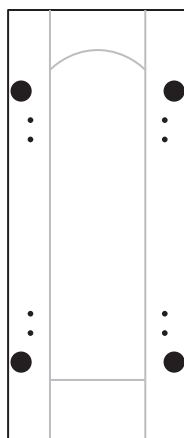

10 Ricadi Carcase Door (D0449A)
(296 x 716mm)







Components - Handles

If you have damaged or missing components, call the **Customer Helpline: 08456 400800** quoting the reference numbers below

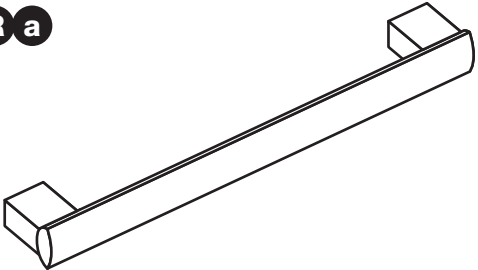
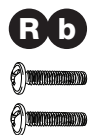
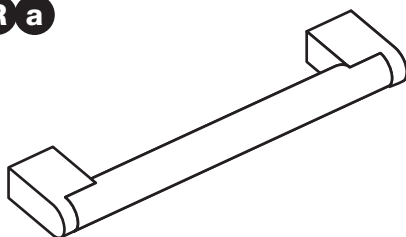
Please check you have all the fittings listed below

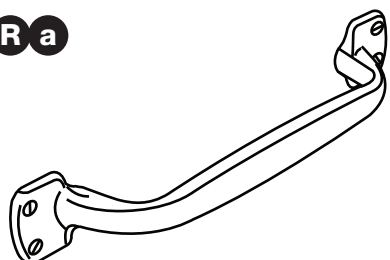
Handles are supplied separately and are located packed in the end sleeve of each fascia pack. Please see below for the correct fascia code for this unit in your chosen fascia design.

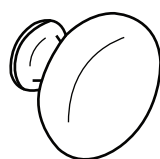
Monza Oak	656/6304
Monza Beech	656/6294
Imola Black Gloss	656/6311
Imola Cream Gloss	656/6335
Imola White Gloss	656/6328
Pesaro Cream	656/6359
Pesaro Oak	656/6342
Ricadi	656/6366

<p>R a</p>  <p>Monza Door Handle (F123) x 1</p> <p>R b</p>  <p>25mm Screw (F132) x 2</p>	<p>R a</p>  <p>Imola Door Handle (F124) x 1</p> <p>R b</p>  <p>25mm Screw (F132) x 2</p>
<p>R a</p>  <p>Pesaro Door Handle (F125) x 1</p> <p>R b</p>  <p>25mm Screw (F132) x 2</p>	<p>R a</p>  <p>Ricadi Door Handle (F126) x 1</p> <p>R b</p>  <p>25mm Screw (F132) x 1</p> <p>R c</p>  <p>Hole Plug (F114) x 4</p>

Assembly Instructions

If you have damaged or missing components, call the Customer Helpline: 08456 400800 quoting the reference numbers below

Step 1

Choose which way you would like the door to open

You can fit the door to the left side or right side.

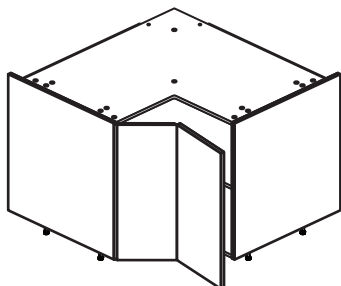

If you would like your door to open this way, fit the hinge plates to the left side

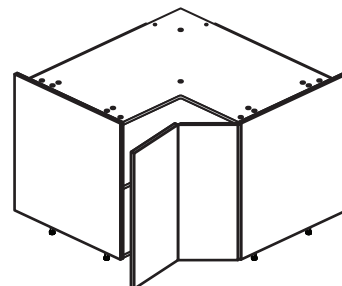

If you would like your door to open this way, fit the hinge plates to the right side

Step 2

Prepare the left side

Refer to step 1 and, if required, fit 2 hinge plates **Q** onto the left side **4**, making sure that they face the same way as the diagram.

Screw 4 metal dowels **B** into the holes shown on the left side **4**.

Note: Tighten metal dowels up fully against the panels.

Fit a bracket **J** flush to the top and back edge of the left side **4**.

Secure the bracket **J** using screw **E**.

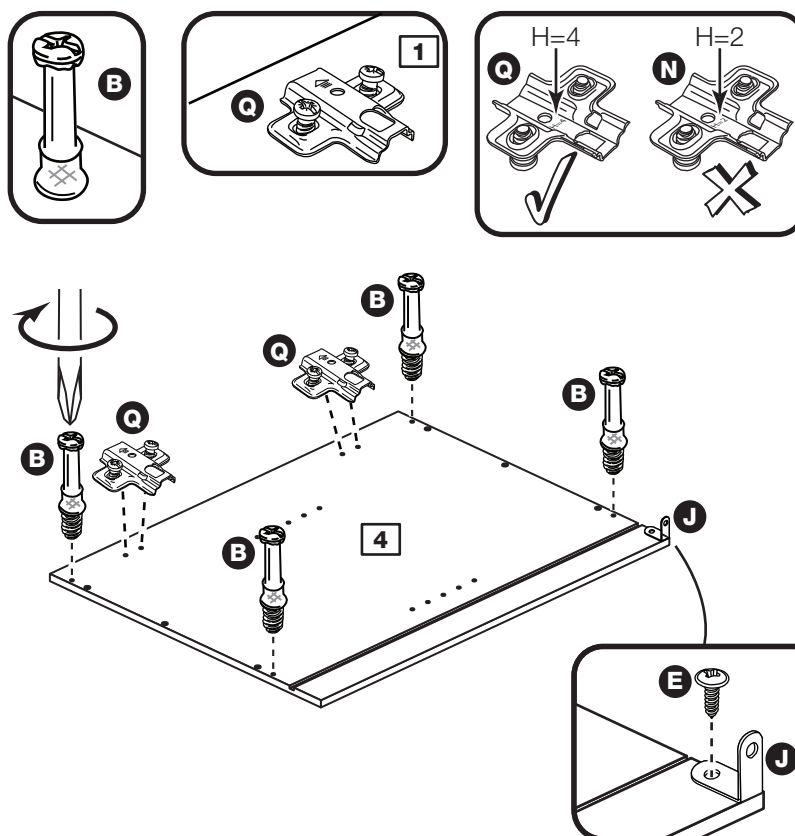

Assembly Instructions

Step 3

Prepare the right side

Refer to step 1 and, if required, fit 2 hinge plates **Q** onto the right side **5**, making sure that they face the same way as the diagram.

Screw 4 metal dowels **B** into the holes shown on the right side **5**.

Note: Tighten metal dowels up fully against the panels.

Fit a bracket **J** flush to the top and back edge of the right side **5**.

Secure the bracket **J** using screw **E**.

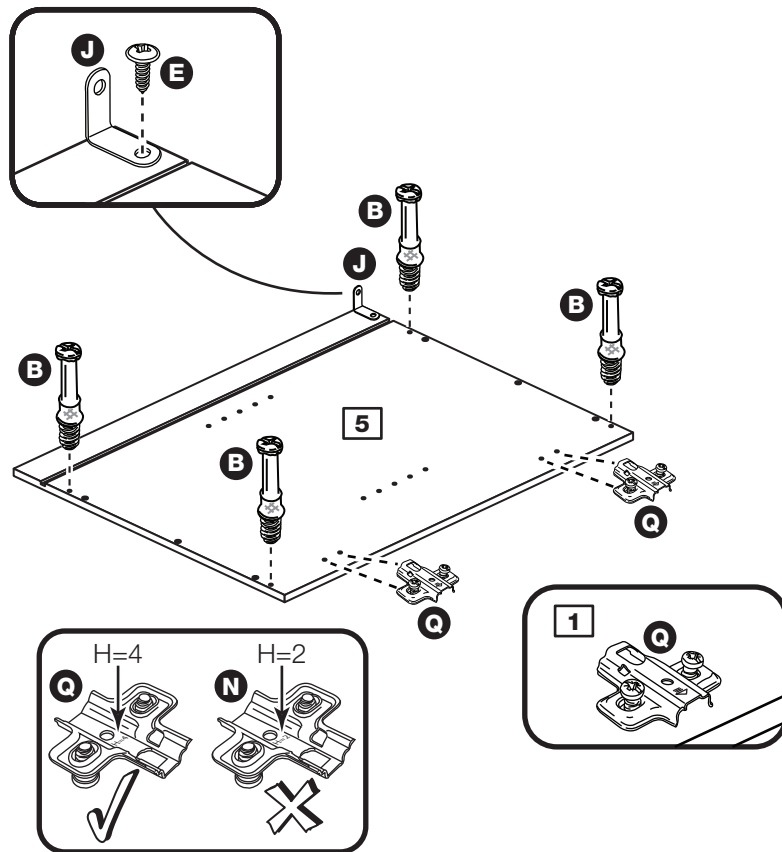

Step 4

Prepare the top and base

Insert 4 large locking nuts **C** into the top **1** and base **1** as shown.

Note: Arrow on locking nut **must** point towards hole in edge of panel.

Tap 6 wooden dowels **A** into the top **1** and base **1** as shown.

Note: Wooden dowels **must not** stick out from the edge by more than 10mm or they may damage other panels.

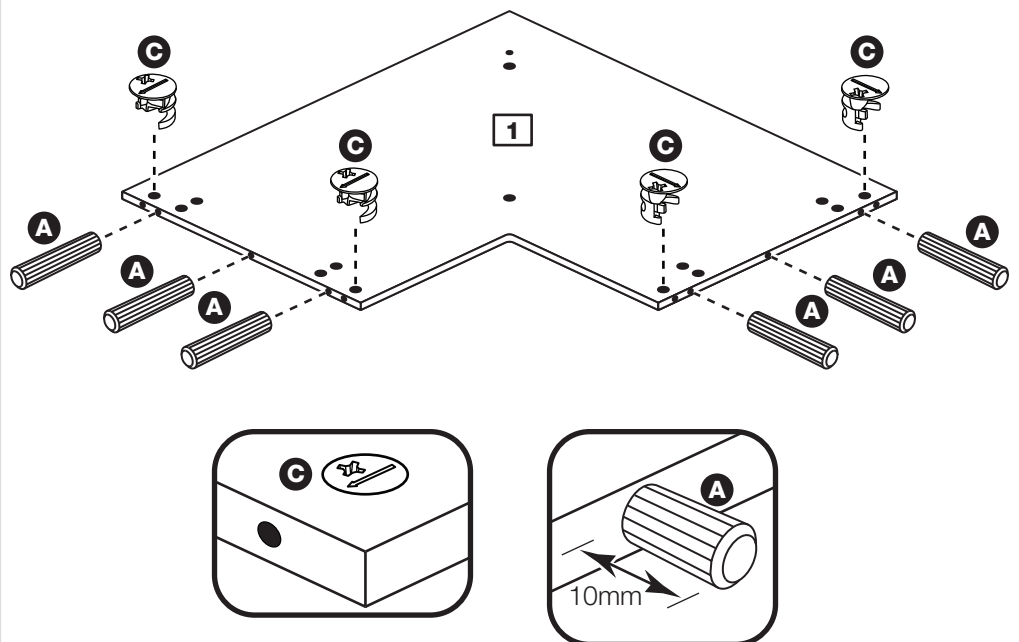

Assembly Instructions

Step 5

Fit the legs to the base

a: Push the leg sockets **la** into the holes in the base **1** as shown.

b: Secure each leg socket **la** with 3 screws **le**.

c: Tap in the centre plug on each leg socket **la**.

d: Push the leg **lb** into the leg socket **la**.

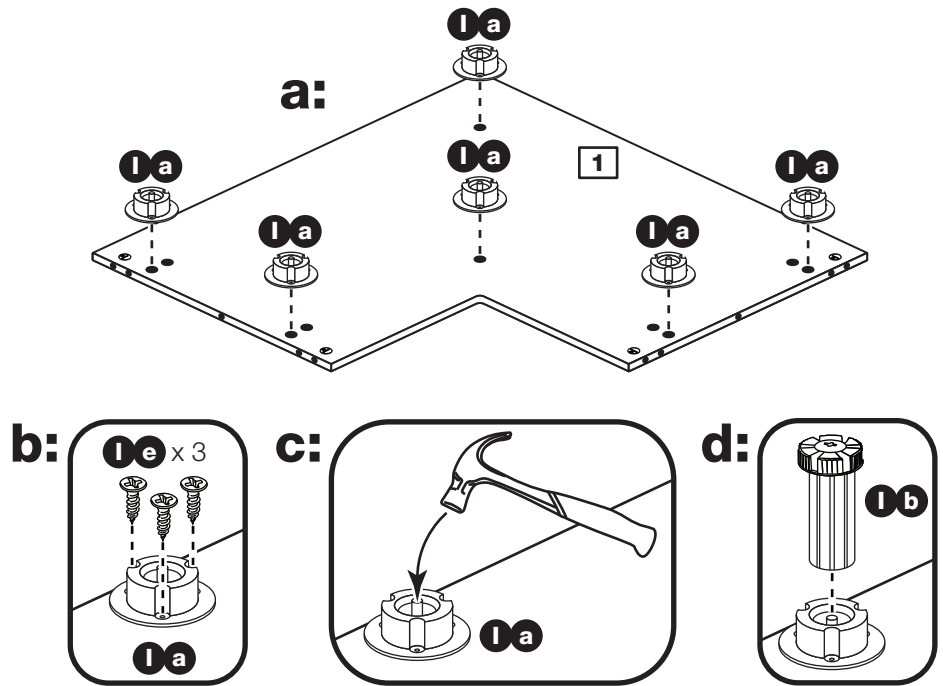

Step 6

Join the right side and base

Push the base **1** onto the right side **5**.

Use a screwdriver to tighten the 2 large locking nuts **C** fitted to the base **1**.

Note: Turn the large locking nuts **C** as far as they will go - more than 1/2 a turn.

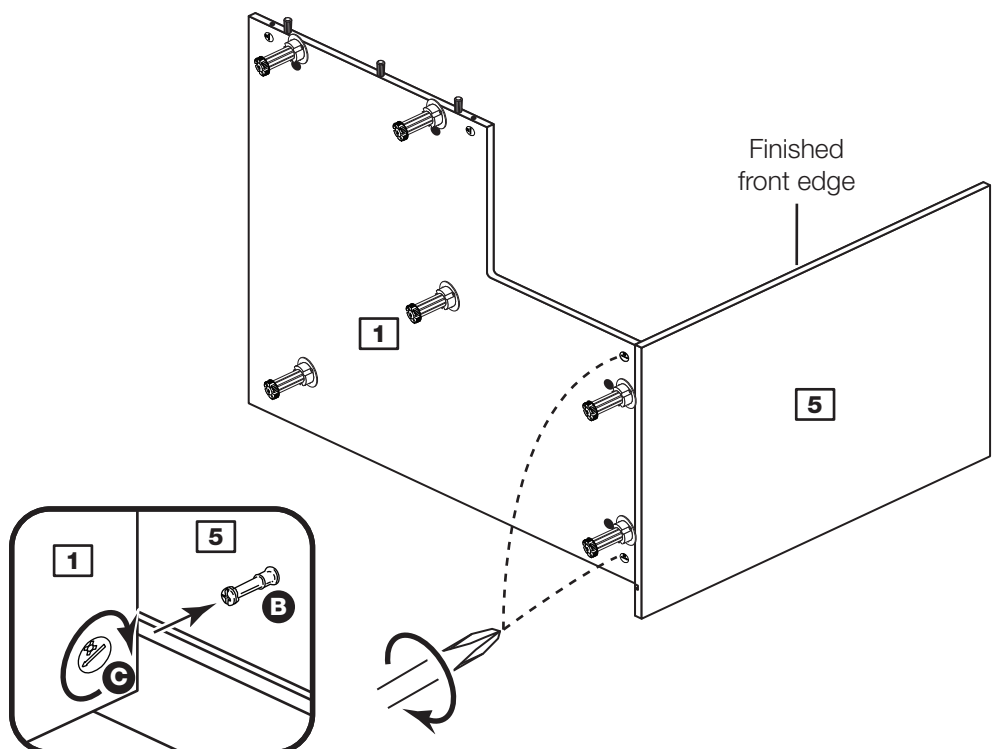

Assembly Instructions

Step 7

Prepare the back

Tap 4 wooden dowels **A** into the back **3** as shown.

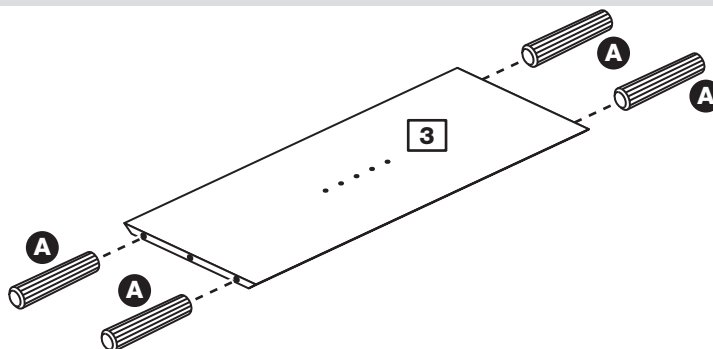

Step 8

Fit the back

Push the back **3** onto the base **1** and secure with screw **L**.

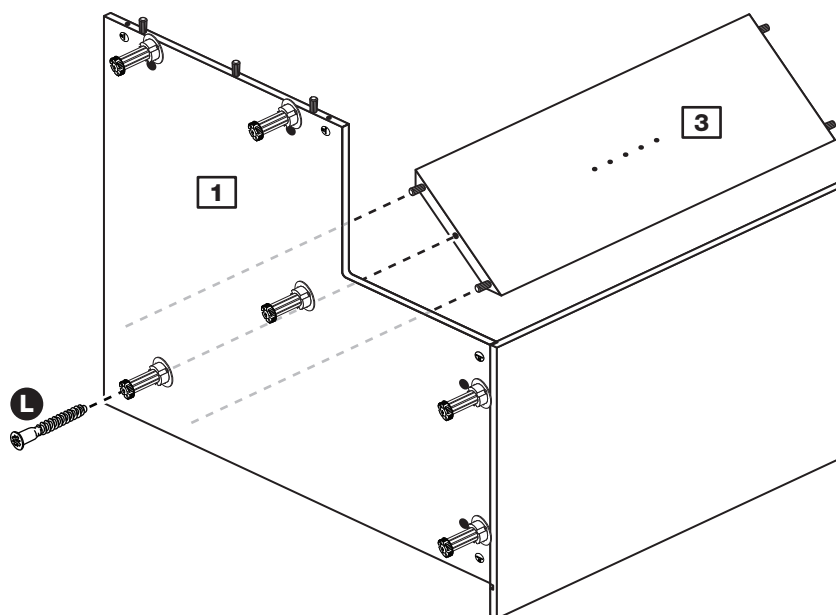

Step 9

Fit the top

Push the top **1** onto the right side **5** and back **3**.

Use a screwdriver to tighten the 2 large locking nuts **C** fitted to the top **1**.

Note: Turn the large locking nuts **C** as far as they will go - more than 1/2 a turn.

Secure the back **3** to the top **1** with screw **L**.

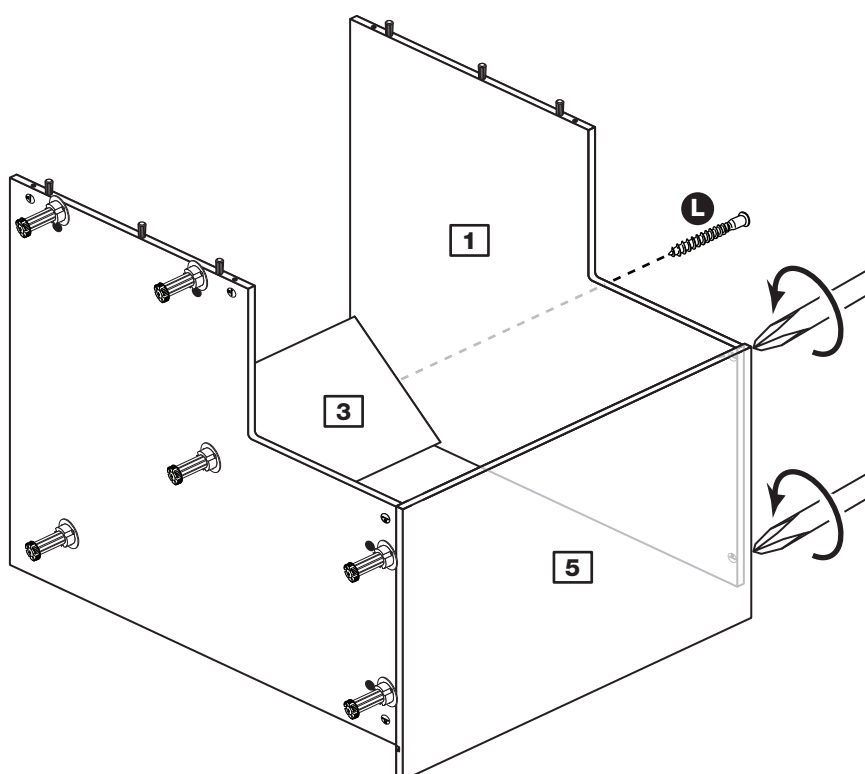

Assembly Instructions

Step 10

Insert the loose shelf

Place the loose shelf **2** inside the unit.

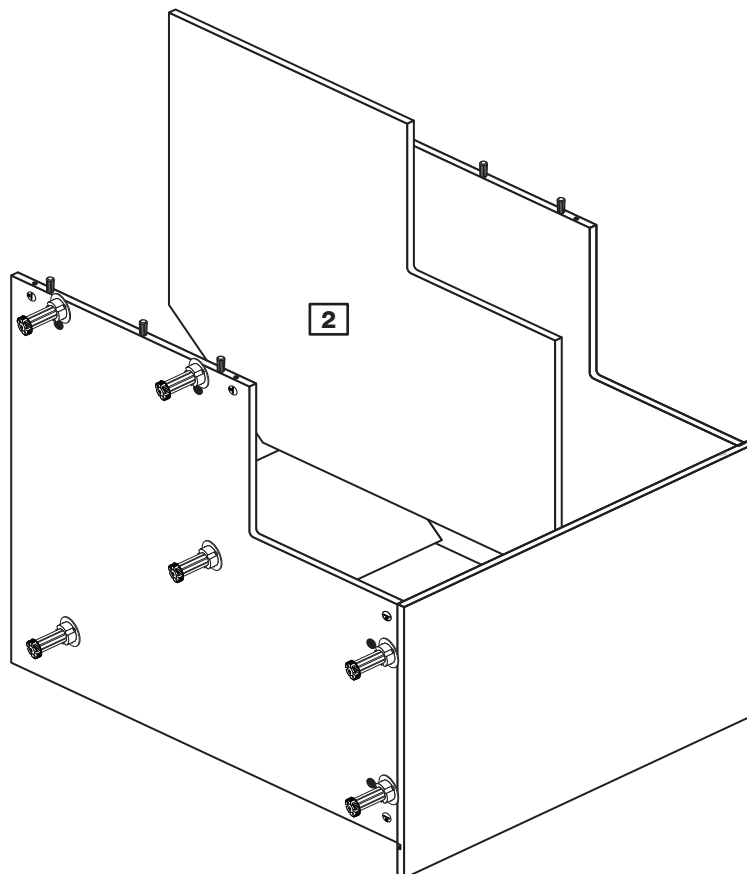

Step 11

Fit the left side

Push the left side **4** onto the base **1** and top **1**.

Use a screwdriver to tighten the 4 large locking nuts **C** fitted to the base **1** and top **1**.

Note: Turn the large locking nuts **C** as far as they will go - more than 1/2 a turn.

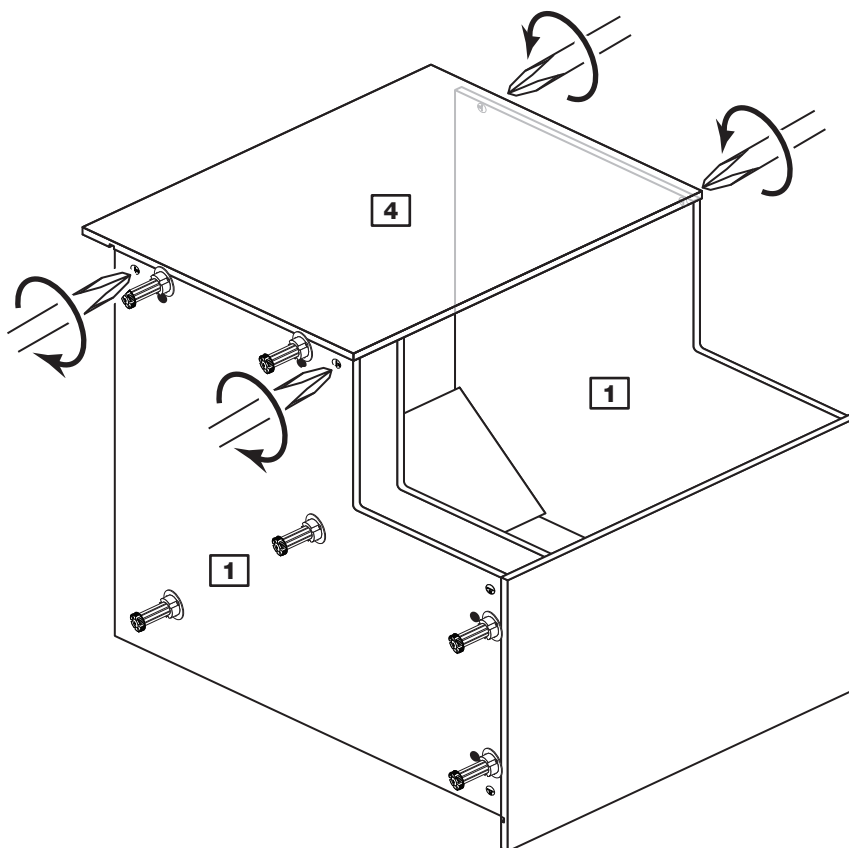

Assembly Instructions

Step 12

Fit left back

Slide the left back **6** along the groove in the left side.

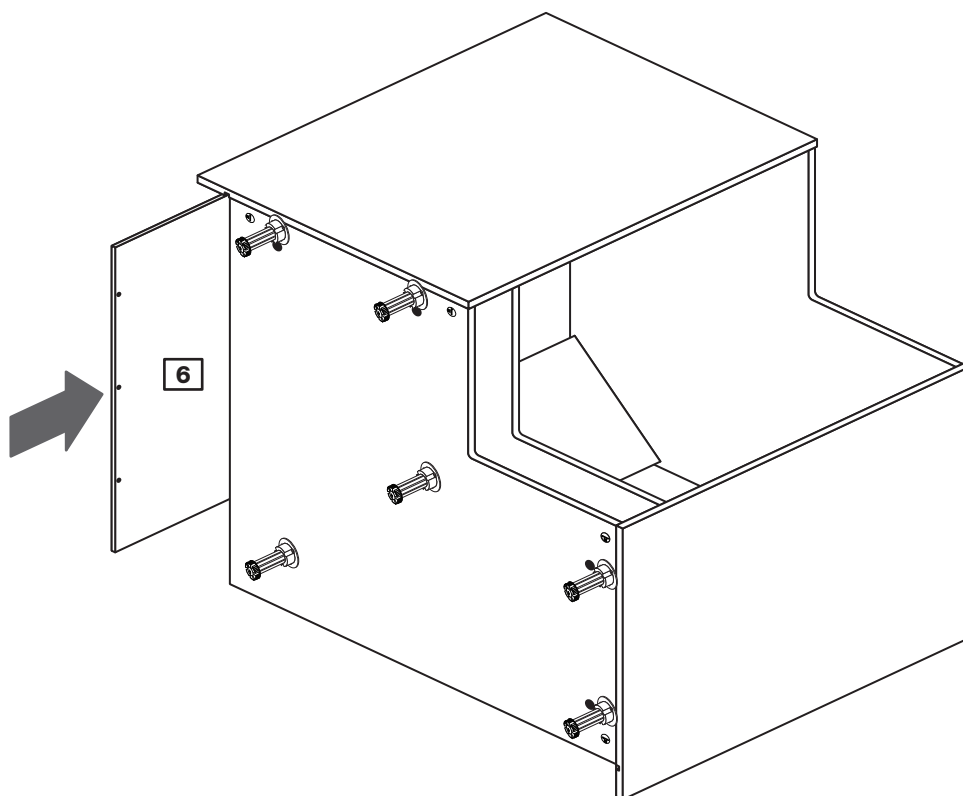

Step 13

Secure the left back

Secure the left back **6** with 6 screws **F** through its pre-drilled holes into the base and top.

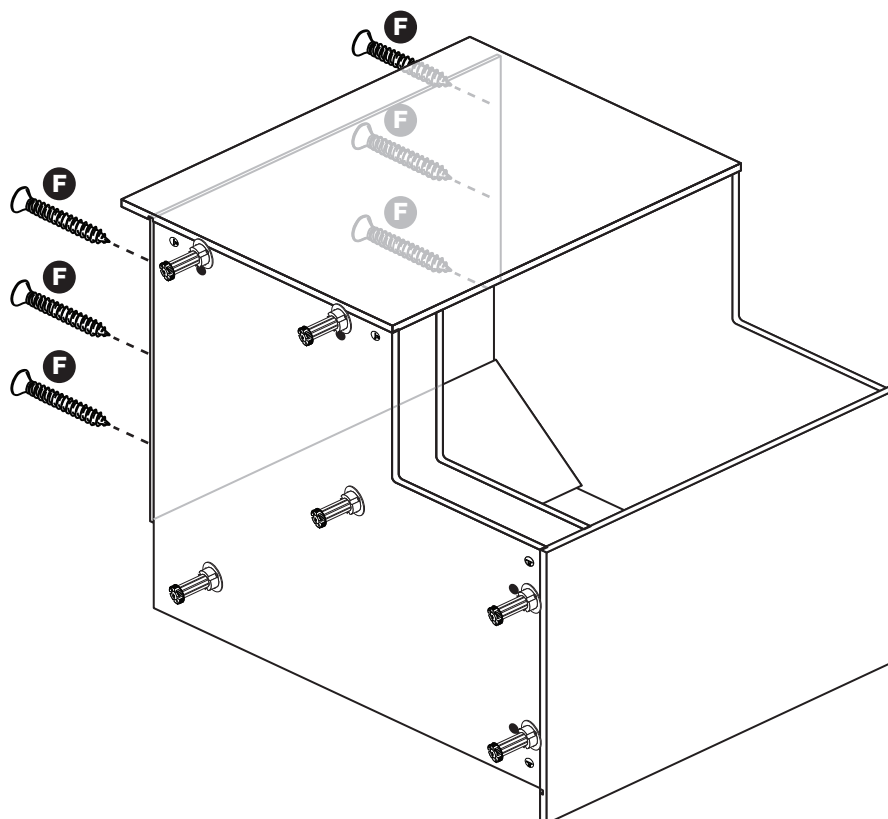

Assembly Instructions

Step 14

Fit right back

Slide the right back **7** along the groove in the right side.

Secure the right back **7** with 6 screws **F** through its pre-drilled holes into the base and top.

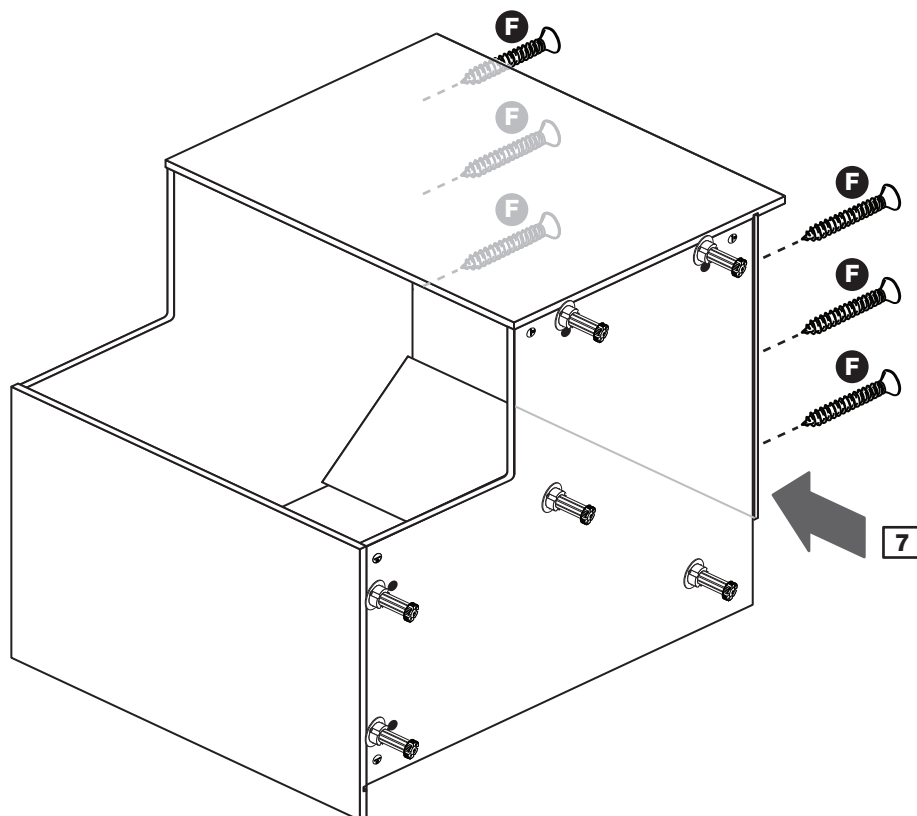

Step 15

Fit the loose shelf

Hold the loose shelf **2** up and insert 7 shelf studs **M** at the required height.

Lower the loose shelf **2** down onto the shelf studs **M**.

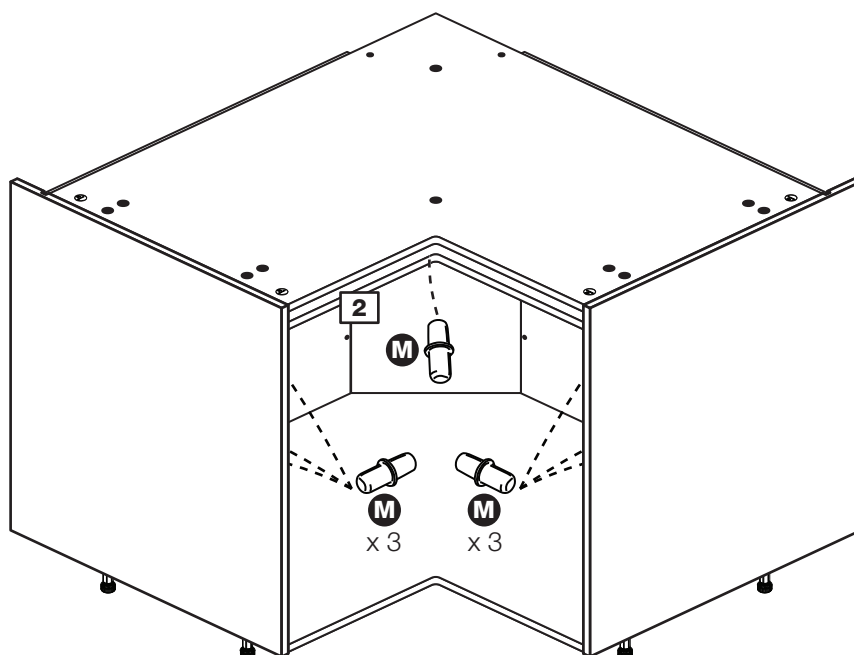

Assembly Instructions

Step 16

Prepare the doors

a: Fit 2 hinge plates **N** onto a door **8**, making sure that they face the same way as the diagram.

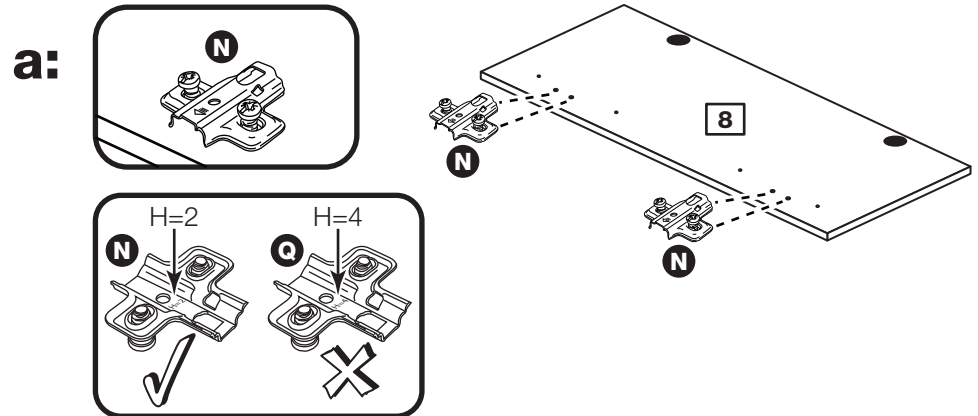

b: Push fit 2 cantilevered hinge arms **P** into the door **8**.

Secure each hinge arm with 2 screws **D**.

Note: Before securing with the screws, make sure that the hinges are positioned at 90 degrees with the front edge of the door.

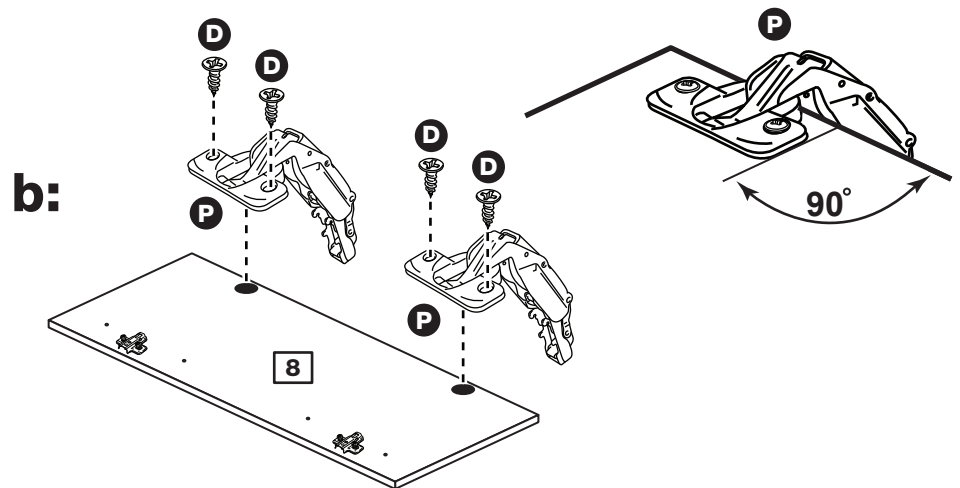

c: Push fit 2 bent hinge arms **O** into the other door **8**.

Secure each hinge arm with 2 screws **D**.

Note: Before securing with the screws, make sure that the hinges are positioned at 90 degrees with the front edge of the door.

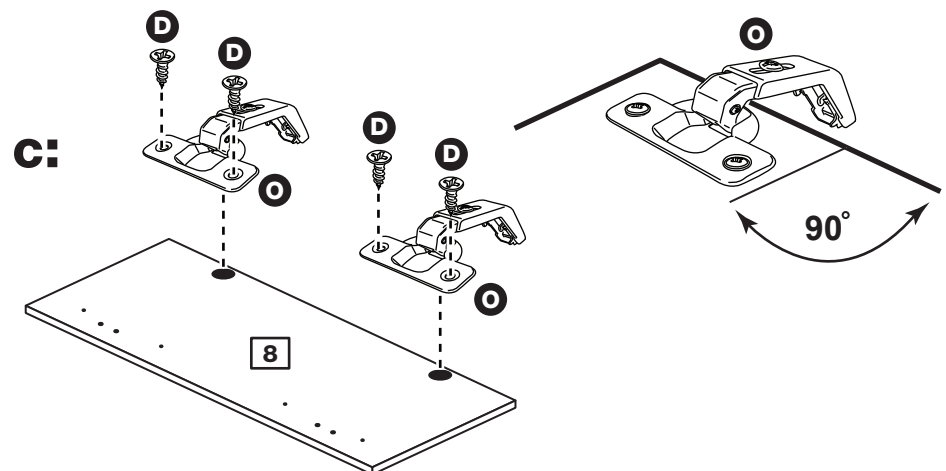

Assembly Instructions

Step 17

Prepare the doors

a: Fit 2 hinge plates **N** onto the carcass door **10**, making sure that they face the same way as the diagram.

b: Push fit 2 cantilevered hinge arms **P** into the carcass door **10**.

Secure each hinge arm with 2 screws **D**.

Note: Before securing with the screws, make sure that the hinges are positioned at 90 degrees with the front edge of the door.

Push hole plugs **Rc** into the 2 unused hinge holes.

c: Push fit 2 bent hinge arms **O** into the hinged door **9**.

Secure each hinge arm with 2 screws **D**.

Note: Before securing with the screws, make sure that the hinges are positioned at 90 degrees with the front edge of the door.

Push hole plugs **Rc** into the 2 unused hinge holes.

RICARDI DOORS ONLY - LEFT SIDE HINGE PLATES

Only follow this step if you have fitted the hinge plates to the LEFT side (see step 1).

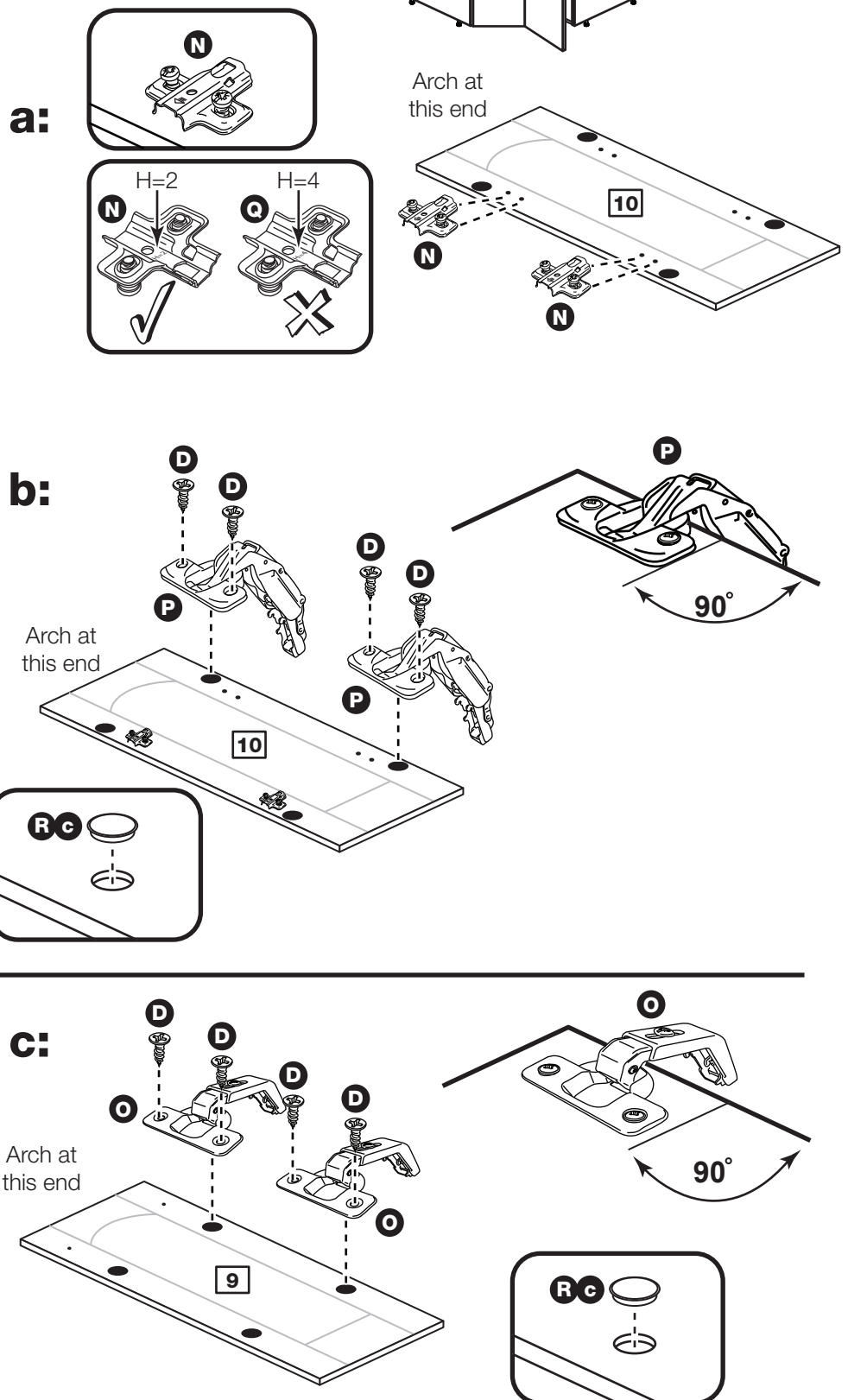

Assembly Instructions

Step 18

Prepare the doors

a: Fit 2 hinge plates **N** onto the carcass door **10**, making sure that they face the same way as the diagram.

b: Push fit 2 cantilevered hinge arms **P** into the carcass door **10**.

Secure each hinge arm with 2 screws **D**.

Note: Before securing with the screws, make sure that the hinges are positioned at 90 degrees with the front edge of the door.

Push hole plugs **Rc** into the 2 unused hinge holes.

c: Push fit 2 bent hinge arms **O** into the hinged door **9**.

Secure each hinge arm with 2 screws **D**.

Note: Before securing with the screws, make sure that the hinges are positioned at 90 degrees with the front edge of the door.

Push hole plugs **Rc** into the 2 unused hinge holes.

RICARDI DOORS ONLY - RIGHT SIDE HINGE PLATES

Only follow this step if you have fitted the hinge plates to the RIGHT side (see step 1).

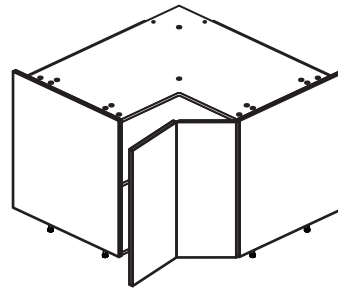

a:

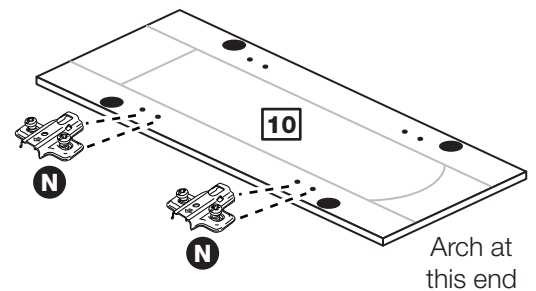
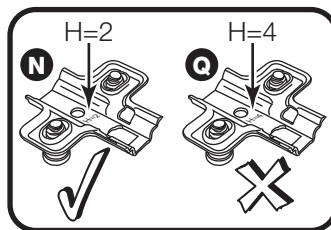
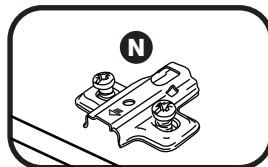

b:

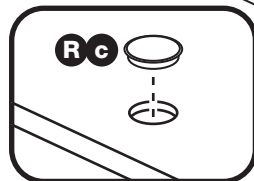
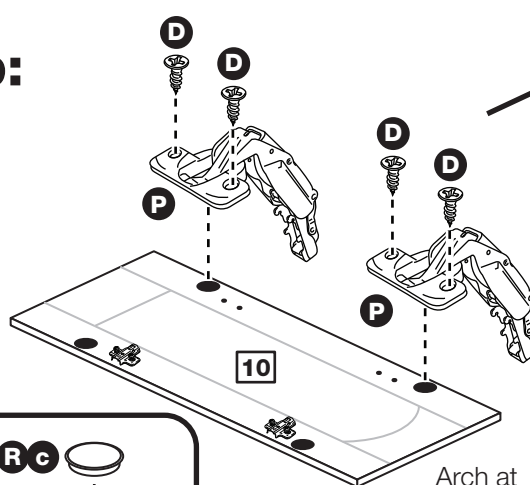

c:

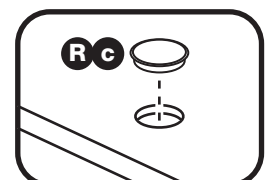
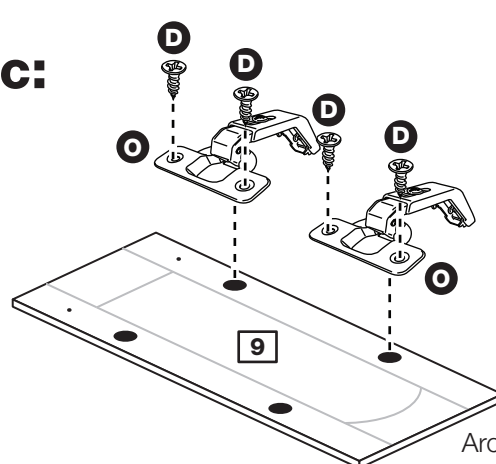

Assembly Instructions

Step 19

Drill the handle holes in the door

Important: Please follow these instructions carefully.

Lay the door **8** down onto a smooth surface.

Important: Carefully choose which holes you need to drill. This will depend on which side **1** or **2** you fitted the hinge plates **N**.

Check that the holes and hinges are in the same place as the diagrams.

Note: We recommend the use of a small piece of waste wood, placed behind the hole while drilling, to reduce the possibility of any breakout.

Using the pilot hole in the rear face of the door, **8** drill through the holes indicated opposite, using a 2.5mm diameter drill.

Turn the door **8** over and open out the 2.5mm holes that you have just drilled by drilling back through them with a 5mm drill.

Note: Drill bits are not provided.

MONZA DOOR ONLY

Carefully choose which 2 holes you will need to drill

Drill these 2 holes if you have fitted the hinges to the left side.

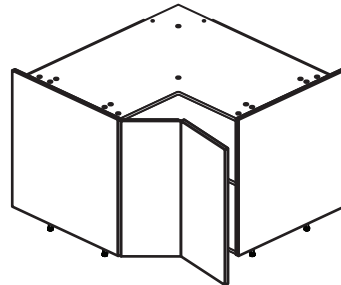

ONLY drill these 2 holes

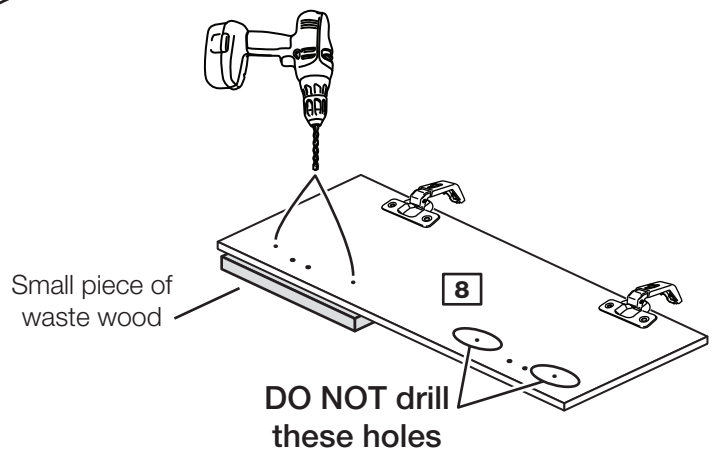

or

Drill these 2 holes if you have fitted the hinges to the right side.

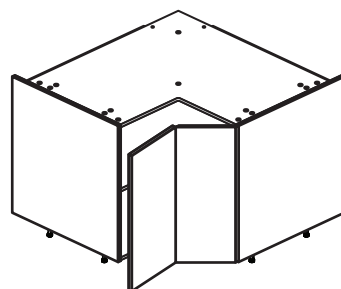

ONLY drill these 2 holes

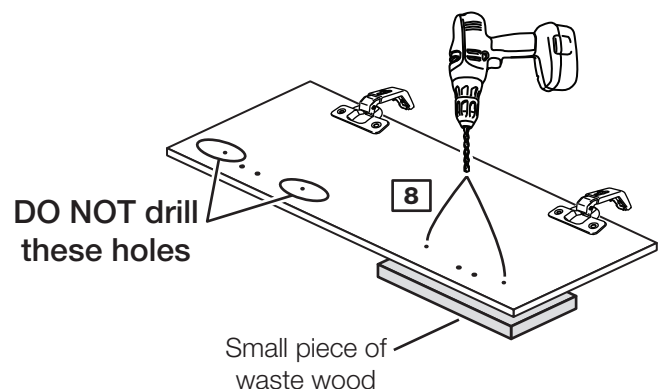

Assembly Instructions

Step 20

Drill the handle holes in the door

Important: Please follow these instructions carefully.

Lay the door **8** down onto a smooth surface.

Important: Carefully choose which holes you need to drill. This will depend on which side **1** or **2** you fitted the hinge plates **N**.

Check that the holes and hinges are in the same place as the diagrams.

Note: We recommend the use of a small piece of waste wood, placed behind the hole while drilling, to reduce the possibility of any breakout.

Using the pilot hole in the rear face of the door, **8** drill through the holes indicated opposite, using a 2.5mm diameter drill.

Turn the door **8** over and open out the 2.5mm holes that you have just drilled by drilling back through them with a 5mm drill.

Note: Drill bits are not provided.

IMOLA DOOR ONLY

Carefully choose which 2 holes you will need to drill

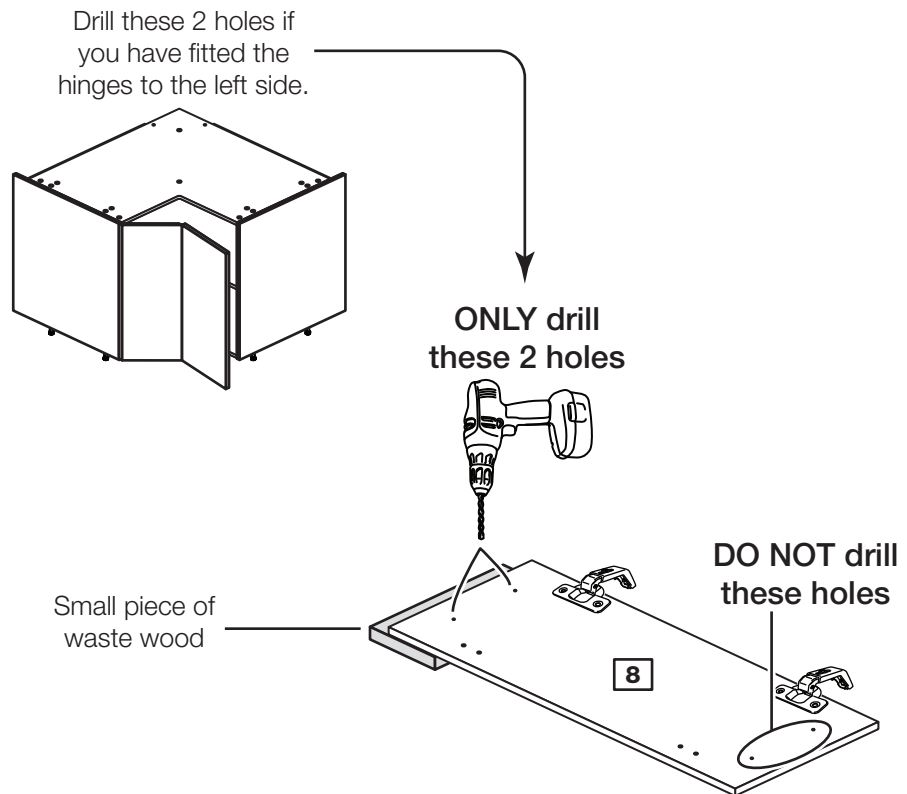

or

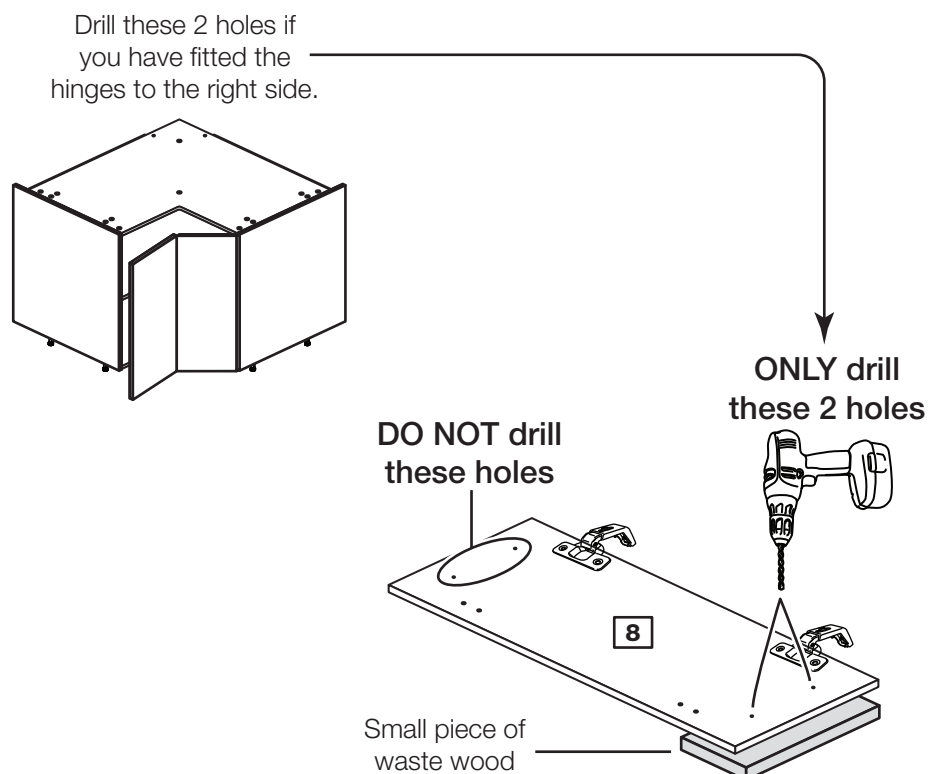

Assembly Instructions

Step 21

Drill the handle holes in the door

Important: Please follow these instructions carefully.

Lay the door **8** down onto a smooth surface.

Important: Carefully choose which holes you need to drill.

This will depend on which side **1** or **2** you fitted the hinge plates **N**.

Check that the holes and hinges are in the same place as the diagrams.

Note: We recommend the use of a small piece of waste wood, placed behind the hole while drilling, to reduce the possibility of any breakout.

Using the pilot hole in the rear face of the door, **8** drill through the holes indicated opposite, using a 2.5mm diameter drill.

Turn the door **8** over and open out the 2.5mm holes that you have just drilled by drilling back through them with a 5mm drill.

Note: Drill bits are not provided.

PESARO DOOR ONLY

Carefully choose which 2 holes you will need to drill

Drill these 2 holes if you have fitted the hinges to the left side.

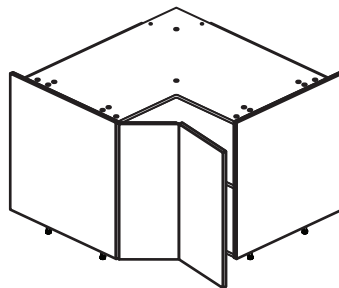

ONLY drill these 2 holes

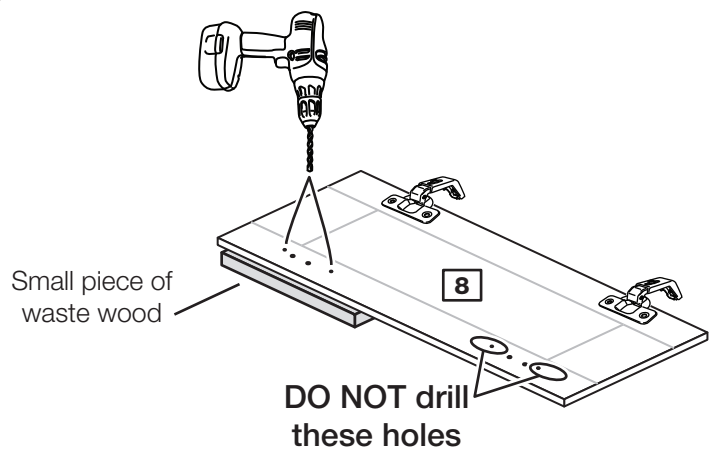

or

Drill these 2 holes if you have fitted the hinges to the right side.

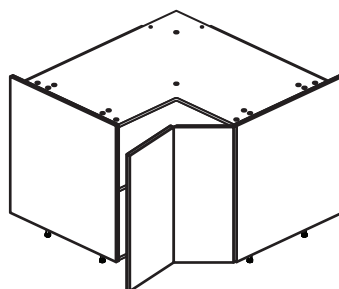

ONLY drill these 2 holes

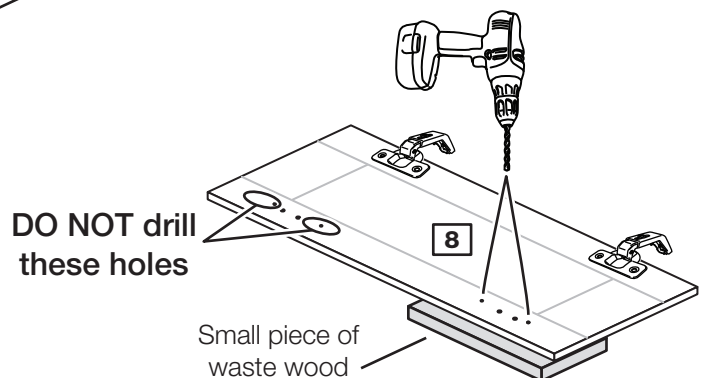

Assembly Instructions

Step 22

Drill the handle hole in the door

Important: Please follow these instructions carefully.

Lay the hinged door **9** down onto a smooth surface.

Important: Carefully choose which hole you need to drill. This will depend on which side **1** or **2** you fitted the hinge plates **N**.

Check that the holes and hinges are in the same place as the diagrams.

Note: We recommend the use of a small piece of waste wood, placed behind the hole while drilling, to reduce the possibility of any breakout.

Using the pilot hole in the rear face of the door, **9** drill through the hole indicated opposite, using a 2.5mm diameter drill.

Turn the door **9** over and open out the 2.5mm hole that you have just drilled by drilling back through it with a 5mm drill.

Note: Drill bits are not provided.

Push hole plugs **Rc** into the 2 unused hinge holes.

RICADI DOOR ONLY Carefully choose which hole you will need to drill

Drill these 2 holes if you have fitted the hinges to the left side.

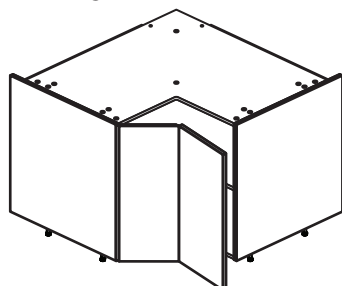

ONLY drill these 2 holes

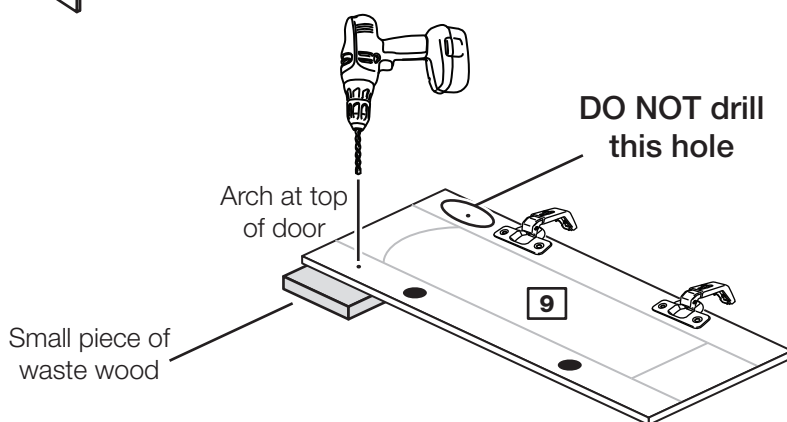

or

Drill these 2 holes if you have fitted the hinges to the right side.

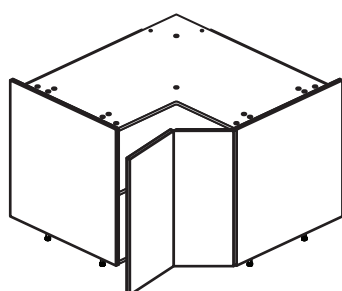

ONLY drill these 2 holes

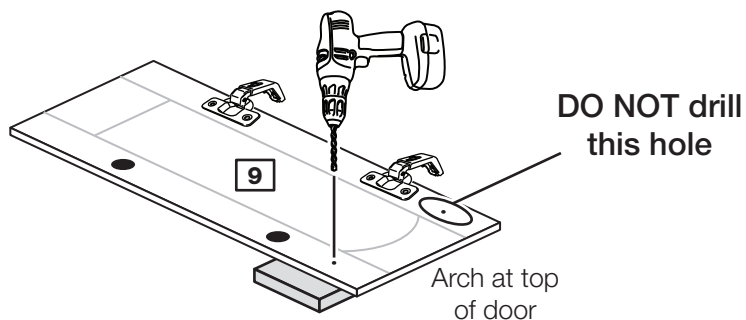

Assembly Instructions

Step 23

Fit the carcass door

2 people are needed here

Note: The easiest way to attach the carcass door **8** or **10** is to fit the top hinge first, then align and fit the other hinge.

a: Push the hooks on the cantilevered hinge arm **P** underneath the front of the hinge plate **Q**.

b: Press the front of the hinge arm **P** against the hinge plate **Q** until it clicks into place.

c: If you need to separate the hinge arm **P** from the hinge plate, **Q** press the button at the end of the hinge arm and lift it off of the hinge plate.

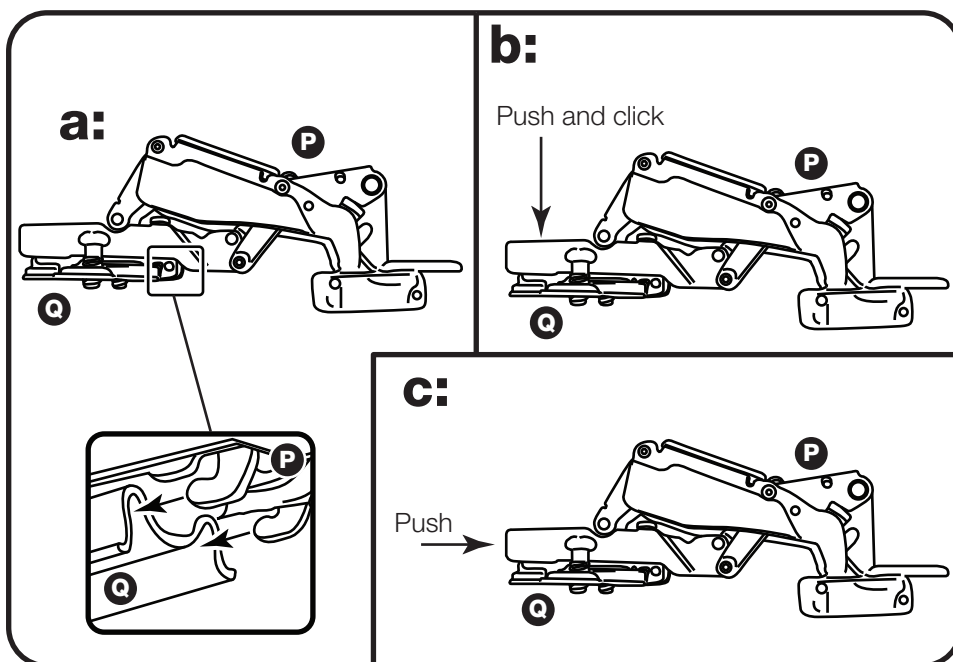

This Diagram shows a monza door being fitted.
You may have chosen different doors.

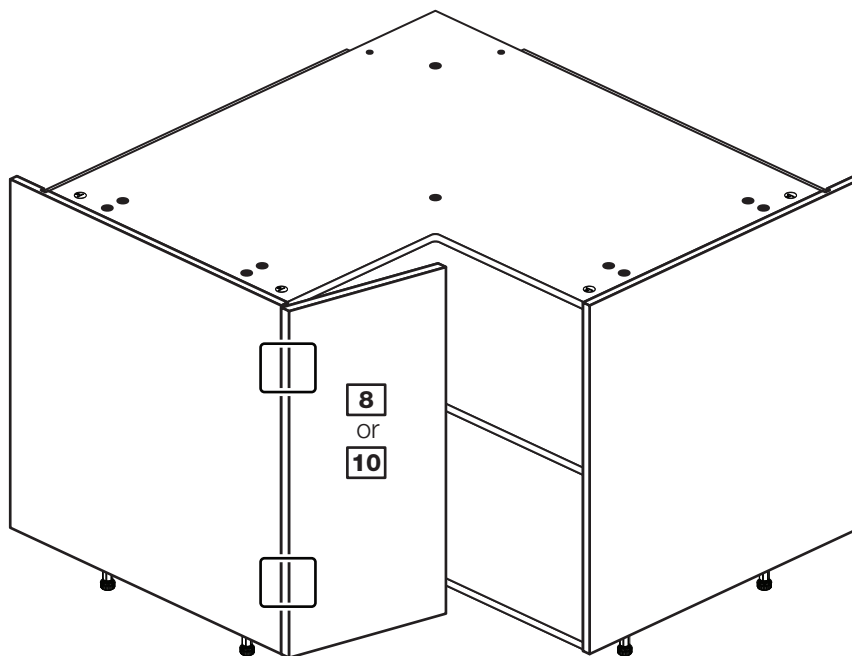

This shows the carcass door being fitted to hinge plates on the left side.
You may have fitted them to the right side.

Assembly Instructions

Step 24

Fit the carcase door

2 people are needed here

Note: The easiest way to attach the hinged door **8** or **9** is to fit the top hinge first, then align and fit the other hinge.

a: Push the hooks on the bent hinge arm **O** underneath the front of the hinge plate **N**.

b: Press the front of the hinge arm **O** against the hinge plate **N** until it clicks into place.

c: If you need to separate the hinge arm **O** from the hinge plate, **N** press the button at the end of the hinge arm and lift it off of the hinge plate.

d: Attach the handle **R a** supplied with the door **8** using the screw(s) **R b** packed with it.

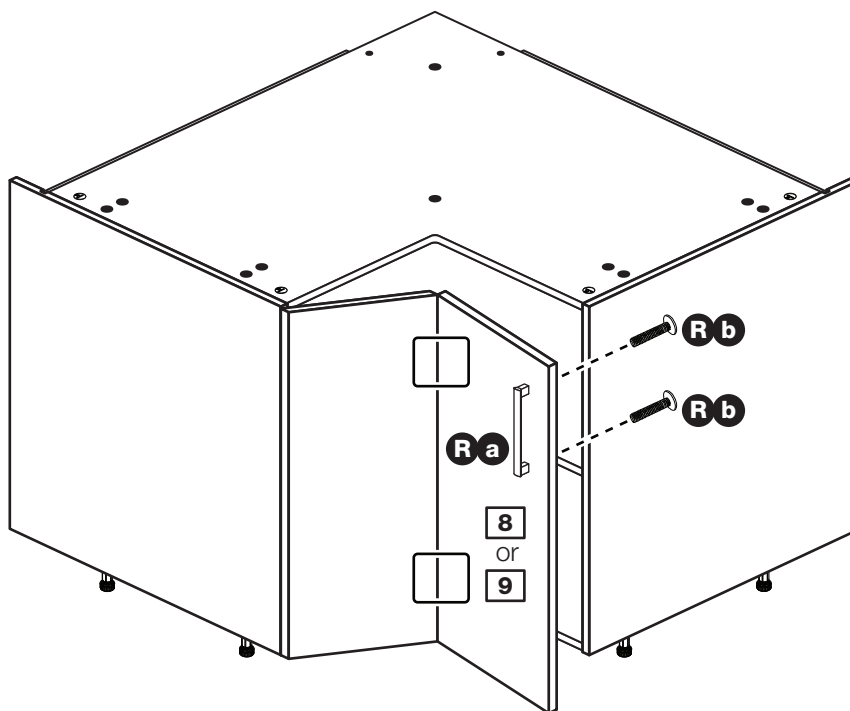
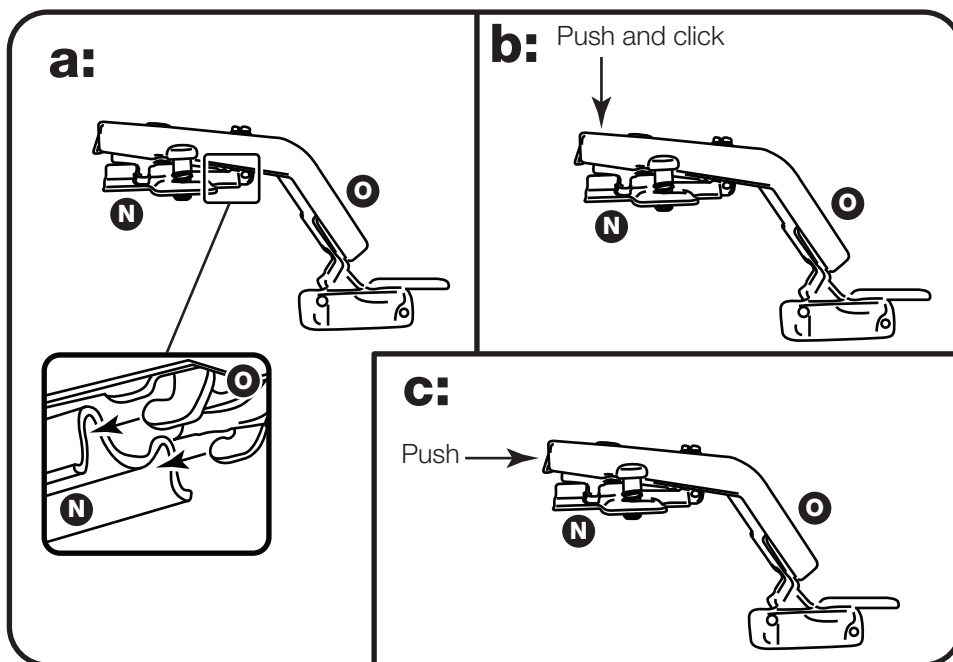

Assembly Instructions

Step 25

Fit the soft close unit

Push a soft close unit **K** onto each cantilevered hinge arm **P** until it clicks into place.

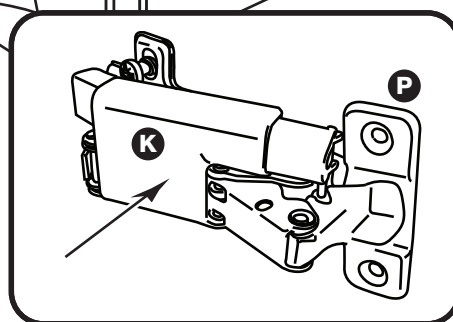
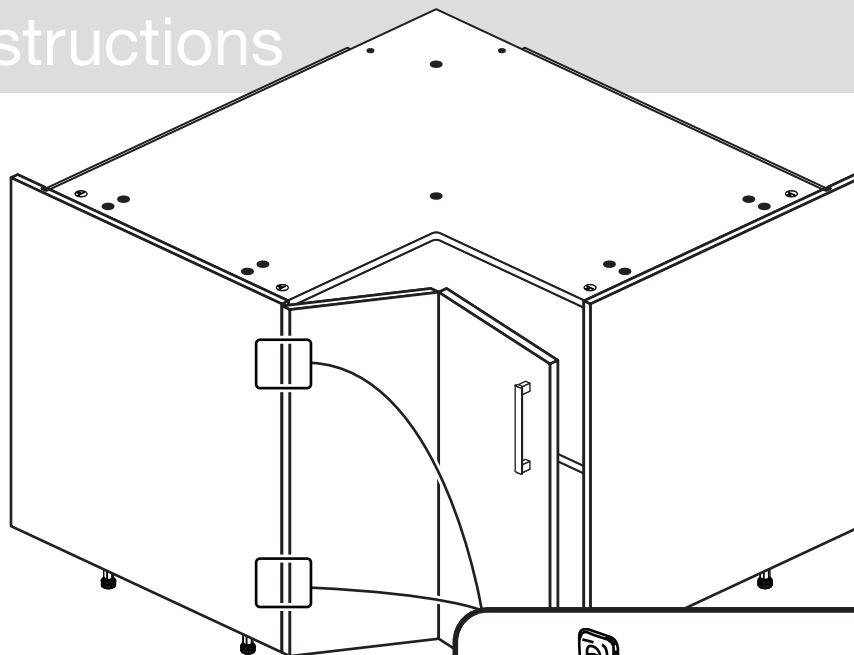

Step 26

Joining units together

Fittings have been supplied so you are able to join units together.

Make sure that your first unit is level.

Push the other unit up against first unit and ensure both units are level.

Check that the ends are flush and in line, then clamp them together.

Using a 5mm drill bit, drill 2 holes (approximate positions shown circled) in the side panel into the adjoining side panel of the other unit.

Push the connecting sleeves **G** into the holes and then screw the connecting bolts **H** in from the other side.

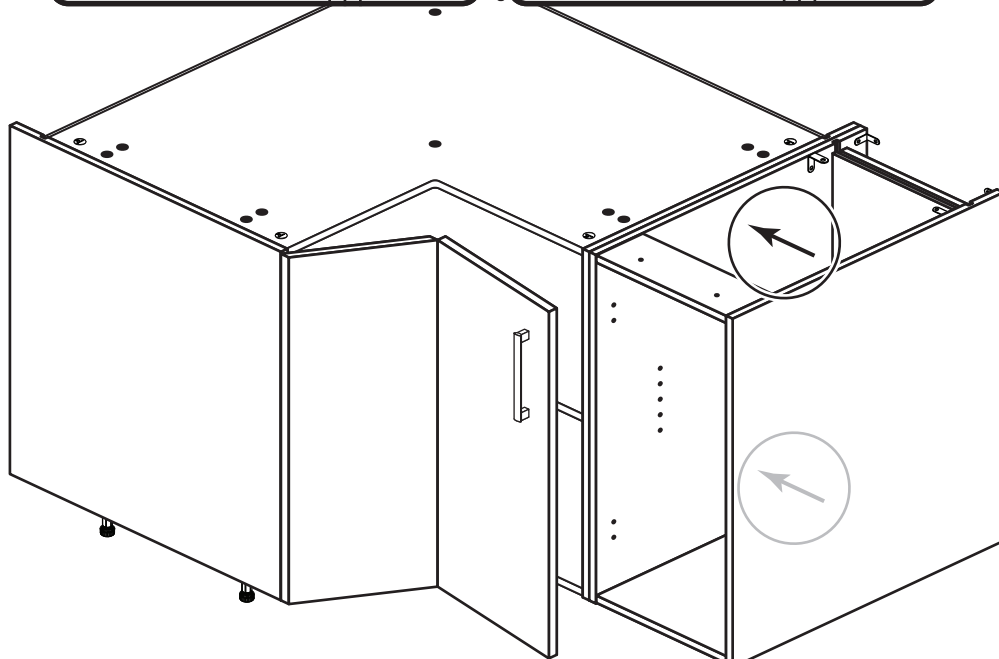
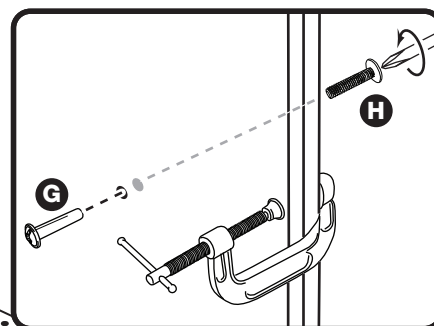
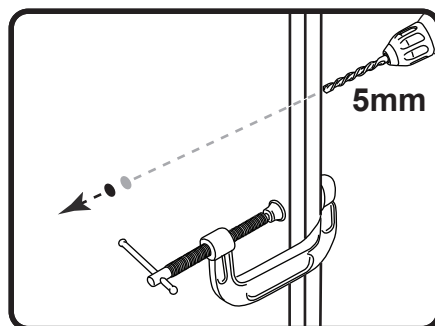

Assembly Instructions

Step 27

Adjust the doors if needed

Adjust the hinge plates and arms by turning the screws on them clockwise or anti-clockwise.

Assembly is complete



Warning: The unit is heavy. Lift with care.

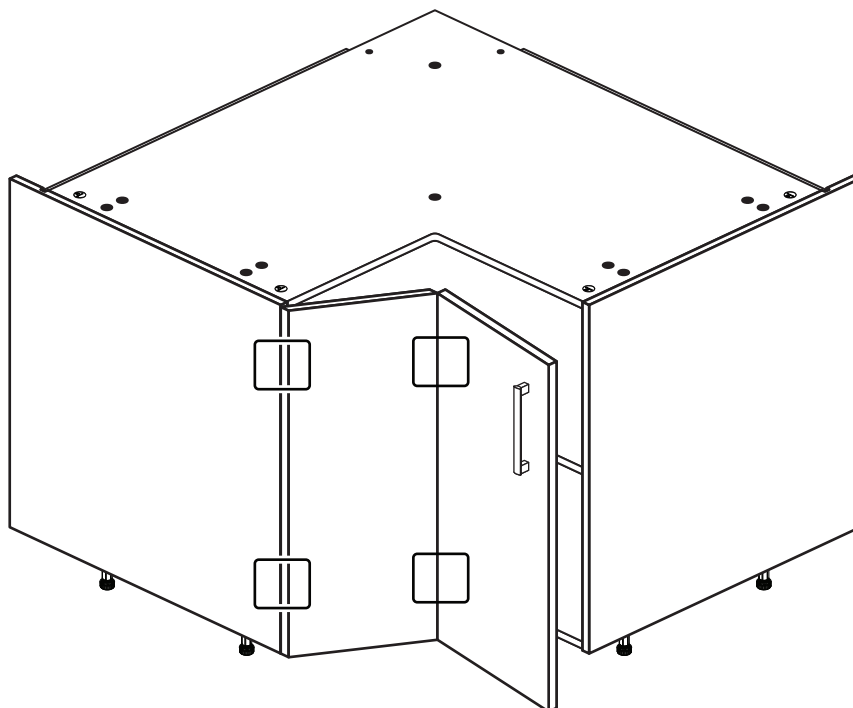

Step 28

Fit the plinth

Offer the plinth up to the unit and, using a pencil, mark the position of the unit's legs **I b** on the back of the plinth.

Position the leg bracket **I c** so it is in the centre of the pencil mark and half way up the plinth.

Fix the leg bracket **I c** to the back of the plinth using 2 screws **I e**.

Slide the leg clip **I d** into the leg bracket **I c**.

Offer the plinth up to the unit and push the leg clips **I d** onto the legs **I b**.

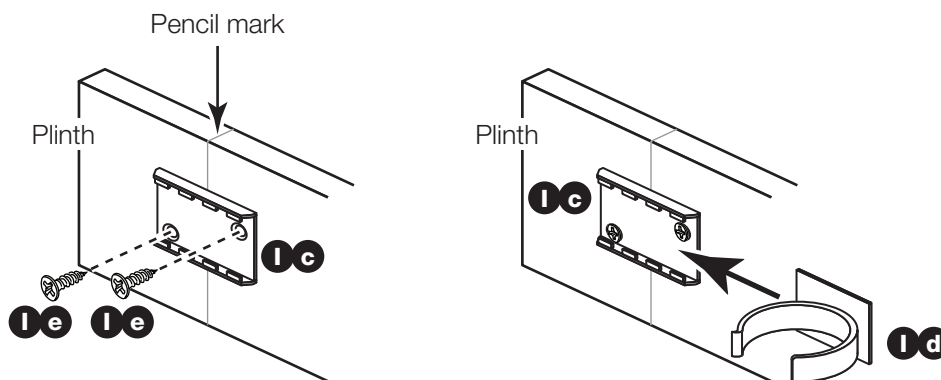

If you need help or have damaged or missing parts, call the Customer Helpline: 08456 400800 and quote the reference numbers on the component pages.

Argos Ltd, 489-499 Avebury Boulevard, Central Milton Keynes, MK9 2NW

Valencia - Corner Base Cabinet

Assembly Instructions - Please keep for future reference

hygena

Cabinet	656/5800
Black Door Pack	633/2947
Cream Door Pack	633/2789
Oak Door Pack	204/5977
White Gloss Door Pack	633/2868
White HN Door Pack	205/3189

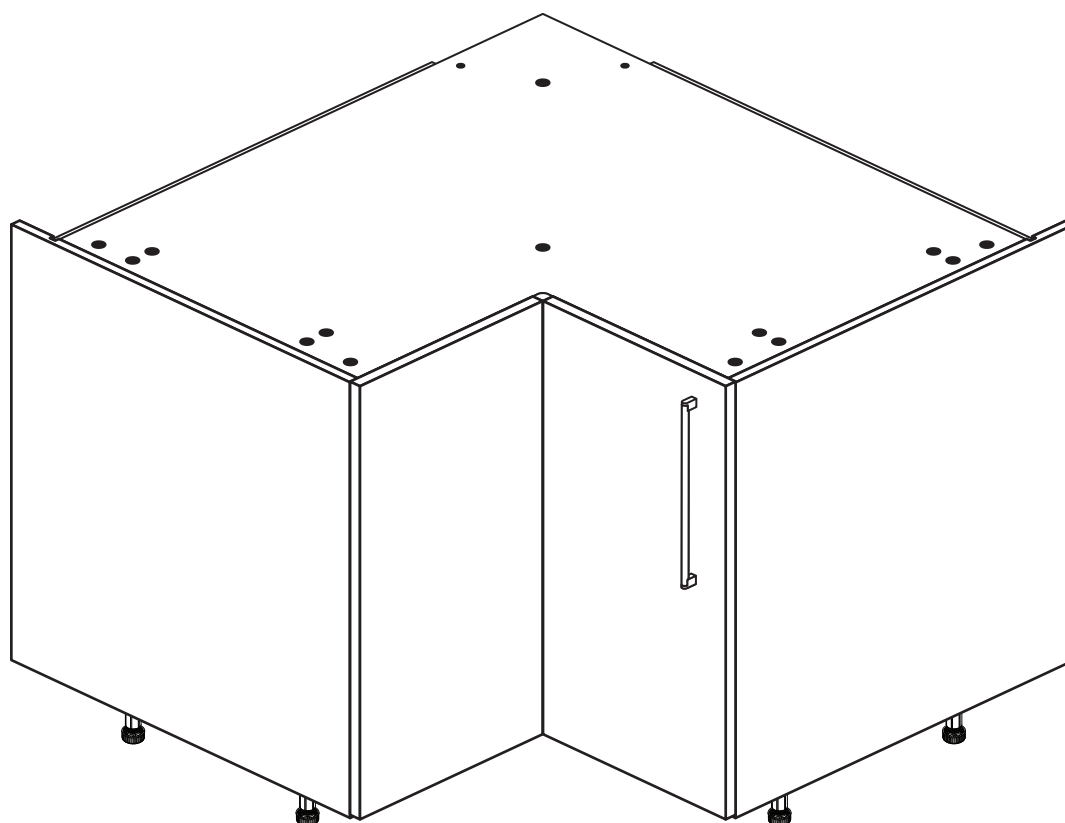

Dimensions

Width - 88cm

Depth - 88cm

Height - 87cm



**MADE IN
BRITAIN**

Important - Please read these instructions fully before starting assembly

If you need help or have damaged or missing parts, call the **Customer Helpline: 08456 400800**



Safety and Care Advice

Important - Please read these instructions fully before starting assembly

- **Warning:** This unit weighs approximately 34kgs. Please lift with care.

- Check you have all the components and tools listed on pages 2 to 5.

- Remove all fittings from the plastic bags and separate them into their groups.

- Keep children and animals away from the work area, small parts could choke if swallowed.

- Parts of the assembly will be easier with 2 people.

- Make sure you have enough space to layout the parts before starting.

- Do not stand or put weight on the product, this could cause damage.

- Assemble the item as close to its final position (in the same room) as possible.

- Assemble on a soft level surface to avoid damaging the unit or your floor (use opened out unit carton).



- We do not recommend the use of power drill/drivers **for inserting screws**, as this could damage the unit. Only use hand screwdrivers.

- **Safety note:** If there is any chance of this unit being pulled over by children etc. it is recommended that the unit is secured to a wall using suitable fixings (not supplied).

- Dispose of all packaging carefully and responsibly.

Care and maintenance

- Only clean using a damp cloth and mild detergent, do not use bleach or abrasive cleaners.

- From time to time check that there are no loose screws on this unit.

- This product should not be discarded with household waste. Take to your local authority waste disposal centre.

Note: If required the next page can be cut out and used as reference throughout the assembly. Keep this page with these instructions for future reference.

Components - Panels

If you have damaged or missing components, call the **Customer Helpline: 08456 400800** quoting the reference numbers below

Please check you have all the panels listed below

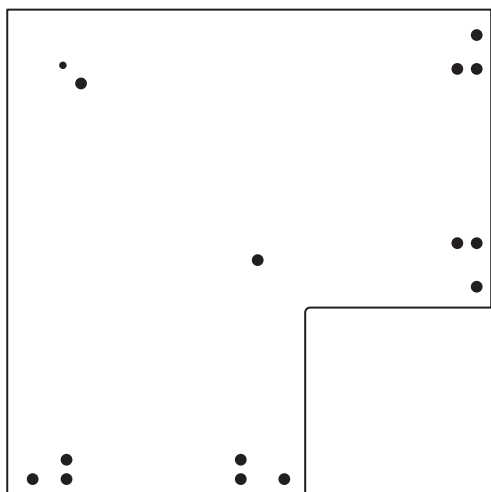

1 Top/Base (DPF136A)
(800 x 800mm) x 2

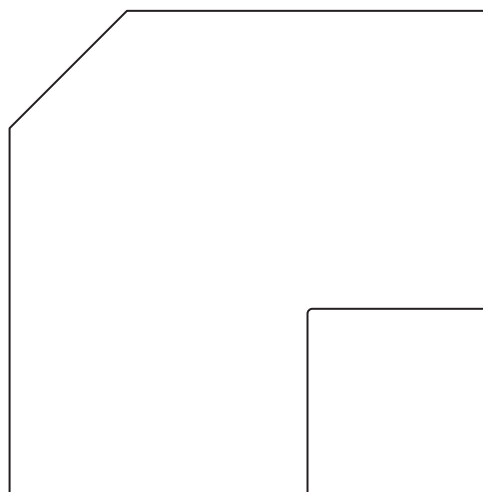

2 Loose Shelf (DPF137A)
(798 x 798mm)

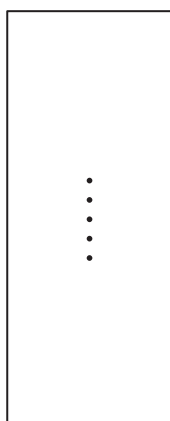

3 Back (DPF138A)
(272 x 688mm)

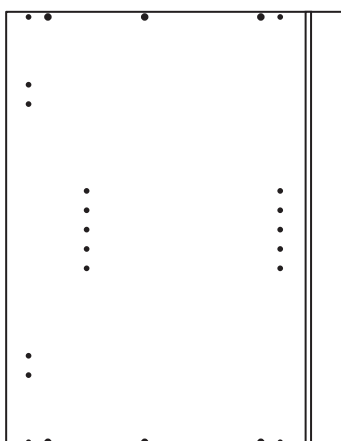

4 Left/Right Side (DPF177A)
(720 x 560mm) x 2

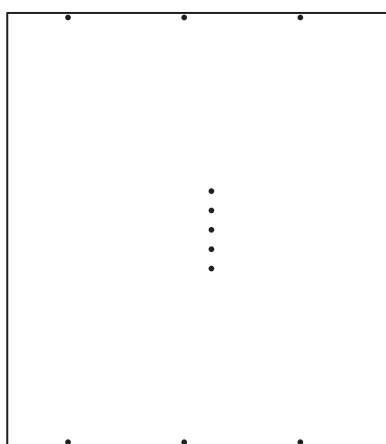

5 Left/Right Back (DPF139A)
(630 x 717mm) x 2

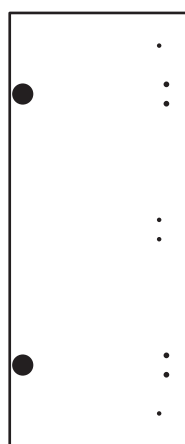

6 Door (DPF145B)
(297 x 716mm) x 2

The front surface of this door is protected with a peel-off film











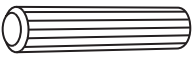
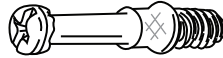

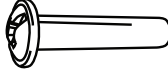

Components - Fittings

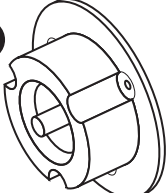
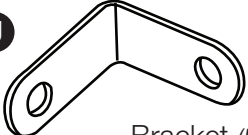
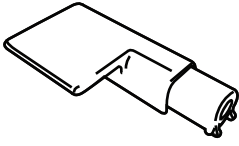
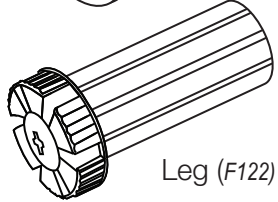
If you have damaged or missing components, call the
Customer Helpline: 08456 400800 quoting the reference
 numbers below

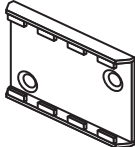
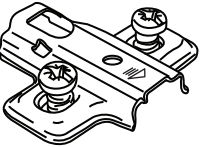
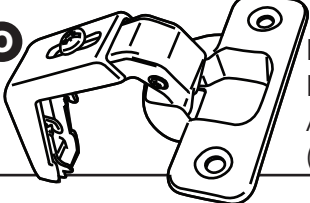
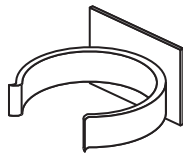
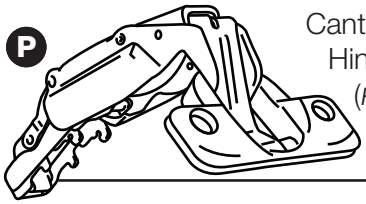
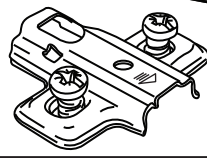
Please check you have all the fittings listed below

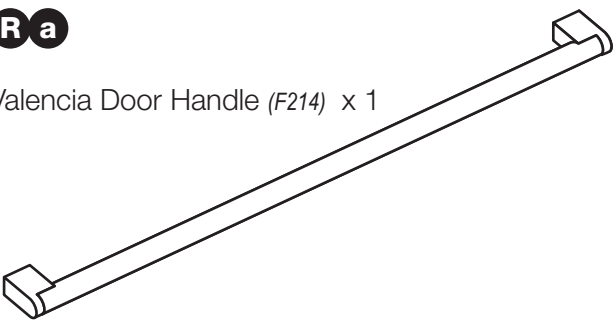
Note: The quantities below are the correct amount to complete the assembly. In some cases more fittings may be supplied than are required.

<p>A </p> <p>Wooden dowel (F22) x 16</p>	<p>B </p> <p>Metal dowel (F901) x 8</p>	<p>C </p> <p>Large locking nut (F900) x 8</p>
<p>D </p> <p>13mm Screw (F63) x 8</p>	<p>E </p> <p>13mm Screw (F79) x 2</p>	<p>F </p> <p>25mm Screw (F50) x 18</p>
<p>G </p> <p>Connecting Sleeve (F432) x 2</p>	<p>H </p> <p>19mm Connecting bolt (F461) x 2</p>	<p>l a </p> <p>Leg Socket (F120) x 6</p>
<p>J </p> <p>Bracket (F945) x 2</p>	<p>K </p> <p>Soft Close Unit (F156) x 2</p>	<p>l b </p> <p>Leg (F122) x 6</p>
<p>L </p> <p>40mm Screw (F910) x 2</p>	<p>M </p> <p>Shelf support (F110) x 7</p>	<p>l c </p> <p>Leg Bracket (F127) x 3</p>
<p>N </p> <p>2mm Hinge Plate (F157) x 2</p>	<p>O </p> <p>Bent Hinge Arm (F154) x 2</p>	<p>l d </p> <p>Leg Clip (F128) x 3</p>
<p>P </p> <p>Cantilevered Hinge Arm (F155) x 2</p>	<p>Q </p> <p>4mm Hinge Plate (F158) x 2</p>	<p>l e </p> <p>16mm Screw (F129) x 24</p>
<p>R a </p> <p>Valencia Door Handle (F214) x 1</p>		<p>R b </p> <p>25mm Screw (F132) x 2</p>

Assembly Instructions

If you have damaged or missing components, call the
Customer Helpline: 08456 400800 quoting the reference
numbers below

Step 1

Choose which way you would like the door to open

You can fit the door to the left side or right side.

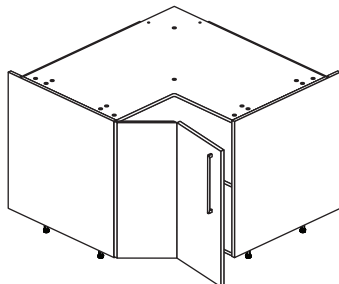

If you would like your door to open this way, fit the hinge plates to the left side

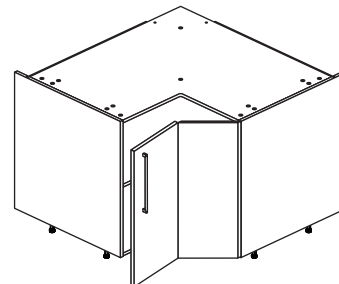

If you would like your door to open this way, fit the hinge plates to the right side

Step 2

Prepare the left side

Refer to step 1 and, if required, fit 2 hinge plates **Q** onto the left side **4**, making sure that they face the same way as the diagram.

Screw 4 metal dowels **B** into the holes shown on the left side **4**.

Note: Tighten metal dowels up fully against the panels.

Fit a bracket **J** flush to the top and back edge of the left side **4**.

Secure the bracket **J** using screw **E**.

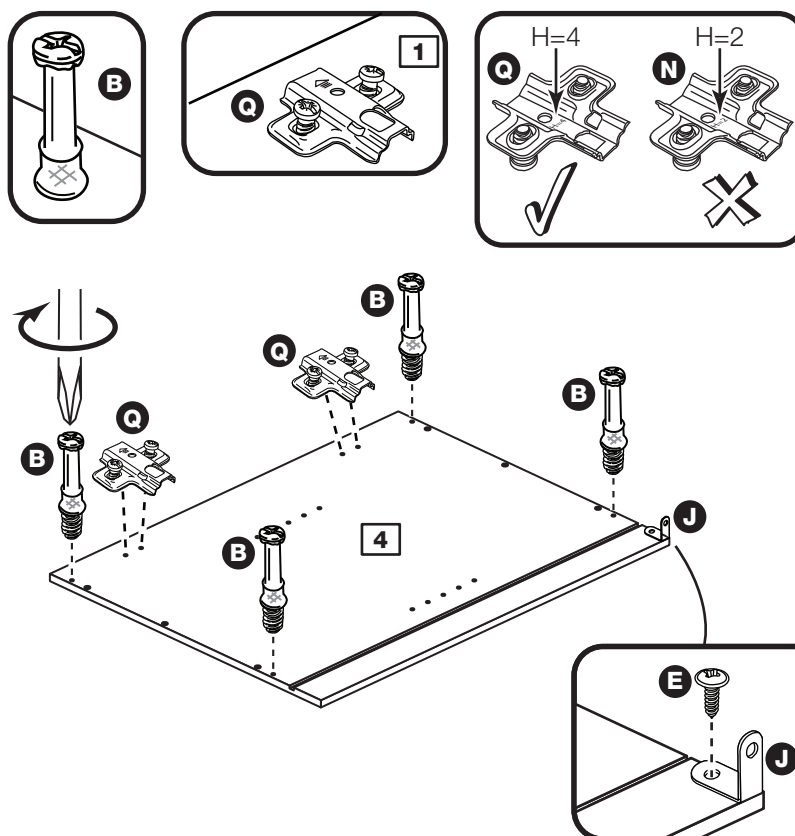

Assembly Instructions

Step 3

Prepare the right side

Refer to step 1 and, if required, fit 2 hinge plates **Q** onto the right side **4**, making sure that they face the same way as the diagram.

Screw 4 metal dowels **B** into the holes shown on the right side **4**.

Note: Tighten metal dowels up fully against the panels.

Fit a bracket **J** flush to the top and back edge of the right side **4**.

Secure the bracket **J** using screw **E**.

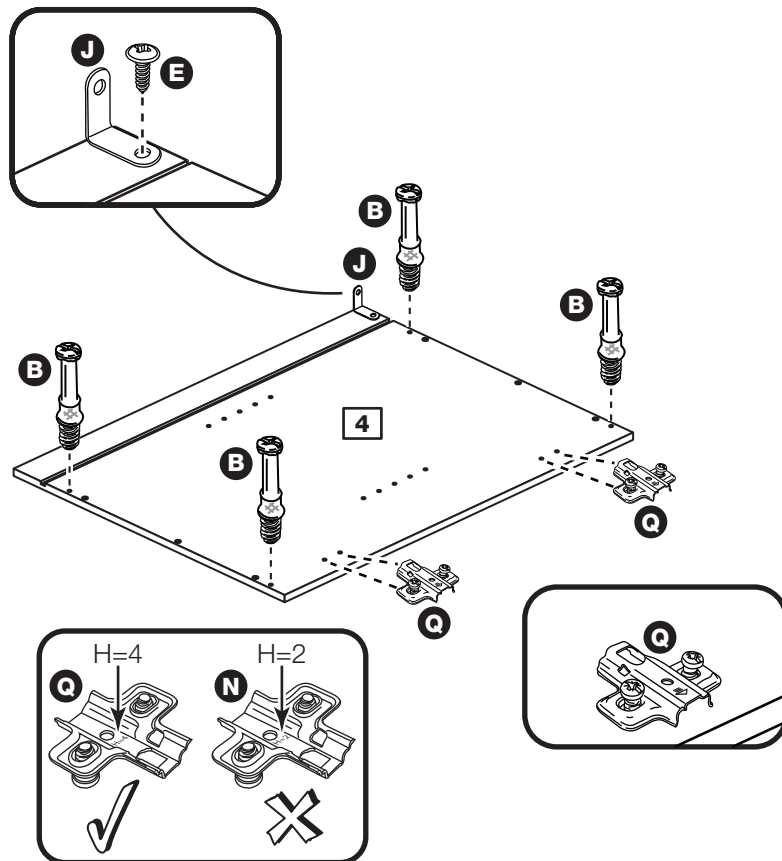

Step 4

Prepare the top and base

Insert 4 large locking nuts **C** into the top **1** and base **1** as shown.

Note: Arrow on locking nut **must** point towards hole in edge of panel.

Tap 6 wooden dowels **A** into the top **1** and base **1** as shown.

Note: Wooden dowels **must not** stick out from the edge by more than 10mm or they may damage other panels.

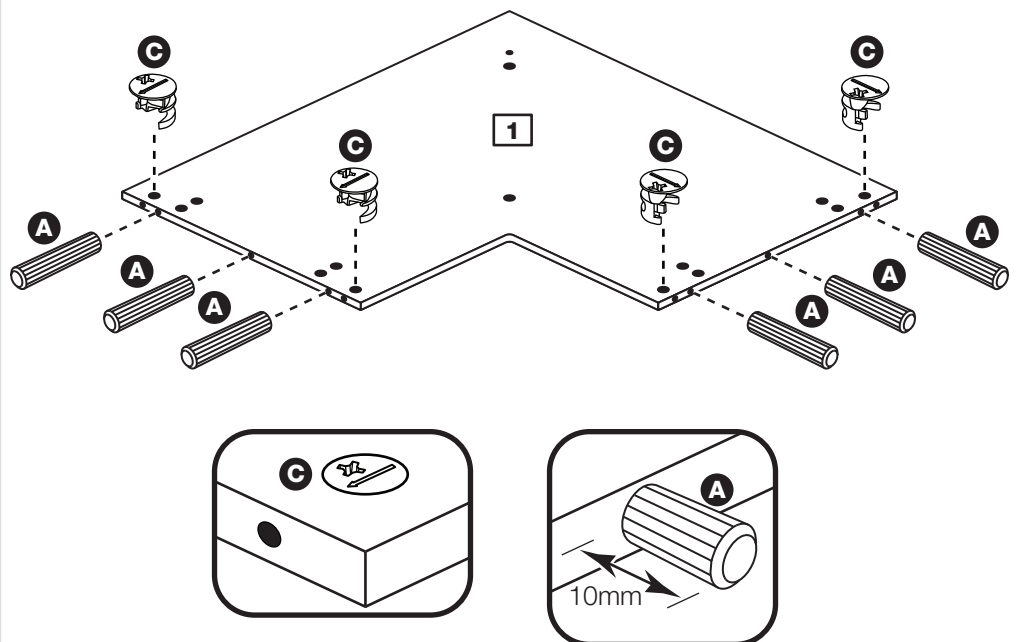

Assembly Instructions

Step 5

Fit the legs to the base

a: Push the leg sockets **1a** into the holes in the base **1** as shown.

b: Secure each leg socket **1a** with 3 screws **1e**.

c: Tap in the centre plug on each leg socket **1a**.

d: Push the leg **1b** into the leg socket **1a**.

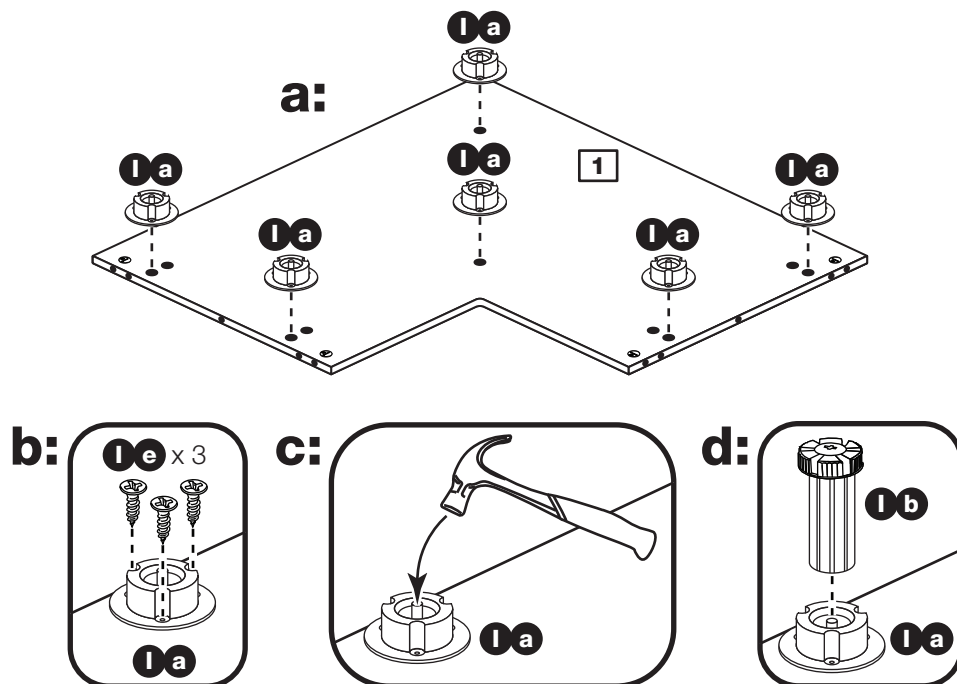

Step 6

Join the right side and base

Push the base **1** onto the right side **4**.

Use a screwdriver to tighten the 2 large locking nuts **C** fitted to the base **1**.

Note: Turn the large locking nuts **C** as far as they will go - more than 1/2 a turn.

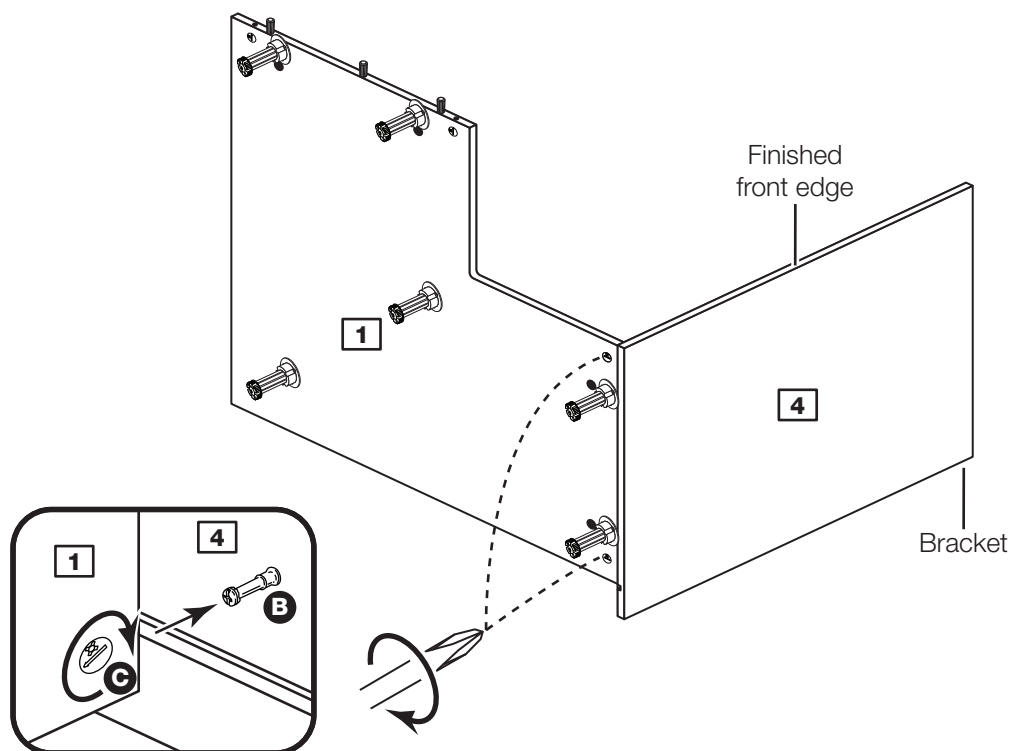

Assembly Instructions

Step 7

Prepare the back

Tap 4 wooden dowels **A** into the back **3** as shown.

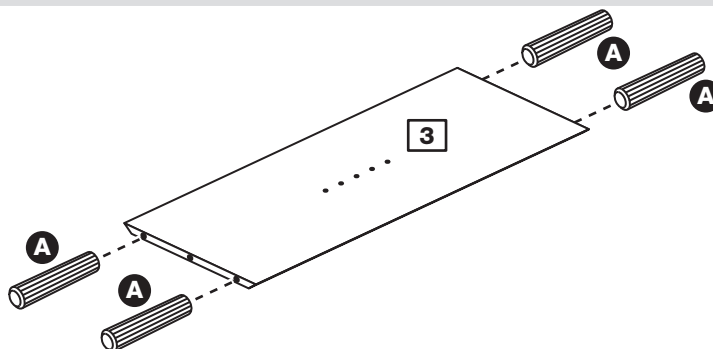

Step 8

Fit the back

Push the back **3** onto the base **1** and secure with screw **L**.

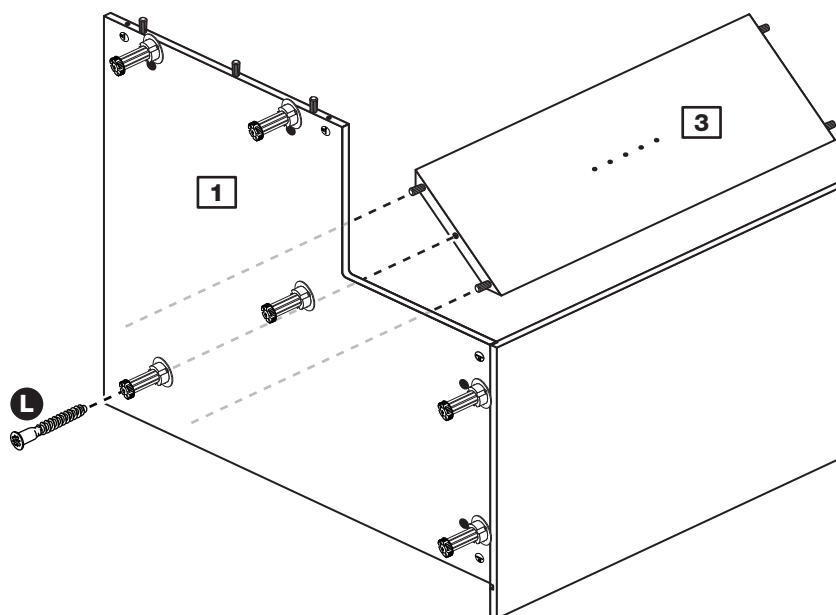

Step 9

Fit the top

Push the top **1** onto the right side **4** and back **3**.

Use a screwdriver to tighten the 2 large locking nuts **C** fitted to the top **1**.

Note: Turn the large locking nuts **C** as far as they will go - more than 1/2 a turn.

Secure the back **3** to the top **1** with screw **L**.

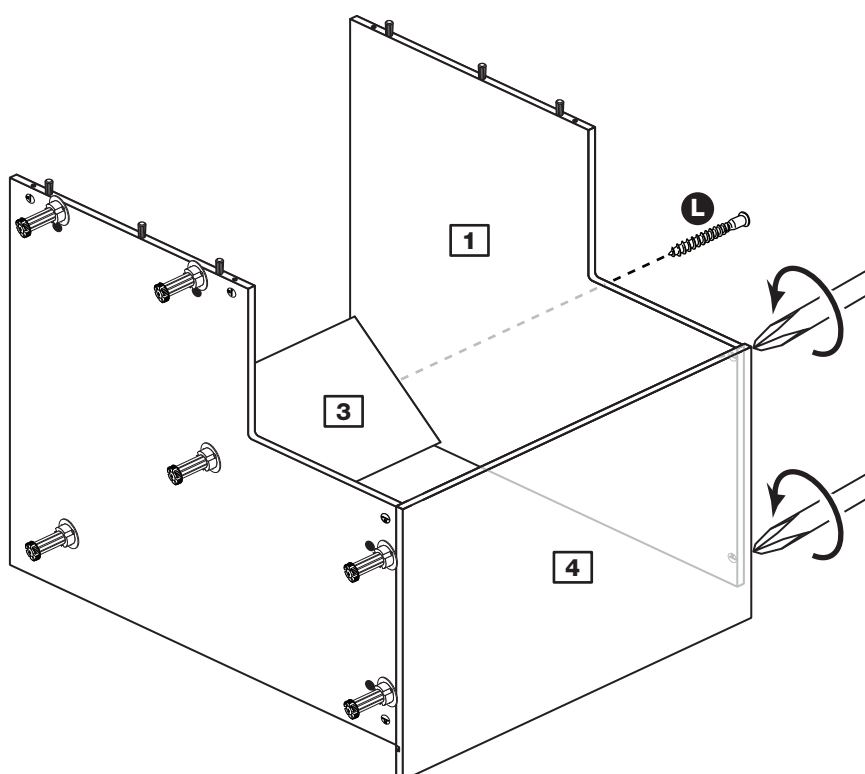

Assembly Instructions

Step 10

Insert the loose shelf

Place the loose shelf **2** inside the unit.

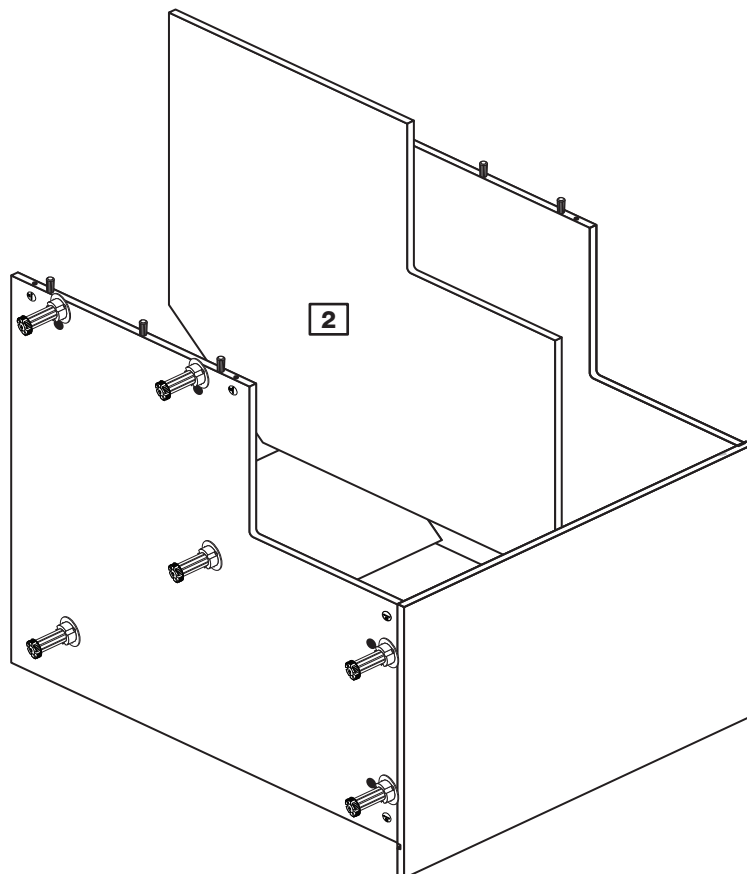

Step 11

Fit the left side

Push the left side **4** onto the base **1** and top **1**.

Use a screwdriver to tighten the 4 large locking nuts **C** fitted to the base **1** and top **1**.

Note: Turn the large locking nuts **C** as far as they will go - more than 1/2 a turn.

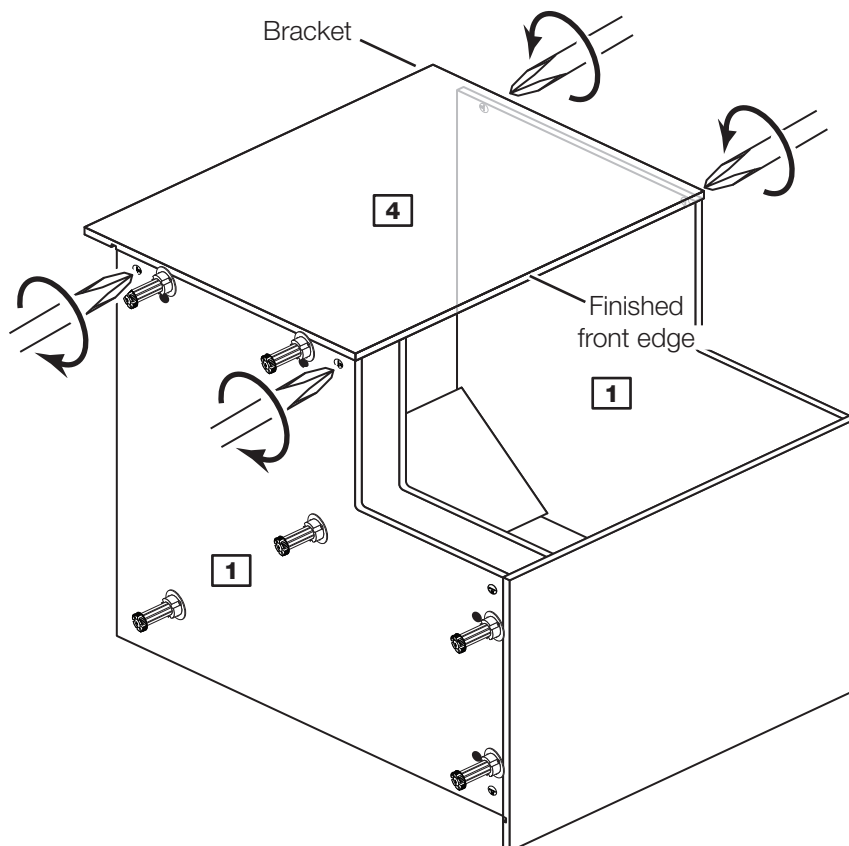

Assembly Instructions

Step 12

Fit the left back

Slide the left back **5** along the groove in the left side.

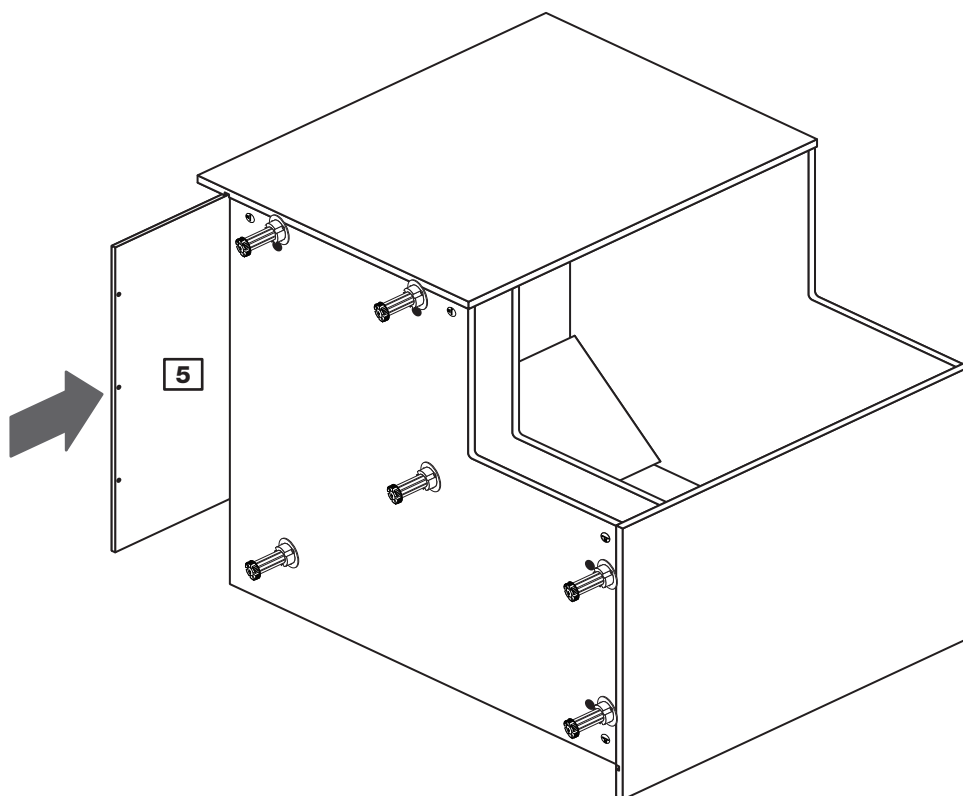

Step 13

Secure the left back

Secure the left back **5** with 6 screws **F** through its pre-drilled holes into the base and top.

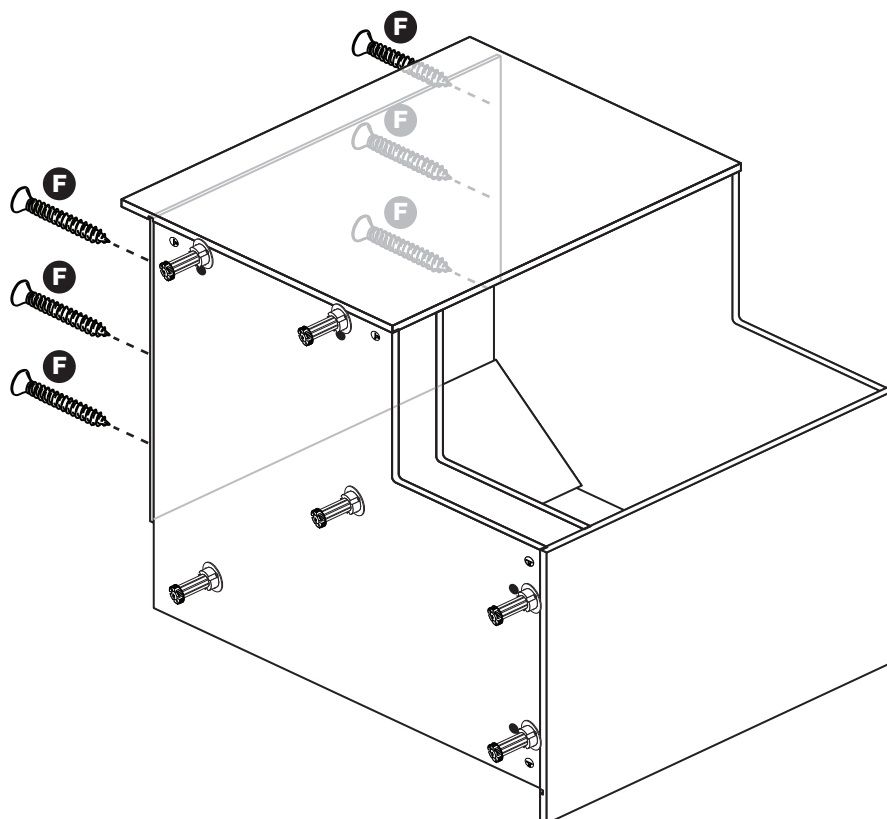

Assembly Instructions

Step 14

Fit the right back

Slide the right back **5** along the groove in the right side.

Secure the right back **5** with 6 screws **F** through its pre-drilled holes into the base and top.

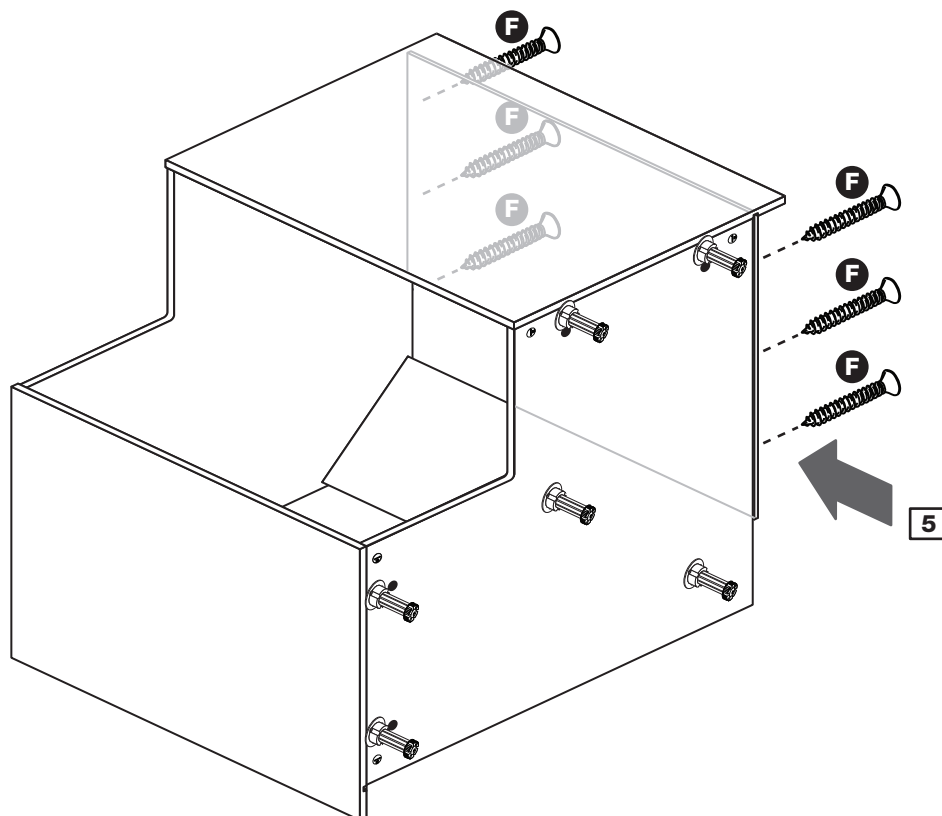

Step 15

Fit the loose shelf

Hold the loose shelf **2** up and insert 7 shelf studs **M** at the required height.

Lower the loose shelf **2** down onto the shelf studs **M**.

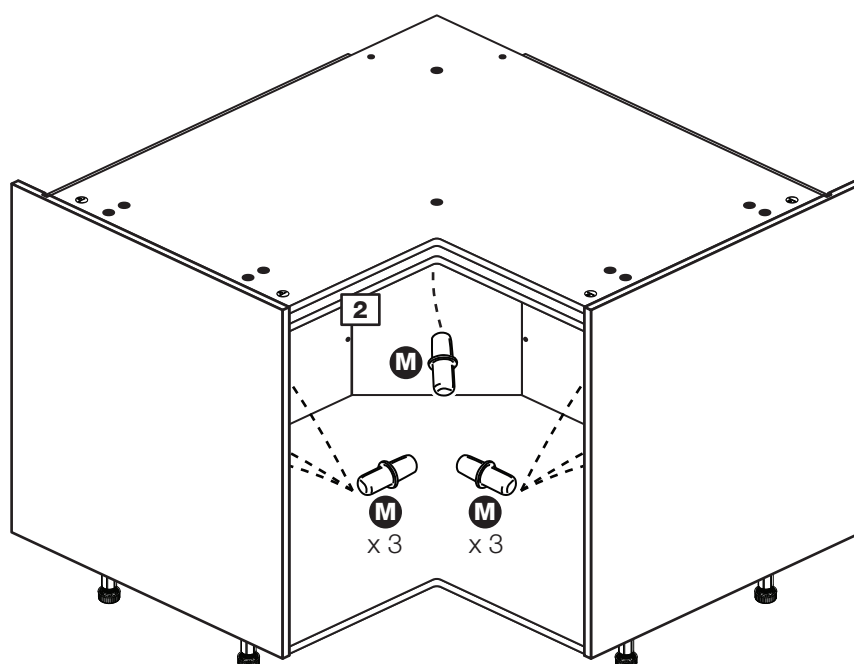

Assembly Instructions

Step 16

Prepare 1 of the doors to be the carcase door

a: Fit 2 hinge plates **N** onto a door **6**, making sure that they face the same way as the diagram.

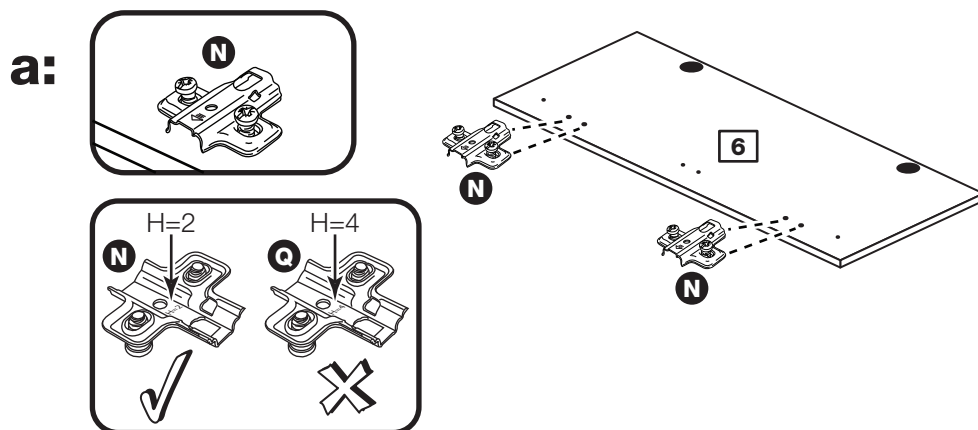

b: Push fit 2 cantilevered hinge arms **P** into the door **6**.

Secure each hinge arm with 2 screws **D**.

Note: Before securing with the screws, make sure that the hinges are positioned at 90 degrees with the front edge of the door.

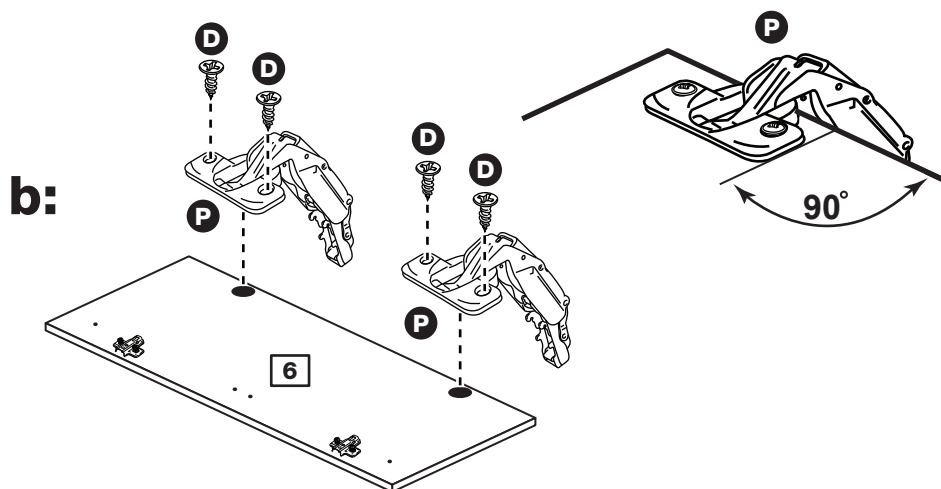

Assembly Instructions

Step 17

Fit the carcass door

2 people are needed here

Note: The easiest way to attach the carcass door **6** is to fit the top hinge first, then align and fit the other hinge.

a: Push the hooks on the cantilevered hinge arm **P** underneath the front of the hinge plate **Q**.

b: Press the front of the hinge arm **P** against the hinge plate **Q** until it clicks into place.

c: If you need to separate the hinge arm **P** from the hinge plate, **Q** press the button at the end of the hinge arm and lift it off of the hinge plate.

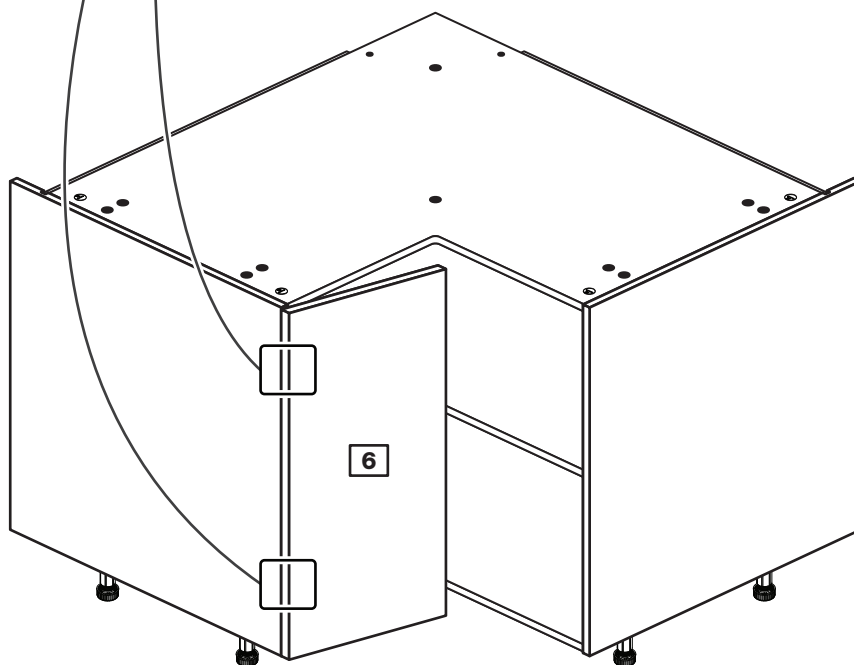
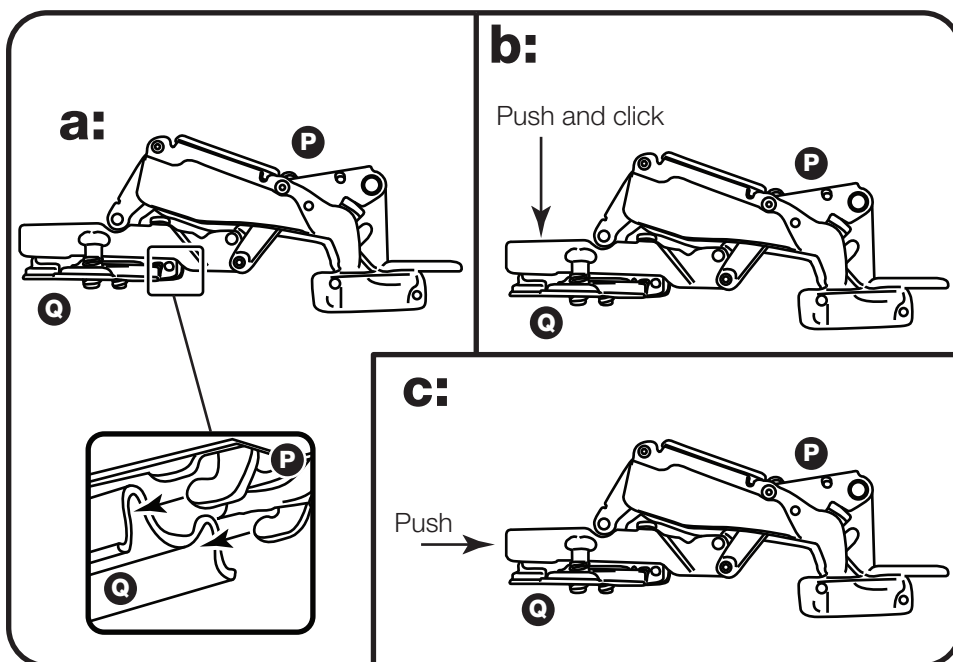

This shows the carcass door being fitted to hinge plates on the left side. You may have fitted them to the right side.

Assembly Instructions

Step 18

Prepare the other door to be the hinged door

Push fit 2 bent hinge arms **O** into the other door **6**.

Secure each hinge arm with 2 screws **D**.

Note: Before securing with the screws, make sure that the hinges are positioned at 90 degrees with the front edge of the door.

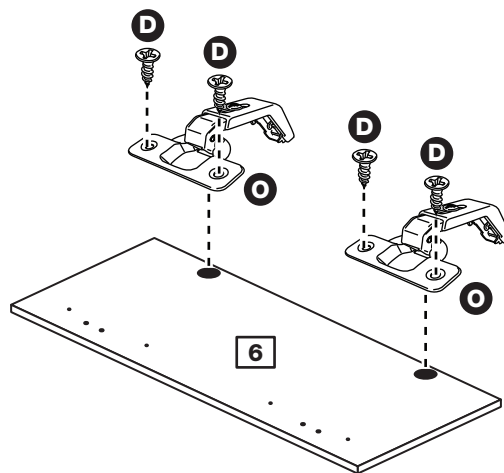
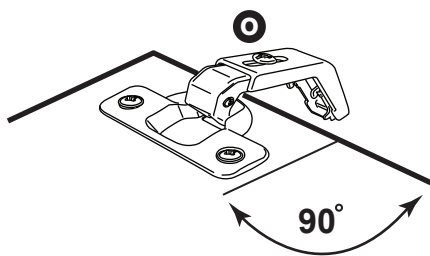

Assembly Instructions

Step 19

Drill the handle holes in the hinged door

Important: Please follow these instructions carefully.

Lay the door **6** down onto a smooth surface.

Important: Carefully choose which holes you need to drill. This will depend on which side you fitted the hinge plates **N**.

Check that the holes and hinges are in the same place as the diagrams.

Note: We recommend the use of a small piece of waste wood, placed behind the hole while drilling, to reduce the possibility of any breakout.

Using the pilot hole in the rear face of the door, **6** drill through the holes indicated opposite, using a 2.5mm diameter drill.

Turn the door **6** over and open out the 2.5mm holes that you have just drilled by drilling back through them with a 5mm drill.

Note: Drill bits are not provided.

PLEASE FOLLOW THESE INSTRUCTIONS CAREFULLY TO CHOOSE WHICH 2 HOLES YOU WILL NEED TO DRILL

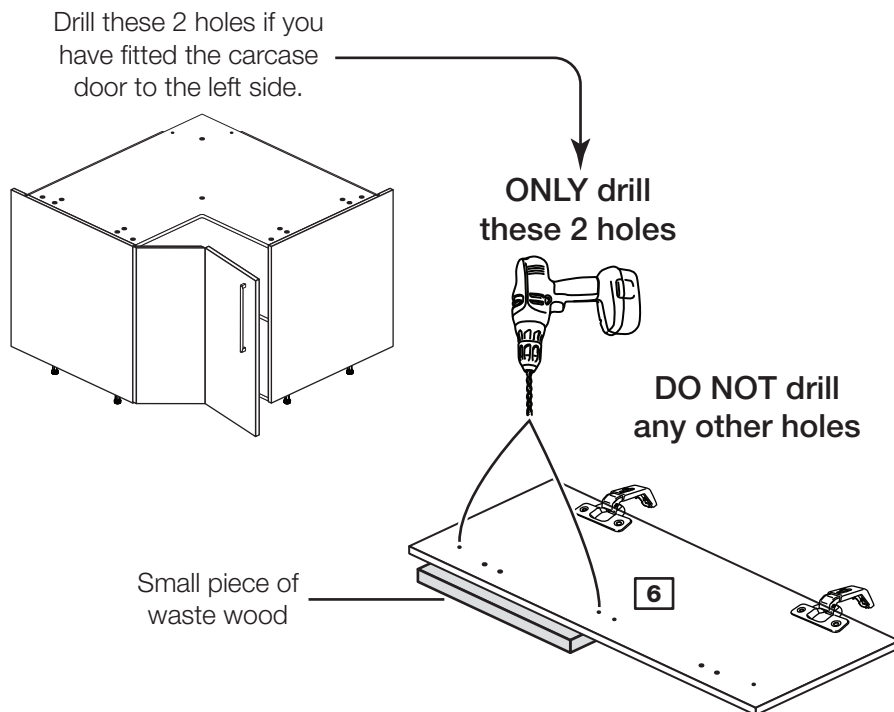

or

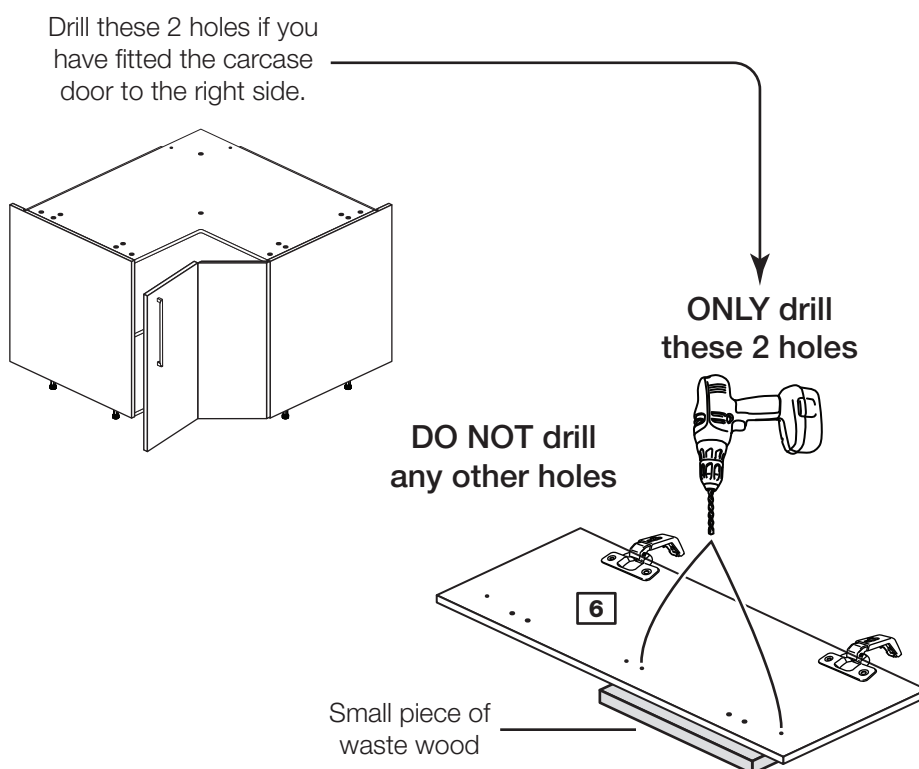

Assembly Instructions

Step 20

Fit the hinged door

2 people are needed here

Note: The easiest way to attach the hinged door **8** is to fit the top hinge first, then align and fit the other hinge.

a: Push the hooks on the bent hinge arm **O** underneath the front of the hinge plate **N**.

b: Press the front of the hinge arm **O** against the hinge plate **N** until it clicks into place.

c: If you need to separate the hinge arm **O** from the hinge plate, **N** press the button at the end of the hinge arm and lift it off of the hinge plate.

d: Attach the handle **Ra** supplied with the door **6** using the screw(s) **Rb** packed with it.

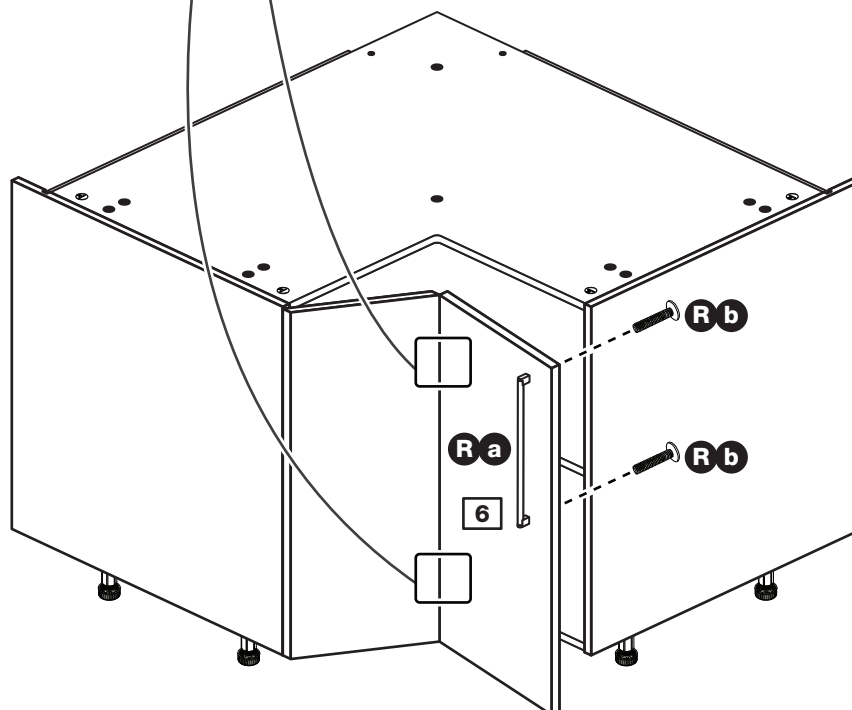
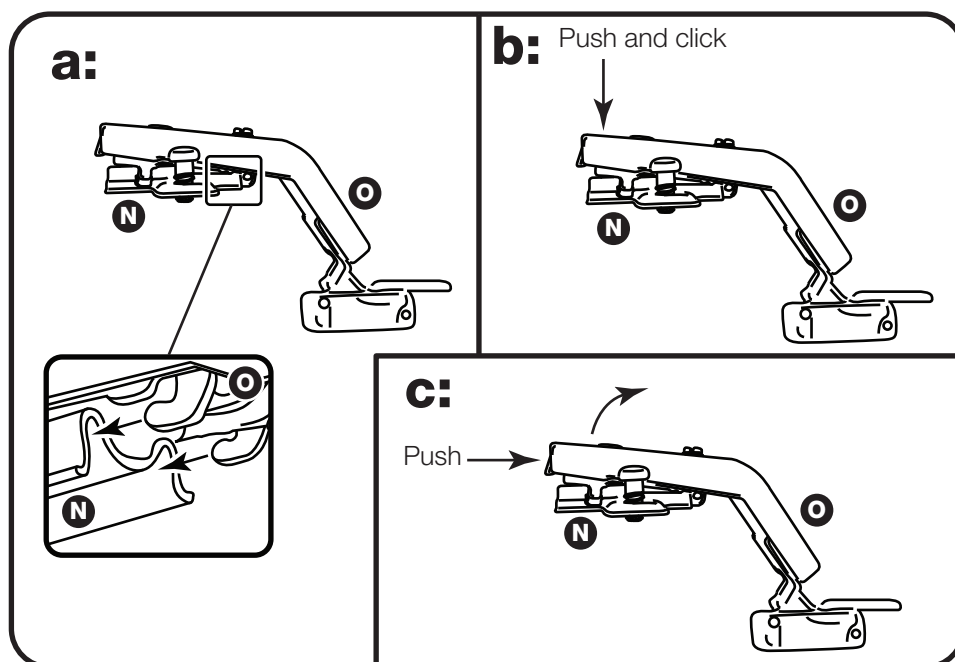

This shows the hinged door being fitted to carcass door on the left side.

You may have fitted it to the right side.

Assembly Instructions

Step 21

Fit the soft close unit

Push a soft close unit **K** onto each cantilevered hinge arm **P** until it clicks into place.

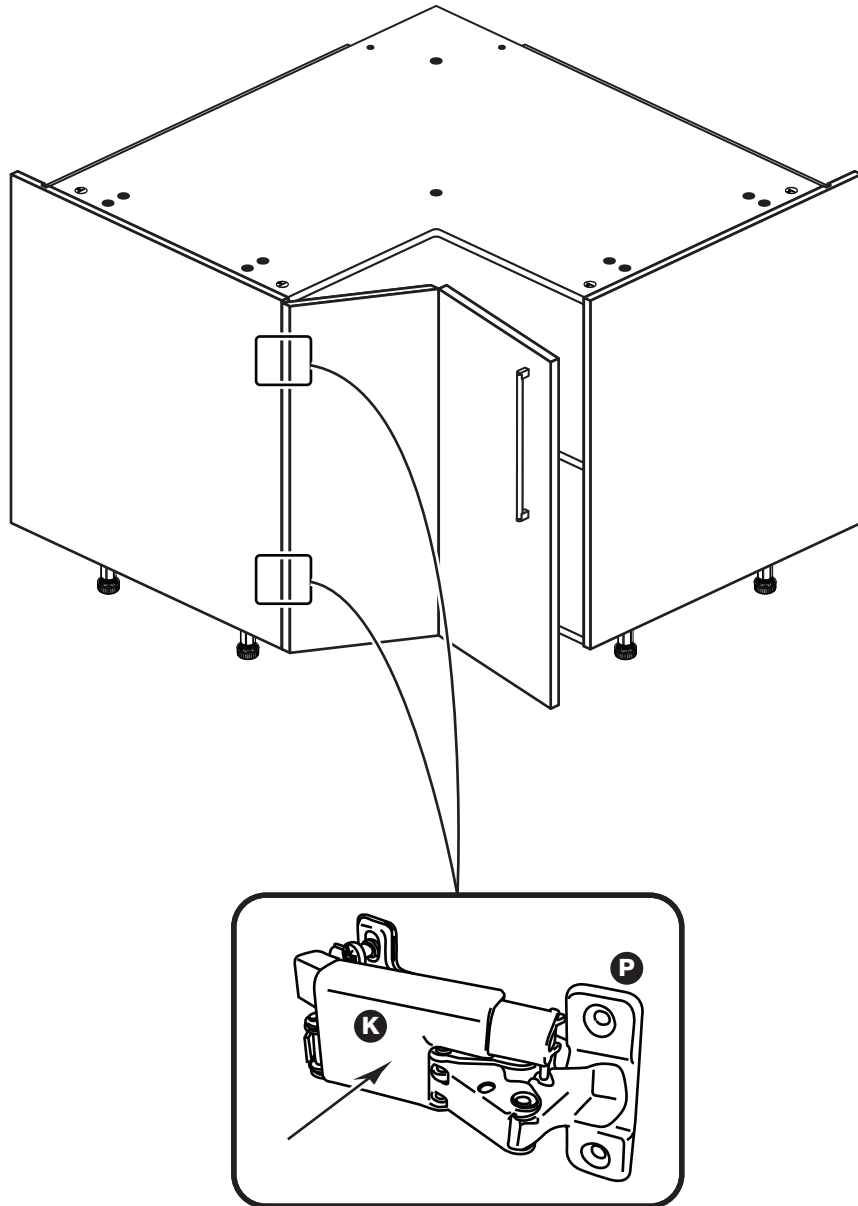

Assembly Instructions

Step 22

Joining units together

Fittings have been supplied so you are able to join units together.

Make sure that your first unit is level.

Push the other unit up against first unit and ensure both units are level.

Check that the ends are flush and in line, then clamp them together.

Using a 5mm drill bit, drill 2 holes (approximate positions shown circled) in the side panel into the adjoining side panel of the other unit.

Push the connecting sleeves **G** into the holes and then screw the connecting bolts **H** in from the other side.

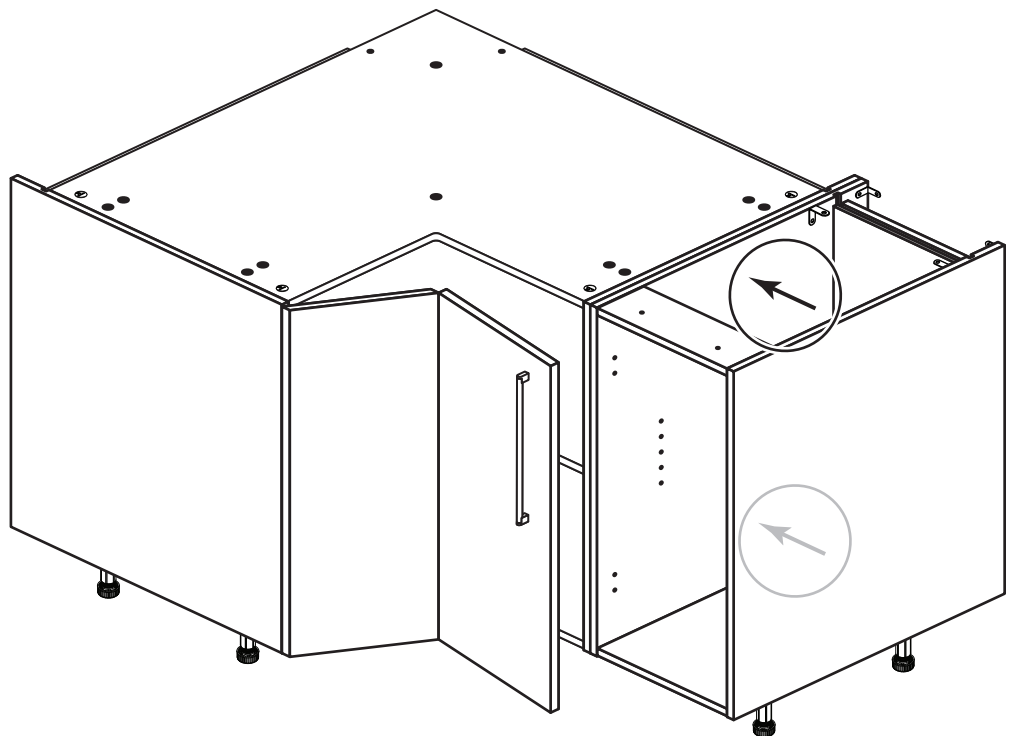
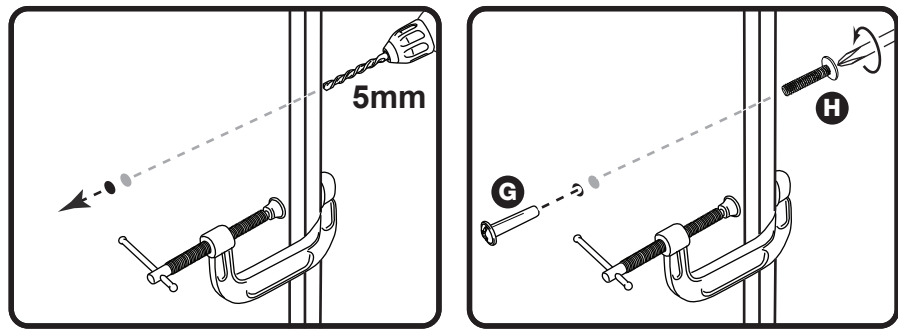

Assembly Instructions

Step 23

Adjust the doors if needed

Adjust the hinge plates and arms by turning the screws on them clockwise or anti-clockwise.

Assembly is complete



Warning: The unit is heavy. Lift with care.

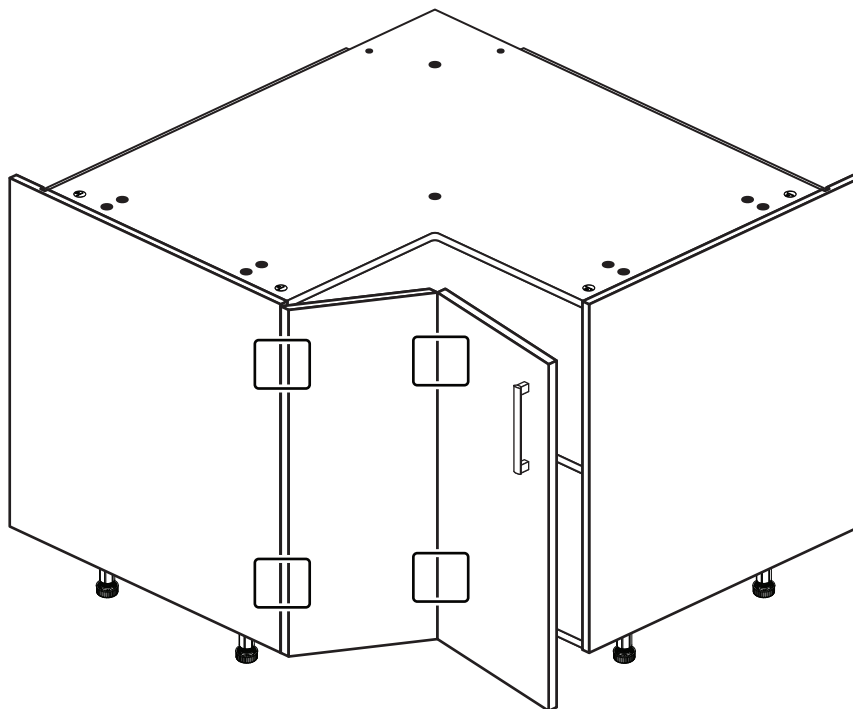

Step 24

Fit the plinth

After cutting the plinth to the required length, offer the plinth up to the unit and using a pencil, mark the position of the unit's legs **Ib** on the back of the plinth.

Position the leg bracket **Ic** so it is in the centre of the pencil mark and half way up the plinth.

Fix the leg bracket **Ic** to the back of the plinth using 2 screws **Ie**.

Slide the leg clip **Id** into the leg bracket **Ic**.

Offer the plinth up to the unit and push the leg clips **Id** onto the legs **Ib**.

Black Plinth Pack	608/2345
Cream Plinth Pack	608/2369
Oak Plinth Pack	205/5668
White Gloss Plinth Pack	608/2352
White HN Plinth Pack	198/9917

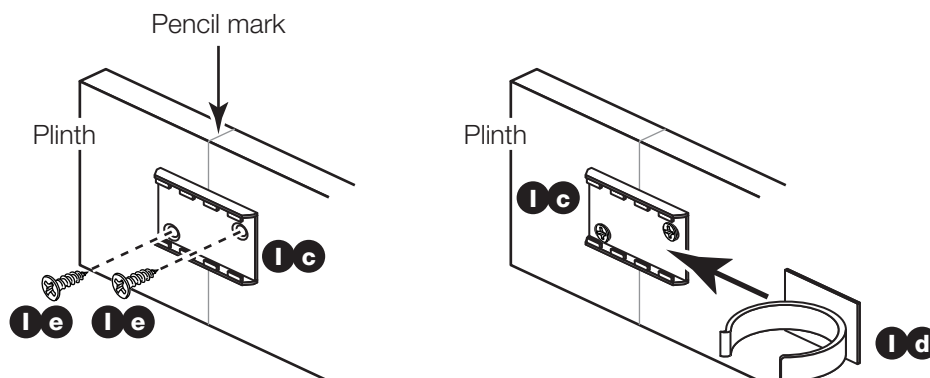

If you need help or have damaged or missing parts, call the Customer Helpline: 08456 400800 and quote the reference numbers on the component pages.

Argos Ltd, 489-499 Avebury Boulevard, Central Milton Keynes, MK9 2NW

