

2016-12-26 new 版本1

145.00 mm

BUSH

Instruction manual
V8211_03



210.00 mm

You'll soon be enjoying your new vacuum cleaner.

It all begins here, with your instructions. Don't worry, there's nothing too technical coming up. Just simple, step-by-step guidance to get you up and running quickly. Sound good? Then let's get started.

Help and Guidance

We're here to help you get the most from your vacuum cleaner. Should you require any guidance, a simple solution can often be found online at:

www.argos-support.co.uk

If you still require further assistance, call one of our experts on **TMTI HELPLINE 0345 604 0105 .**

If you require any technical guidance or find that your product is not operating as intended, a simple solution can often be found in the **Troubleshooting** section of these instructions.

Contents

1 Safety information

Safety information	6
Electrical	8

2 Getting to know your vacuum cleaner

Ready? Let's begin	10
Accessories	12

3 Installing your vacuum cleaner

Unpacking	14
Assembly	14

4 Using your vacuum cleaner

First use of vacuum cleaner	16
Using the vacuum cleaner	17

5 Care and maintenance

Cleaning	20
Care and maintenance	21
Technical specification	22

6 Product support

Troubleshooting	24
Help and assistance	25
Declaration of conformance to product Standards	26
Disposal	27

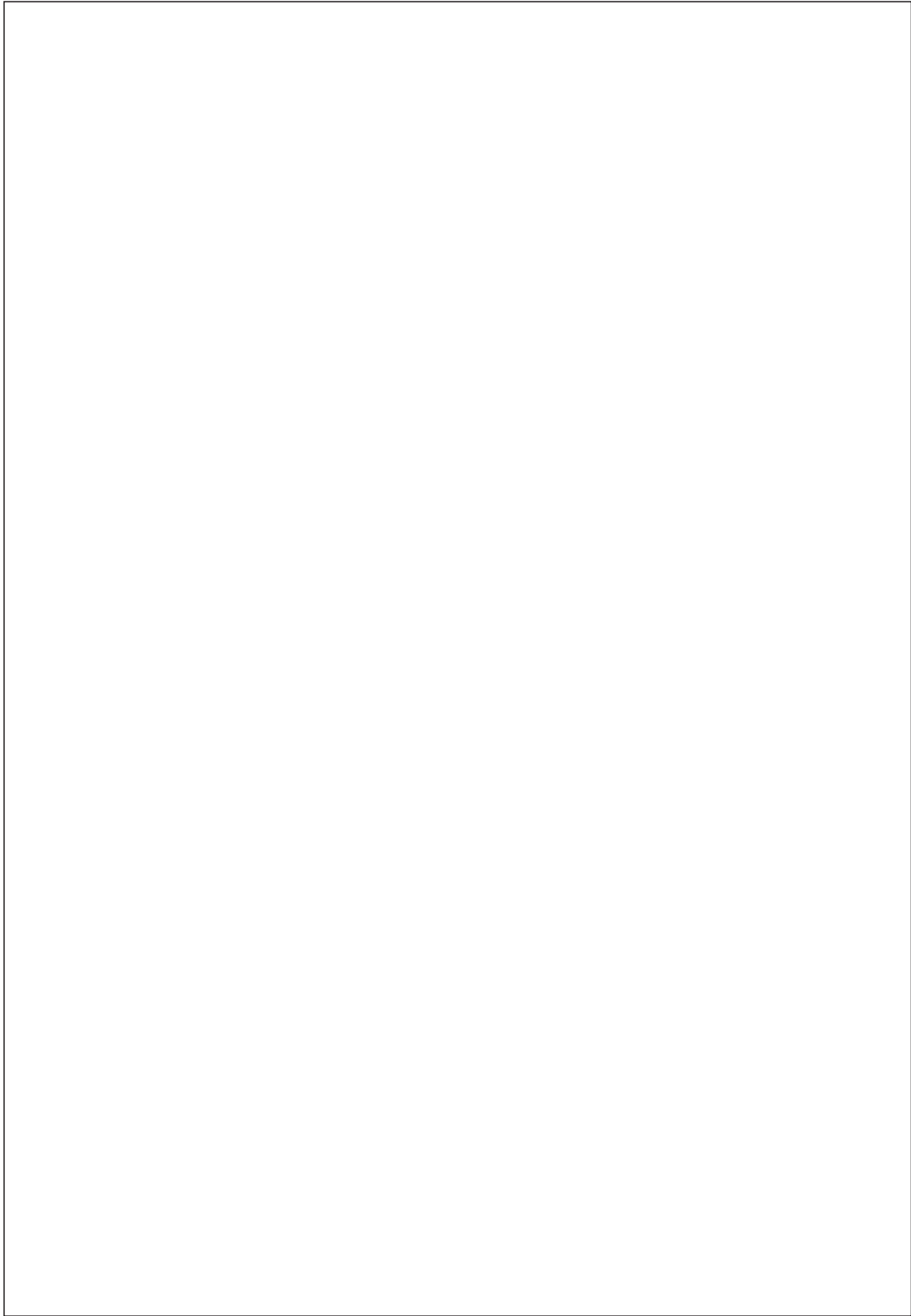

Safety information 1





Safety Information

Important - Please read all instructions before use and keep for future reference

WARNINGS

- This appliance is intended for domestic household use only and should not be used for any other purpose or in any other application, such as for non-domestic use or in a commercial environment.
- If the supply cord is damaged, it must be replaced by the manufacturer, its service agent or similarly qualified persons in order to avoid a hazard.
- Regarding the detailed instructions for the method and frequency of cleaning and the precautions during user maintenance, refer to the section "Care and maintenance" on page 20 of the manual.
- This appliance can be used by children aged from 8 years and above and persons with reduced physical, sensory or mental capabilities or lack of experience and knowledge if they have been given supervision or instruction concerning use of the appliance in a safe way and understand the hazards involved. Children shall not play with the appliance. Cleaning and user maintenance shall not be made by children without supervision.

If you require any technical guidance or find that your product is not operating as intended, a simple solution can often be found in the **Troubleshooting** section of these instructions.

Safety Information

Important - Please read all instructions before use and keep for future reference

- The plug must be removed from the socket-outlet before cleaning or maintaining the appliance.
- Following objects are strictly banned, otherwise the vacuum cleaner will be damaged or fire calamity will be caused, which bring such accidents as human body injuries:
 - Don't pick up large or sharp broken such as glasses.
 - Don't pick up harming or erodent liquids (solvent, corrosive, detergent...).
 - Don't pick up inflammable or explosive substance such as gasoline or alcohol.
 - Don't pick up/ vacuum burning or glowing objects (cigarettes, matches, hot ashes).

or online at www.argos-support.co.uk If you still require further assistance, call one of our experts on 0345 604 0105 .

Safety Information

Important - Please read all instructions before use and keep for future reference

Electrical



Any electrical work that is required to install this appliance MUST be carried out by a qualified electrician.

Before making any electrical connections, ensure that:

- Do not bend, stretch or pull the supply cable to avoid electric shock.
- Ensure the power socket is suitable for the maximum power of the machine.
- The supply voltage should be the same as that indicated in the technical specifications and the appliance rating plate.
- If the socket outlets in your home are not suitable for the plug supplied with this unit check with a qualified electrician for replacement.
- The use of adapters, multiple connectors or extension cables are not recommended.
- The appliance must be connected to a 220-240 volt 50Hz AC supply by means of a three pin socket, suitably earthed and protected by a 13 amp fuse.
- Should the fuse need to be replaced, a 13 amp fuse approved to BS1362 must be used.
- The plug contains a removable fuse cover that must be refitted when the fuse is replaced. If the fuse cover is lost or damaged, the plug must not be used until a replacement cover has been fitted or the plug is replaced.
- A damaged plug should be cut off as close to the plug body as possible, the fuse should be removed and the plug disposed of safely.

Plug replacement (UK & Ireland only)

Should you need to replace the plug; the wires in the power cable are coloured in the following way:

Blue – Neutral 'N'

Brown – Live 'L'

As the colours of the wires in the power cable may not correspond with the coloured markings identifying the terminals in your plug, and proceed as follows:

The blue wire must be connected to the terminal that is marked with the letter N.

The brown wire must be connected to the terminal that is marked with the letter L.

If power supply cord is damaged, it must be replaced by the manufacturer or its service agent or a similar qualified person in order to avoid a hazard.

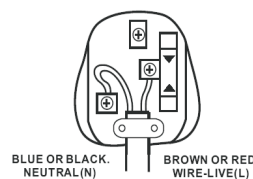

If you require any technical guidance or find that your product is not operating as intended, a simple solution can often be found in the **Troubleshooting** section of these instructions.

Getting to know your vacuum cleaner 2





Getting to know your vacuum cleaner

You'll be up and running in no time

Ready? Let's begin...

Please read these instructions carefully. They contain important information which will help you get the best from your Vacuum cleaner and ensure safe and correct installation and operation.

If you require any further assistance, our technical experts are happy to help. For full details, refer to the product support section at the end of these instructions.

If you require any technical guidance or find that your product is not operating as intended, a simple solution can often be found in the **Troubleshooting** section of these instructions.

Getting to know your Vacuum cleaner

You'll be up and running in no time

Components

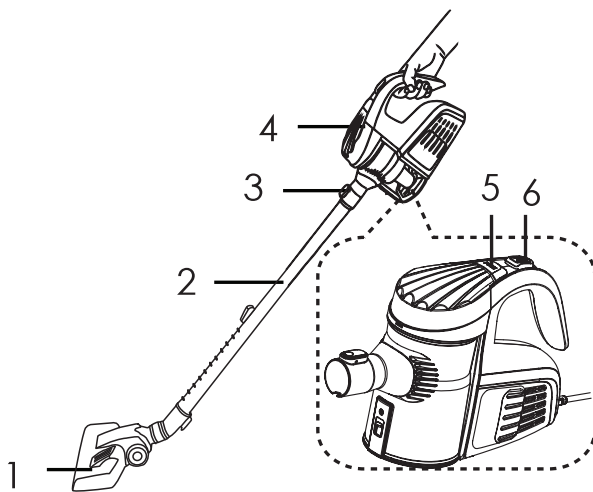

- 1. Cleaning head
- 2. Telescopic tubes
- 3. Tube socket
- 4. Dust container
- 5. Dust container release button

6. Power button

or online at www.argos-support.co.uk If you still require further assistance, call one of our experts on 0345 604 0105 .

Getting to know your vacuum cleaner

BUSH

11

Model no	Specification	Annual energy consumption	Hard floor	Carpet	Dust re-emission class
V8211_03	230V 50/60Hz 600W	A	C	E	F

Accessories

This machine includes below accessories, please install these parts by yourself before operating.

1. Telescopic tubes
2. Tube socket
3. Dusting brush
4. Crevice tool
5. Cleaning head

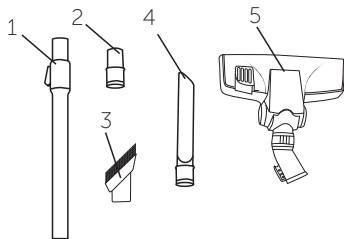

If you require any technical guidance or find that your product is not operating as intended, a simple solution can often be found in the **Troubleshooting** section of these instructions.

Installing your vacuum cleaner 3



Installing your Lightweight Bagless Vacuum cleaner

Bringing it all together

Unpacking

Unpacking your Vacuum cleaner

Carefully remove all packing materials including the foam base, accessories and dispose them correctly.

ASSEMBLY

Always disconnect the appliance from the mains socket before assembling or disassembling accessories.

1. First connect the tube socket with unit .
2. Insert telescopic tube into the tube socket at the front of the cleaner until you hear a click.
3. Push forward the switch on the telescope tube. Pull the tube to desired length. Then release the switch to lock the telescope tube in place

4. Attach the cleaning head to the end of the telescopic tube.

5. Assemble of part is completed. You can use the product

To remove the cleaning head and tubes, hold each piece tightly and pull firmly apart.

To remove the tube socket from the cleaner, whilst keeping the tube socket release button pressed, pull the tube socket out of the front of the cleaner and then release the button.

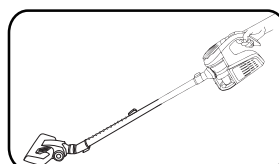
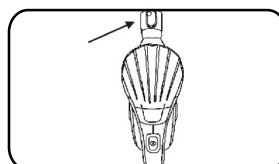
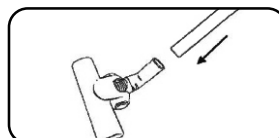
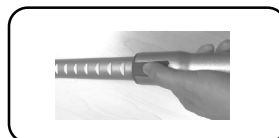
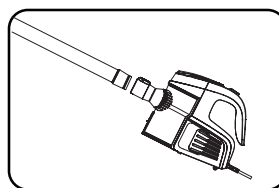
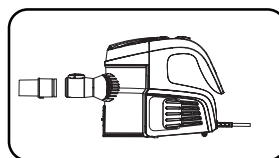

If you require any technical guidance or find that your product is not operating as intended, a simple solution can often be found in the **Troubleshooting** section of these instructions.

Using your vacuum cleaner 4



Using your vacuum cleaner

Getting the most from your appliance

First use of vacuum cleaner

CAUTION : Always switch off the vacuum cleaner before connecting or disconnecting the hose/atlachments or removing and emptying the dirt container.

IMPORTANT : The vacuum cleaner is equipped with a thermal cut-out. If for any reason the vacuum deaner does overheat. the thermostat will automatically turn the vacuum cleaner off. If this happens ,switch the vacuum cleaner off and unplug from electrical socket. Remove and empty the dirt container also check the vacuum deaner for blockages. Allow the vacuum cleaner to cool for approximately 1 hour (if you have cleaned the filters ,please wait 24 hours for the filters to fully dry before putting back into the machine).

If you require any technical guidance or find that your product is not operating as intended, a simple solution can often be found in the **Troubleshooting** section of these instructions.

Using the vacuum cleaner

Operation

Plug the appliance into the mains socket.
Press the power button on top of the appliance to switch on the appliance.
With handheld feature, you can clean from floor to ceiling.

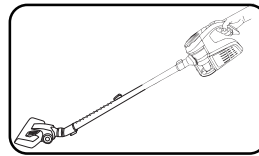

Advanced functions/use

Remove the cleaning head from the tubes then attach the crevice tool to the tubes. You can also attach the crevice tool directly to the front of the cleaner until a click is heard. The crevice tool is used for narrow gaps and hard-to-reach places. Use this crevice tool to vacuum down the side of cushions, corners, edges or small spaces.

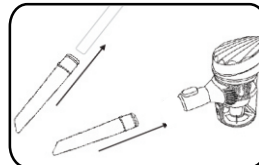

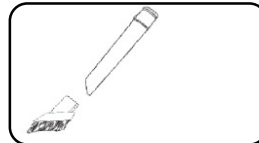

Using on wall/curtains

Use the dusting brush by attaching it to the crevice tool to clean more delicate surfaces, e.g. curtains.



Using on carpet/floor brush

Position1: Bristles extended for hard floors 
Position2: Bristles retracted for carpets 

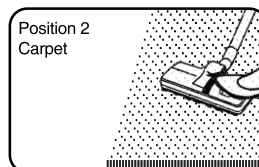
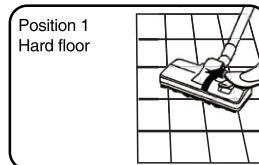

Use on the stairs

This machine can be used on stairs.
just connect accessories: tube socket,
crevice tool and dusting brush

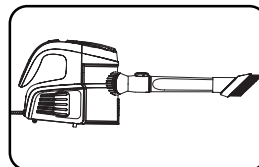

or online at www.argos-support.co.uk If you still require further assistance, call one of our experts on 0345 604 0105 .

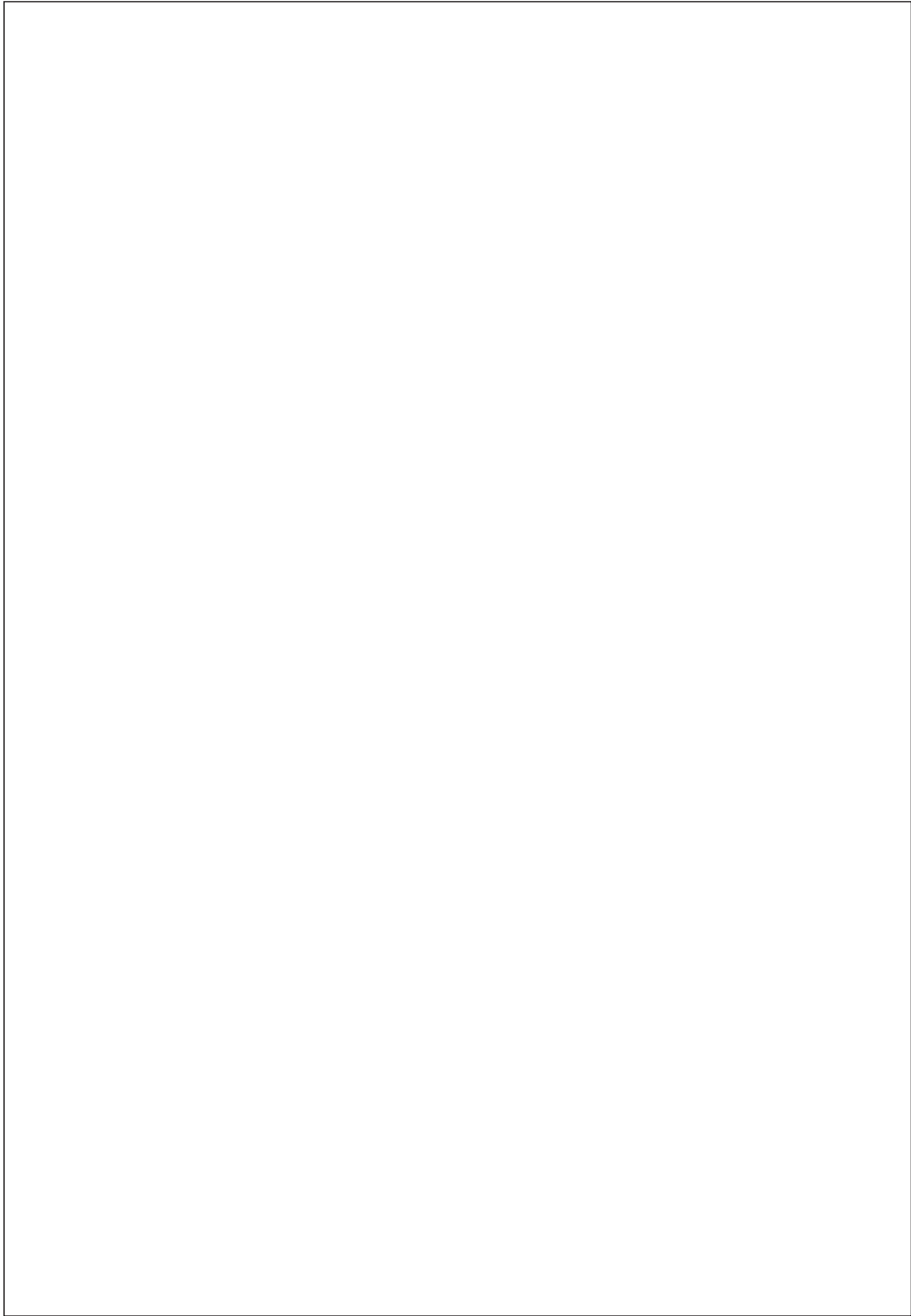

Care and maintenance

5



Care and maintenance

Looking after your appliance

Cleaning

Always switch off the appliance and unplug from the mains socket before carrying out any maintenance or cleaning.

Clean the outside of the appliance with a damp cloth. Dry thoroughly before use.

Never immerse the appliance in the water.

Do not use abrasive or chemical cleaning agents.

Empty the Dust Container

Empty the dust container when the dust reaches the MAX line.

Failure to do this will impair the efficiency of the cleaner.

1. Press the dust container release button to remove the dust container.

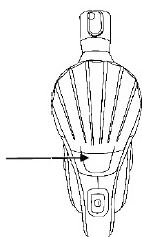

2. Hold the dust container over a bin and then push the latch downward to open the cover on the bottom of the dust to allow the dust fall out to bin.

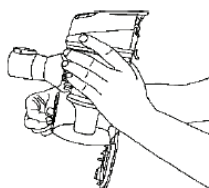

3. After empty the container, close the cover until the click sound created from the latch is heard.

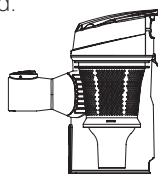

If you require any technical guidance or find that your product is not operating as intended, a simple solution can often be found in the **Troubleshooting** section of these instructions.

Care and maintenance

Cleaning the HEPA Filter

The high efficiency particulate air (HEPA) filter is an effective system in removing almost all indoor pollutants, dust mites, pollen and mould spores.

Filters require cleaning at least every 3-6 months (depending on the level of use). Don't use your vacuum cleaner without all the filters in place.

1. Pull the clip on the dust container lid outward to remove the lid.

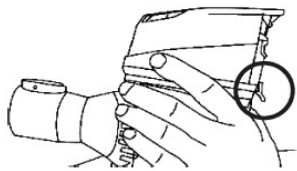

2. Hold the handle of the HEPA filter to rotate it anticlockwise and remove it.

3. Tap the HEPA filter over a bin to remove the dust.

4. Rotate the filter housing anticlockwise and remove it out of the dust container.



5. Wash the filter under water (max. 40 degree).

DO NOT USE DETERGENTS to clean all parts.

Leave it to dry for 24 hours or until fully dry before placing back in the vacuum cleaner.

6. Place the filter housing into the dust container and turn it clockwise until it locks into position.

7. Place the filter in the housing and then turn it clockwise until it locks into position.

8. Replace the dust container lid onto the dust container.

9. Attach the dust container back to the appliance until a click is heard.

or online at www.argos-support.co.uk If you still require further assistance, call one of our experts on 0345 604 0105.



Technical Specifications

Model Number	V8211_03
Voltage	220-240V~50/60Hz
Energy efficiency class	A
Annual energy consumption	24.4kWh/annum
Carpet cleaning performance class	E
Hard floor cleaning performance class	C
Dust re-emission class	F
Sound power level	80dB(A)
Rated input power	600W

If you require any technical guidance or find that your product is not operating as intended, a simple solution can often be found in the **Troubleshooting** section of these instructions.

Product support 6



Product support

Help is always at hand

TROUBLESHOOTING

Please check the following details before you have your appliance repaired by an authorised servicing agent.

1. Vacuum cleaner does not work.

You can check if the power plug is firmly inserted into the power outlet.

And if the power switch of the appliances is on.

2. Suction power becomes weak.

You can check if the brush or tube is clogged or damaged . Or check if the dust container is full or check if the filter is clogged and if the tubes are correctly attached. The possible solution is to immediately remove the obstruction. Or empty the dust container or clean the filter or reassemble the tubes.

3. Vacuum cleaner is overheating

You can check if the filter is blocked. The possible solution is to clean the filter.

4. Dust is coming out of the vacuum cleaner

You can check if the dust container is properly fitted to the cleaner. The possible solution is to refit the dust container to the cleaner.

If you require any technical guidance or find that your product is not operating as intended, a simple solution can often be found in the **Troubleshooting** section of these instructions.

Product support

Help is always at hand

Help and assistance

If you require any technical guidance or find that your wash vacuum cleaner is not operating as intended, a simple solution can often be found in the **Troubleshooting** section of these instructions or online at www.argos-support.co.uk

If you still require further assistance, call one of our experts on **0345 604 0105**. To help give us give you a fast and efficient service please have the following information ready:

Model Ref.

You can find these on the rating plate - a small information panel (usually a sticker or metal plate) on the rear of your appliance

Serial number

Date of purchase

This will be shown on your receipt

Local call rates applies*

Lines open 8am-7pm Monday to Saturday and 10am-4pm Sunday.

*Calls to Argos enquiry lines may attract a charge and set up fee from residential lines depending on your call plan/tarif. Mobile and other providers costs may vary, see www.bt.com/pricing for details.

For Security and training purposes, telephone calls to and from customer service centres maybe recorded and monitored. Calls from Republic of Ireland will attract international call charges.

or online at www.argos-support.co.uk If you still require further assistance, call one of our experts on **0345 604 0105**.

Product support

Help is always at hand



This appliance complies with the following CE directives:
2014/35/EU low voltage directive
2014/30/EU the EMC directive
2011/65/EU the ROHS directive



This is a class II appliance.

Notes on disposal:



This marking indicates that this product should not be disposed with other household wastes throughout the EU. To prevent possible harm to the environment or human health from uncontrolled waste disposal, recycle it responsibly to promote the sustainable reuse of material resources. To return your used device, please use the collection systems or contact the retailer where the product was purchased. They return and can take this product for environmental safe recycling.

If you require any technical guidance or find that your product is not operating as intended, a simple solution can often be found in the **Troubleshooting** section of these instructions.

Product support

Help is always at hand

BUSH

Call us now and activate your 12 month guarantee

Thank you for choosing Bush. Your new product is guaranteed against faults and breakdowns for 12 months. Don't forget to register it with us today so we can provide you with our best possible after-sales service and useful updates.

www.bushregistration.co.uk

FREEPHONE*

0800 597 8548

Lines are open 8am - 8pm, 365 days a year. *Calls may be recorded and monitored.

Your Bush Guarantee

This product is guaranteed for twelve months from the date of original purchase. Any defect that arises due to faulty materials or workmanship will be repaired free of charge (or if applicable the product will be replaced or the purchase price refunded) where possible during this period by the dealer from who you purchased the unit.

The guarantee is subject to the following provisions:

- The guarantee does not cover accidental damage, misuse, cabinet parts, knobs or consumable items.
- The product must be correctly installed and operated in accordance with the instructions contained in the manual.
- It must be used solely for domestic purposes. The guarantee will be rendered invalid if the product is re-sold or has been damaged by inexpert repair.
- Specifications are subject to change without notice.
- Bush disclaim any liability for loss or damage arising from the breakdown of the product.
- This guarantee is in addition to and does not diminish your statutory or legal rights.

Important Data Protection Information

If you provide us with information about another person, you confirm that they have appointed you to act for them, to consent to the processing of their personal data including sensitive personal data and that you have informed them of our identity and the purposes (as set out in the Important Data Privacy notice displayed overleaf) for which their personal data will be processed.

You are entitled to ask for a copy of the information we hold about you (for which we may charge a small fee) and to have any inaccuracies in your information corrected.

For quality control and training purposes, we may monitor or record your communications with us.

If your personal details change, if you change your mind about any of your marketing preferences or if you have any queries about how we use your information, please let us know by contacting our Data Protection Officer, Domestic & General, Leicester House 17 Leicester Street, Bedworth, Warwickshire CV12 8JP.

Guarantor: Argos Limited - 489 - 499 Avebury Blvd. - Milton Keynes - MK9 2NW

or online at www.argos-support.co.uk if you still require further assistance, call one of our experts on 0345 604 0105 .

BUSH

Contact:

www.argos-support.co.uk

Helpline: 0345 604 0105