

BUSH

Instruction manual

KBB500 CD Cassette Boombox





You'll soon be enjoying your new CD Cassette Boombox

It all begins here, with your instructions. Don't worry, there's nothing too technical coming up. Just simple, step-by-step guidance to get you up and running quickly. Sound good? Then let's get started.

Help and Guidance

We're here to help you get the most from your CD Cassette Boombox. Should you require any guidance, a simple solution can often be found online at:

www.argos-support.co.uk

If you still require further assistance, call one of our experts on **0345 604 0105**.

If you require any technical guidance or find that your product is not operating as intended, a simple solution can often be found in the **Troubleshooting**

BUSH

Contents

1 Safety information

Safety information 6

2 Getting to know your CD Cassette Boombox

Ready? Let's begin 10

Connection 12

Power connection/Inserting batteries(optional) 13

Auxiliary connection 14

3 Using your CD Cassette Boombox

Inserting CD 16

Playing a CD 17

Programmed play mode 18

Playing a Cassette 19

Recording from the Radio/CD/AUX 19

FM radio

4 Other information

Technical specification 22

5 Product support

Troubleshooting 24

Help and assistance 25

Disposal 26

Guarantee 27

Safety information 1





Safety information

Important - Please read these instructions fully before installing or operating

Please take the time to follow the instructions in this owner's guide carefully. It will help you set up and operate your system properly and enjoy all of its advanced features.

- Please save this owner's guide for future reference.
- The product label is located on the back of the product.

- Do not use this apparatus near water or moisture.
- Do not use this product near a bathtub, washbowl, kitchen sink, and laundry tub, in a wet basement, near a swimming pool, or anywhere else that water or moisture is present.
- Do not leave it in high temperatures as electronic devices and plastic parts may warp in heat.
- Do not block or cover slots, holes or openings on the product by placing on soft furnishings such as carpets, rugs or beds as these are provided for functionality and/or ventilation to ensure safe operation of the product.
- Do not store in dusty or dirty areas.
- Servicing is required when the apparatus has been damaged in any way: such as liquid has been spilled or objects have fallen into the apparatus; the apparatus has been exposed to rain or moisture, does not operate normally, or has been dropped.
- Do not attempt to open the product. This product does not contain any user serviceable parts. Unauthorized handling of the device may damage it and will void your warranty.

Opening or removing covers may expose you to dangerous voltages or other hazards. To prevent risk of fire or electric shock, avoid overloading wall outlets, extension cords, or integral convenience receptacles.

If this product will not be used for a long period of time, make sure that all of the batteries are removed from the battery compartments.

If you require any technical guidance or find that your product is not operating as intended, a simple solution can often be found in the **Troubleshooting**



Safety information

Important - Please read these instructions fully before installing or operating



The exclamation point within an equilateral triangle is intended to alert the user to the presence of important operation and maintenance (servicing) instructions in the literature accompanying the appliance.

Fig 1.



The lightning flash with arrowhead symbol, within an equilateral triangle, is intended to alert the user to the presence of uninsulated dangerous voltage within the product's enclosure that may be of sufficient magnitude to constitute a risk of electric shock to persons..

Fig 2.

Getting to know your CD Cassette Boombox

2



Getting to know your CD Cassette Boombox

You'll be up and running in no time

Ready? Let's begin...

Please read these instructions carefully. They contain important information which will help you get the best from your product and ensure safe and correct installation and operation.

If you require any further assistance, our technical experts are happy to help. For full details, refer to the product support section at the end of these instructions.

Accessories

1. AC power cord

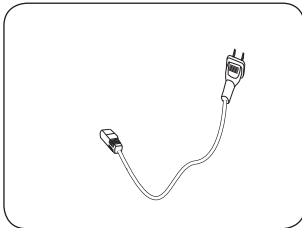

Accessory

2. Instruction manual

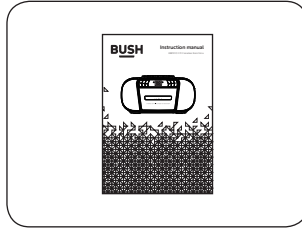

Accessory

Fig 3.

If you require any technical guidance or find that your product is not operating as intended, a simple solution can often be found in the **Troubleshooting**

Getting to know your CD Cassette Boombox

You'll be up and running in no time

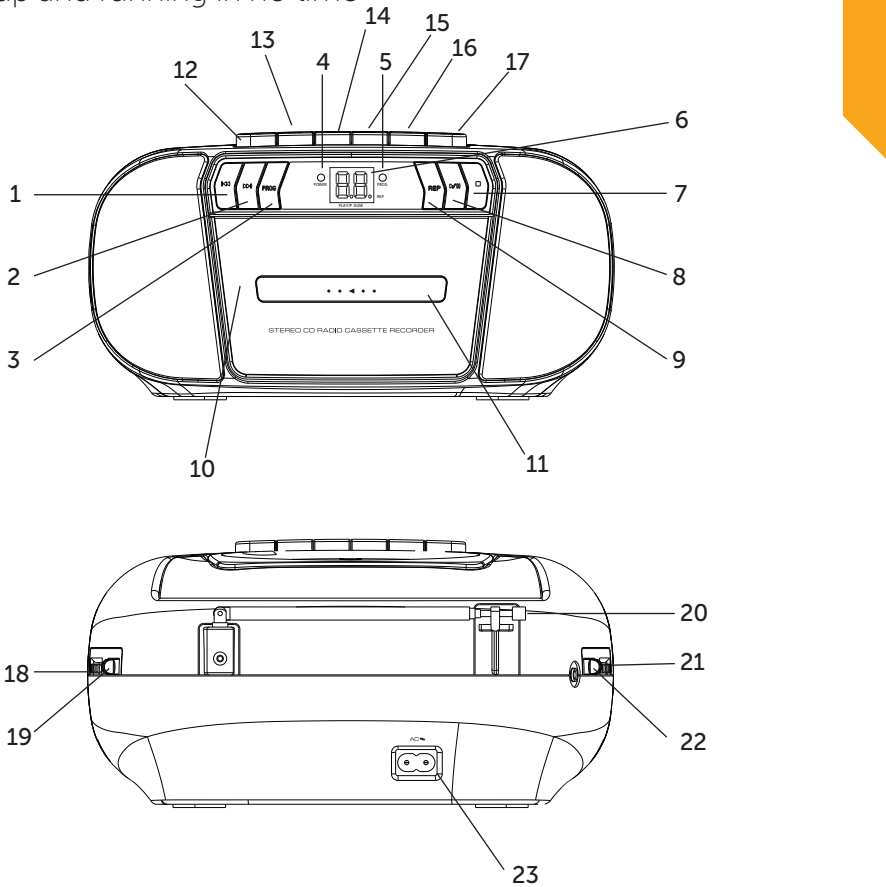

Fig 4.

- | | | |
|---------------------------|---------------------|------------------------------------|
| 1. Skip Backward | 10. Cassette Door | 18. Tuning |
| 2. Skip Forward | 11. Cassette Record | 19. Aux In |
| 3. Program | 12. Pause | 20. Telescopic Antenna |
| 4. Power Indicator | 13. Stop/Eject | 21. Volume |
| 5. Play/Program Indicator | 14. Rewind | 22. FM Mono/FM ST/TAPE OFF/CD(Aux) |
| 6. LED Display | 15. Fast Forward | 23. AC Line In |
| 7. Stop/Eject | 16. Play | |
| 8. Play/Pause | 17. Record | |
| 9. Repeat | | |

section of these instructions, or online at www.argos-support.co.uk If you still require further assistance, call one of our experts on 0345 604 0105.

Getting to know your CD Cassette Boombox

You'll be up and running in no time

Connection

Please consider carefully where your boombox will be situated and make sure that it is:

- on a flat and stable surface
- within 1.4 metres of a power socket
- where you can fully extend the wire radio aerial
- at least 1 metre away from other electrical appliances to avoid interference.

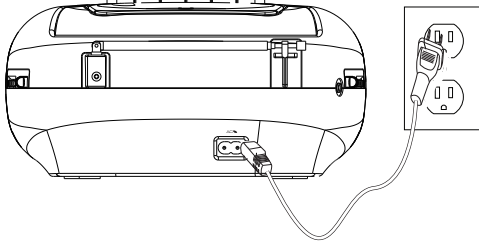

Fig 5.

1. Unwind the power cable from the back of the boombox.
2. Extend the wire radio aerial. A vertical position is recommended for maximum signal strength.
3. Plug the mains power plug into the mains power wall socket and switch on (Fig5) . The red power LED to the left of the display will light up.

If you require any technical guidance or find that your product is not operating as intended, a simple solution can often be found in the **Troubleshooting**

Getting to know your CD Cassette Boombox

You'll be up and running in no time

Power connection / Inserting batteries (optional)

Before inserting the batteries (not included), please ensure that the Boombox is unplugged from the mains power supply.

1. Underneath the Boombox, remove the battery compartment cover.
2. Insert 6 "C" size (UM-2) batteries(**Fig6**), making sure to note the '+' and '-' markings and position the batteries the correct way around.
3. Replace the battery compartment cover, making sure that it 'clicks' home.

Note: When the battery power is low, you will notice that the audio quality will be a little distorted and the volume will be quieter. Please switch o the CD Cassette Boombox and replace the batteries.

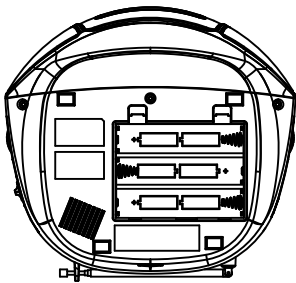

Fig 6.

Getting to know your CD Cassette Boombox

You'll be up and running in no time

Auxiliary connection

Using a 3.5mm audio input connection cable (not included), allows for a quick and easy connection to an external sound source.

1. Connect one end of a 3.5mm audio connection cable to the headphone or auxiliary out socket of your secondary device, connect the other end to the Line in socket on the back of your Boombox.
2. Slide the Mode switch to 'CD (AUX)'.
3. Press the Play button on your external device to start playback through the Boombox speakers.
4. To gain optimal volume levels, adjust the volume control on both the secondary device and on the Boombox.

Note: It is recommended that you unplug the audio cable from the Line in socket after you have finished listening to your external device, as the CD player cannot be used whilst an audio cable is connected. Please wait for approximately 15 seconds after unplugging the audio cable, for the Boombox to return to CD mode.

If you require any technical guidance or find that your product is not operating as intended, a simple solution can often be found in the **Troubleshooting**

Using your CD Cassette Boombox

3



Using your CD Cassette Boombox

Let's get started

Inserting a CD

Check that your Boombox is in CD (AUX) mode.

1. Lift up the lid of the CD player on the front edge, where there is a scooped recess.

Note: On first use, please remove the protective card from the CD compartment.

2. Place an audio CD with its label side upward in the CD compartment and close the lid of the CD player.
3. The total number of tracks on the CD will appear in the LED Display after a few seconds.

If you require any technical guidance or find that your product is not operating as intended, a simple solution can often be found in the **Troubleshooting**

Using your CD Cassette Boombox

Let's get started

Playing a CD

Your Boombox will play audio CDs as well as CD-Recordable (CD-R) and CD-Rewritable (CD-RW) CDs. Do not attempt to play CD-ROM, CDI, VCD, DVD or computer CDs.

Note: If you stop or pause playing a CD for 20 minutes, your Boombox will switch off automatically.

1. Press the CD PLAY/PAUSE button. The Play/Program Indicator will light and the CD will start playing from the first track.
2. Adjust the Volume control to obtain the desired sound level from the Built-in Speakers.
3. To suspend playing, press the CD PLAY/PAUSE button and the track no. of the playback track will flash.
To resume playing, press the CD PLAY/PAUSE button again.
4. You can choose to play your favorite track directly by pressing either the Skip Forward button or Skip Backward button. The LED Display will indicate the correct track number selected.
5. To locate a particular passage within a track, keep the CD Search Forward button or CD Search Backward button depressed until it is found.
6. To repeat a particular track, press the CD Repeat button until the CD Repeat Indicator flashes.

To repeat the entire CD, press the CD Repeat button again until the CD Repeat Indicator lights steadily.

To repeat off, press the CD Repeat button again until the CD Repeat Indicator disappear.

Using your CD Cassette Boombox

Let's get started

Programmed play mode

In programmed play mode, you can program the play order of the tracks on your CD.

You can program up to 20 tracks in total.

1. In CD stop mode, press the PROGRAM button once. PROG LED will appear and blink in the LED Display.
2. Press the CD Skip Forward button or CD Skip Backward button to select the song to be programmed.
3. Press the PROG button again to store selection. The LED display will blink to prompt for input.
4. Press the CD Skip Forward button or CD Skip Backward button to select the next song to be programmed and press the PROG button to store the second selection.
5. You may repeat steps 2 – 4 to program up to a total of 20 tracks.
6. Press the CD PLAY/PAUSE button to start playing in the programmed sequence.
7. To cancel programmed play, press the CD STOP button.

To exit programmed play mode, press the CD STOP button twice

If you require any technical guidance or find that your product is not operating as intended, a simple solution can often be found in the **Troubleshooting**

Using your CD Cassette Boombox

Let's get started

Playing a Cassette

Cassette playback

1. Set the FUNCTION selector switch to the TAPE (OFF) position.
2. Press the STOP/EJECT button to open the cassette door, insert a cassette into the compartment and close the door.
3. Press the PLAY button, and adjust to the required volume level. When the tape comes to the end, it will automatically stop and the button will release.
4. During playback the cassette can be fast forwarded by pressing down the FAST FWD button or rewound with the REWIND button. Pressing STOP/EJECT will cancel all functions.
5. Press PAUSE button to pause playback of a cassette, press again to enable playback.
6. To eject the cassette, press the STOP/EJECT button to cancel any functions. Press again to open the cassette compartment door and remove the cassette.

Recording from the Radio/CD/AUX

1. Press the CASSETTE WINDOW button to start recording either from the Radio/CD/AUX. Use the FUNCTION selector to choose your signal source accordingly.
2. Press STOP/EJECT button to stop operation or leave the recording until the cassette reaches the end where it will stop automatically.

Open the Cassette door and insert a pre-recorded cassette tape with the exposed tape facing upwards. Close the Cassette door.

FM radio

1. Set the FUNCTION selector switch to the (FM ST. (Stereo) or FM MONO) position.
2. Adjust the sound level using the VOLUME control.
3. Rotate the TUNING control to set the frequency required.
4. To insure maximum FM tuner reception, the Telescopic Antenna should be fully extended and rotated to obtain the best possible station reception.

section of these instructions, or online at www.argos-support.co.uk If you still require further assistance, call one of our experts on 0345 604 0105.

Other information

4



Other information

Helpful technical information

Specification

Power adaptor:	Input AC230-240V/50Hz
Batteries:	6 x 1.5V C size (UM-2) (Optional, not supplied)
Output:	1W x 2 RMS
FM Frequency:	88MHz to 108 MHz

If you require any technical guidance or find that your product is not operating as intended, a simple solution can often be found in the **Troubleshooting**

Product support 5



Product support

Help is always at hand

Troubleshooting

Symptoms	Possible cause	Solution
Noise or sound distorted on FM broadcast	Station not tuned properly. Telescopic antenna is not fully extended	Fine tune the FM broadcast station. Fully extend the FM telescopic antenna
FM no sound	Unit not in Tuner mode, FM ST. or FM MONO band. Volume at minimum.	Slide function selector to select FM ST. or FM MONO. Increase volume
Unable to play a CD	Unit not in CD function mode. CD is installed incorrectly.	Select CD function mode. Insert CD with label side up.
CD skips while playing	Disc is dirty or scratched.	Wipe CD with clean cloth or use another disc.
Intermittent sound from CD player	Dirty or defective disc. Dirty pick up lens. Player is subject to excessive shock or vibration.	Clean or replace the defective disc. Use a CD-lens cleaning disc to clean the lens. Relocate the player away from shock or vibration.
Cassette player no sound	Unit not at TAPE function mode. Volume at minimum.	Slide function selector to TAPE. Increase volume.
Cassette playback sound is unsteady	Dirty cassette heads. Cassette damaged.	Use a tape head cleaner. Try an alternative cassette.
Cannot record to a Cassette	Cassette erasure prevention tabs are broken.	Use an alternative cassette. Use sticky tape to cover the erasure prevention tab locations.
Unit enters STANDBY mode after 20 minutes (approx.).	Power saving function enabled	This is normal operation due to new ECO regulation requirements this product incorporates a power saving feature.

If you require any technical guidance or find that your product is not operating as intended, a simple solution can often be found in the **Troubleshooting**

Product support

Help is always at hand

Help and assistance

If you require any technical guidance or find that your CD Casstte Boombox is not operating as intended, a simple solution can often be found in the **Troubleshooting** section of these instructions or online at www.argos-support.co.uk

If you still require further assistance, call one of our experts on **0345 604 0105** . To help give us give you a fast and efficient service please have the following information ready:

Model Ref.	<input type="text"/>	You can find these on the rating plate - a small information panel (usually a sticker or metal plate) on the rear of your product.
Serial number	<input type="text"/>	
Date of purchase	<input type="text"/>	This will be shown on your receipt

Local call rates applies*

Lines open 8am-7pm Monday to Saturday and 10am-4pm Sunday.

*Calls to Argos enquiry lines may attract a charge and set up fee from residential lines depending on your call plan/tariff. Mobile and other providers costs may vary, see www.bt.com/pricing for details.

For security and training purposes, telephone calls to and from customer service centres may be recorded and monitored. Calls from Republic of Ireland will attract international call charges.

section of these instructions, or online at www.argos-support.co.uk If you still require further assistance, call one of our experts on **0345 604 0105**.

Product support

Help is always at hand

Disposal

The symbol on the product or its packaging indicates that this product may not be treated as household waste. Instead it should be handed over to the applicable collection point for the recycling of electrical and electronic equipment. By ensuring this product is disposed of correctly, you will help prevent potential negative consequences for the environment and human health, which could otherwise be caused by inappropriate waste handling of this product. For more detailed information about recycling this product, please contact your local council office your household waste disposal service or the shop where the product was purchased.



If you require any technical guidance or find that your product is not operating as intended, a simple solution can often be found in the **Troubleshooting**

Product support

Help is always at hand

BUSH

Call us now and activate your 12 month guarantee

Thank you for choosing Bush. Your new product is guaranteed against faults and breakdowns for 12 months. Don't forget to register it with us today so we can provide you with our best possible after-sales service and useful updates.

www.bushregistration.co.uk

FREEPHONE*

0800 597 8548

Lines are open 8am - 8pm, 365 days a year. *Calls may be recorded and monitored.

Your Bush Guarantee

This product is guaranteed for twelve months from the date of original purchase. Any defect that arises due to faulty materials or workmanship will be repaired free of charge (or if applicable the product will be replaced or the purchase price refunded) where possible during this period by the dealer from who your purchased the unit.

The guarantee is subject to the following provisions:

- The guarantee does not cover accidental damage, misuse, cabinet parts, knobs or consumable items.
- The product must be correctly installed and operated in accordance with the instructions contained in the manual.
- It must be used solely for domestic purposes. The guarantee will be rendered invalid if the product is re-sold or has been damaged by inexpert repair.
- Specifications are subject to change without notice.
- Bush disclaim any liability for loss or damage arising from the breakdown of the product.
- This guarantee is in addition to and does not diminish your statutory or legal rights.

Important Data Protection Information

If you provide us with information about another person, you confirm that they have appointed you to act for them, to consent to the processing of their personal data including sensitive personal data and that you have informed them of our identity and the purposes (as set out in the Important Data Privacy notice displayed overleaf) for which their personal data will be processed.

You are entitled to ask for a copy of the information we hold about you (for which we may charge a small fee) and to have any inaccuracies in your information corrected.

For quality control and training purposes, we may monitor or record your communications with us.

If your personal details change, if you change your mind about any of your marketing preferences or if you have any queries about how we use your information, please let us know by contacting our Data Protection **Officer, Domestic & General, Leicester House** 17 Leicester Street, Bedworth, Warwickshire CV12 8JP.

Guarantor: Argos Limited - 489 - 499 Avebury Blvd. - Milton Keynes - MK9 2NW

section of these instructions, or online at www.argos-support.co.uk If you still require further assistance, call one of our experts on **0345 604 0105**.

BUSH

Contact:

www.argos-support.co.uk

Helpline: 0345 604 0105