

Matrix Desk

Assembly Instructions - Please keep for future reference

619/1645

619/1638

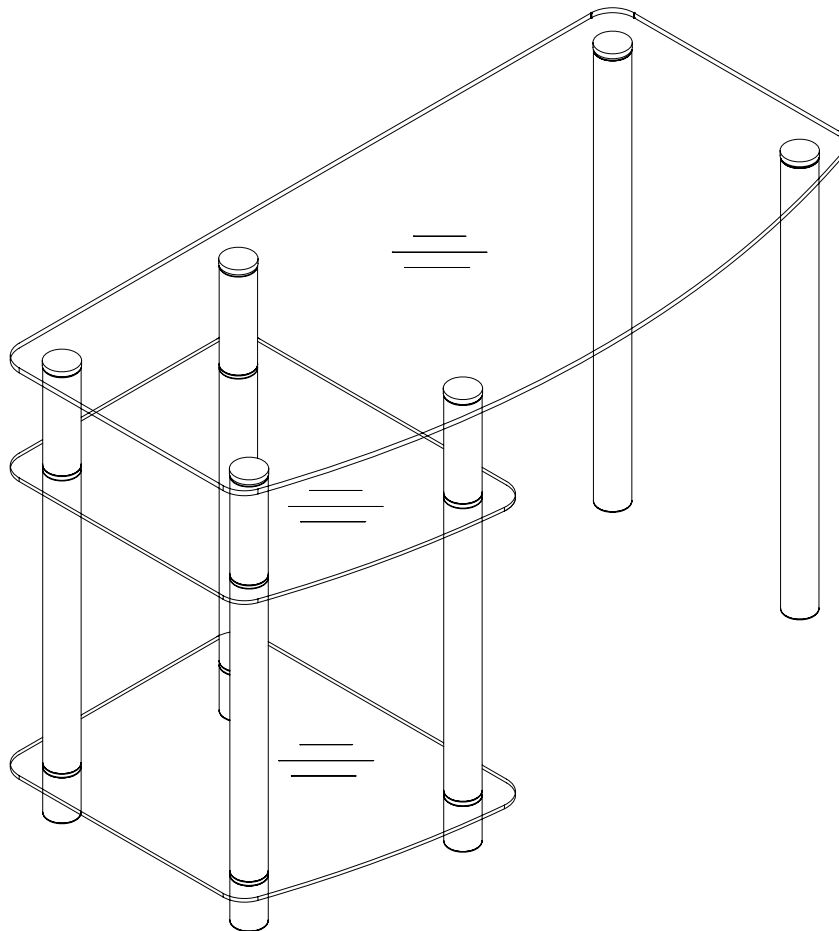

Dimensions

Width - 115cm

Depth - 55cm

Height - 75cm

Important - Please read these instructions fully before starting assembly

If you need help or have damaged or missing parts, call the **Customer Helpline: 08456 400800**



Safety and Care Advice

Important – Please read these instructions fully before starting assembly

- Check you have all the components and tools listed on pages 2 and 3.
- Remove all fittings from the plastic bags and separate them into their groups.
- Keep children and animals away from the work area, small parts could choke if swallowed.
- Make sure you have enough space to layout the parts before starting.
- Do not stand or put excessive weight on the product, this could cause damage.
- Assemble the item as close to its final position (in the same room) as possible.
- Parts of the assembly will be easier with 2 people.
- Dispose of all packaging carefully and responsibly.
- Place the product on flat and steady surface during use.
- Assemble on a soft level surface to avoid damaging the unit or your floor.
- Keep these instructions for further use.
- To ensure an easier assembly, we strongly advise that all fittings are only finger tightened during initial assembly. Only upon completion of the assembly should all fixing points be fully tightened.

Glass safety

- This product complies with BS EN 12521: 2009.
- Imported by:
Home Retail Group.
489-499 Avebury Boulevard.
Saxon Gate West.
Central Milton Keynes.
MK9 2NW
- Product Cat no.:619/1645(D) (Clear Glass)
Cat no.:619/1638(D) (Black Glass)
- P/O No:
- If the glass is chipped or broken, stop using the product and consult the Manufacturer or Supplier.

Warnings

- a) Do not place very hot or very cold items on the glass surface(s) unless adequately thick table mats are used to prevent such items from coming into contact with the glass.
- b) Do not sit or stand upon the glass surface(s).
- c) Do not use the glass as a chopping surface. Do not strike the glass with hard or pointed items.
- d) When cleaning glass panels use a damp cloth or leather with washing up liquid or soft soap if necessary, do not use washing powders or any other substance containing abrasives since these substances scratch glass.

Care and maintenance

- Only clean using a damp cloth and mild detergent, do not use bleach or abrasive cleaners.
- From time to time check that there are no loose screws on this unit.
- This product should not be discarded with household waste. Take to your local authority waste disposal centre.

Components - Parts

If you have damaged or missing components, call the **Customer Helpline: 08456 400800**

Please check you have all the parts listed below

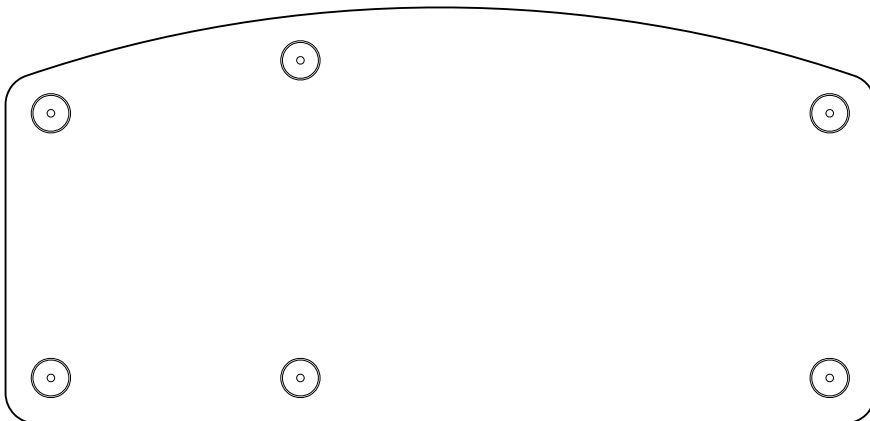

1 Glass top (115 x 55 cm)



3 Leg x 2 (73 x 5 cm)

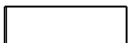

4 Support (Short) x 4 (16.5 x 5cm) (Plastic cap one end only)

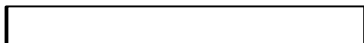

5 Support (Long) x 4 (48 x 5cm) (Plastic caps both ends)



6 Feet x 4 (7.6 x 5cm) (Plastic cap one end only)

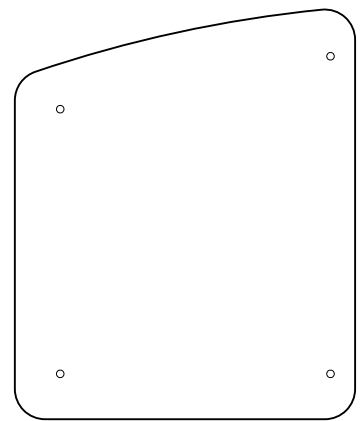





2 Glass shelf x 2 (53.9 x 42.5 cm)

Components - Fittings

If you have damaged or missing components, call the **Customer Helpline: 08456 400800**

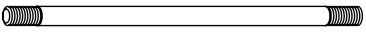
Please check you have all the fittings listed below

Note: The quantities below are the correct amount to complete the assembly. In some cases more fittings may be supplied than are required.

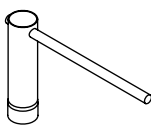
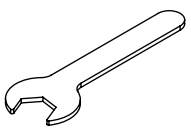
A  720mm Threaded stud x 6	B  Nut x 12	C  Spring washer x 6
D  End cap x 6	E  Box spanner x 1	F  Spanner x 1

Tools required

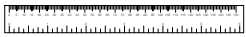

Ruler/tape
measure

Ruler - Use this ruler to help correctly identify the screws

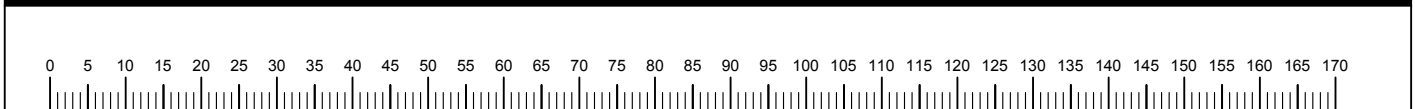

Assembly Instructions

Step 1

Attaching threaded rod



Warning:
With help,
carefully place
glass top **1** upside
down onto a clean flat
surface.

a: Screw nuts **B** onto
the ends of threaded
rods **A**.

b: Screw threaded rods
A into the metal discs on
the underside of glass
top **1**.

Use spanner **F** to fully
tighten nuts **B** down
onto the metal discs.

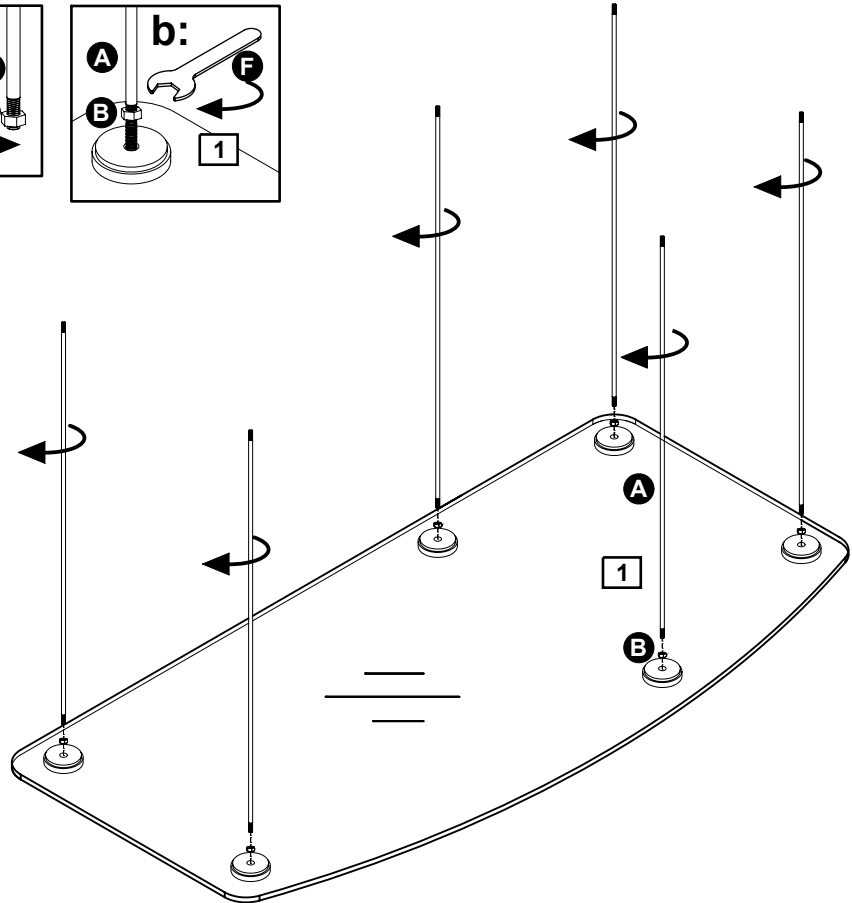
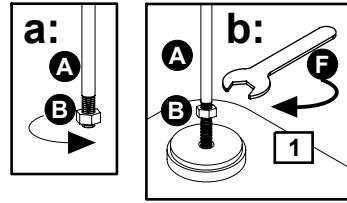

Step 2

Attaching legs

Locate legs **3** over
threaded rods **A** on one
side of top **1**.

Note: Ensure the metal
plates welded inside the
ends of legs **3** are
facing upwards.

Using box spanner **E**,
fully tighten fixings **B** and
C to secure the legs.

Fit end caps **D**.

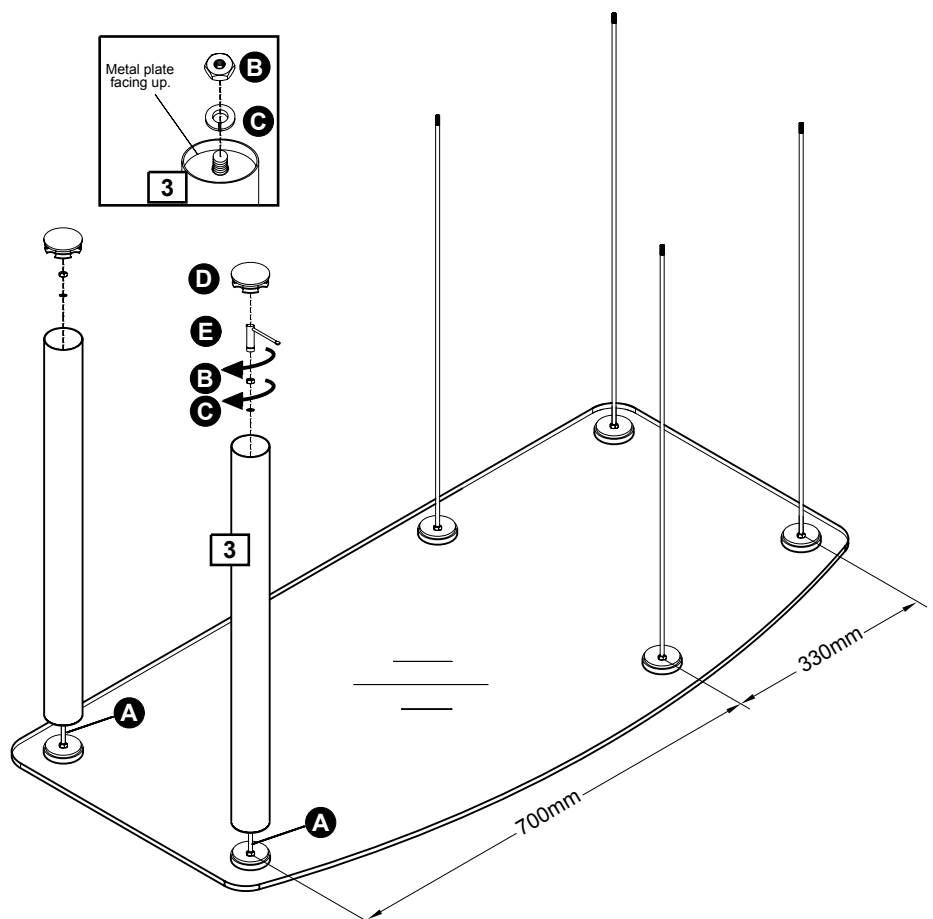
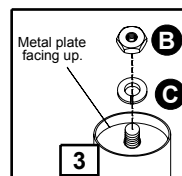

Assembly Instructions

Step 3

Locating middle glass shelf

Locate short supports **4** over threaded rods **A**.

Note: Ensure the plastic caps in the ends of supports **4** are facing up.



Warning: Carefully locate glass shelf **2** over the threaded rods **A**.

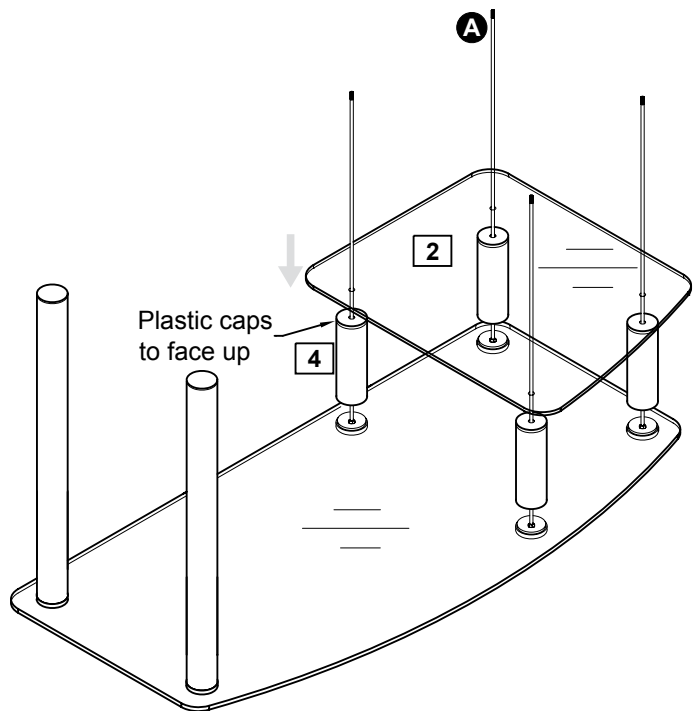

Step 4

Locating lower glass shelf

Locate long supports **5** over threaded rods **A**.



Warning: Carefully locate glass shelf **2** over the threaded rods **A**.

Locate feet **6** over the threaded rods.

Note: Ensure the metal plates welded inside the ends of feet **6** are facing upwards.

Using box spanner **E**, fully tighten fixings **B** and **C** to secure the feet.

Fit end caps **D**.

With help, carefully turn the desk upright.



Warning: The desk is heavy. Lift with care.

Assembly is complete.

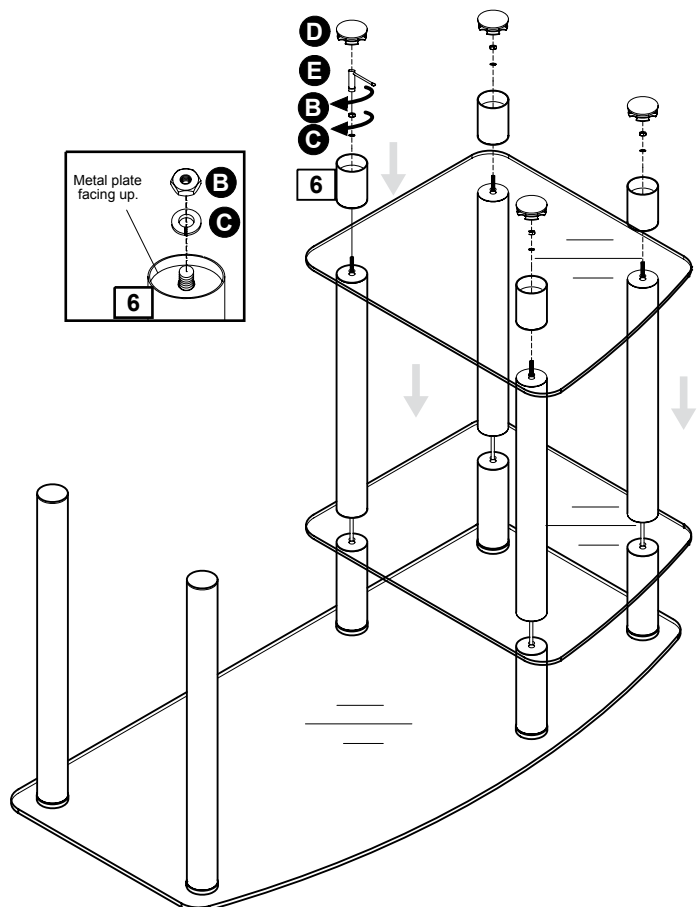

If you need help or have damaged or missing parts, call the **Customer Helpline: 08456 400800**
Home Retail Group, 489-499 Avebury Boulevard, Saxon Gate West, Central Milton Keynes, MK9 2NW

Matrix Desk

Assembly Instructions - Please keep for future reference

619/1638

hygena

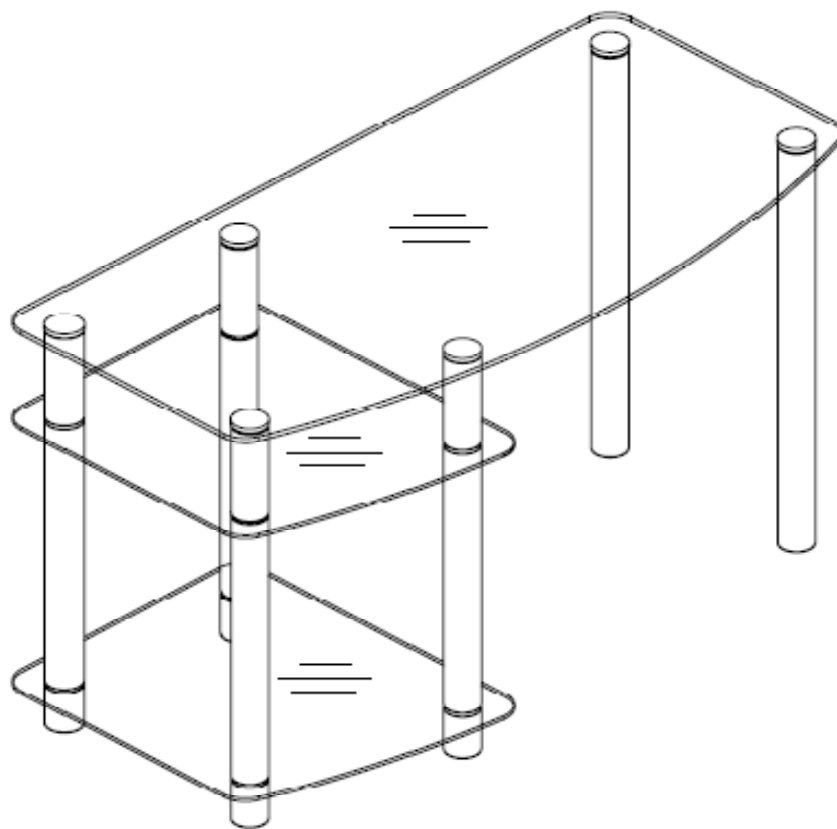

Dimensions

Width - 115cm

Depth - 55cm

Height - 75cm

Important - Please read these instructions fully before starting assembly

If you need help or have damaged or missing parts, call the **Customer Helpline: 08456 400800**

Issue 1 - 9/04/11

Insert Additional Pages If Required.



Safety and Care Advice

Important – Please read these instructions fully before starting assembly

- Check you have all the components and tools listed on pages 2 and 3.
- Remove all fittings from the plastic bags and separate them into their groups.
- Keep children and animals away from the work area, small parts could choke if swallowed.
- Make sure you have enough space to layout the parts before starting.
- Do not stand or put excessive weight on the product, this could cause damage.
- Assemble the item as close to its final position (in the same room) as possible.
- Parts of the assembly will be easier with 2 people.
- Dispose of all packaging carefully and responsibly.
- Place the product on flat and steady surface during use.
- Assemble on a soft level surface to avoid damaging the unit or your floor.
- Keep these instructions for further use.
- To ensure an easier assembly, we strongly advise that all fittings are only finger tightened during initial assembly. Only upon completion of the assembly should all fixing points be fully tightened.

Glass safety

- This product complies with BS EN 12521: 2009.
- Imported by:
Home Retail Group.
489 499 Avebury Boulevard.
Saxon Gate West.
Central Milton Keynes.
MK9 2NW
- Product Cat no.:619/1645(D) (Clear Glass)
Cat no.:619/1638(D) (Black Glass)
- P/O No:
- If the glass is chipped or broken, stop using the product and consult the Manufacturer or Supplier.

Warnings

- a) Do not place very hot or very cold items on the glass surface(s) unless adequately thick table mats are used to prevent such items from coming into contact with the glass.
- b) Do not sit or stand upon the glass surface(s).
- c) Do not use the glass as a chopping surface. Do not strike the glass with hard or pointed items.
- d) When cleaning glass panels use a damp cloth or leather with washing up liquid or soft soap if necessary, do not use washing powders or any other substance containing abrasives since these substances scratch glass.

Care and maintenance

- Only clean using a damp cloth and mild detergent, do not use bleach or abrasive cleaners.
- From time to time check that there are no loose screws on this unit.
- This product should not be discarded with household waste. Take to your local authority waste disposal centre.

Components - Parts

If you have damaged or missing components,
call the Customer Helpline: 08456 400800

Please check you have all the parts listed below

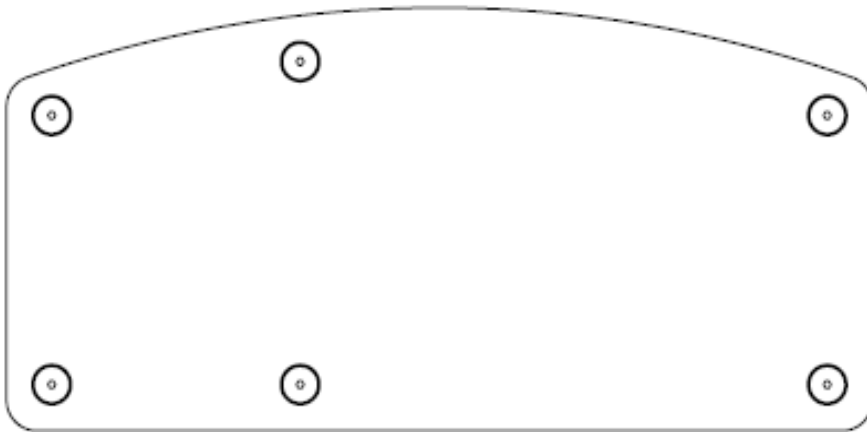

1 Glass top (115 x 55 cm)

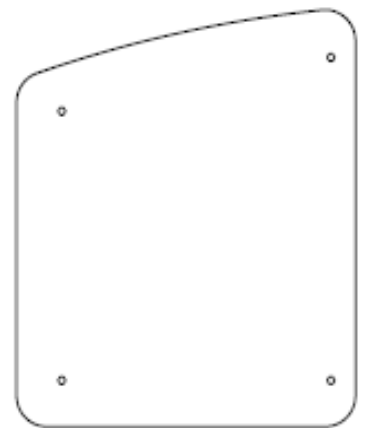

2 Glass shelf x 2
(53.9 x 42.5 cm)

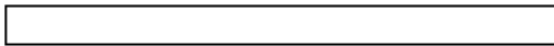

3 Leg x 2 (73.6x5cm)



4 Support (Short) x 4 (16x5cm) (Plastic cap one end only)



5 Support (Long) x 4 (48 x 5cm) (Plastic caps both ends)





6 Feet x 4 (8x5cm) (Plastic cap one end only)

Components - Fittings

If you have damaged or missing components, call the Customer Helpline: 08456 400800

Please check you have all the fittings listed below

Note: The quantities below are the correct amount to complete the assembly. In some cases more fittings may be supplied than are required.

A  720mm Threaded stud x 6	B  Plastic cap 16pcs	C  Metal plate threaded 6pcs
--	--	--

Tools required

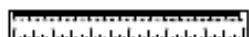

Ruler/tape
measure

Ruler - Use this ruler to help correctly identify the screws

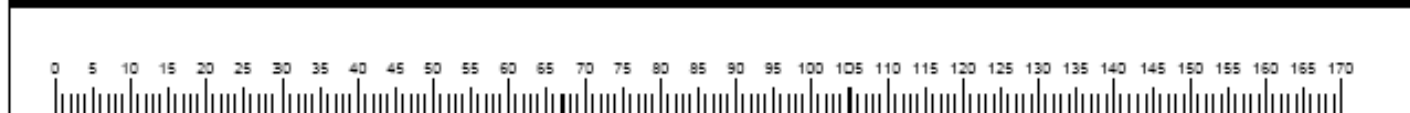

Assembly Instructions

Step 1

Attaching threaded rod



Warning:
With help,
carefully place
glass top **1** upside
down onto a clean flat
surface.

a: Screw threaded rods
A into the metal discs on
the underside of glass
top **1**.

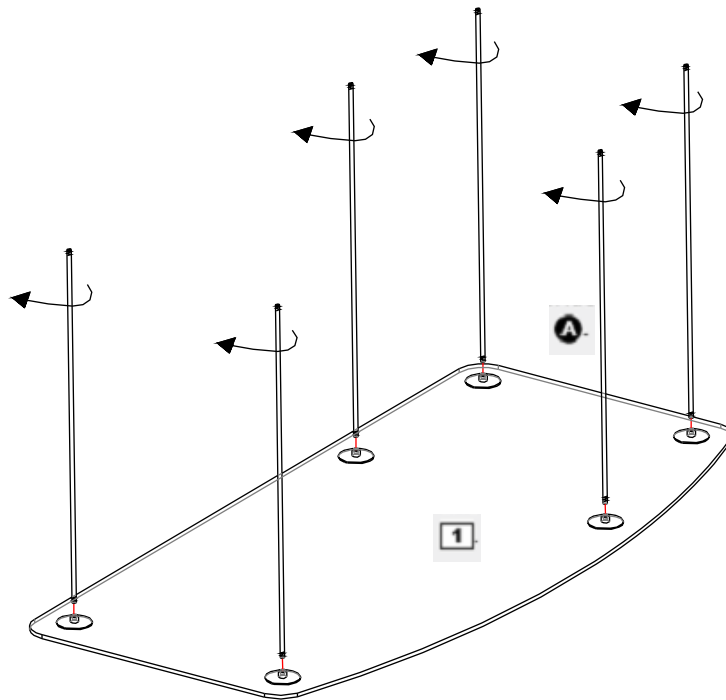

Step 2

Attaching legs

Locate legs **3** over
threaded rods **A** on one
side of top **1**.

Screw metal plates threaded
C into threaded rods **A**

Note: Ensure the metal
plates welded inside the
ends of legs **3** are
facing upwards.

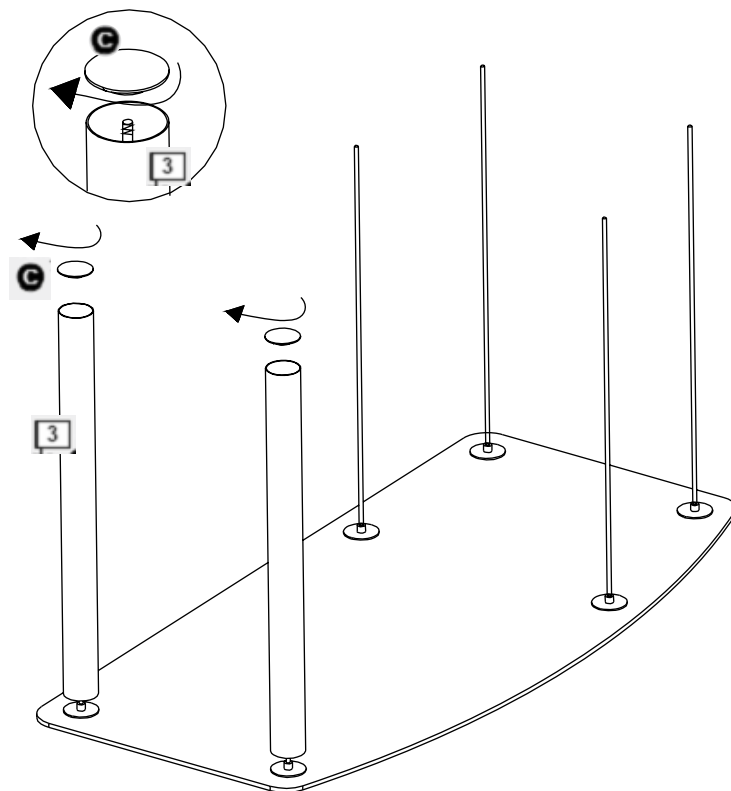

Assembly Instructions

Step 3

Locating middle glass shelf

Locate short supports **4** over threaded rods **A**.

Locate **B** over **4** ensure the plastic cap in the top of support **4** are facing down.

Note: Ensure the plastic caps in the ends of supports **4** are facing up.



Warning: Carefully locate glass shelf **2** over the threaded rods **A**.

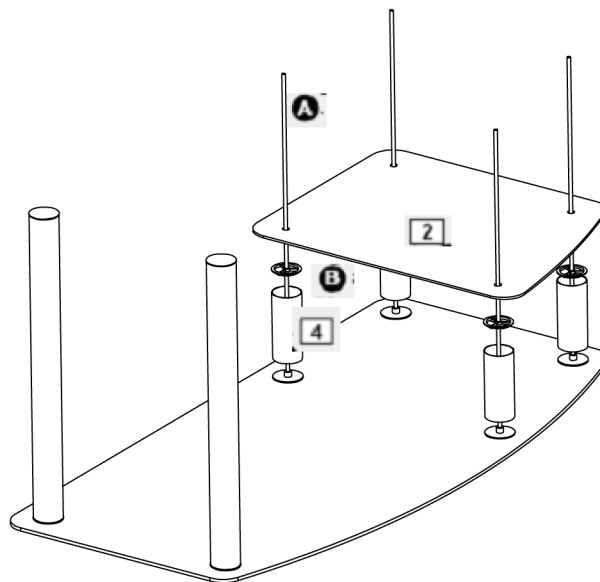

Step 4

Locating lower glass shelf

Locate long supports **5** over threaded rods **A**.

Locate **B** over **5** ensure the plastic cap in the top of support **5** are facing down



Warning: Carefully locate glass shelf **2** over the threaded rods **A**.

Locate **B** over **2** ensure the plastic cap in the top of **2** are facing upwards

Locate feet **6** over the threaded rods **A**.

Screw metal plates threaded **C** into threaded rods **A**.

Note: Ensure the metal plates welded inside the ends of feet **6** are facing upwards.

With help, carefully turn the desk upright.



Warning: The desk is heavy. Lift with care.

Assembly is complete.

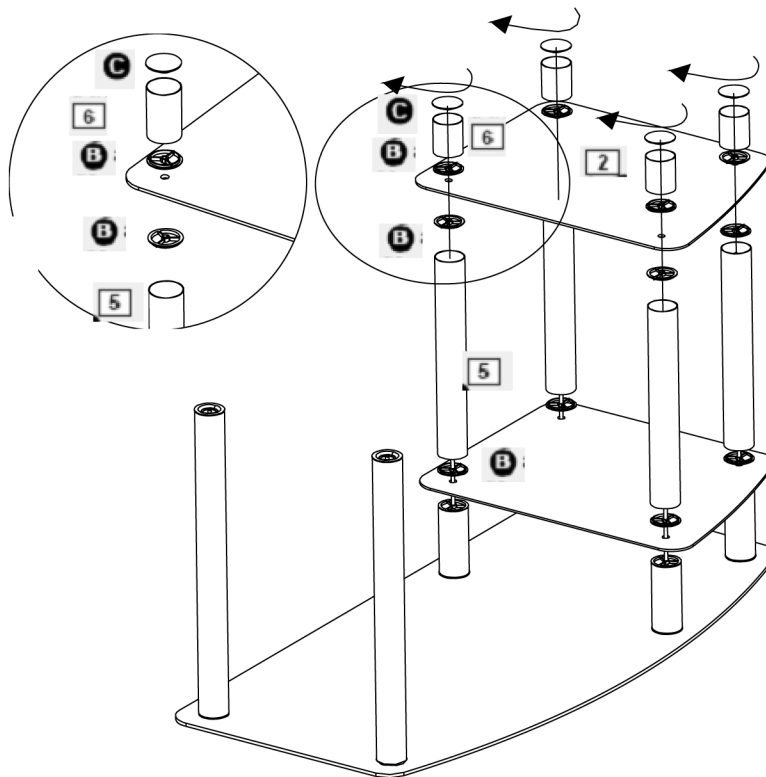

If you need help or have damaged or missing parts, call the **Customer Helpline: 08456 400800**
Home Retail Group, 489-499 Avebury Boulevard, Saxon Gate West, Central Milton Keynes, MK9 2NW