

# Brixham Leather Eff Managers Chair

Assembly Instructions - Please keep for future reference

617/9131

617/3618



## Dimensions

Width-60cm  
Depth-62cm  
Height-92 - 104cm

**Important - Please read these instruction fully before starting assembly**

If you need help or have damaged or missing parts, call the **Customer Helpline: 0845 640 0800**



## Safety and Care Advice

**Important - Please read these instructions fully before starting assembly**

- Check you have all the components and tools listed on pages 2 and 3.

- Remove all fittings from the plastic bags and separate them into their groups.

- Keep children and animals away from the work area, small parts could choke if swallowed.

- Make sure you have enough space to layout the parts before starting.

- Retain these instructions for future reference

- Do not stand or put weight on the product during assembly, this could cause damage.

- Assemble the item as close to its final position (in the same room) as possible.

- Assemble on a soft level surface to avoid damaging the unit or your floor.

- Parts of the assembly will be easier with 2 people.

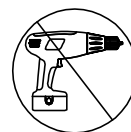

- We do not recommend the use of power drill/drivers **for inserting screws**, as this could damage the unit. Only use hand screwdrivers.

- Dispose of all packaging carefully and responsibly.

- Do not use this item if any components are missing or damaged

### Care and maintenance

- Only clean using a damp cloth and mild detergent, do not use bleach or abrasive cleaners.

- From time to time check that there are no loose screws on this unit.

- This product should not be discarded with household waste. Take to your local authority waste disposal centre.

### Safety during use

- Do not stand on chair. Do not use this chair as a step ladder.

- At least every 4 months, check all bolts, screws and knobs, to be sure they are tight.

- Use this product only for seating one person at a time

- If parts are missing, broken, damaged or worn, stop using this product until repairs are made. Use only factory authorised parts.

- Do not use this chair unless all bolts, screws and knobs are firmly secured.

- Failure to follow these warnings could result in serious injury.

# Components - Parts

If you have damaged or missing components, call the **Customer Helpline: 0845 6400800**

Please check you have all the parts listed below

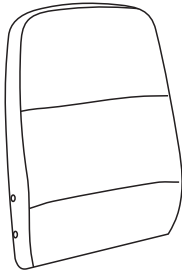

**1** Backrest  
(470x570x65mm)

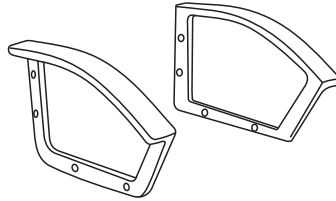

**2** Armrest x2  
(430x250x60mm)

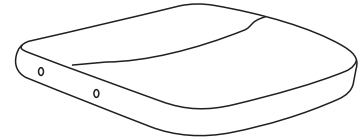

**3** Seat  
(480x485x65mm)

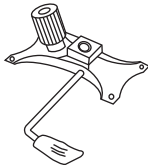

**4** Mechanism  
(248x173mm)

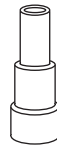

**5** Telescoping cover  
( $\Phi$ 75x320mm)



**6** Gas lift  
( $\Phi$ 50x210mm)

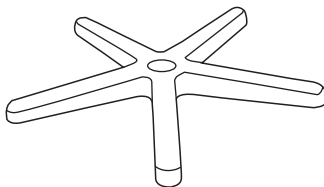

**7** Star base  
(R300mm)

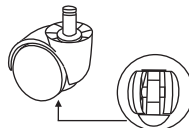

**8** Normal castor x3  
( $\Phi$ 50mm)

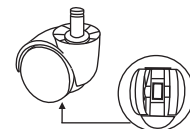



**9** Brake castor x2  
( $\Phi$ 50mm)



# Components - Fittings

Please check you have all the fittings listed below

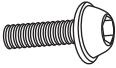
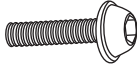
**Note:** The quantities below are the correct amount to complete the assembly. In some cases more fittings may be supplied than are required.

<b>A</b>  M6x16mm bolt x4	<b>B</b>  M6x20mm bolt x8	<b>C</b>  Φ15x9mm cap x8
<b>D</b>  5mm Allen key x1		

## Tools required



Ruler/tape  
measure



**Ruler - Use this ruler to help correctly identify the screws**

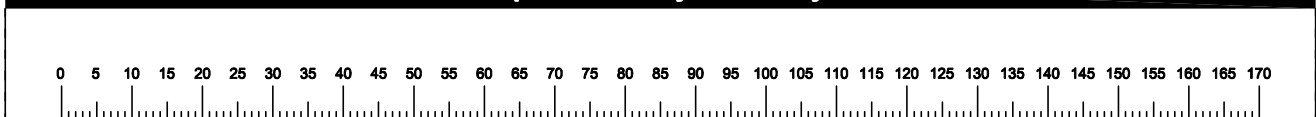

# Assembly Instructions

## Step 1

### Attaching castors

**a:** Insert castors **8** and **9** into star base **7**. Making sure they are in alternate positions on the base.

**b:** Turn star base **7** over and place it on the floor. Insert gas lift **6** into the center hole of star base **7**.

**c:** Place telescoping cover **5** over the gas lift **6**.

**a:**

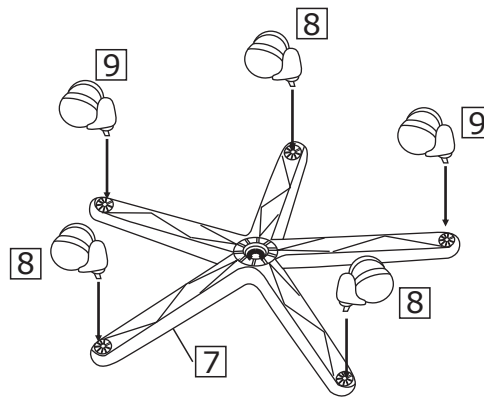

**b:**

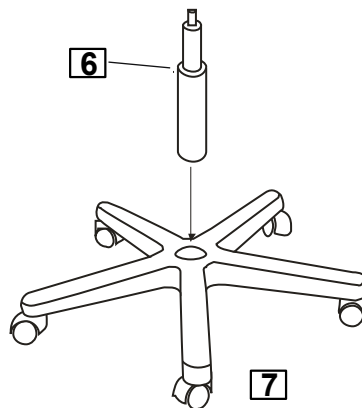

**c:**

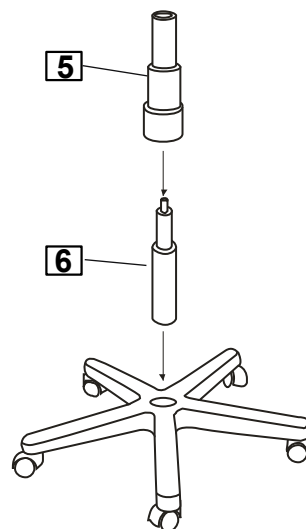

# Assembly Instructions

## Step 2

### Attaching armrests

Attach two armrests **2** to seat **3** with bolts **B** using allen key **D**.

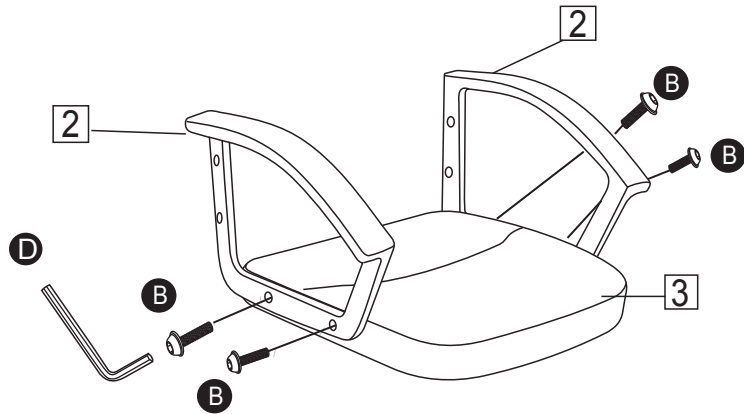

## Step 3

### Assembling the backrest

Assemble armrests **2** to backrest **1** with bolts **B**.

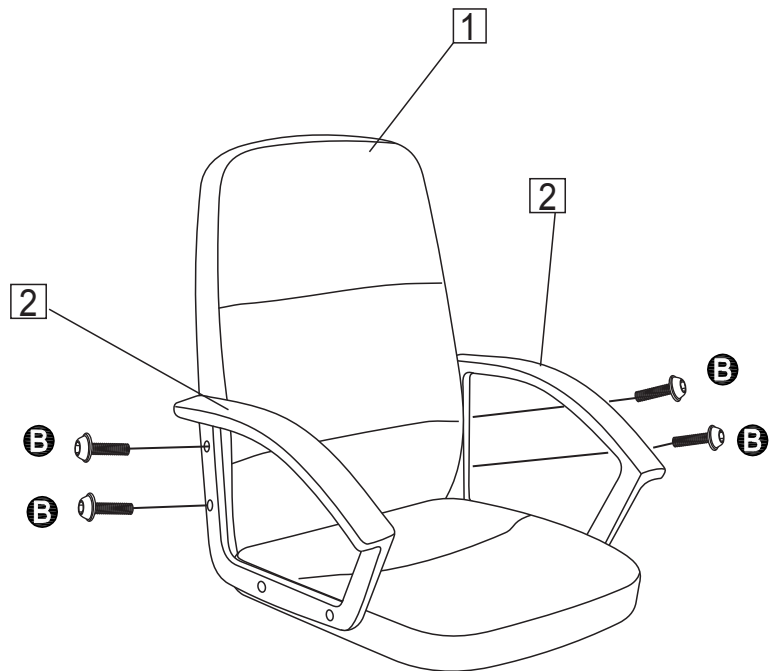

# Assembly Instructions

## Step 4

Use cap **C** to cover the hole of arms **2**.

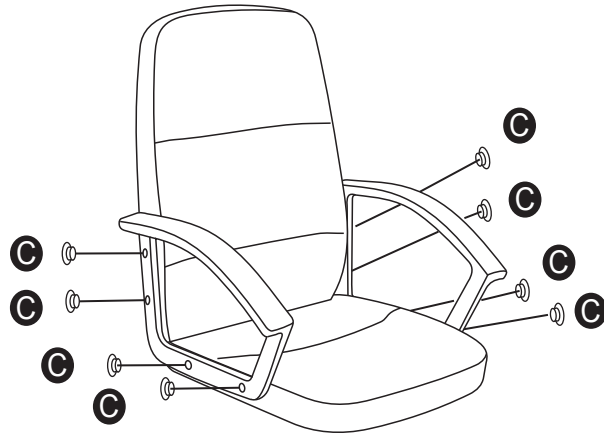

## Step 5

### Attaching mechanism

Attach mechanism **4** to seat **3** with bolts **A**.

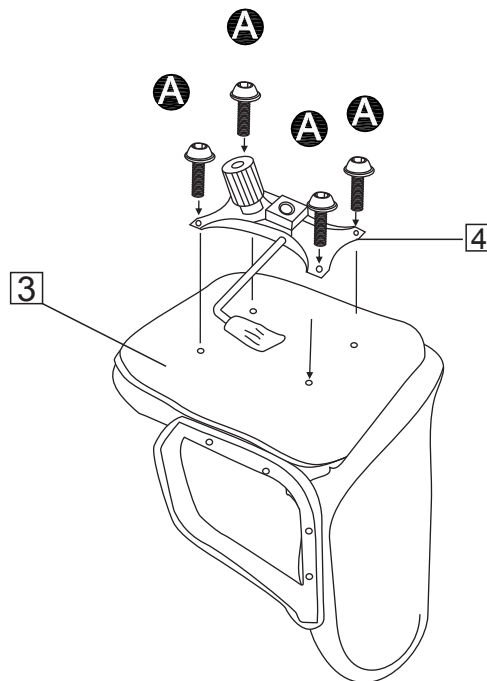

# Assembly Instructions

## Step 6

Place the seat unit onto the top of the gas lift **6**.

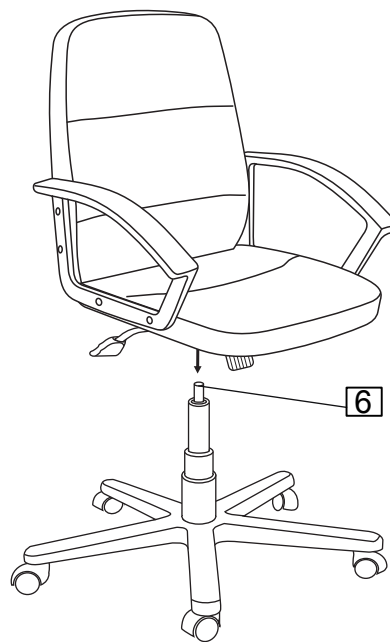

## Step 7

Assembly is complete.





## Components

# Hi Back Leather Mix Manager's Chair

Simple Assembly Instructions - Please keep for future reference

Ⓐ 1 x Backrest

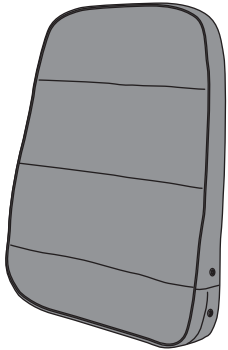

Ⓑ 1 x Seat Cushion

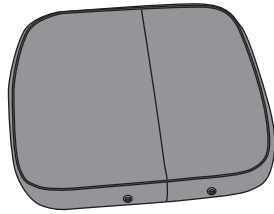

Ⓒ 1 x Left Armrest

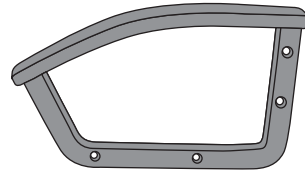

Ⓓ 1 x Right Armrest

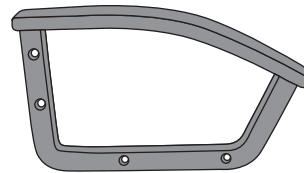

Ⓔ 1 x Base

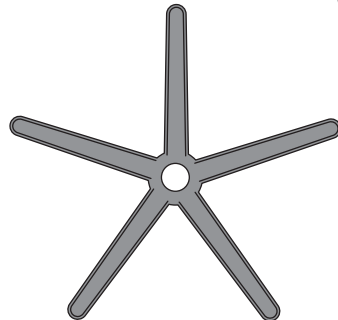

Ⓕ 1 x Seat Support

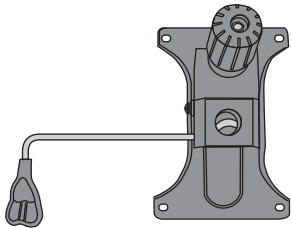

Ⓖ 8 x Plastic Plug



Ⓖ 1 x Gas Lift



Ⓕ 1 x Cover



Ⓖ 5 x Castor

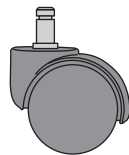

## Fittings

Ⓐ 8 x Long Screw



Ⓑ 4 x Screw



Ⓒ 1 x Hex Key



11-02



## IMPORTANT

1. Read these instructions carefully and familiarise yourself with the procedure before assembling the unit.
2. Check that you have all the component parts following the list on the back cover and familiarise yourself with each part before proceeding.
3. Take all the fittings out of the plastic bag and separate them into their groups.
4. Ensure you have enough space to lay out all the parts before assembly.
5. To avoid scratching it is recommended that you assemble the unit on a soft level surface.

# Assembly Instructions

## Stage 1 – The Base

1. Place all the five Castors **J** in the holes located under Base **E**. See fig. 1.

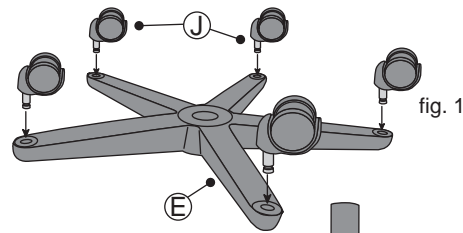

2. Put Gas Lift **G** in the Base unit. Then slide the Cover **H** over the top. See fig. 2.

**NOTE: Make sure the Metal Support is fixed tight and is fully inserted.**

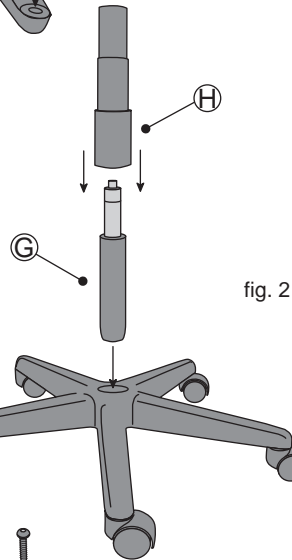

## Stage 2 - The Seat Cushion

1. Use the Screw **B** to fix the Seat Support **D** into the Seat Cushion **B**. See fig. 3.

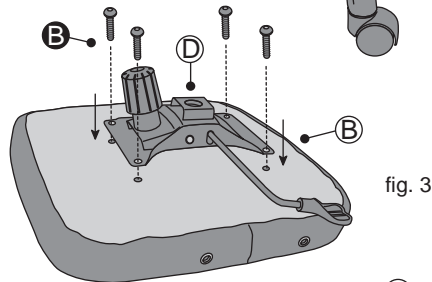

2. Use the Screw **A** to fix the Left Armrest **C** and Right Armrest **F** into the Seat Cushion. Then use Plastic Plug **I** to cover the Screws. See fig. 4.

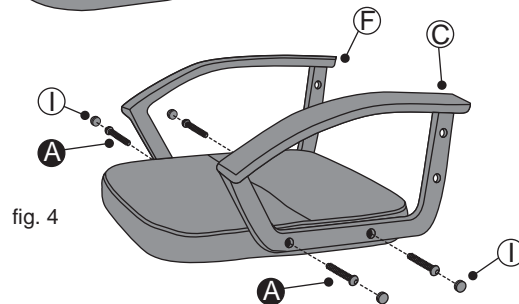

# Assembly Instructions

## Stage 3 – Finishing the Unit

1. Use the Screw **A** to fix the Backrest **A** in the Armrest. Then use the Plastic Plug **I** to cover the Screws. See fig. 5.

**NOTE: It would be useful to ask someone to help you at this stage.**

2. Put the Seat Cushion onto the Base Unit. See fig. 6.

**NOTE: This part can no longer be disassembled.**

3. Finally carefully place the chair in the desired location. See fig. 7.



## Care and Maintenance

### Safety

To avoid any risk of suffocation to animals or children dispose of the plastic bags immediately.

### Cleaning

As with all surfaces clean with a damp cloth and mild detergent, do not use bleach or abrasive products.

### Fitting

From time to time check to ensure the screws are ridged.

## Components

# Mid Back Leather Manager's Chair

Simple Assembly Instructions - Please keep for future reference

Ⓐ 1 x Backrest

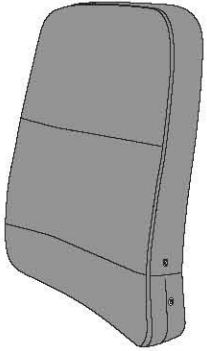

Ⓑ 1 x Seat Cushion

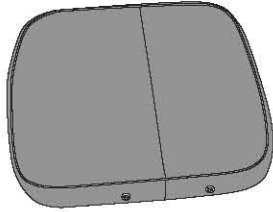

Ⓒ 1 x Left Armrest

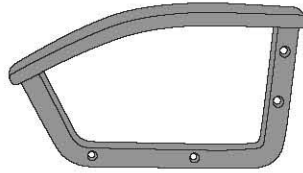

Ⓓ 1 x Right Armrest

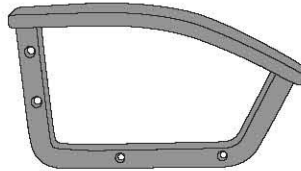

Ⓔ 1 x Base

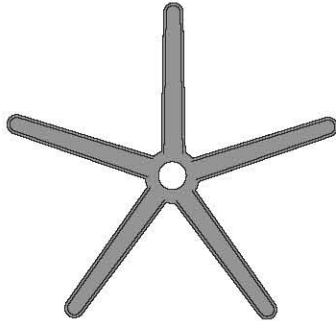

Ⓖ 1 x Seat Support

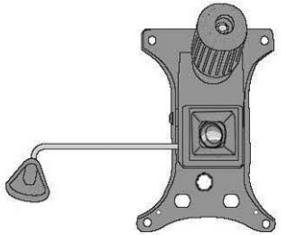

Ⓛ 8 x Plastic Plug



Ⓜ 1 x Gas Lift



Ⓝ 1 x Cover



Ⓚ 5 x Caster

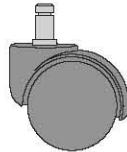

## Fittings

Ⓐ 12X Bolt



Ⓑ 4x Washer



Ⓒ 1 x Tool



## IMPORTANT

1. Read these instructions carefully and familiarise yourself with the procedure before assembling the unit.
2. Check that you have all the component parts following the list on the back cover and familiarise yourself with each part before proceeding.
3. Take all the fittings out of the plastic bag and separate them into their groups.
4. Ensure you have enough space to lay out all the parts before assembly.
5. To avoid scratching it is recommended that you assemble the unit on a soft level surface.

# Assembly Instructions

## Stage 1 – The Base

1. Place all the five Casters **J** in the holes located under Base **E**. See fig. 1.

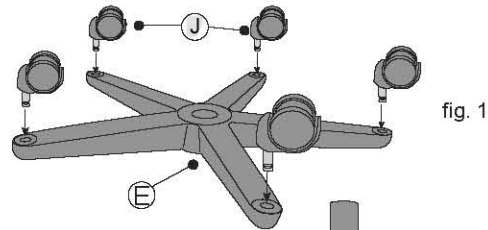

fig. 1

2. Put Gas Lift **G** in the Base unit. Then slide Cover **H** over the unit. See fig. 2.

**NOTE: Make sure the Metal Support is fix in the Base tightly.**

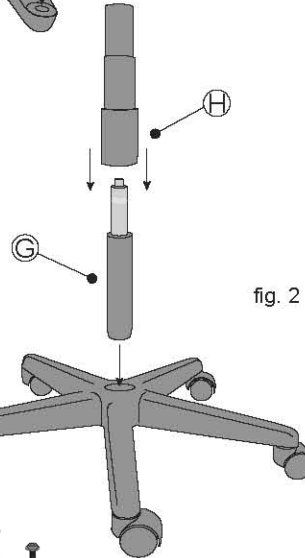

fig. 2

## Stage 2 - The Seat Cushion

1. Use Bolts **A** and Washers **B** to fix the Seat Support **D** into the Seat Cushion **B**. See fig. 3.

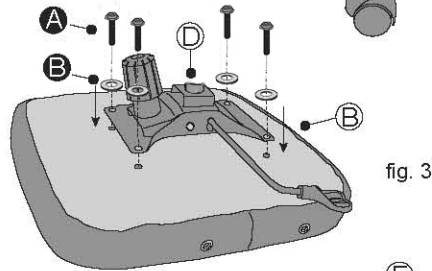

fig. 3

2. Use Bolts **A** to fix the Left Armrest **C** and Right Armrest **F** into the Seat Cushion. Then use Plastic Plug **I** to cover the Bolts. See fig. 4.

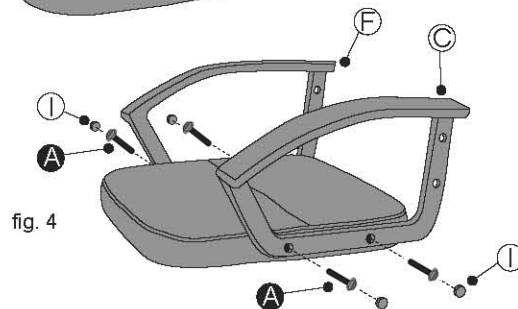

fig. 4

# Assembly Instructions

## Stage 3 – Finishing the Unit

1. Use the Screw **A** to fix the Backrest **A** in the Armrest. Then use the Plastic Plug **I** to cover the Screws. See fig. 5.

**NOTE: It would be useful to ask someone to help you at this stage.**

2. Put the Seat Cushion onto the Base Unit. See fig. 6.

**NOTE: This part can no longer be disassembled.**

3. Finally carefully place the chair in the desired location. See fig. 7.

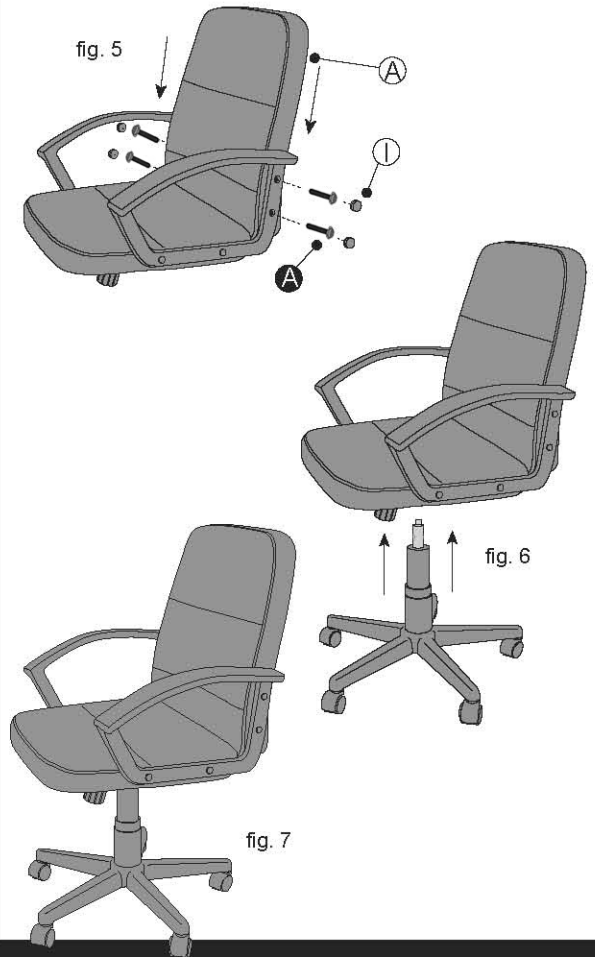

fig. 5



fig. 6



fig. 7

## Care and Maintenance

### Safety

To avoid any risk of suffocation to animals or children dispose of the plastic bags immediately.

### Cleaning

As with all surfaces clean with a damp cloth and mild detergent, do not use bleach or abrasive products.

### Fitting

From time to time check to ensure the screws are ridged.