

Malibu - Corner Desk

Assembly Instructions - Please keep for future reference

621/3310

621/3327

617/3223

617/3230

617/3900

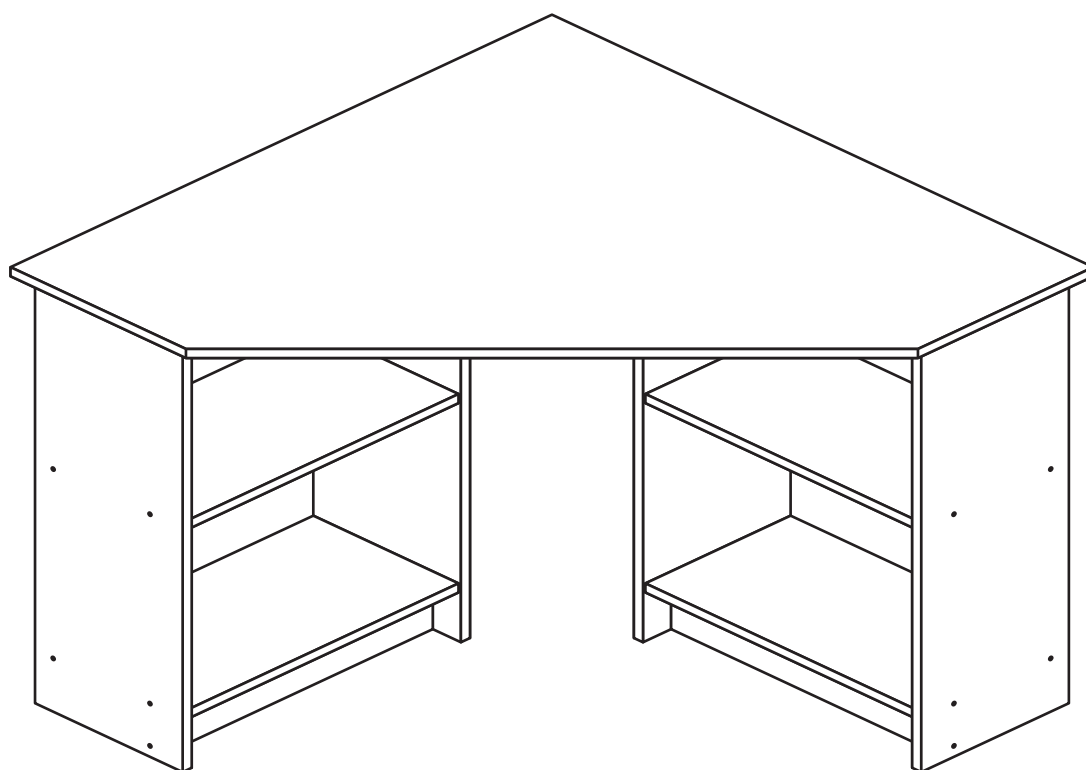

Dimensions

Width - 89.5cm

Depth - 89.5cm

Height - 72cm



**MADE IN
BRITAIN**

Important - Please read these instructions fully before starting assembly

If you need help or have damaged or missing parts, call the **Customer Helpline: 08456 400800**



Safety and Care Advice

Important - Please read these instructions fully before starting assembly

- **Warning:** This unit weighs approximately 19kgs. Please lift with care.

- Check you have all the components and tools listed on pages 2 and 3.

- Remove all fittings from the plastic bags and separate them into their groups.

- Keep children and animals away from the work area, small parts could choke if swallowed.

- Parts of the assembly will be easier with 2 people.

- Make sure you have enough space to layout the parts before starting.

- Do not stand or put weight on the product, this could cause damage.

- Assemble the item as close to its final position (in the same room) as possible.

- Assemble on a soft level surface to avoid damaging the unit or your floor (use opened out unit carton).



- We do not recommend the use of power drill/drivers **for inserting screws**, as this could damage the unit. Only use hand screwdrivers.

- **Safety note:** It is recommended that this unit is secured to a wall using the bracket supplied.

- Dispose of all packaging carefully and responsibly.

Care and maintenance

- Only clean using a damp cloth and mild detergent, do not use bleach or abrasive cleaners.

- From time to time check that there are no loose screws on this unit.

- This product should not be discarded with household waste. Take to your local authority waste disposal centre.

Note: If required the next page can be cut out and used as reference throughout the assembly. Keep this page with these instructions for future reference.

Components - Panels

If you have damaged or missing components, call the **Customer Helpline: 08456 400800** quoting the reference numbers below

Please check you have all the panels listed below

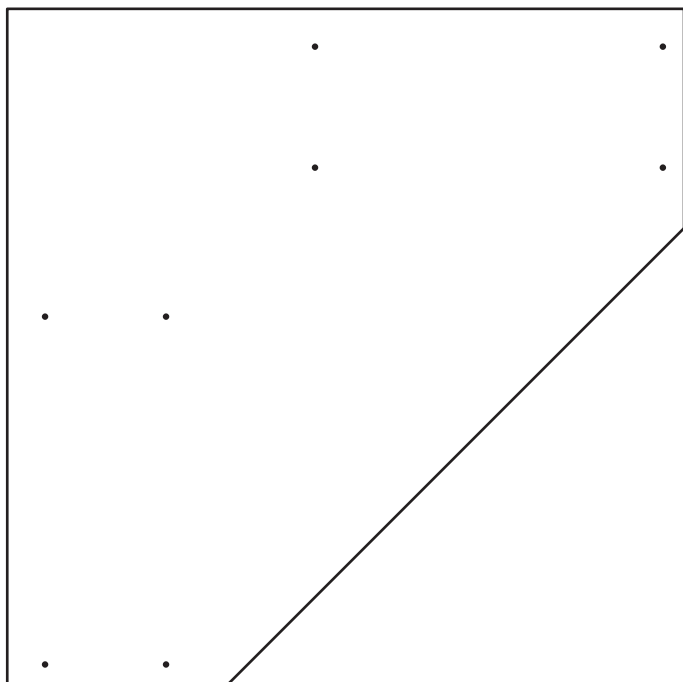

1 Top (D0872A)
(895 x 895mm)

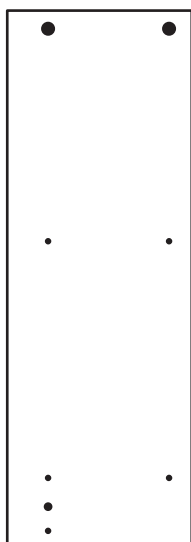

2 Left Side (D0873A)
(706 x 244mm) x 2

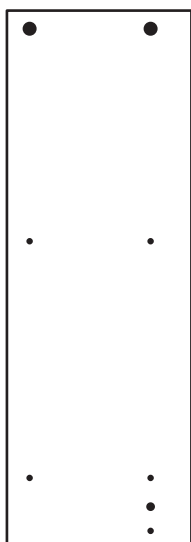

3 Right Side (D0874A)
(706 x 244mm) x 2



4 Plinth (D0875A)
(445 x 80mm) x 2



5 Shelf (D0876A)
(445 x 240mm) x 4







Components - Fittings

If you have damaged or missing components, call the **Customer Helpline: 08456 400800** quoting the reference numbers below

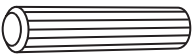
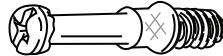
Please check you have all the fittings listed below

Note: The quantities below are the correct amount to complete the assembly. In some cases more fittings may be supplied than are required.

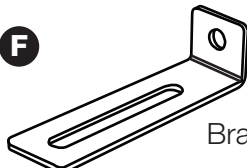
<p>A </p> <p>Wooden dowel (F22) x 4</p>	<p>B </p> <p>Metal dowel (F901) x 8</p>	<p>C </p> <p>Large locking nut (F900) x 8</p>
<p>D </p> <p>40mm Screw (F910) x 20</p>	<p>E </p> <p>13mm Screw (F79) x 1</p>	<p>F </p> <p>Bracket (F327) x 1</p>

Tools required



Rule



Cross-head screwdriver



Scissors



Hammer



Eye protection (when using a hammer or drill)



Electric drill (only use when drilling into walls)

Ruler - Use this ruler to help correctly identify the screws

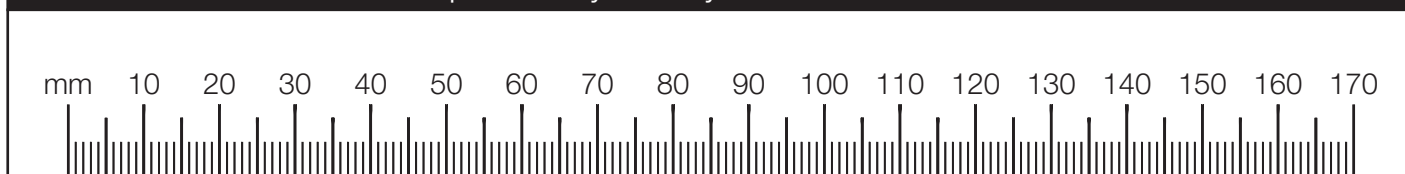

Assembly Instructions

If you have damaged or missing components, call the
Customer Helpline: 08456 400800 quoting the reference
numbers below

Step 1

Prepare the 2 left sides

Insert 2 large locking nuts **C** into each of the left sides **2**.

Note: The arrow on the locking nut **must** point towards the hole in the edge of the panel.

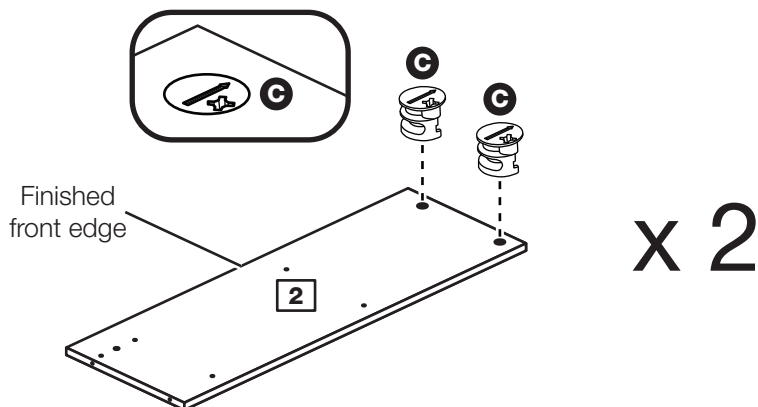

Step 2

Prepare the 2 right sides

Insert 2 large locking nuts **C** into each of the right sides **3**.

Note: The arrow on the locking nut **must** point towards the hole in the edge of the panel.

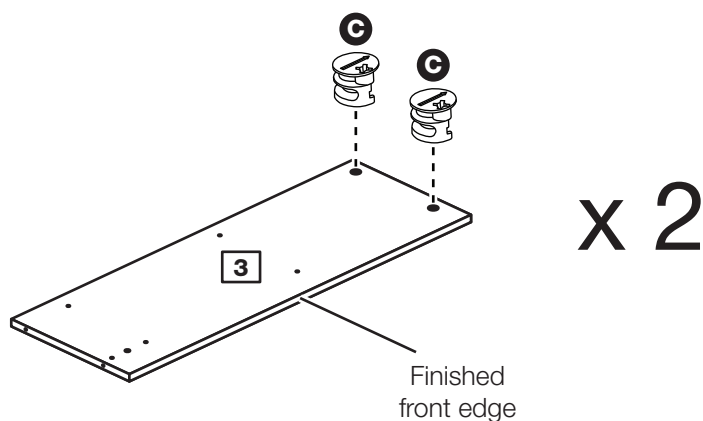

Step 3

Join the left side and shelves

Position 2 shelves **5** against each of the left sides **2** as shown and secure with 4 screws **D**.

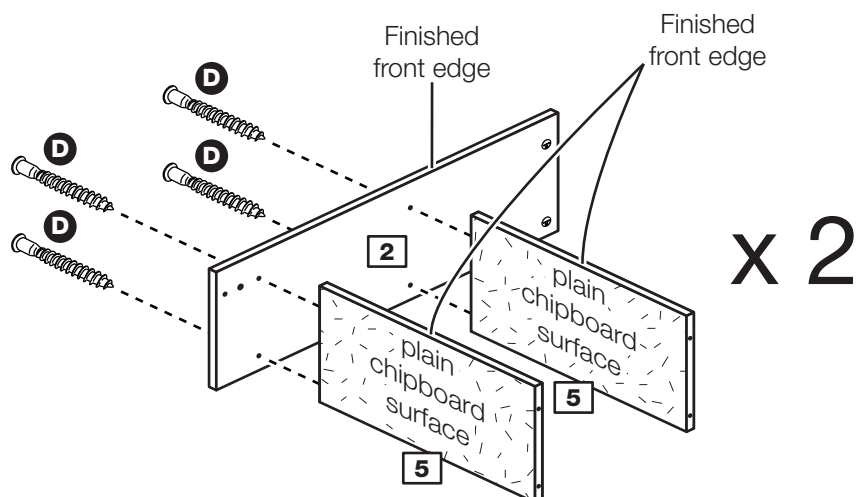

Assembly Instructions

Step 4

Prepare the plinths

Tap 2 wooden dowels **A** into each plinth **4**.

Note: Wooden dowels **must not** stick out from the edge by more than 10mm or they may damage other panels.

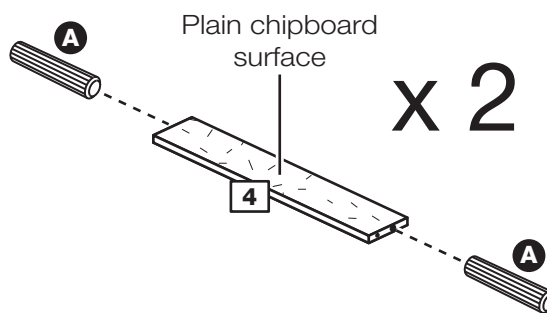

Step 5

Fit the plinths

Push a plinth **4** onto each left side **2** as shown and secure with screw **D**.

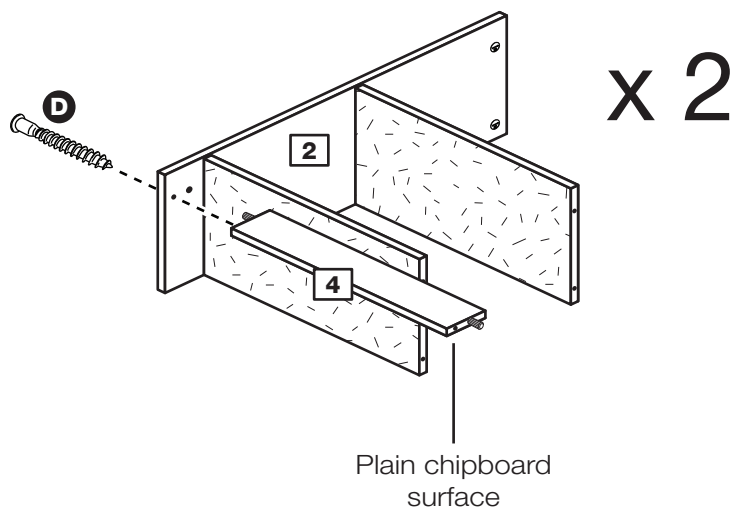

Step 6

Fit the right sides

Push a right side **3** onto each assembly as shown and secure with 5 screws **D**.

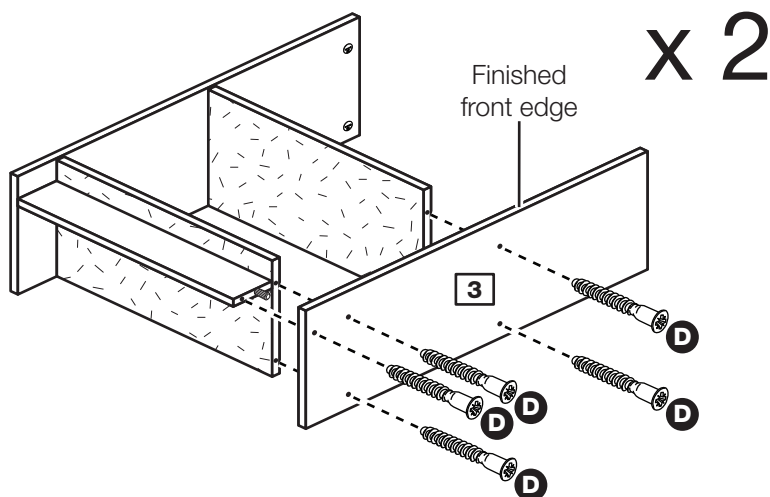

Assembly Instructions

Step 7

Prepare the top

Screw 8 metal dowels **B** into the top **1**.

Note: Tighten metal dowels up fully against the panels.

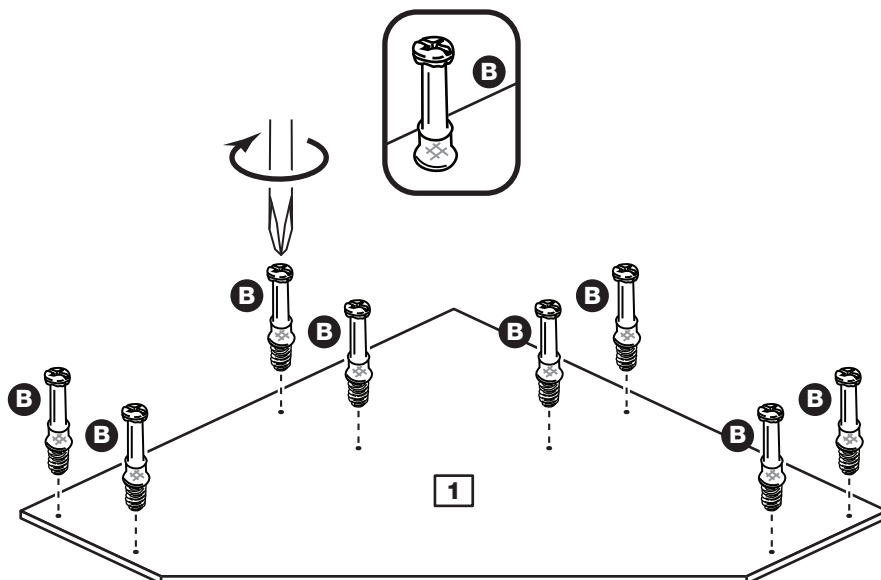

Step 8

Fit the top

Push the 2 shelf assemblies down onto the top **1**.

Use a screwdriver to tighten the 8 large locking nuts **C** fitted to the inside of the side panels **2** and **3**.

Note: Turn the large locking nuts **C** as far as they will go - more than 1/2 a turn.

Carefully turn the desk the correct way up



Warning: The unit is heavy. Lift with care.

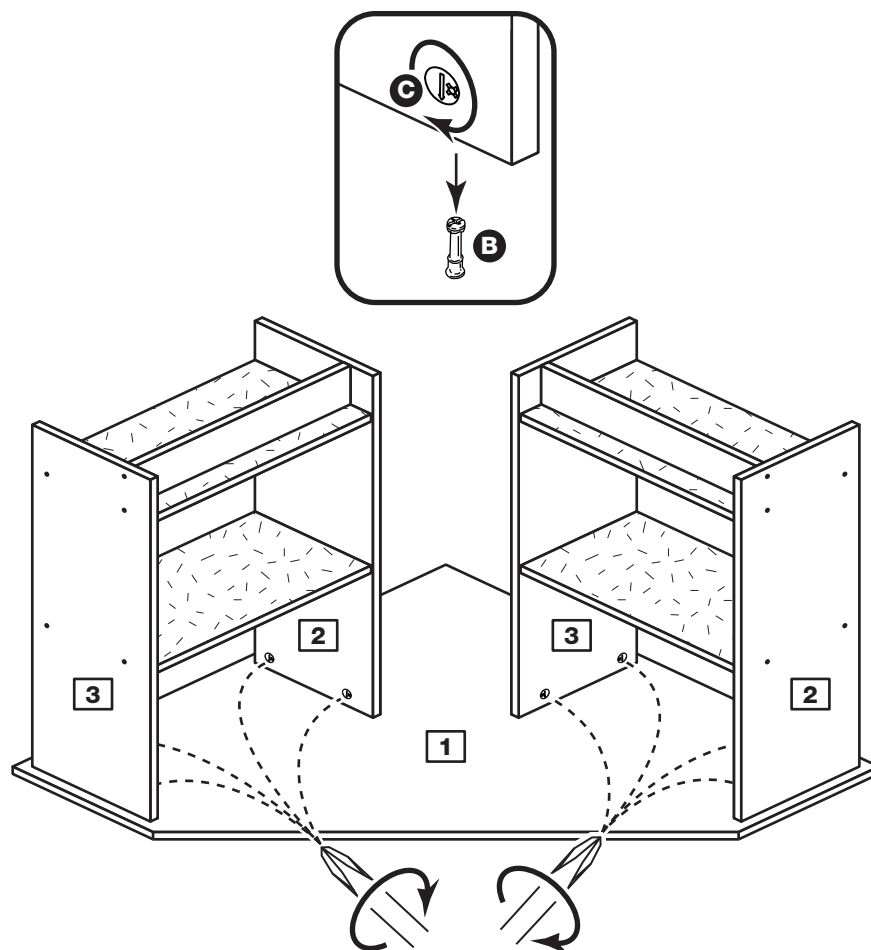

Assembly Instructions

Step 9

Fit the bracket

To prevent possible overbalancing, we recommend that this unit is secured to a suitable wall by use of the bracket **F** fitted underneath the top **1**.

Fixings are not supplied, as they will need to suit the wall type and the length of screw will depend on the distance from the back edge of the unit to the wall.

Place the desk in its final position.

Fix the bracket **F** underneath the top **1** of the unit, flush to the back edge that is against the wall, using screw **E**.

Note: Take care when drilling the wall that you do not drill into any pipes, wires etc. If in doubt, consult an expert.



Warning: The unit is heavy. Lift with care.

Assembly is complete

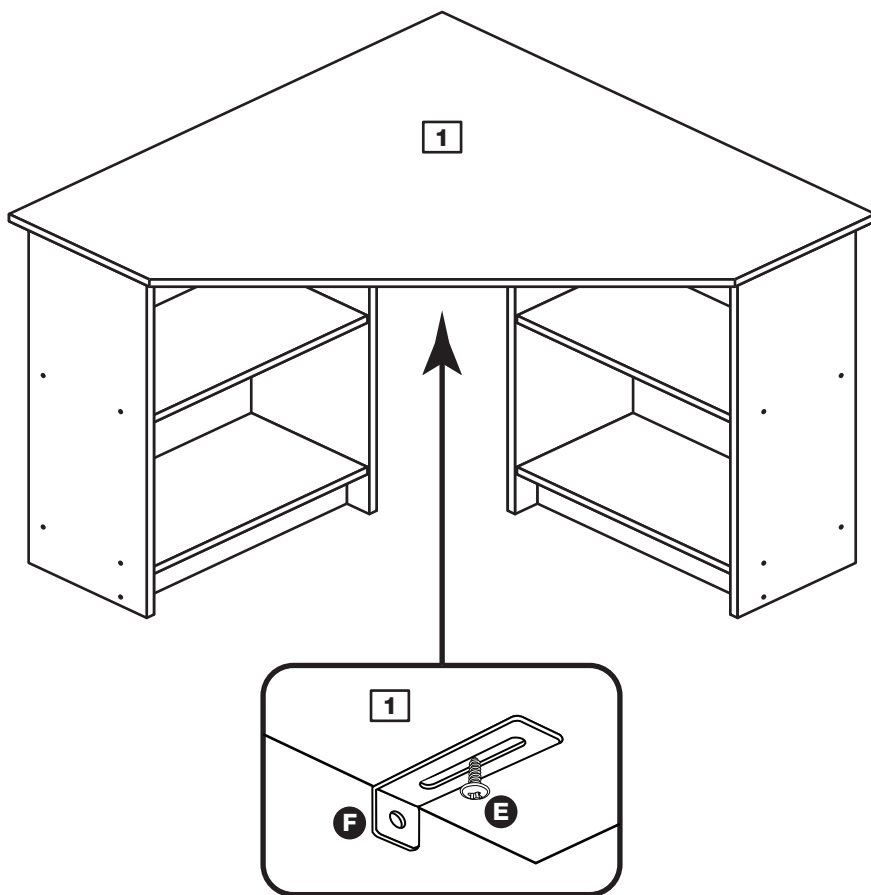

This shows the bracket being fitted to the back edge on the left side of the top. You may fit it in a different position to suit your requirements.

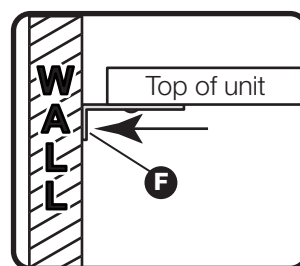

If you need help or have damaged or missing parts, call the **Customer Helpline: 08456 400800** and quote the reference numbers on the component pages.

Argos Ltd, 489-499 Avebury Boulevard, Central Milton Keynes, MK9 2NW

Malibu - Corner Desk

Assembly Instructions - Please keep for future reference

621/3310

621/3327

617/3223

617/3230

617/3900

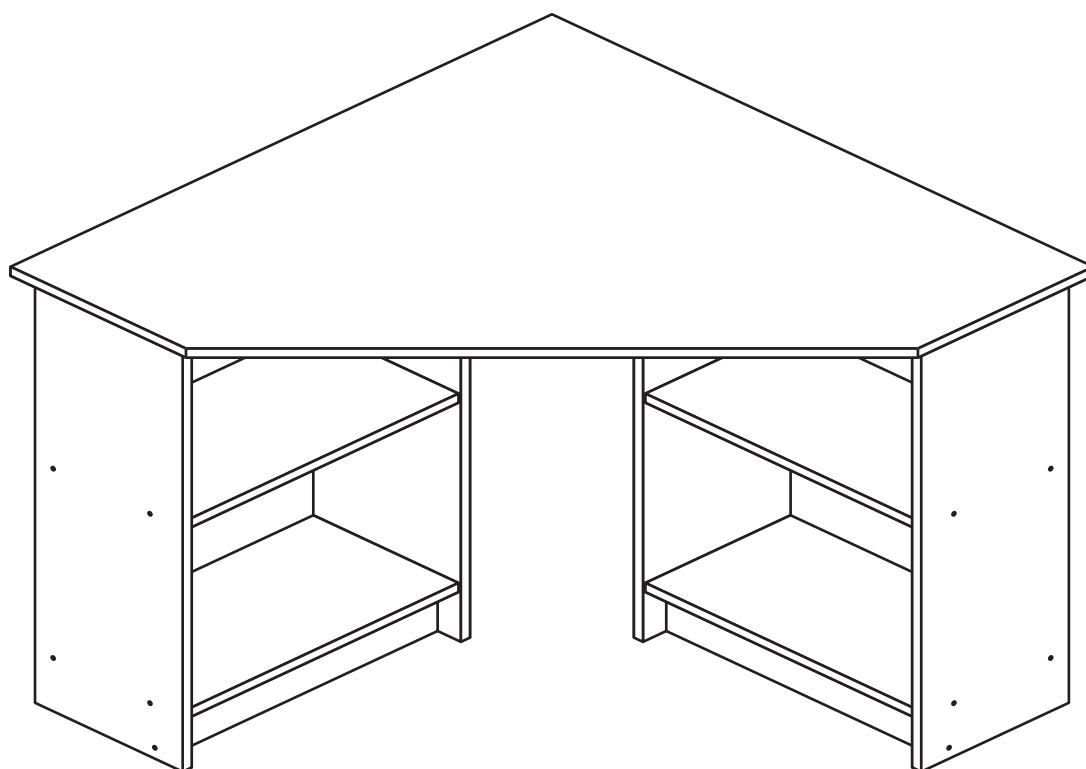

Dimensions

Width - 89.5cm

Depth - 89.5cm

Height - 72cm



**MADE IN
BRITAIN**

Important - Please read these instructions fully before starting assembly

If you need help or have damaged or missing parts, call the **Customer Helpline: 08456 400800**



Safety and Care Advice

Important - Please read these instructions fully before starting assembly

- **Warning:** This unit weighs approximately 19kgs. Please lift with care.

- Check you have all the components and tools listed on pages 2 and 3.

- Remove all fittings from the plastic bags and separate them into their groups.

- Keep children and animals away from the work area, small parts could choke if swallowed.

- Parts of the assembly will be easier with 2 people.

- Make sure you have enough space to layout the parts before starting.

- Do not stand or put weight on the product, this could cause damage.

- Assemble the item as close to its final position (in the same room) as possible.

- Assemble on a soft level surface to avoid damaging the unit or your floor (use opened out unit carton).



- We do not recommend the use of power drill/drivers **for inserting screws**, as this could damage the unit. Only use hand screwdrivers.

- **Safety note:** It is recommended that this unit is secured to a wall using the bracket supplied.

- Dispose of all packaging carefully and responsibly.

Care and maintenance

- Only clean using a damp cloth and mild detergent, do not use bleach or abrasive cleaners.

- From time to time check that there are no loose screws on this unit.

- This product should not be discarded with household waste. Take to your local authority waste disposal centre.

Note: If required the next page can be cut out and used as reference throughout the assembly. Keep this page with these instructions for future reference.

Components - Panels

If you have damaged or missing components, call the **Customer Helpline: 08456 400800** quoting the reference numbers below

Please check you have all the panels listed below

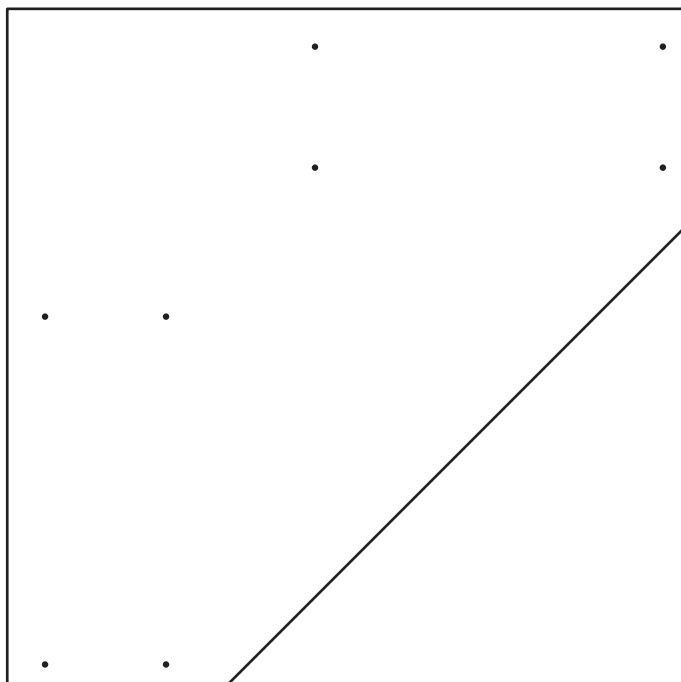

1 Top (D2827A)
(895 x 895mm)

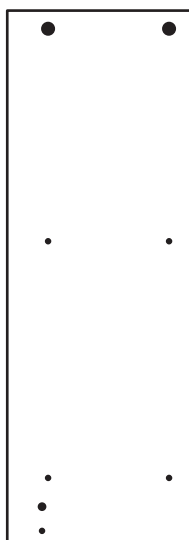

2 Left Side (D2828A)
(706 x 244mm) x 2

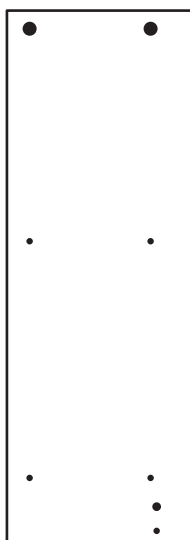

3 Right Side (D2829A)
(706 x 244mm) x 2



4 Plinth (D2830A)
(445 x 80mm) x 2

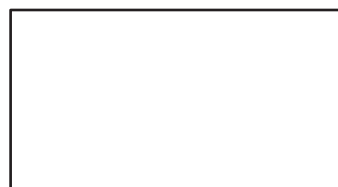

5 Shelf (D2831A)
(445 x 240mm) x 4







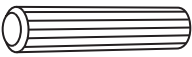
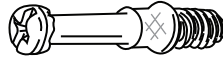

Components - Fittings

If you have damaged or missing components, call the **Customer Helpline: 08456 400800** quoting the reference numbers below

Please check you have all the fittings listed below

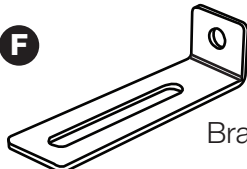
Note: The quantities below are the correct amount to complete the assembly. In some cases more fittings may be supplied than are required.

<p>A </p> <p>Wooden dowel (F22) x 4</p>	<p>B </p> <p>Metal dowel (F901) x 8</p>	<p>C </p> <p>Large locking nut (F900) x 8</p>
<p>D </p> <p>40mm Screw (F910) x 20</p>	<p>E </p> <p>13mm Screw (F79) x 1</p>	<p>F </p> <p>Bracket (F327) x 1</p>
<p>G </p> <p>Plastic Nail (F91) x 8</p>		

Tools required



Rule



Cross-head screwdriver



Scissors



Hammer



Eye protection (when using a hammer or drill)



Electric drill (only use when drilling into walls)

Ruler - Use this ruler to help correctly identify the screws

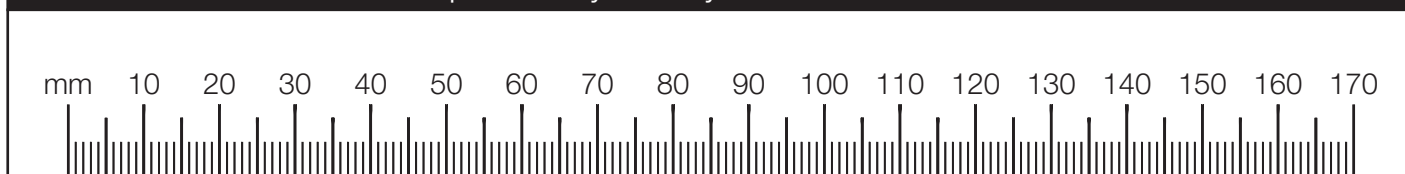

Assembly Instructions

If you have damaged or missing components, call the
Customer Helpline: 08456 400800 quoting the reference
numbers below

Step 1

Prepare the 2 left sides

Insert 2 large locking nuts **C** into each of the left sides **2**.

Note: The arrow on the locking nut **must** point towards the hole in the edge of the panel.

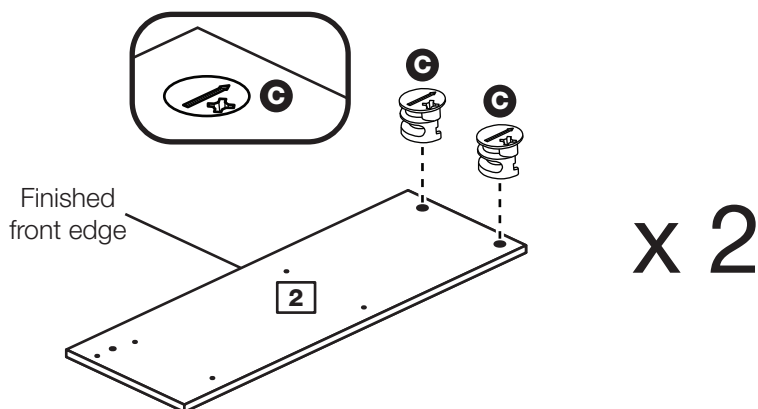

Step 2

Prepare the 2 right sides

Insert 2 large locking nuts **C** into each of the right sides **3**.

Note: The arrow on the locking nut **must** point towards the hole in the edge of the panel.

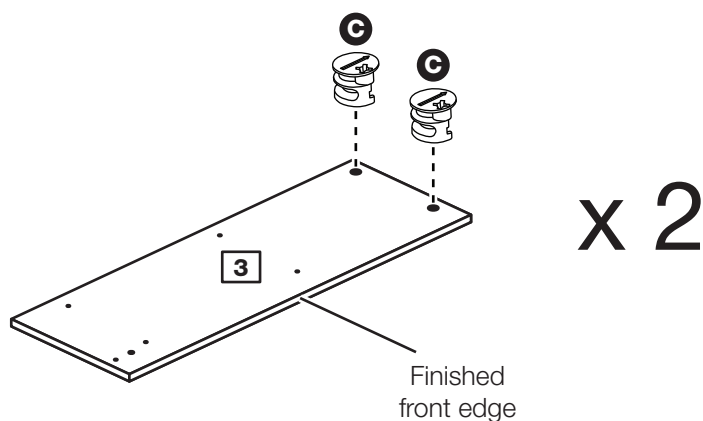

Step 3

Join the left side and shelves

Position 2 shelves **5** against each of the left sides **2** as shown and secure with 4 screws **D**.

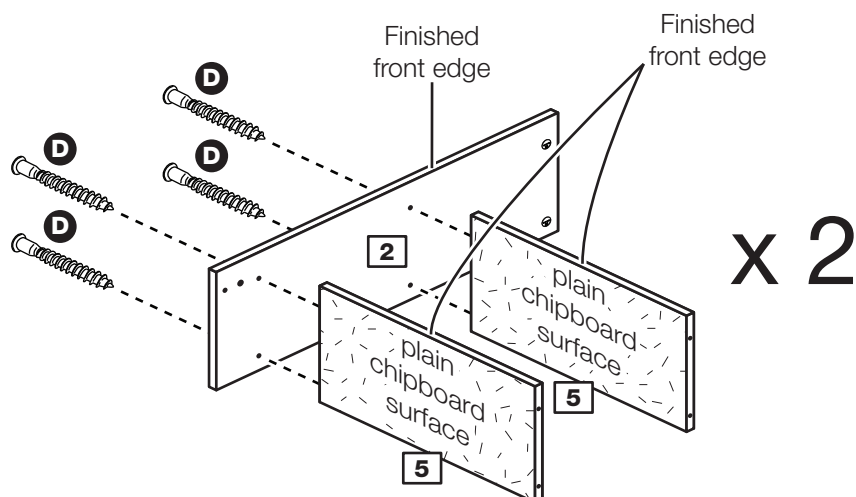

Assembly Instructions

Step 4

Prepare the plinths

Tap 2 wooden dowels **A** into each plinth **4**.

Note: Wooden dowels **must not** stick out from the edge by more than 10mm or they may damage other panels.

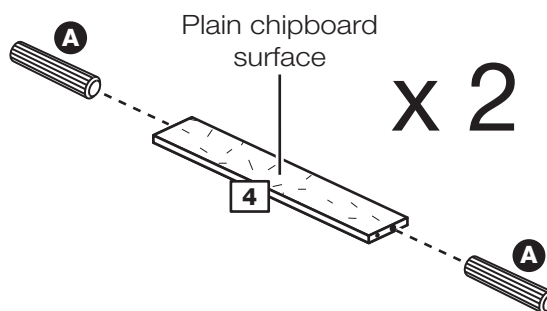

Step 5

Fit the plinths

Push a plinth **4** onto each left side **2** as shown and secure with screw **D**.

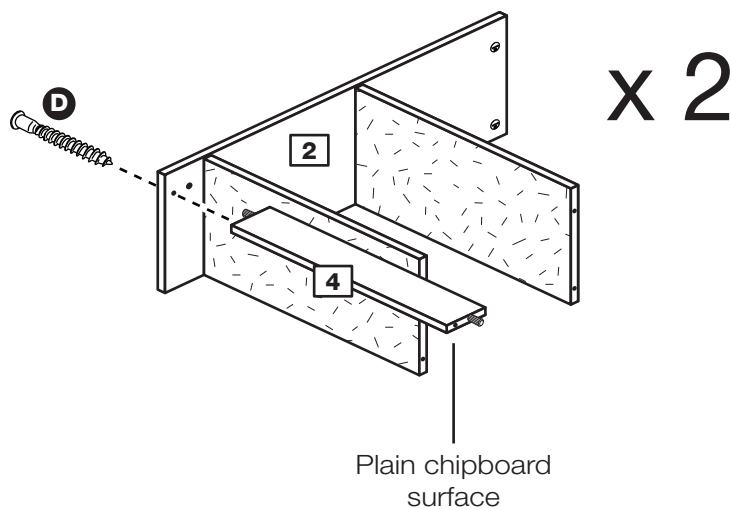

Step 6

Fit the right sides

Push a right side **3** onto each assembly as shown and secure with 5 screws **D**.

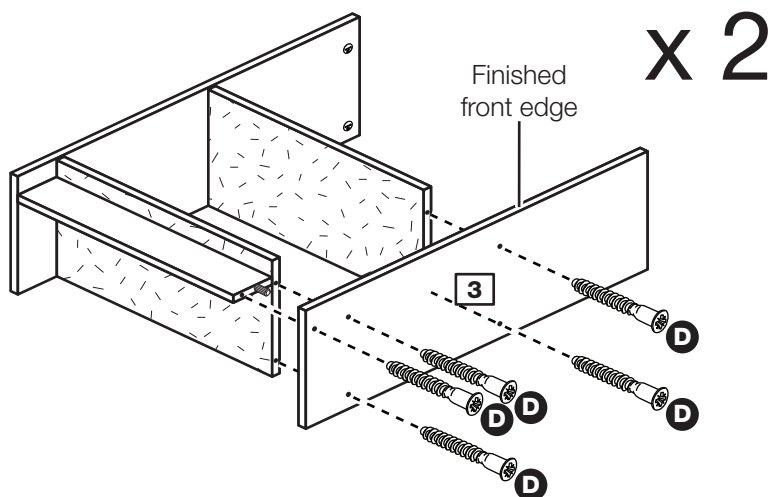

Assembly Instructions

Step 7

Prepare the top

Screw 8 metal dowels **B** into the top **1**.

Note: Tighten the metal dowels up fully against the panel.

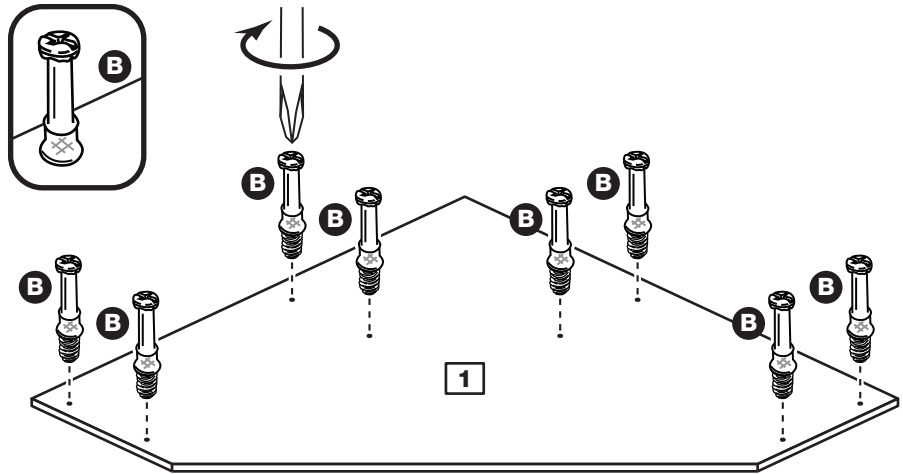

Step 8

Fit the top and fit the plastinails

Push the 2 shelf assemblies down onto the top **1**.

Use a screwdriver to tighten the 8 large locking nuts **G** fitted to the inside of the side panels **2** and **3**.

Note: Turn the large locking nuts **G** as far as they will go - more than 1/2 a turn.

Tap 2 plastic nails **G** into the bottom edge of each of the side panels **2** and **3**.

Carefully turn the desk the correct way up

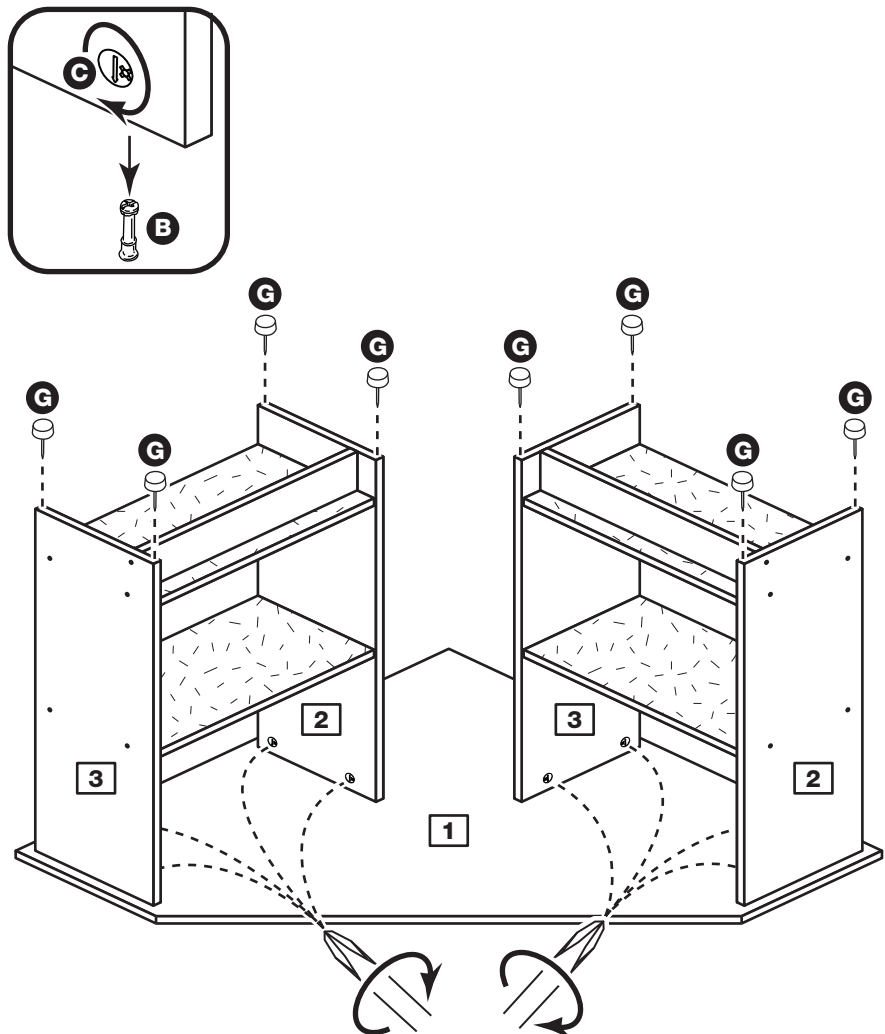

Warning: The unit is heavy. Lift with care.

Assembly Instructions

Step 9

Fit the bracket

To prevent possible overbalancing, we recommend that this unit is secured to a suitable wall by use of the bracket **F** fitted underneath the top **1**.

Fixings are not supplied, as they will need to suit the wall type and the length of screw will depend on the distance from the back edge of the unit to the wall.

Place the desk in its final position.

Fix the bracket **F** underneath the top **1** of the unit, flush to the back edge that is against the wall, using screw **E**.

Note: Take care when drilling the wall that you do not drill into any pipes, wires etc. If in doubt, consult an expert.



Warning: The unit is heavy. Lift with care.

Assembly is complete

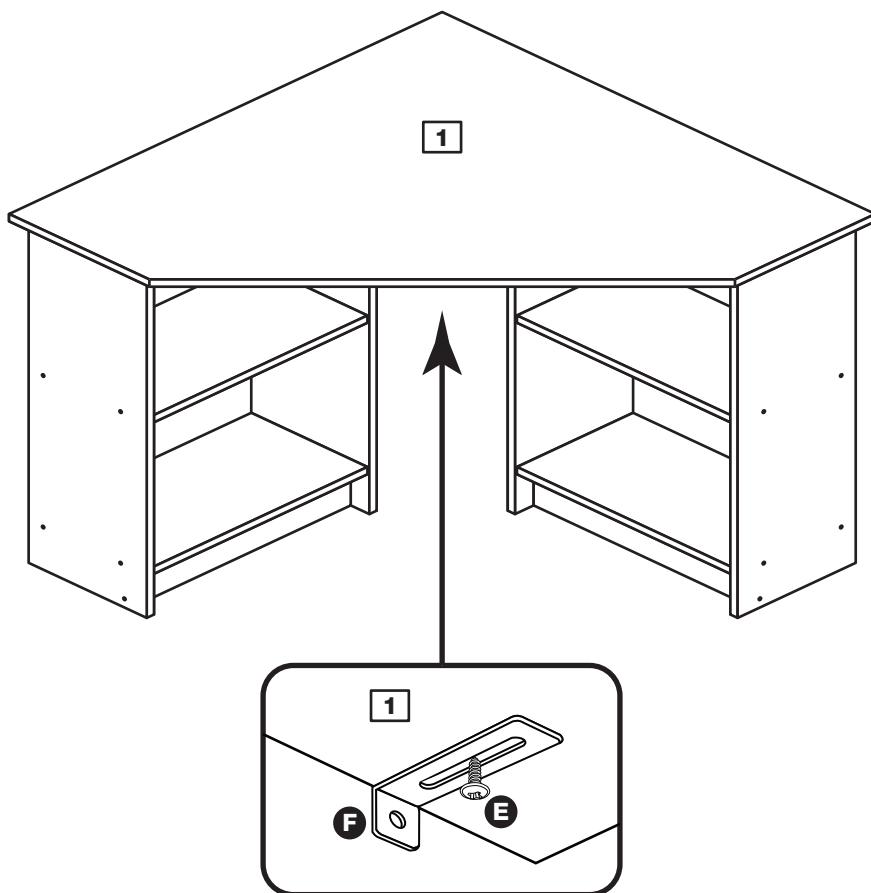

This shows the bracket being fitted to the back edge on the left side of the top. You may fit it in a different position to suit your requirements.

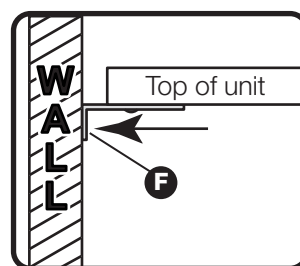

If you need help or have damaged or missing parts, call the **Customer Helpline: 08456 400800** and quote the reference numbers on the component pages.

Argos Ltd, 489-499 Avebury Boulevard, Central Milton Keynes, MK9 2NW

Malibu - Corner Desk

Assembly Instructions - Please keep for future reference

621/3310

621/3327

617/3223

617/3230

617/3900

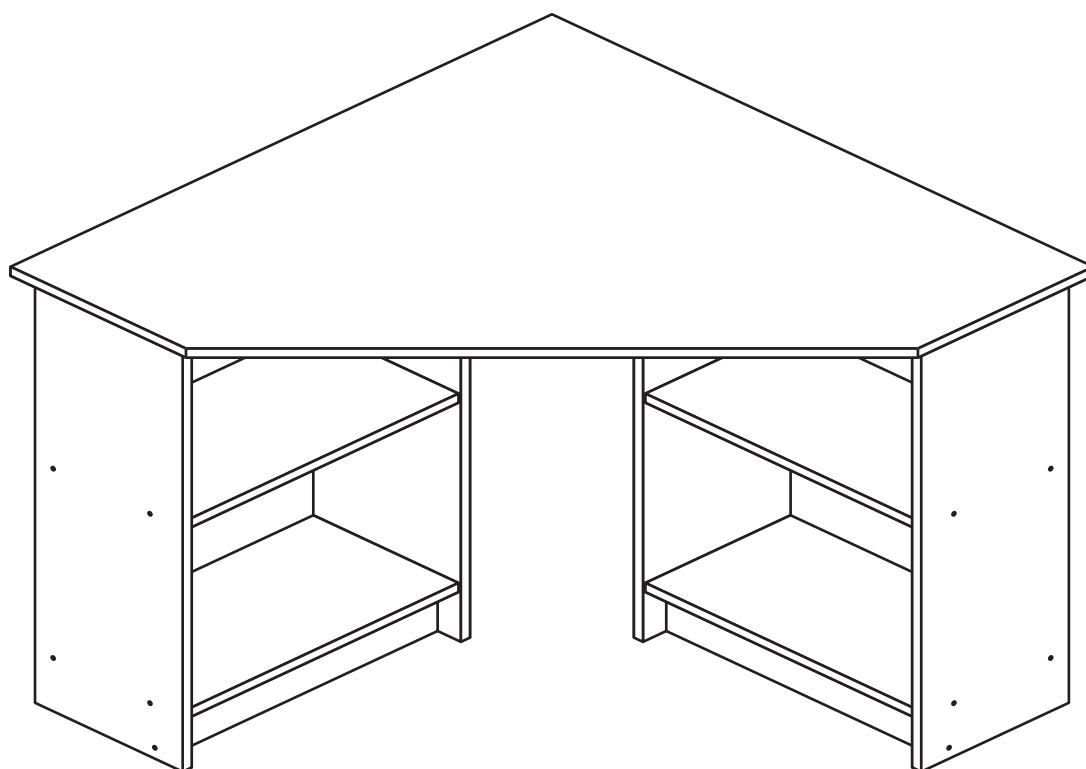

Dimensions

Width - 89.5cm

Depth - 89.5cm

Height - 72cm



**MADE IN
BRITAIN**

Important - Please read these instructions fully before starting assembly

If you need help or have damaged or missing parts, call the **Customer Helpline: 03456 400800**



Safety and Care Advice

Important - Please read these instructions fully before starting assembly

- **Warning:** This unit weighs approximately 19kgs. Please lift with care.

- Check you have all the components and tools listed on pages 2 and 3.

- Remove all fittings from the plastic bags and separate them into their groups.

- Keep children and animals away from the work area, small parts could choke if swallowed.

- Parts of the assembly will be easier with 2 people.

- Make sure you have enough space to layout the parts before starting.

- Do not stand or put weight on the product, this could cause damage.

- Assemble the item as close to its final position (in the same room) as possible.

- Assemble on a soft level surface to avoid damaging the unit or your floor (use opened out unit carton).



- We do not recommend the use of power drill/drivers **for inserting screws**, as this could damage the unit. Only use hand screwdrivers.

- **Safety note:** It is recommended that this unit is secured to a wall using the overbalance protector kit supplied or, an alternative fixing method of your choice.

- Dispose of all packaging carefully and responsibly.

Care and maintenance

- Only clean using a damp cloth and mild detergent, do not use bleach or abrasive cleaners.

- From time to time check that there are no loose screws on this unit.

- This product should not be discarded with household waste. Take to your local authority waste disposal centre.

Note: If required the next page can be cut out and used as reference throughout the assembly. Keep this page with these instructions for future reference.

Components - Panels

If you have damaged or missing components, call the **Customer Helpline: 03456 400800** quoting the reference numbers below

Please check you have all the panels listed below

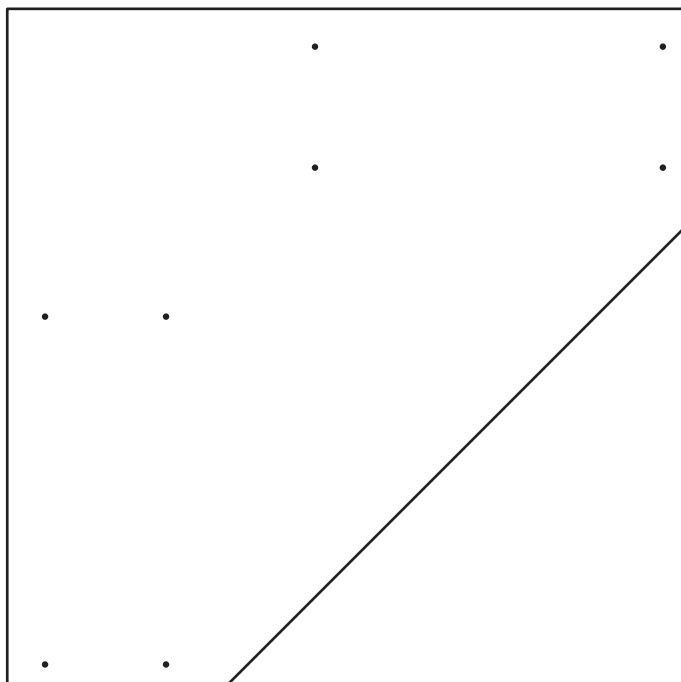

1 Top (D2827A)
(895 x 895mm)

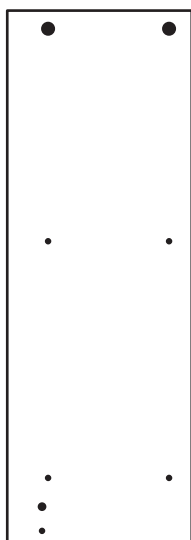

2 Left Side (D2828A)
(706 x 244mm) x 2

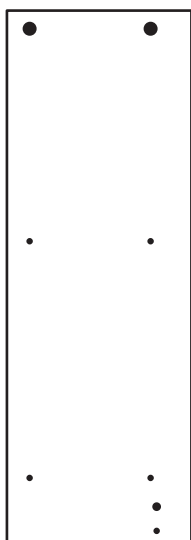

3 Right Side (D2829A)
(706 x 244mm) x 2



4 Plinth (D2830A)
(445 x 80mm) x 2

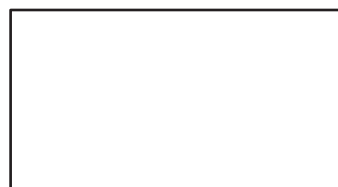

5 Shelf (D2831A)
(445 x 240mm) x 4







Components - Fittings

If you have damaged or missing components, call the **Customer Helpline: 03456 400800** quoting the reference numbers below

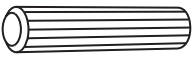
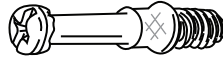
Please check you have all the fittings listed below

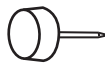
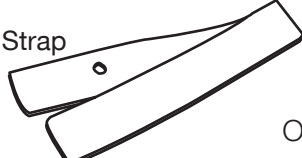
Note: The quantities below are the correct amount to complete the assembly. In some cases more fittings may be supplied than are required.

<p>A </p> <p>Wooden dowel (F22) x 4</p>	<p>B </p> <p>Metal dowel (F901) x 8</p>	<p>C </p> <p>Large locking nut (F900) x 8</p>
<p>D </p> <p>40mm Screw (F910) x 20</p>	<p>E </p> <p>Plastic Nail (F91) x 8</p>	
<p>F   Screw  Washer x 2</p> <p>Overbalance protector kit (F269) x 1</p>		

Tools required



Rule



Cross-head screwdriver



Scissors



Hammer



Eye protection (when using a hammer or drill)



Electric drill (only use when drilling into walls)

Ruler - Use this ruler to help correctly identify the screws

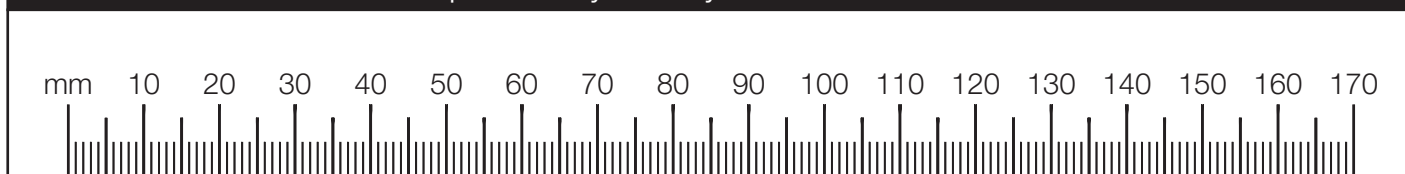

Assembly Instructions

If you have damaged or missing components, call the
Customer Helpline: 03456 400800 quoting the reference
numbers below

Step 1

Prepare the 2 left sides

Insert 2 large locking nuts **C** into each of the left sides **2**.

Note: The arrow on the locking nut **must** point towards the hole in the edge of the panel.

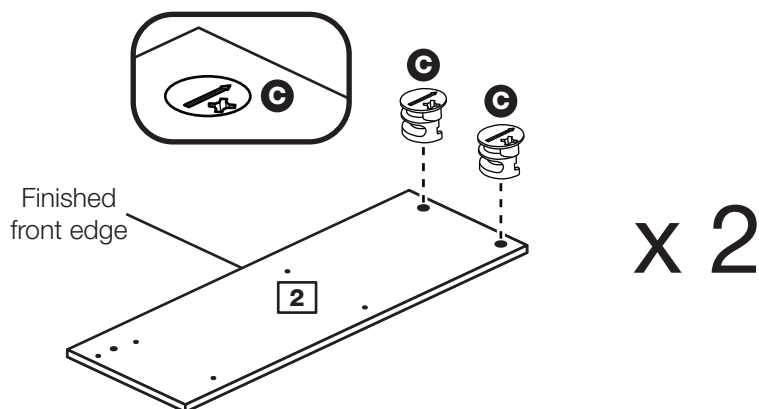

Step 2

Prepare the 2 right sides

Insert 2 large locking nuts **C** into each of the right sides **3**.

Note: The arrow on the locking nut **must** point towards the hole in the edge of the panel.

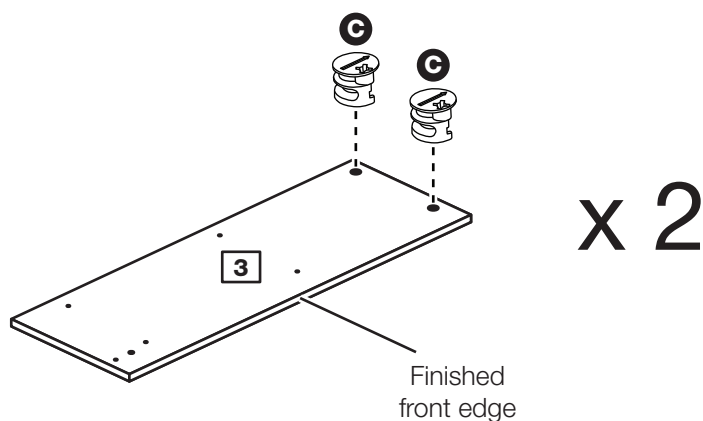

Step 3

Join the left side and shelves

Position 2 shelves **5** against each of the left sides **2** as shown and secure with 4 screws **D**.

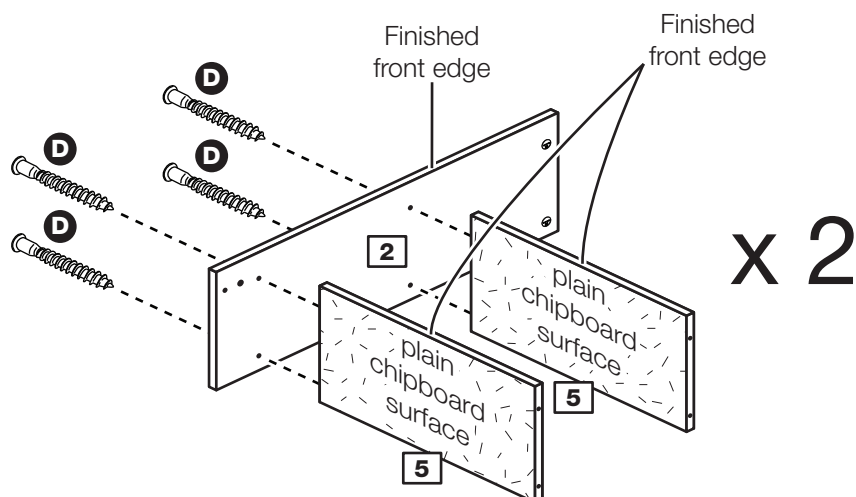

Assembly Instructions

Step 4

Prepare the plinths

Tap 2 wooden dowels **A** into each plinth **4**.

Note: Wooden dowels **must not** stick out from the edge by more than 10mm or they may damage other panels.

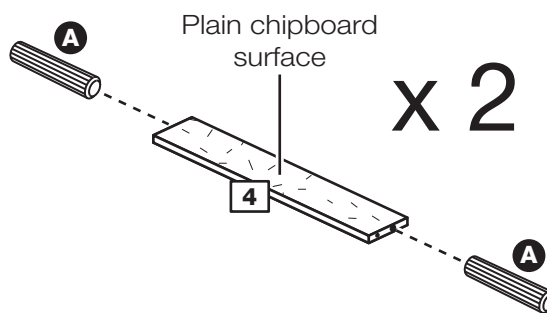

Step 5

Fit the plinths

Push a plinth **4** onto each left side **2** as shown and secure with screw **D**.

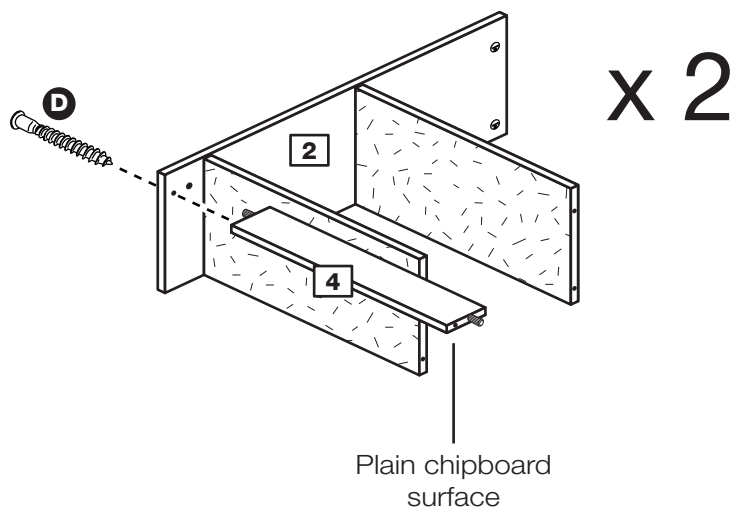

Step 6

Fit the right sides

Push a right side **3** onto each assembly as shown and secure with 5 screws **D**.

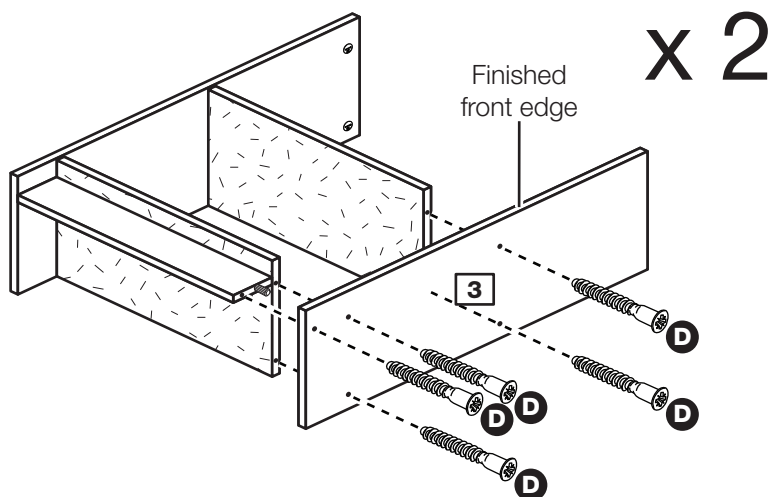

Assembly Instructions

Step 7

Prepare the top

Screw 8 metal dowels **B** into the top **1**.

Note: Tighten the metal dowels up fully against the panel.

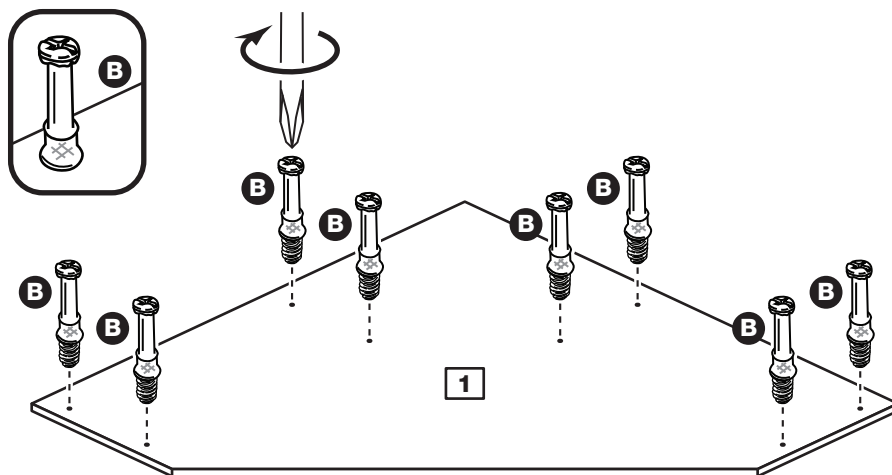

Step 8

Fit the top and fit the plastinails

Push the 2 shelf assemblies down onto the top **1**.

Use a screwdriver to tighten the 8 large locking nuts **C** fitted to the inside of the side panels **2** and **3**.

Note: Turn the large locking nuts **C** as far as they will go - more than 1/2 a turn.

Tap 2 plastic nails **E** into the bottom edge of each of the side panels **2** and **3**.

Carefully turn the desk the correct way up



Warning: The unit is heavy. Lift with care.

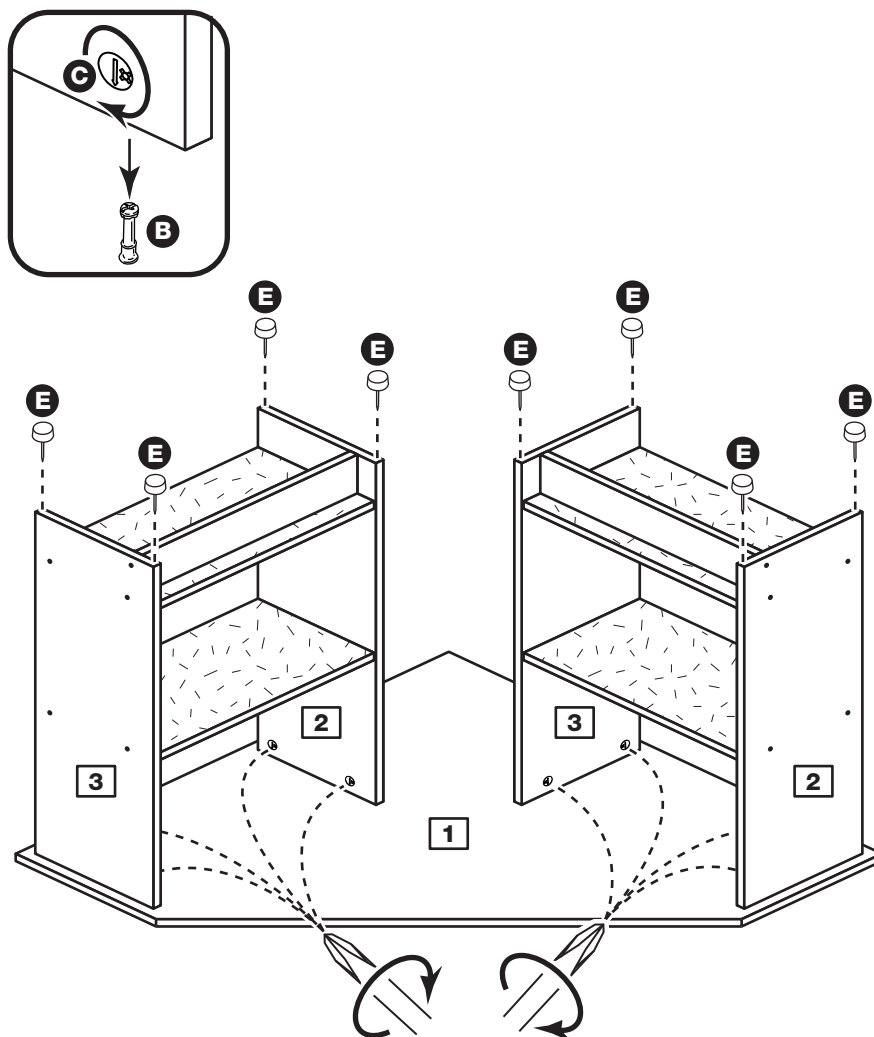

Assembly Instructions

Step 9

Fit the overbalance protector kit

To prevent possible overbalancing we recommend that this unit is secured to a suitable wall by fitting of the overbalance protector kit **F** to the unit, or an alternative fixing method of your choice.

Wall fixings are not supplied as they will need to suit the wall type.

Note: Take care when drilling the wall that you do not drill into any pipes, wires etc. If in doubt, consult an expert.

Assembly is complete

Example

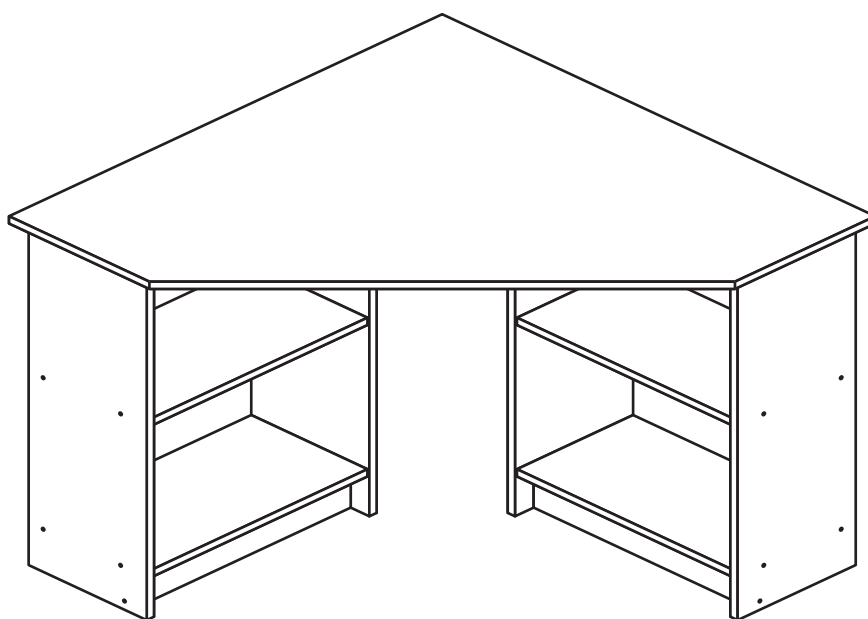
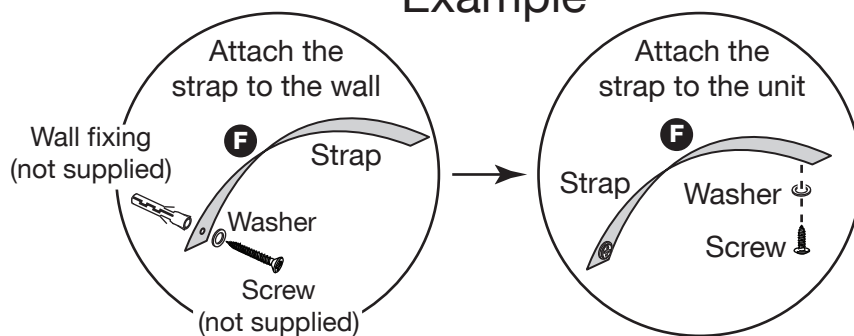

If you need help or have damaged or missing parts, call the Customer Helpline: 03456 400800 and quote the reference numbers on the component pages.

Argos Ltd, 489-499 Avebury Boulevard, Central Milton Keynes, MK9 2NW