

Easy Fold Treadmill

Assembly & User Instructions- Please Keep for future reference

616/6773

ROGERBLACK
FITNESS 

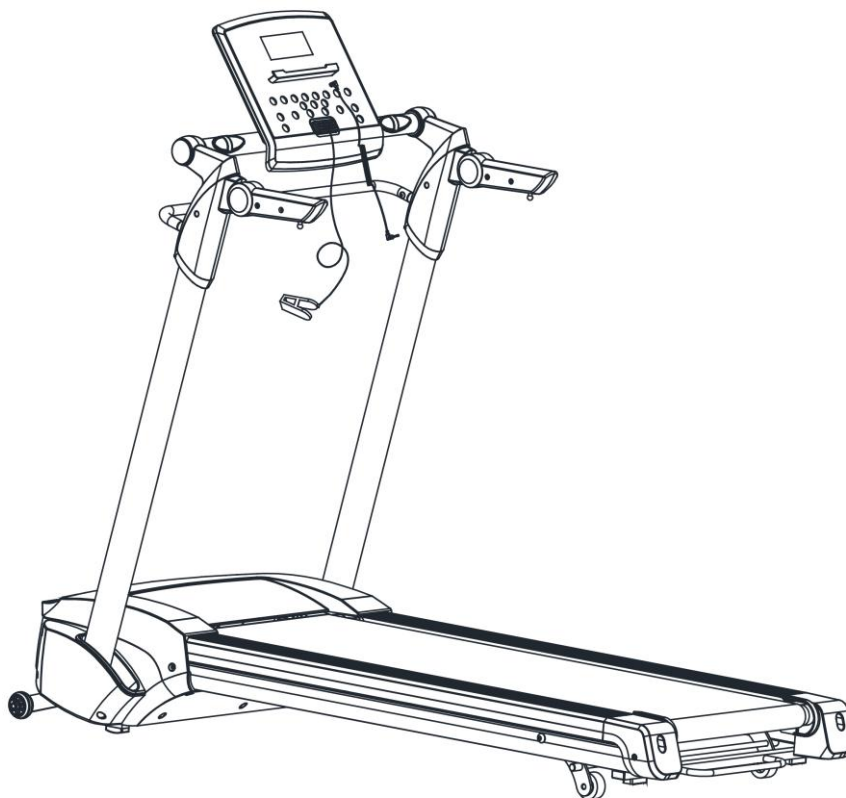

Important – Please read these instructions fully before assembly or use

These instructions contain important information which will help you get the best from your equipment and ensure safe and correct assembly, use and maintenance.

If you need help or have damaged or missing parts, call the **Customer Helpline: 0345 600 1714**

Issue 1 -25/02/16

Contents

Safety Information	1-
2	Error! Bookmark not defined.-3
Components - Parts	
3	1
Assembly Instructions	4-
7	1-10
Workout Area	
8	11
Exercise Information	9-
21	12-26
Before starting	
9	12
Muscle Chart	
10	13
Warming up and Cooling down	11-
12	14-15
Getting started	13-
14	16-17
Console operation	15-
20	18-25
Folding Mechanism and Locking System	21
Care and Maintenance	22-26

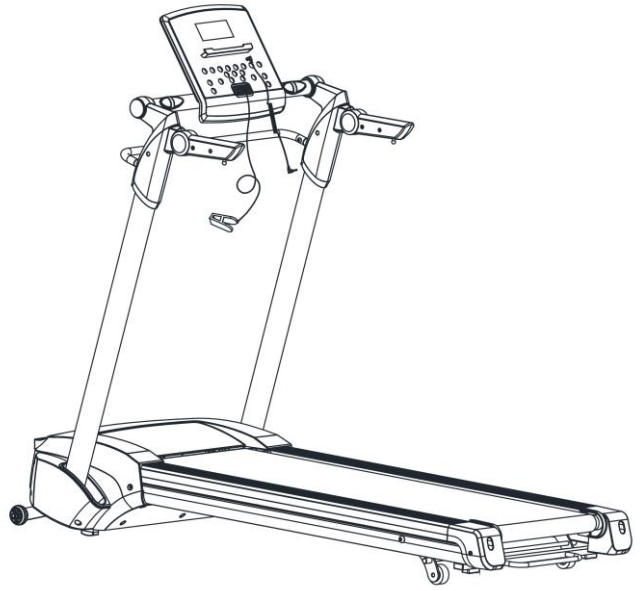

Safety information

Important – Please read fully before assembly or use

This exercise equipment is built for optimum safety. However, certain precautions apply whenever you operate a piece of exercise equipment. Be sure to read the entire manual before you assemble, operate or use this equipment.

Assembly

- The product must be installed on a stable and level surface. Do not place the treadmill on any surface that blocks air openings. To protect the floor or carpet from damage, place a mat under the treadmill.
- Assemble the item as close to its final position (in the same room) as possible.
- Make sure you have enough space to layout the parts before starting.
- Keep children and animals away from the exercise area, small parts could pose a choking hazard if swallowed.
- Dispose of all packaging carefully and responsibly.
- Check you have all the components and tools listed in the parts list, bearing in mind that, for ease of assembly, some components are pre-assembled.
- The assembly of this equipment is best carried out by 2 people.
- Attention! Take care when unboxing and assembling your treadmill.
- On unboxing, ensure the treadmill is flat on the floor (with the wheels in contact with the ground), before cutting the retaining cable ties on both sides of the product.
- Do not under any circumstance turn the machine on its side. Failure to follow these instructions could result in serious injury.

Use

- It is the responsibility of the owner to ensure that all users of this product are properly informed as to how to use this product safely.
- This product is intended for domestic use only.
Do not use in any commercial, rental, or institutional setting.
- Use the equipment only for intended use, as described in this manual. Do not use attachments not recommended by the manufacturer.
- Keep this equipment indoors, away from moisture and dust. Do not put the equipment in a garage, outbuilding, covered patio, or near water.
- Your product is intended for use in clean dry conditions. You should avoid storage in excessively cold or damp places as this may lead to corrosion and other related problems that are outside our control.
- Keep unsupervised children away from the equipment.
- Disabled persons should not use the equipment without a qualified person or doctor in attendance.
This product is not suitable for therapeutic purposes.
- Always wear appropriate workout clothing when exercising. **Do not** wear loose or baggy clothing, as it may get caught in the equipment. Wear trainers to protect your feet while exercising.
- **Do not** place any sharp objects around the equipment.
- Keep hands away from all moving parts.

- If any of the adjustment devices are left projecting, they could interfere with the user's movement.
- Before using the equipment to exercise, always perform stretching exercises to properly warm up.
- Only one person at a time should use the equipment.
- A spotter is recommended during exercise.
- If the user experiences dizziness, nausea, chest pain, or other abnormal symptoms, stop the workout



Safety information

excessive training.

- This product is suitable for a maximum user weight of: **110 kg**.

- Noise emission under load is higher than without load.
- When choosing a location for the equipment make sure that the location and position permit access to a plug.
- Do not operate this equipment where aerosol products are used or where oxygen is being administered.
- When connecting the power cord, plug the power cord into a grounded circuit. When replacing the fuse, an approved BS 1362 type should be fitted to the fuse carrier, A13 amp fuse should be used. No other appliance should be on the same circuit.
- Keep the power cord away from any heated surface.
- Do not operate the equipment if the power cord or plug is damaged, or if the equipment is not working properly.

- This product conforms to: BS EN ISO 20957-1 and BS EN 957-6 Class (H) - Home Use - Class (C).

- A folded treadmill should not be operated.
- Ensure the running surface comes to a complete stop before folding.
- The A-weighted emission sound pressure level is from 50 to 60 dBa.

- Never start the treadmill when you are standing on the running belt. Stand on the side rail, hold the handrails, start on a low speed and then step on the unit. When comfortable increase the speed to one that you are comfortable with.
- The treadmill is capable of high speeds. Adjust the speed in small increments to avoid sudden changes in speed.
- Never leave the treadmill unattended while it is running. Always remove the safety key when the treadmill is not in use.
- Always examine your treadmill before use to ensure all parts are in working order.
- Never insert any object or body parts into any opening.



Warning: Before beginning any exercise program, consult your Doctor. This is especially important for persons over the age of 35 or persons with pre-existing health problems. You **MUST** read all instructions before using any fitness equipment. Argos and its associates assumes no responsibility for personal injury or property damage sustained by or through the use of this product. Over exercising may result in serious injury or death. If you feel faint stop exercising immediately. Warning! Heart rate monitoring systems may be inaccurate. For the most accurate heart rate measure, please hold both hand pulse sensors continuously during any programme.

Components - Parts

If you have damaged or missing parts, please call the **Customer Helpline: 0345 600 1714.**

Please check you have all parts listed below

Note: Some of the smaller components may be pre-fitted to larger components. Please check carefully before contacting Argos regarding any missing components.

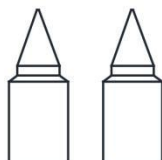

Lubrication Oil x 2



Main Frame x 1

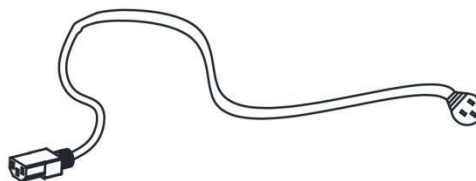

Power Cord x 1



MP3 Connection x 1



Safety Key x 1

3

Assembly Instructions

Total mass of the product is 52 kg. Total size of the equipment is (width) 168.5 cm × (depth) 76 cm × (height) 29 cm.

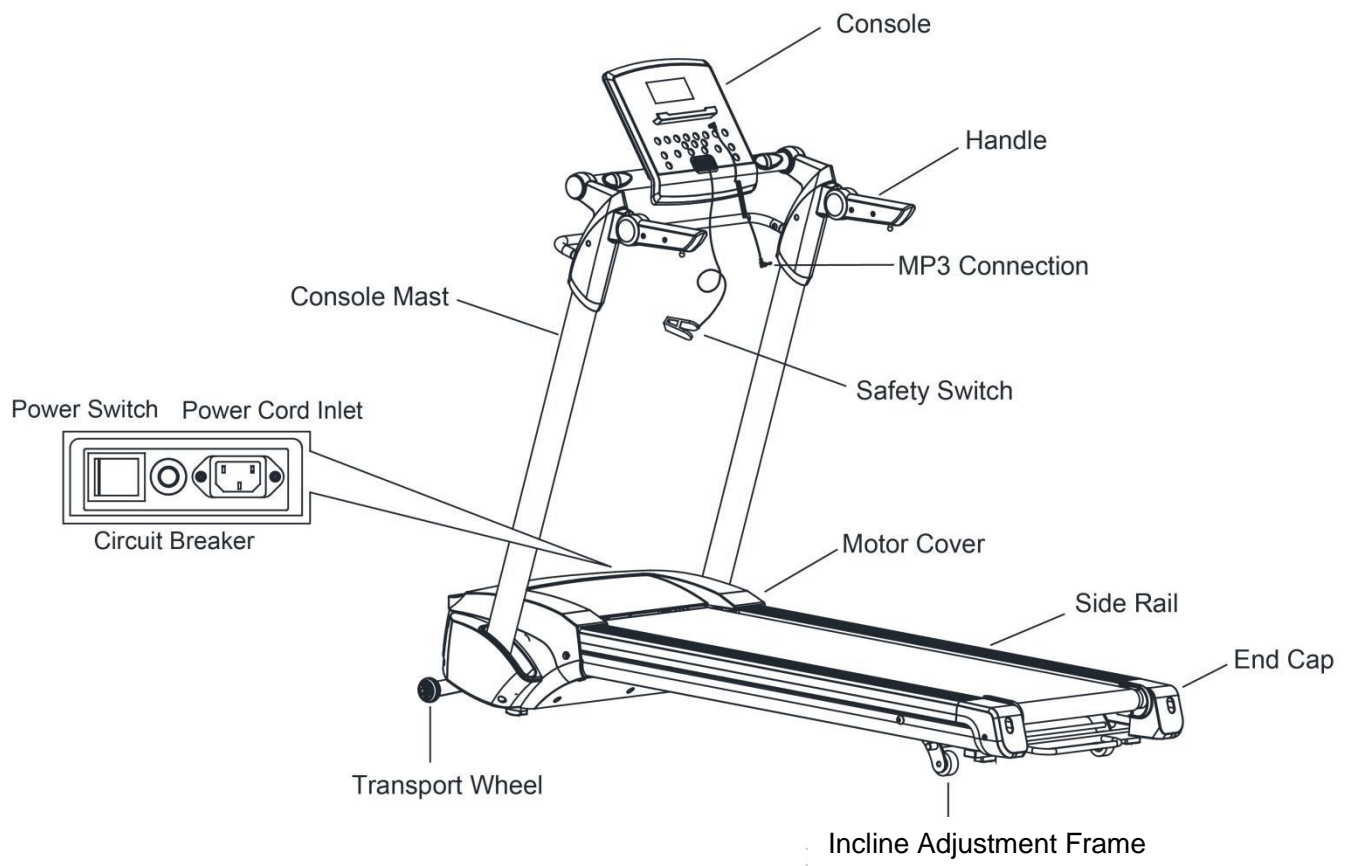

Assembly Instructions

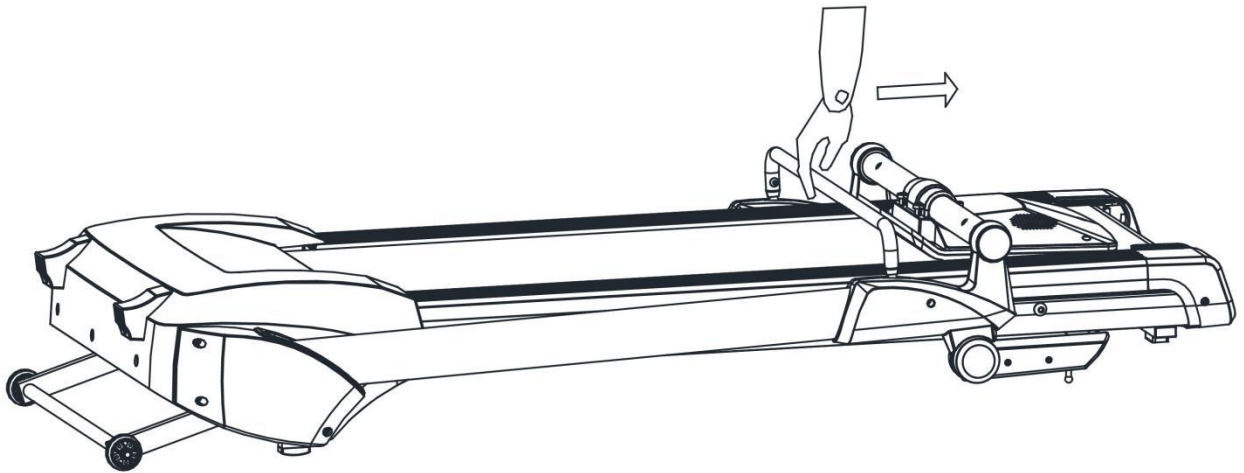

Step 1

Unbox the outer carton and take out the main frame.

Grasp the console rod with one hand, and pull the lifting bar with another hand to the direction of the arrow as shown in the diagram.

5 Assembly Instructions

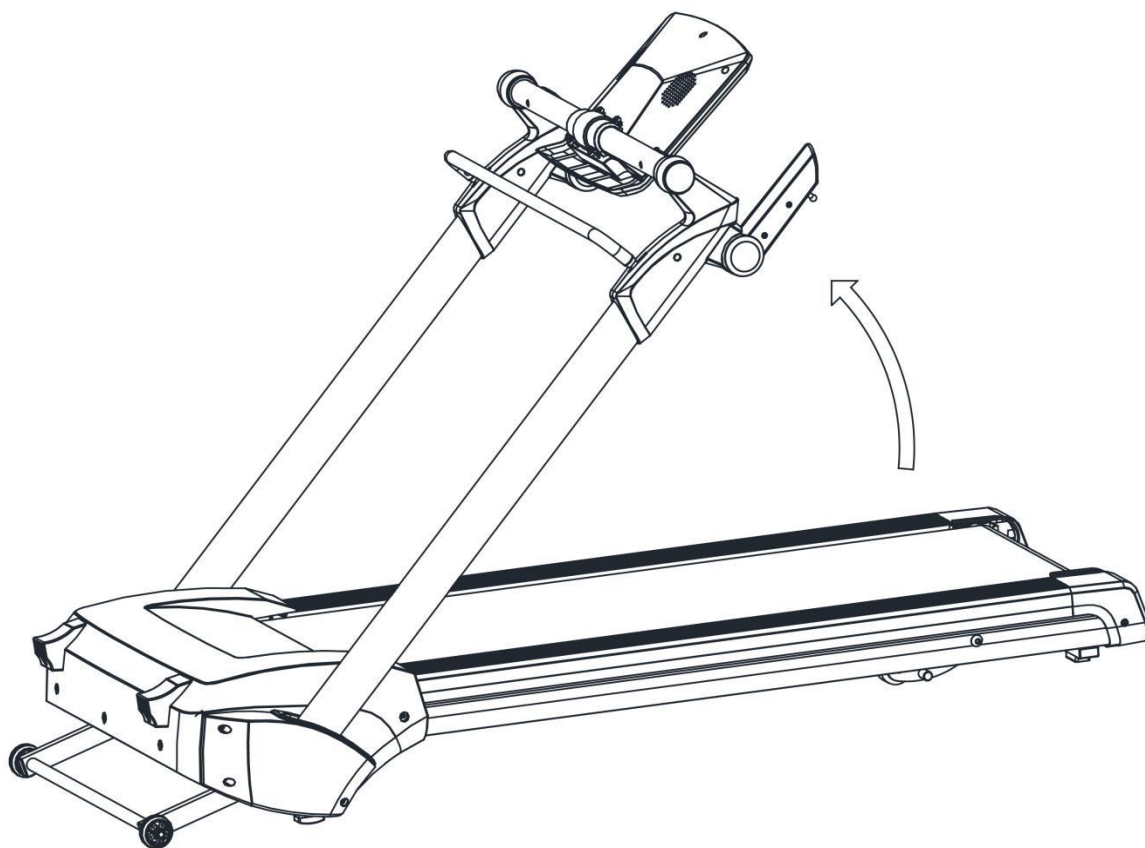

Step 2

Grasp the lifting bar and pull to the direction as shown in the diagram.

Assembly Instructions

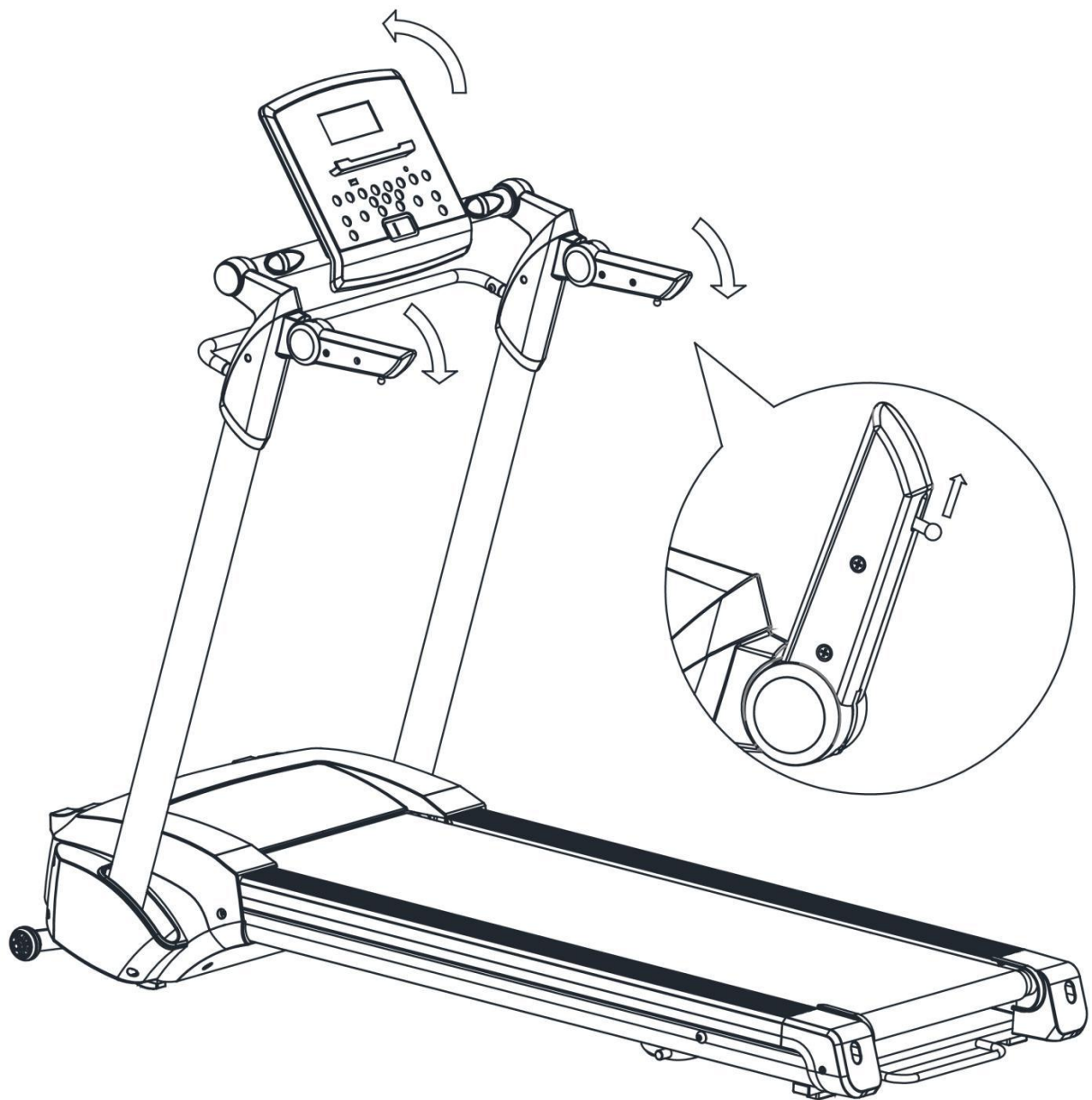

Step 3

When the console masts are folded in place, please loosen the lifting bar. Then fold the console housing and handrail in place as shown in the diagram.

Notes: the handle can be folded only after pull the ball pin on the end of the handle

⁷Workout Area

The free area must be at least 0.6m greater than the training area. This is a space where you can safely dismount, without obstruction, in case of an emergency. Where two pieces of equipment are positioned adjacent to each other the free area may be shared. The free area behind the treadmill should be 2m in length and double the width of the product.

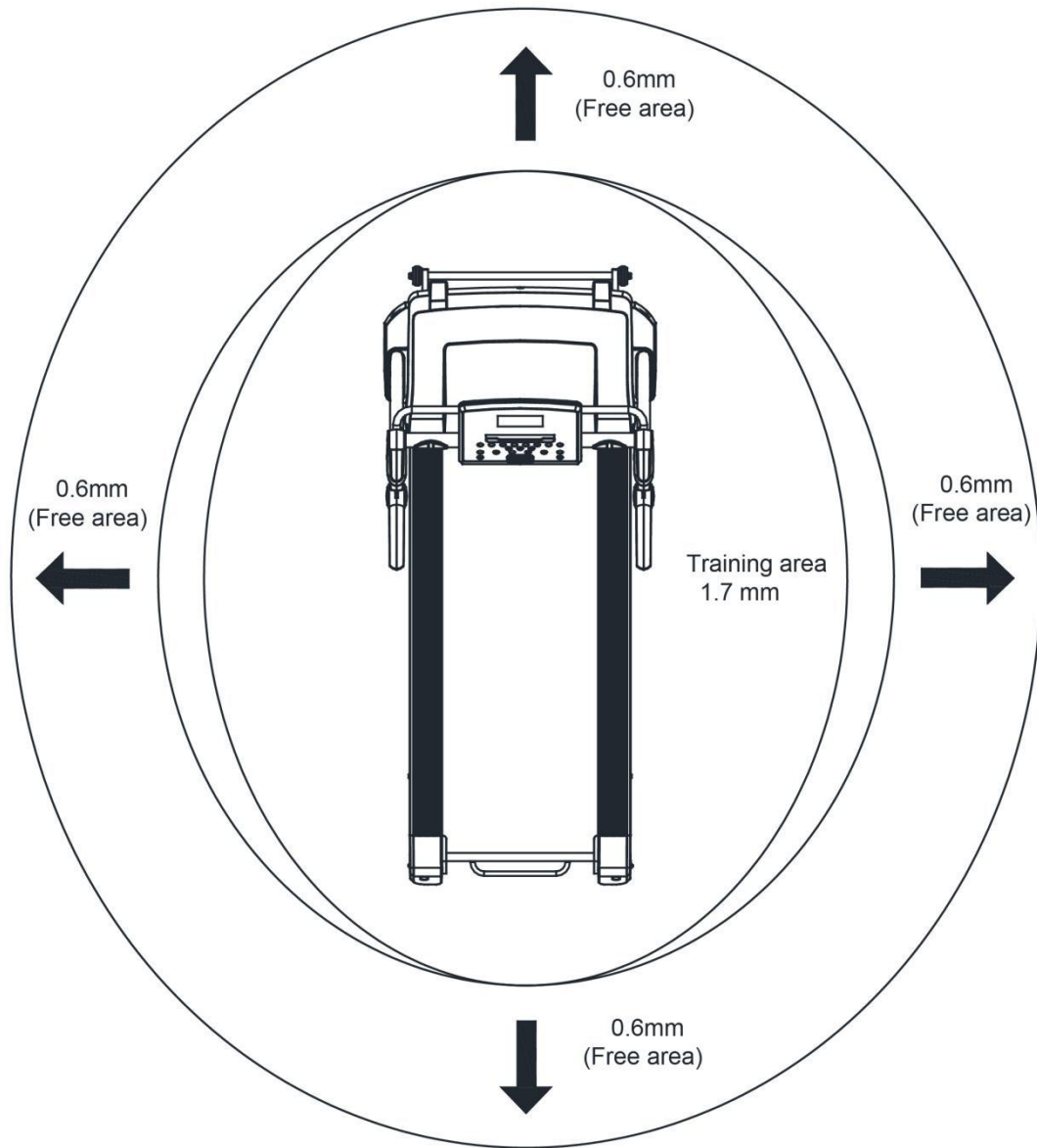

Only one person should be within the training area when the equipment is in use.

Before starting

Tailor your exercise program according to your physical condition. If you have been inactive for several years, or are overweight, you must start slowly and increase your time on the equipment; a few minutes per workout increase is advisable.

Initially, you may be able to exercise only for a few minutes in your target zone, however, your aerobic fitness will improve over the next six to eight weeks. Don't be discouraged if it takes longer. It's important to work at your own pace.

Please remember these essentials:

- Have your doctor review your training and diet programs to advise you of a workout routine you should adopt.
- Begin your training program slowly with realistic goals.
- Monitor your pulse frequently. Establish your target heart rate based on your age and condition.
- Set up your equipment on a flat even surface with adequate training area, as prescribed in this manual.

Exercise intensity

To maximize the benefits of exercising, it is important to exercise at an appropriate intensity. The intensity level can be found by using your heart rate as a guide. For effective aerobic exercise, your heart rate should be maintained at a level between 65% and 85% of your maximum heart rate as you exercise. This is known as your target zone. You can find your target zone in the table below.

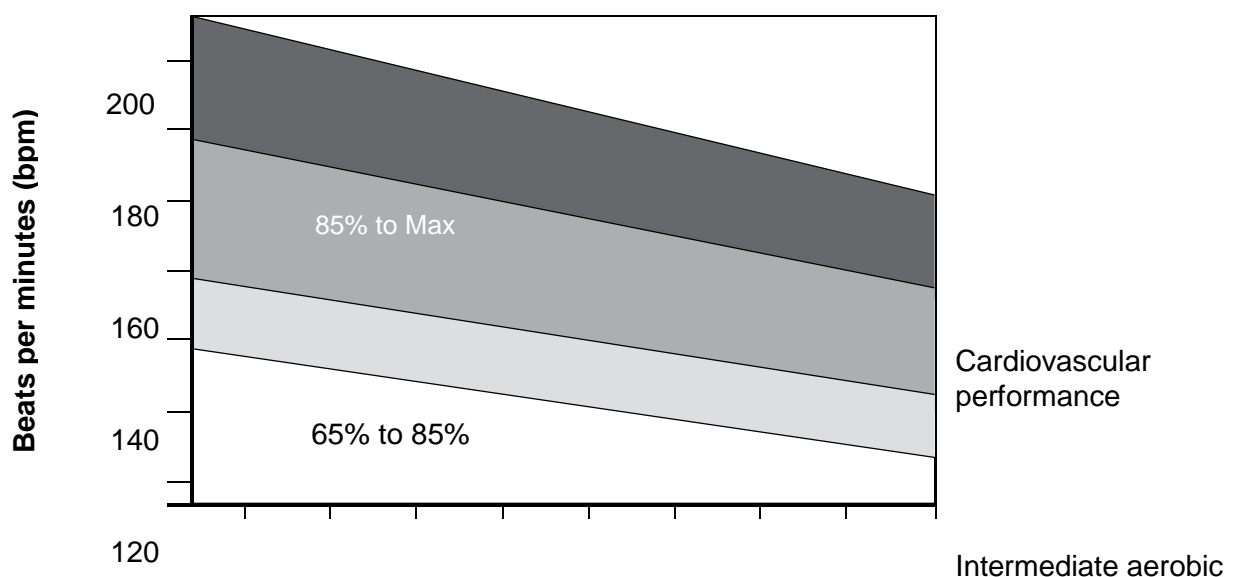

100

Effective fat burning

80

25 30 35 40 45 50 55 60 70

Age

During the first few months of your exercise program, keep your heart rate near the low end of your target zone as you exercise. After a few months, your heart rate can be increased gradually until it is near the middle of your target zone as you exercise.

To measure your heart rate, stop exercising but continue moving your legs or walking around and place two fingers on your wrist. Take a six-second heartbeat count and multiply the results by 10 to find your heart rate. For example, if your six-second heartbeat count is 14, your heart rate is 140 beats per minute.

(A six-second count is used because your heart rate will drop rapidly when you stop exercising.) Adjust the intensity of your exercise until your heart rate is at the required level.

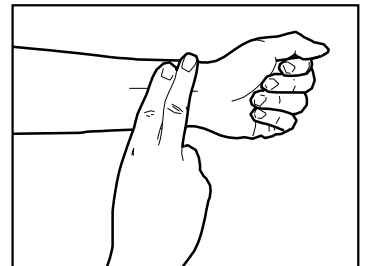

9

Exercise Information

Muscle Chart

Aerobic Exercise

Aerobic exercise improves the fitness of your lungs and heart - your body's most important muscle. Aerobic exercise is promoted by any activity that uses your large muscles (arms, legs, or buttock, for example).

Weight Training

Along with aerobic exercising which helps get rid of and keep off the excess fat that our bodies can store, weight training is an essential part of an exercise routine. Weight training helps tone, build and strengthen muscle. If you are working above your target zone, you may want to do a lower number of reps.

Targeted Muscle Groups

The exercise routine that is performed on the treadmill will develop combined the lower body muscle groups. These muscle groups are highlighted on the muscle chart below.

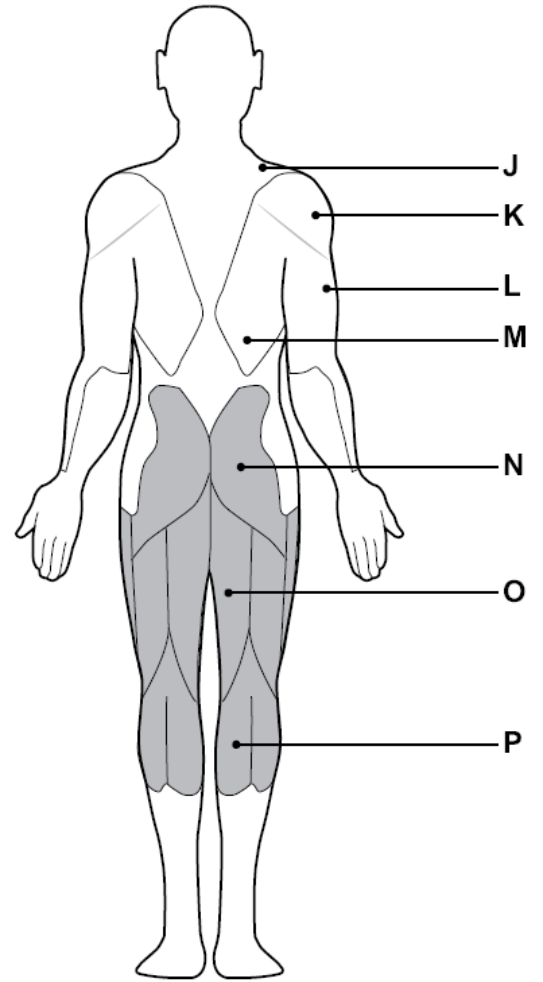
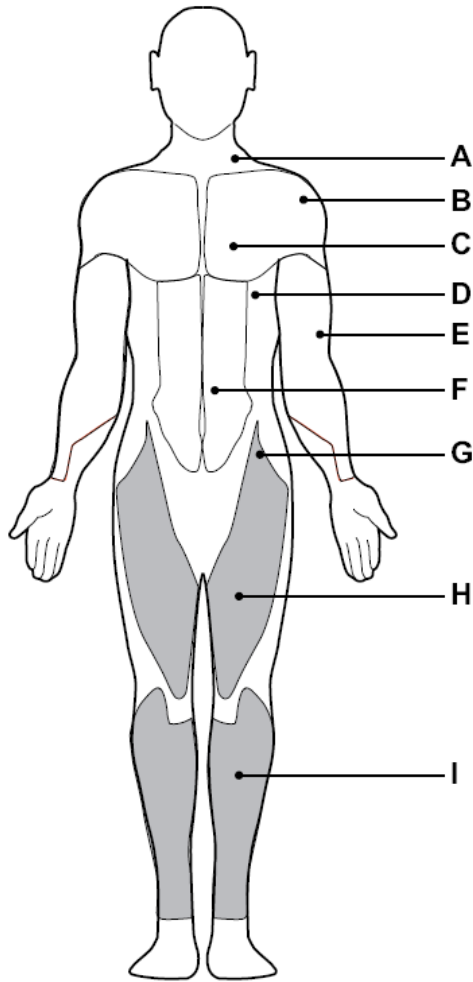

- A: Trapezius
- B: Anterior Deltoid
- C: Pectoralis Major
- D: Serratus Anterior

- E: Biceps
- F: Abdominal
- G: Sartorius
- H: Quadriceps

- I: Tibialis Anterior
- J: Trapezius
- K: Posterior Deltoid
- L: Triceps

- M: Latissimus Dorsi
- N: Gluteals
- O: Hamstrings
- P: Gastrocnemius

Exercise Information

Each workout should include the following three parts:

1. A warm-up, consisting of 5 to 10 minutes of stretching and light exercise. A proper warm-up increases your body temperature, heart rate, and circulation in preparation for exercise.
2. Training zone exercise, consisting of 20 to 30 minutes of exercising with your heart rate in your training zone. (**Note:** During the first few weeks of your exercise program, do not keep your heart rate in your training zone for longer than 20 minutes.)
3. A cool-down, with 5 to 10 minutes of stretching. This will increase the flexibility of your muscles and will help to reduce post-exercise muscle soreness.

Exercise Frequency

To maintain or improve your fitness, plan three workouts each week, with at least one day of rest between workouts. After a few months of regular exercise, you may complete up to five workouts each week, if desired. Remember, the key to success is make exercise a regular and enjoyable part of your

Toe touch stretch

Stand with your knees bent slightly and slowly bend forward from your hips. Allow your back and shoulders to relax as you reach down towards your toes as far as possible.

Hold for 15 counts, then relax

Repeat 3 times.

Stretches: Hamstrings, back of knees and back.

Hamstring stretch

Sit with one leg extended. Bring the sole of the opposite foot toward you and rest it against the inner thigh of your



extended leg. Reach towards your toes as far as possible.

Hold for 15 counts, and then relax.

Repeat 3 times for each leg.

Stretches: Hamstrings, lower back and groin.

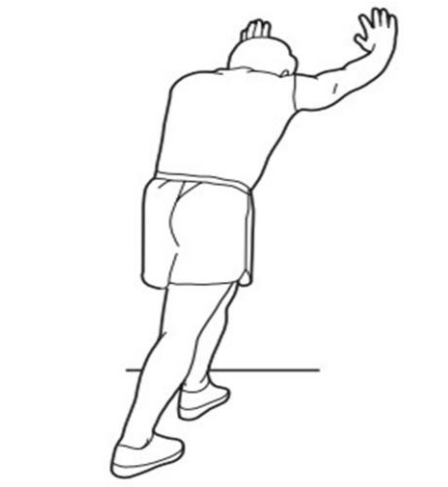

11

Exercise Information

Calf/Achilles stretch

With one leg in front of the other, reach forward and place your hands against a wall. Keep your back leg straight and your back foot flat on the floor. Bend your front leg, lean forward and move your hips toward the wall.

Hold for 15 counts, then relax.

Repeat 3 times for each leg. To cause further stretching of the Achilles tendons, bend your back leg as well.

Stretches: Calves, Achilles tendons and ankles.

With one hand against the wall for balance, reach back and grasp one foot with your other hand. Keeping your bent knee

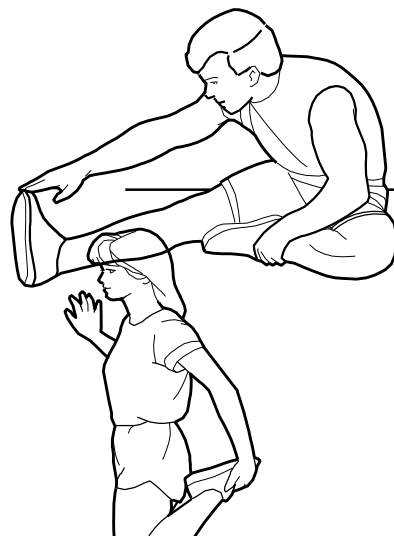

pointing directly down towards the floor, gently pull your heel towards your buttock until you feel a gentle stretch in the target area.

Hold for 15 counts, and then relax.

Repeat 3 times for each leg.

Stretches: Quadriceps and Hip muscles.

Inner thigh stretch

Sit with the soles of your feet together and your knees outwards. Pull your feet towards your groin area as far as possible, and push your knee down towards the ground.

Hold for 15 counts, and then relax.

Repeat 3 times.



Stretches: Quadriceps and Hip muscles.

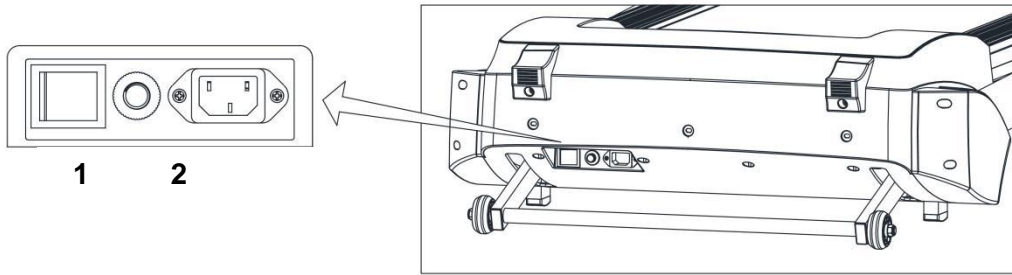

Plug your fitness equipment into the mains power and turn on the switch (1).

You will hear a beep and the computer screen will light up.

OVER-CURRENT PROTECTOR:

There is an over-current protector (2) located on the right side of the switch (1) (see above picture); in case of short circuit or over-current, the Button of the over current protector will pop up and the treadmill

Exercise Information

Getting Started

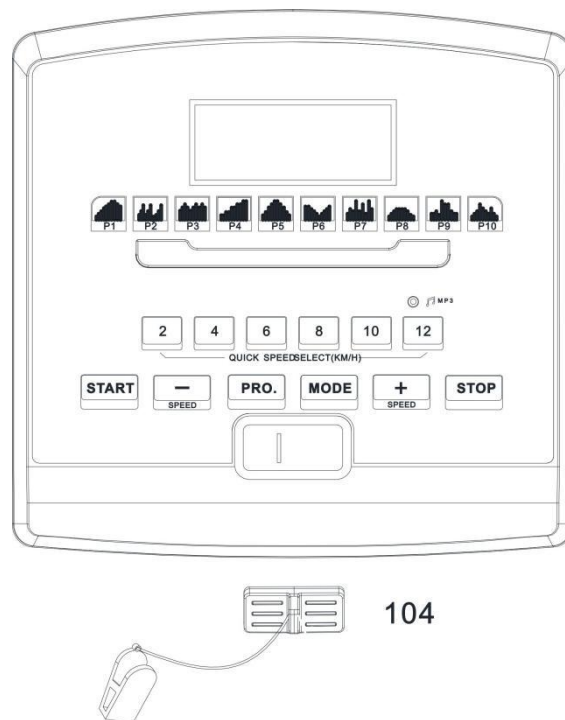



SAFETY KEY:

The treadmill will only work if the safety key (**104**) is properly locked in the provided notch of the console. Insert the safety key (**104**) and attach the clip to your chest or the waist belt of your clothes. Then move backward to test the safety key. The safety key should be able to be pulled out from the console with the clip still on your clothes.

If you need to turn the motor off immediately, just pull the safety key (**104**) out of the console. For emergency dismount hold the left or right handlebar then jump onto the side rail or the floor.

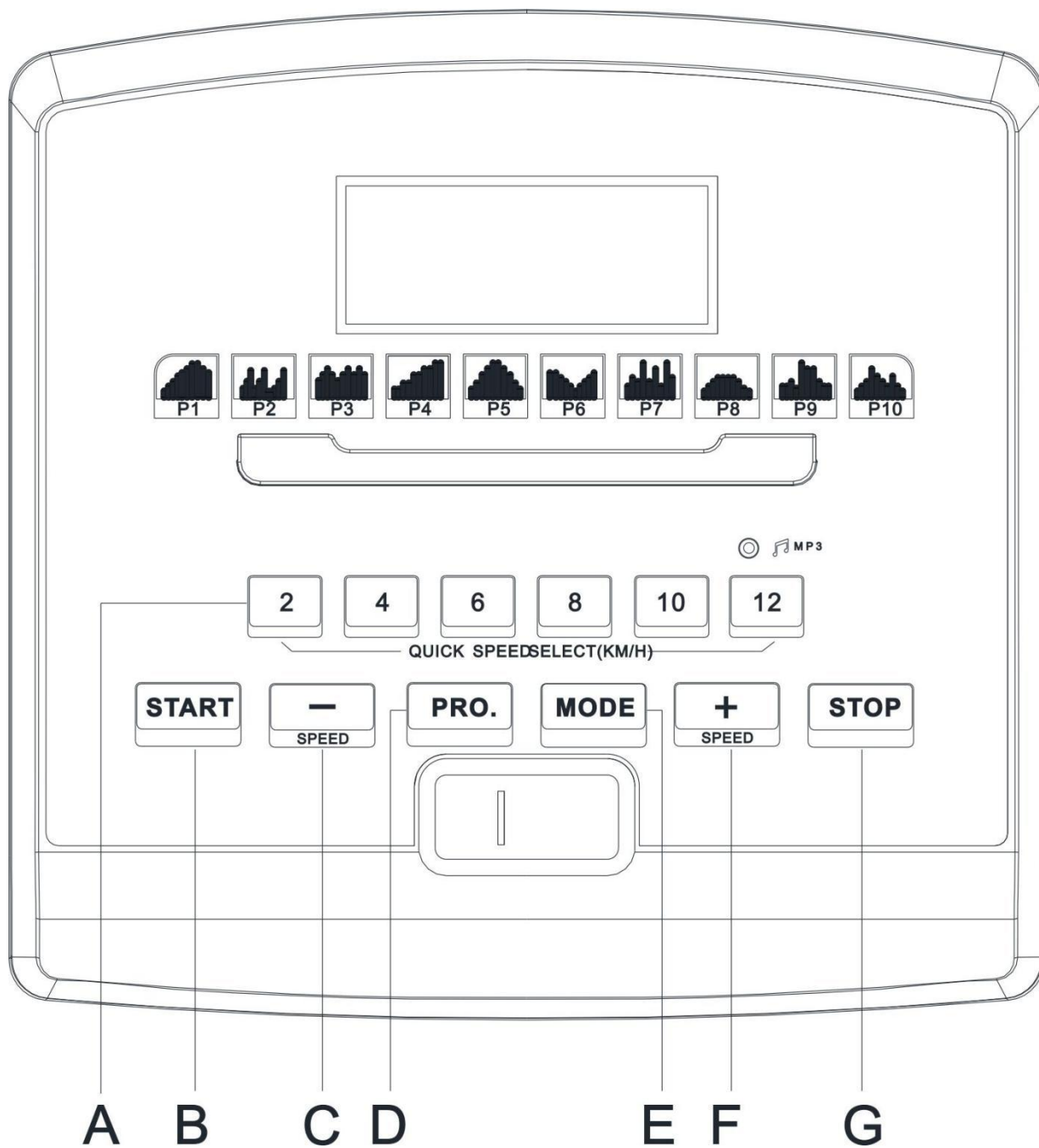

- A Quick Speed Select
- B Start
- C Speed-
- D PRO.
- E MODE
- F Speed+
- G Stop

Exercise Information

Console Operation

TECHNICAL SPECIFICATION

Time-----00:00--99:59 Min

Speed-----0.0--13.0 km/h

Distance-----0.0--99.9 km

Calories-----0--999 Kcal

START

On standby status, press it to start motor; on data storing status, press it to start and all data will be counted forward.

STOP

Press during workout, and the treadmill will stop and simultaneously store the data; while on data storing status, press it may clear all the stored data.

QUICK SPEED SELECT

Press to select your desired running speed of 2, 4, 6, 8, 10 or 12km/h.

SPEED UP/DOWN

1. Press to increase/decrease exercise speed by 0.1km/h.
2. Press to select training time within a workout programme.
3. Press to select the desired training target (Time, Distance, Calories) within the target workouts.

MODE

Press to select training target workout mode (Time-Distance-Calories count down).

PRO.

Press to select workout program (P01-P02-...-P10).

Exercise Information

Console Operation

IMPORTANT

- The console will turn off automatically approximately ten minutes after the belt stopped, and press any button on the console

will wake it up.

SAFETY KEY

- The safety key must be placed into the magnetic recess on the console in order to operate the treadmill. Always place the safety key in this position and attach the clip to your clothing waist band before beginning your workout.
- If you should need to stop the motor immediately, simply pull the safety key away from the console.

GENERAL OPERATION

1. Turn on the power switch at the front of your treadmill. This switch is located next to the mains power cord inlet.
2. Place the safety key into the magnetic recess on the middle front of the computer console.

The console will beep and all console window displays will function with a start display value of 0.

Note: If the Safety Key is not placed correctly or is faulty, the “Speed” window will display "E00", which indicates that the treadmill will not operate.

If the Safety Key is removed during exercise, the console will beep and “Speed” window will display “E00” and the treadmill will stop.

To stop the treadmill in an emergency, simply pull the safety key or press the red STOP button in the centre of the console. It is important that you connect the clothing clip to your shirt or other suitable clothing during exercise to ensure that this safety system can operate easily.

Note: The readings displayed by the computer should not be used for therapeutic purposes as they can vary due to the sensitivity of the equipment. Over exercising may result in serious injury or death. If you feel faint stop exercising immediately.

Exercise Information

Console Operation

● START YOUR TREADMILL

Turn on the treadmill, and press the “Start” button on the console.

Press “Speed +” or “Speed -” to adjust the speed. Pressing the key once, will change the speed by 0.1Km/H.

Also the user can press the “Quick Speed Select” button to select desired running speed.

● STOP YOUR TREADMILL

Press the “Speed -” button on the console to reduce the speed, then press the “Stop” key on the Console, and the treadmill will stop; turn off the switch if you intend to finish your workout.

If you remove the safety key the treadmill will stop and the console will display E00 until the safety key is replaced.

● TRAINING TIME CONTROL WORKOUT

MODE

Turn on the treadmill, press the “MODE” button once, the “Time” window flashes and displays “15:00”. Press “Speed +” / “Speed -” button to select your desired training time, (the range is 5:00—99:00 minutes).

Press “Start” to begin your workout, the time data will reduce gradually during your training and the treadmill will stop automatically when the “Time” window displays “0:00”.

● TRAINING DISTANCE CONTROL WORKOUT MODEL

Turn on the treadmill, press the “MODE” key twice to enter distance count down mode, the initial distance is: 1.00KM “.

Press “Speed +” / “Speed -” button to select your desired training distance (the range is 0.5—99.9 km).

Press “Start” to begin your workout, the distance data will reduce gradually during your training and the treadmill will stop automatically when the the window displays “0.00”.

- **BURNING CALORIE CONTROL WORKOUT MODEL**

Turn on the treadmill, press the “MODE” button three times to enter Calorie count down mode, the initial calorie is “50.0” Kcal.

Press “Speed +” / “Speed -” button to select the target calories for your workout (the range is 10.0--999 calories).

Press “Start” to begin your workout, the calories data will reduce gradually during your training, and the treadmill will stop automatically when the window displays “0.0”.

- **SPEED ADJUSTMENT**

In any target control workout, press “Speed +” / “Speed -” button to choose your desired running speed.

● **Program Workout Model (P01—P10)**

In this mode, the user has a choice of Program P01 – Program P10.

1. Press the “Pro.” button once, the “Speed” window will display “P01” and the “Time” window will display “10:00”, which is the preset time of the treadmill for each program; press the “Pro. ” button to select your desired training program “P01-P10”.
2. The preset workout time of the treadmill for each program is 10:00Mins; when you finish selecting workout program, press “Speed +” / “Speed -” button to select your desired workout time (the range is: 5:00---99:00

minutes).

3. Press “Start” and the treadmill will count down from three before commencing the workout. The start speed depends on the program you have chosen.
4. For all preset values, please refer to following table and diagrams.

Any of the training program levels has 10 segments, and each segment time is 1/10 of the total time; during any training segments, press the “Speed +” / “Speed -” button to adjust your speed.

TIME PROG		Set Time/10 =Running time for each segment									
		1	2	3	4	5	6	7	8	9	10
P01	SPEED	1.5	3.0	4.5	6.0	7.5	9.0	10.5	10.5	9.0	7.5
P02	SPEED	3.0	4.5	7.5	3.0	4.5	7.0	3.0	4.5	7.0	3.0
P03	SPEED	4.5	6.0	7.5	6.0	4.5	6.0	7.5	6.0	4.5	6.0
P04	SPEED	3.0	3.0	4.5	4.5	6.0	6.0	7.5	7.5	9.0	9.0
P05	SPEED	3.0	4.5	6.0	7.5	9.0	9.0	7.5	6.0	4.5	3.0
P06	SPEED	7.5	7.5	6.0	4.5	3.0	1.5	3.0	4.5	6.0	7.5
P07	SPEED	3.0	6.0	4.5	9.0	4.5	7.5	3.0	9.0	6.0	4.5
P08	SPEED	1.5	3.0	4.5	6.0	6.0	6.0	6.0	4.5	3.0	1.5
P09	SPEED	3.0	3.0	4.5	7.5	7.5	7.5	7.5	4.5	3.0	3.0
P10	SPEED	1.5	3.0	4.5	7.5	6.0	4.5	3.0	6.0	3.0	1.5

Exercise Information

Console Operation

BODY FAT ANALYSIS

- On standby status, press PROG. Button and select FAT to enter body constitution index detection function, and SPEED window displays set parameters, TIME window displays: F-1—Sex, F-2—Age, F-3—Height, F-4—Weight, F-5—Body constitution test; press MODE button to enter next setting, press SPEED+/- button to set parameters (see below table) for F-1—F-4. Press the “FAT” key again, the “Speed” window displays: “25” – Which is the treadmill pre-set user’s age, the “Time” window is displaying “F - 2” .Press “Speed +” or “Speed -” or “Incline +” / “Incline -” button to select your correct age. (Range is: 10 – 99 years).
- When entering F-5 interface, grasp the handle pulse sensor for 5 minutes, it will display your body constitution value, from it may view whether your weight and height is matched. The body constitution index is used to measure the relations between weight and height, not for body proportion, fat test is appropriate for any male and female, together with other health index providing a basis to adjust weight. An ideal body fat is between 20 - 25, lower than 19 means under weight, if between 25 - 29, it means overweight, if exceeding 30 means obesity. (The data is only for reference, not for therapeutic purpose.)

Body Fat Scale Parameter Table

FAT	ITEM	SET OR ANALYSIS DATA	
F-1	Gender	01-Male	02-Female
F-2	Age	10-99 (25)	
F-3	Height	100-200 (170)	
F-4	Weight	20-150 (70)	
F-5	Body Fat	<19	Under weight
		19~25	Ideal weight
		25~29	Over weight
		>29	obesity

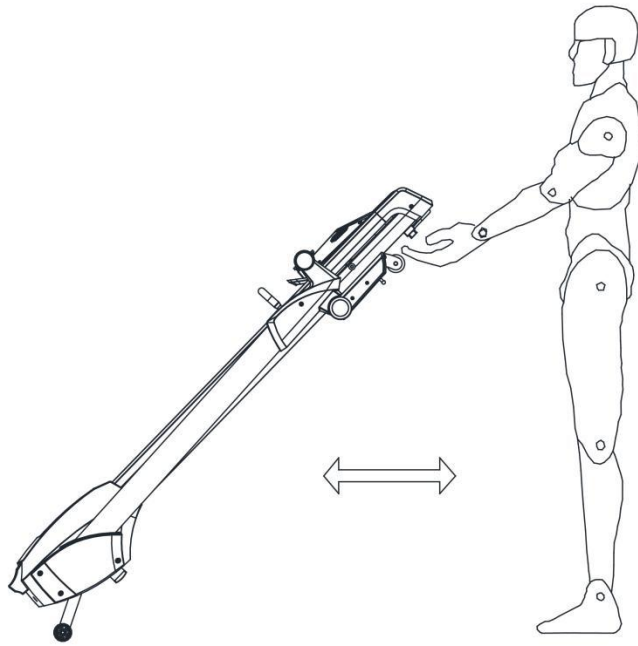

1. Hold the running deck, touch the cylinder joint with your tiptoes to unfold it as shown in the diagram.

Warning!

- A folded treadmill should not be operated.
- Allow the running surface to come to a complete stop before folding.

Care and Maintenance

1. The safety level of the equipment can only be maintained if it is examined regularly for damage and wear e.g. ropes, pulleys and connection points.

2. Lubricate moving parts with light oil periodically to prevent premature wear. Never use abrasives or solvents to clean the treadmill. To prevent damage to the computer, keep liquids away and keep it out of direct sunlight.

3. Inspect and tighten all parts before using the equipment.

Replace defective components immediately and/or keep the equipment out of use until repair.

Pay special attention to components most susceptible to wear.

4. The equipment can be cleaned using a damp cloth and mild non-abrasive detergent. **Do not** use solvents.

5. Do not attempt to repair this equipment yourself. Should you have any difficulty

with assembly, operation or use of your exercise product or if you think that you may have parts missing, contact the manufacturer, their approved service agent or the

Customer Helpline:

0345 600 1714

www.argos-support.co.uk/

Guarantee:

For guarantee purposes, please retain your purchase receipt.

Care and Maintenance

Belt Adjustment

Improper maintenance can cause damage to the treadmill or shorten the life of the product and exceed the LIMITED WARRANTY coverage.

A. *Important:* Never use abrasives or solvents to clean the treadmill. To prevent damage to

the computer, keep liquids away and keep it out of direct sunlight.

B. All parts of the treadmill must be checked and tightened regularly. Worn parts must be replaced immediately.

BELT ADJUSTMENT

You may need to adjust the running belt during the first few weeks of use. All running belts are properly set at the factory. It may stretch or become misaligned following use. Stretching is normal during the break-in period.

ADJUSTING THE BELT TENSION

If the running belt feels as though it is “slipping” or hesitating when you plant your foot during a run, the tension on the running belt may have to be increased.

TO INCREASE THE RUNNING BELT TENSION

STEP 1: Place 6# Allen wrench on the left belt tension bolt. Turn the wrench clockwise 1/4 turn to draw the rear roller and increase the belt tension.

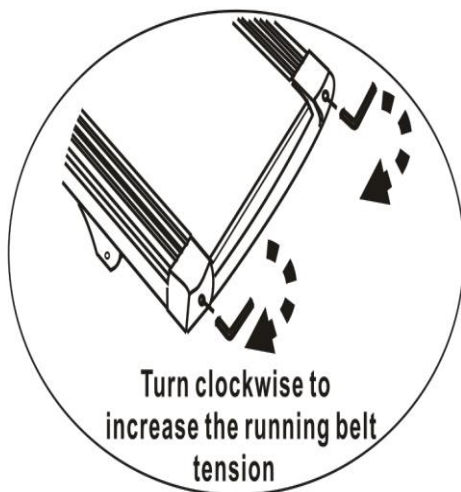

STEP 2: Repeat STEP 1 for the right belt tension bolt. You must be sure to turn both bolts the same number of turns, so the rear roller will stay square relative to the frame.

- C. Repeat STEP 1 and STEP 2 until the slipping is eliminated.
- D. Be careful not to tighten the running belt tension too much as you can create excessive pressure on the front and rear roller bearings. An excessively tightened running belt may damage the roller bearings that would result in bearing noise from the front and rear rollers.

TO DECREASE THE TENSION ON THE RUNNING BELT, TURN BOTH BOLTS COUNTER-CLOCKWISE THE SAME NUMBER OF TURNS.

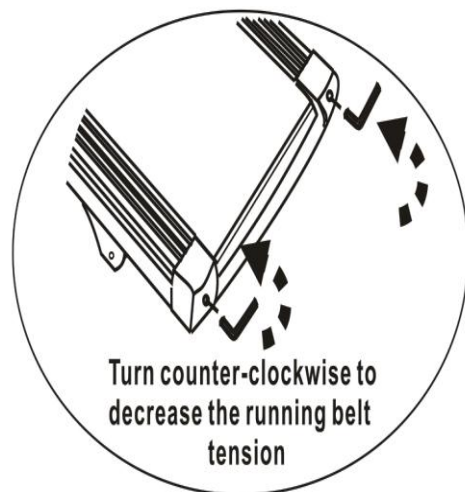

Motor Belt Tension Adjustment

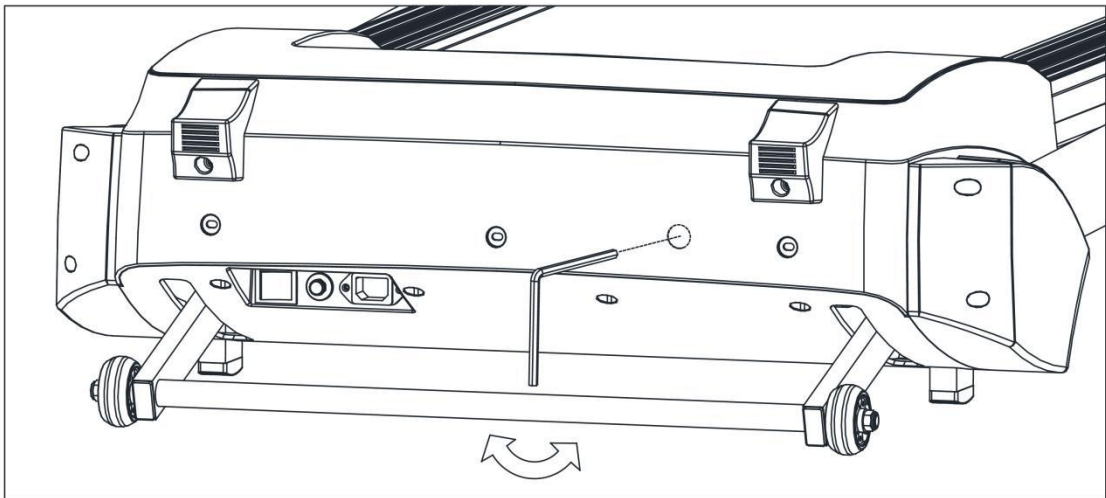

During your workout, if you find the running belt is not running smoothly, that means the motor belt is loosening, please follow the below steps to adjust the motor belt tension:

1. Turn the motor belt adjustment bolt using an M8 Allen wrench 1/4 turn in a clockwise direction.
2. Re-Start the treadmill and run on the treadmill; if the running belt is still not working properly, repeat the above step.

3. Please do not make the motor belt too tight; if the belt is over tightened it will overload the treadmill and reduce the motors life.

The treadmill is pre-lubricated. However, it is recommended to check the lubrication of the treadmill regularly, to ensure optimal operation.

After every 2 months of operation, lift the sides of the treadmill running belt and feel the surface of the deck, as far as possible. If traces of silicon spray are found, lubrication is not necessary. If the surface is dry, refer to the instructions below.

Only use 100% silicon oil to lubricate your treadmill deck.

To apply lubricant on the belt

- Lift the belt at one side and hold the spray valve at a distance of approximately 15cm between the running belt and the deck. Spray from the front to the rear of the deck. Repeat this process on the other side of the belt. Spray each side for about 4 seconds.
- Wait 1 minute to let the silicon spray spread, before starting the machine to circulate the oil over the running deck.

CLEANING

Regular cleaning of the belt ensures a long product life.

- **Warning:** The treadmill must be turned off to avoid electric shocks. The power cord must be pulled out of the socket, before starting the cleaning or maintenance.
- **Caution:** Do not use any abrasives or solvents. To avoid damage to the computer, keep any liquids away. Do not expose the computer to direct sunlight.
- **After each training:** Wipe the console and other surfaces with a clean soft and damp cloth to remove sweat residues.
- **Weekly:** To make cleaning easier, it is recommended to use a mat under the treadmill. Shoes can leave dirt on the belt that can fall beneath the treadmill. Clean the mat under the treadmill once a week.

STORAGE

Store your treadmill in a clean and dry environment. Ensure the master power switch is off and is un-plugged from the electrical wall outlet.

Care and Maintenance

Trouble Shooting

Check		Solution
E00	Safety Key not in position	Re-locate the safety key into the front of the console
E01	Communication error (controller not receives console signal)	A: Check speed signal wire if connected properly B: Replace the speed signal wire C: Replace the driver
E02	Stalling protection	A: Re-insert the motor wire or replace motor B: Replace driver C: Stop use and ask electrician for trouble shooting
E03	No speed sensor signal	A: Re-insert the speed signal wire or replace sensor B: Replace driver
E05	Over current protection	A: System protection and re-start the system B: Adjust transmission part or add lubrication oil C: Replace motor

		D: Replace driver
E10	Motor peak	Adjust the torsion potentiometer to an appropriate position
E13	Communication error (console not receives controller signal)	A: Replace console B: Replace driver

Exploded Parts Diagram



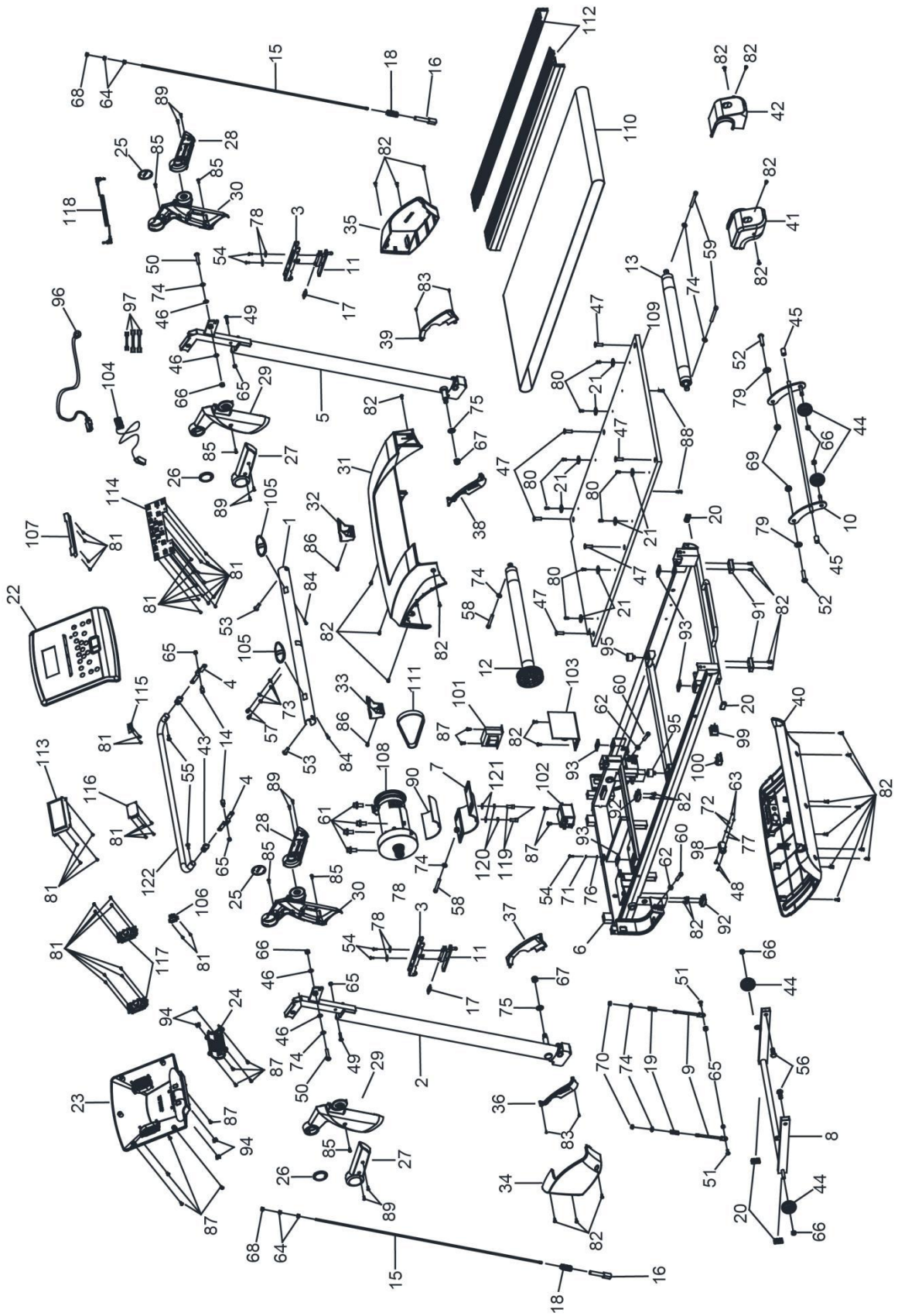

27 Parts List

Part #	Description	QTY	Part #	Description	QTY
1	Handrail Bar	1	62	M8 Nut	2
2	Left Console Mast	1	63	M3 Nut	2
3	Handle	2	64	M5 Hex Nut	4
4	Connector	2	65	M6 Aircraft Nut	6
5	Right Console Mast	1	66	M8 Aircraft Nut	6
6	Running Stage	1	67	M12 Aircraft Nut	2
7	Motor Support	1	68	M5 Aircraft Nut	2
8	Base Frame	1	69	M10 Aircraft Nut	2
9	Spring Rod	2	70	M6 Flange Lock Nut	2
10	Incline Adjustment Frame	1	71	Φ4 Spring Washer	1
11	Sliding Pin Plate	2	72	Φ3 Spring Washer	2
12	Front Roller	1	73	Φ6 Washer	4
13	Rear Roller	1	74	Φ8 Washer	8
14	Step Bolt	2	75	Φ12 Washer	2
15	Thread Rod	2	76	Φ4 Washer	1
16	Thread Rod Base	2	77	Φ3 Washer	2
17	Φ10×Φ1.2×42 Tension Spring	2	78	Φ20 x Φ4 x1Bigger Washer	4
18	Φ16.5×Φ2×45 Compressed Spring	2	79	Φ25 x Φ11x2 Plastic Washer	2
19	Φ11×Φ1.5×66 Compressed Spring	2	80	ST4.8 x 15mm Phillips Screw (Z)	8
20	End Cap	4	81	ST2.9 x 8mm Phillips Screw	40
21	Side Rail Fixer	8	82	ST4.8 x 15mm Phillips Screw	34
22	Console Upper Housing	1	83	ST2.9 x 10mm Phillips Screw	4
23	Console Bottom Housing	1	84	ST4.2 x 25mm Phillips Screw	2
24	Console Rotate Cover	1	85	ST4.2 x 15mm Phillips Screw	6
25	Handrail Decoration Cap	2	86	ST4.8 x 20mm Phillips Screw	2
26	Handrail Decoration Ring	2	87	ST4.2 x 15mm Phillips Screw	13
27	Left Handle Cover	2	88	ST4.2 x 30mm Sunk Screw	2
28	Right Handle Cover	2	89	ST4.2 x 15mm Sunk Screw	8

29	Left Handrail Cover	2	90	Motor Base	1
30	Right Hnadrail Cover	2	91	Shock Pad	2
31	Motor Cover	1	92	Air Cushion	2
32	Left Ground Support	1	93	Running Deck Bumper	4
33	Right Ground Support	1	94	Damper Pad	4
34	Left Console Mast Cover	1	95	Rubber Cushion	2
35	Right Console Mast Cover	1	96	Power Cord	1
36	Left Console Mast Decoration (L)	1	97	Short Cord	1
37	Left Console Mast Decoration (R)	1	98	Power Socket	1
38	Right Console Mast Decoration (L)	1	99	Power Swtich	1
39	Right Console Mast Decoration (R)	1	100	Over Current Protector	1
40	Motor Bottom Cover	1	101	Inductor	1
41	Left End Cap	1	102	Filter	1
42	Right End Cap	1	103	Driving Board	1
43	Plug	2	104	Safety Key	1
44	Transport Wheel	4	105	Handle Grip	1
45	Nylon Sleeve	2	106	Insert Switch	1
46	Φ15.5×Φ8×0.8 Plastic Washer	4	107	IPAD Holder	1
47	M8 x 24mm Sunk Bolt	6	108	Motor	1
48	M3 x 12mm Sunk Bolt	2	109	Running Deck	1 ²⁸
49	M6 x 27mm Allen Bolt	2	110	Running Belt	1
50	M8 x 40mm Allen Bolt	2	111	Motor Belt	1
51	M6 x 15mm Allen Bolt	2	112	Side Rail	2
52	M10 x 40mm Allen Bolt	2	113	LCD Screen	1
53	M8 x 25mm Allen Bolt	2	114	PCB Board	1
54	M4 x 10mm Phillips Bolt	5	115	MP3 Module	1
55	M6 x 15mm Phillips Bolt	2	116	Power Amplifier	1
56	M10 x 25mm Hex Bolt	2	117	Speaker	2
57	M6 x 12mm Cylinder Head Bolt	2	118	MP3 Connection	1
58	M8 x 60mm Cylinder Head Bolt	2	119	M8×16mm Hex Bolt	2
59	M8 x 70mm Cylinder Head Bolt	2	120	Φ8 Spring Washer	2
60	M8 x 30mm Cylinder Head Bolt	2	121	Φ8 Washer	2

61 M10 x 25mm Cylinder Head Bolt

4 122 Lifting Bar

1

Guarantee



Product Guarantee

This product is guaranteed against manufacturing defects from a period of



Year

This product is guaranteed for twelve months of original purchase. Any defect that arises due to faulty materials or workmanship will either be replaced, refunded or repaired free of charge where possible during this period by the dealer from whom you purchased the unit.

The guarantee is subject to the following provisions:

- The guarantee does not cover accidental damage, misuse, cabinet parts, knobs or consumable items.

