

# MONTAGEANLEITUNG

## ASSEMBLY INSTRUCTIONS

### INSTRUCTION DE MONTAGE

#### OPBOUW HANDLEIDING

#### ISTRUZIONI DI MONTAGGIO

Technische und optische Änderungen vorbehalten.  
 Under reservation of technical and optical changes.  
 Avec le droit de modifier des details technique et visuel.  
 Technische en optische veranderingen voorbehouden.  
 Ci riserviamo per eventuali variazioni tecniche.

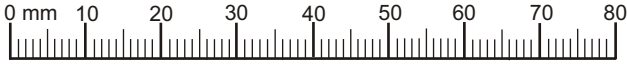

Hiermit können Sie die mitgelieferten Schrauben nachmessen.  
 To measure the delivered screws herewith.  
 Pour mesurer les vis livrées avec.  
 Om de nageleverde schroeven na te meten.  
 Verificare la ferramenta fornita.

<b>A</b> 	<b>B</b>  8 x 30	<b>C</b> 	<b>D</b> 	<b>E</b> 
12	12	15	3	3
<b>F</b>  3,5 x 16	<b>G</b> 	<b>H</b> 	<b>I</b> 	<b>J</b> 
6	3	6	3	1
<b>K</b> 	<b>L</b>  4 x 17	<b>M</b> 	<b>N</b> 	<b>O</b> 
1	1	2	20	20

<b>P</b> 	<b>Q</b>  3,5 x 20
4	4

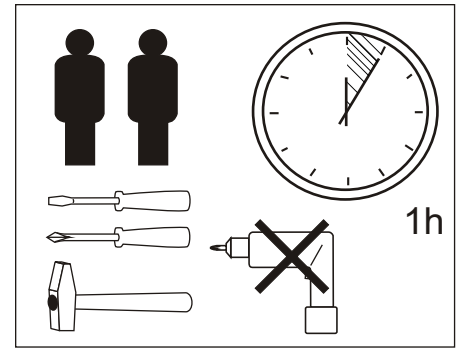
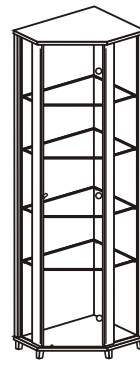

0104483 - 1 / E.N. - 05.06.07

## Trio

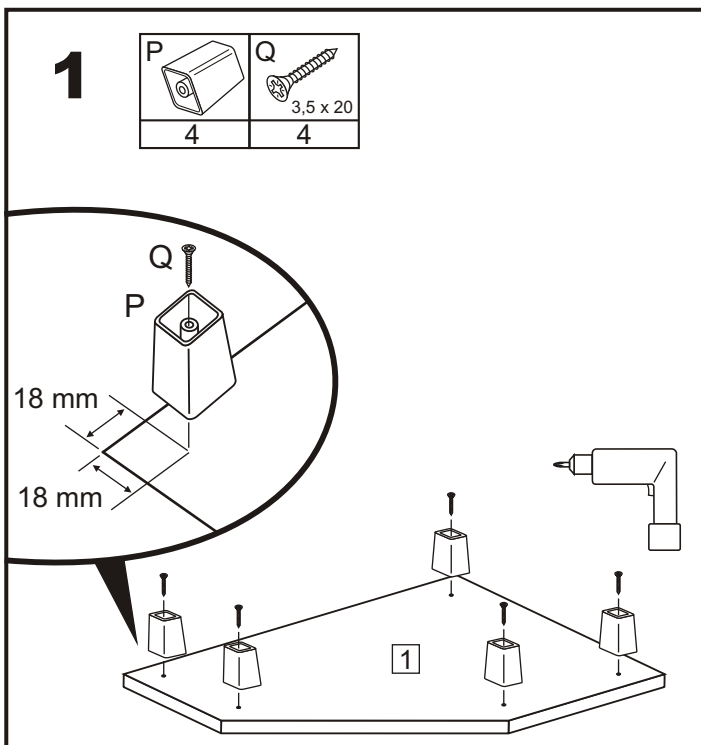
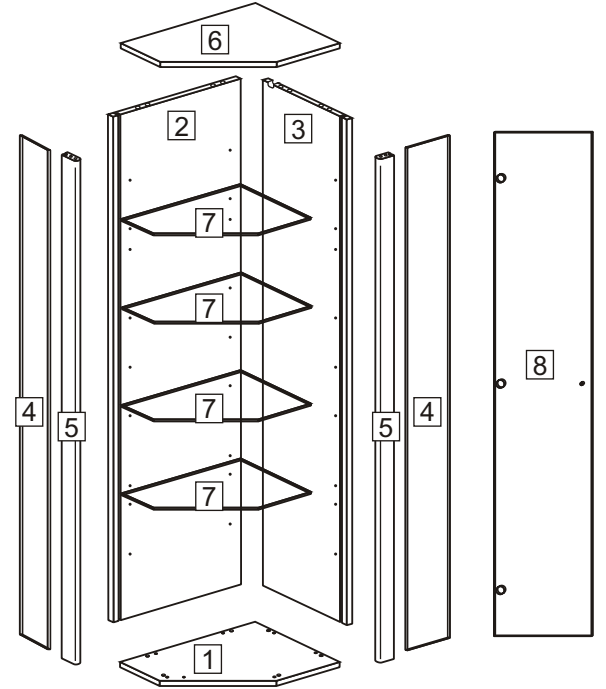

## 2

- Wenn Sie separat eine Beleuchtung gekauft haben, bitte jetzt wie folgt montieren.
- When you have bought a lamp separate, please assemble as follow now.
- Si vous avez acheter un éclairage séparément, veuillez procéder au montage de la manière suivante.
- Indien U de verlichting gescheiden hebt gekocht, nu s.v.p. als volgt monteren.
- Quando hai comprato una lampada a parte, si prega assemblarla come riportato di seguito.

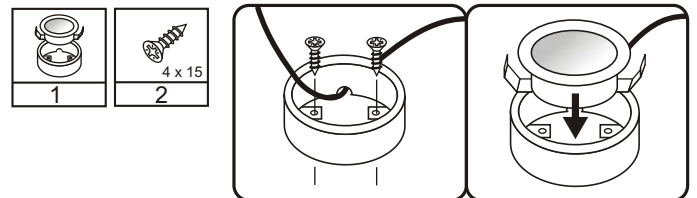

Oberboden  
cover plate  
dessus  
bovenplaat  
parte superiore

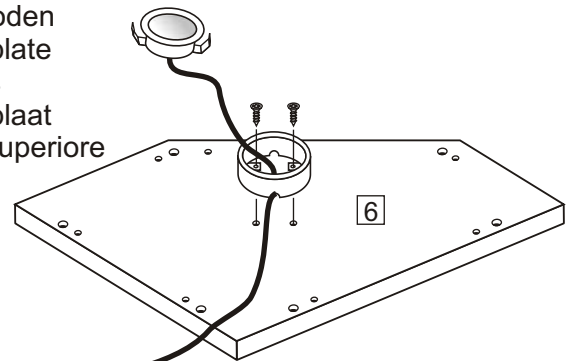

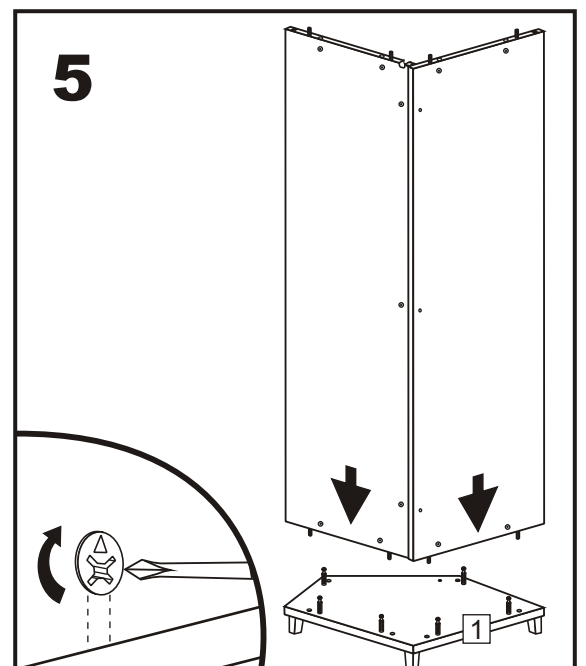
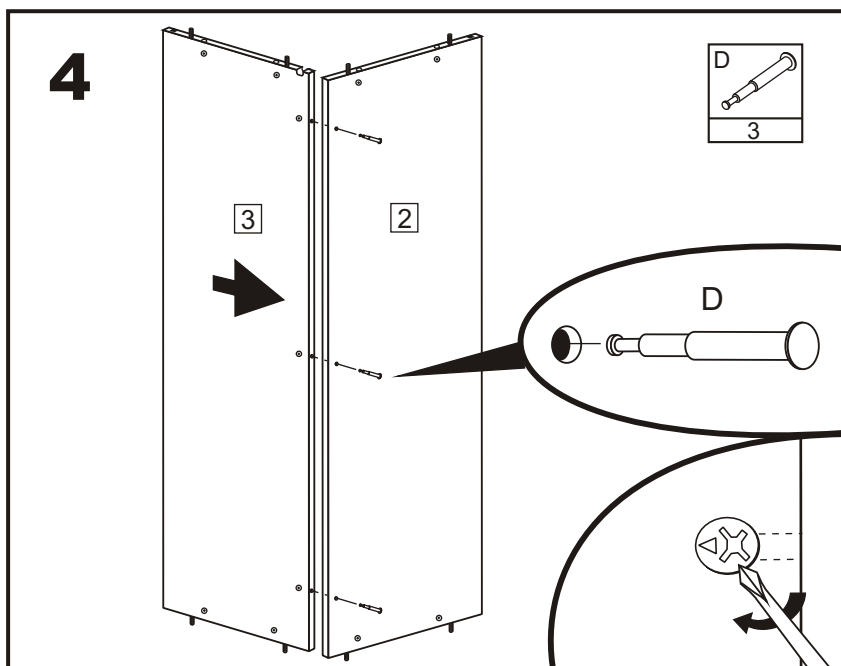
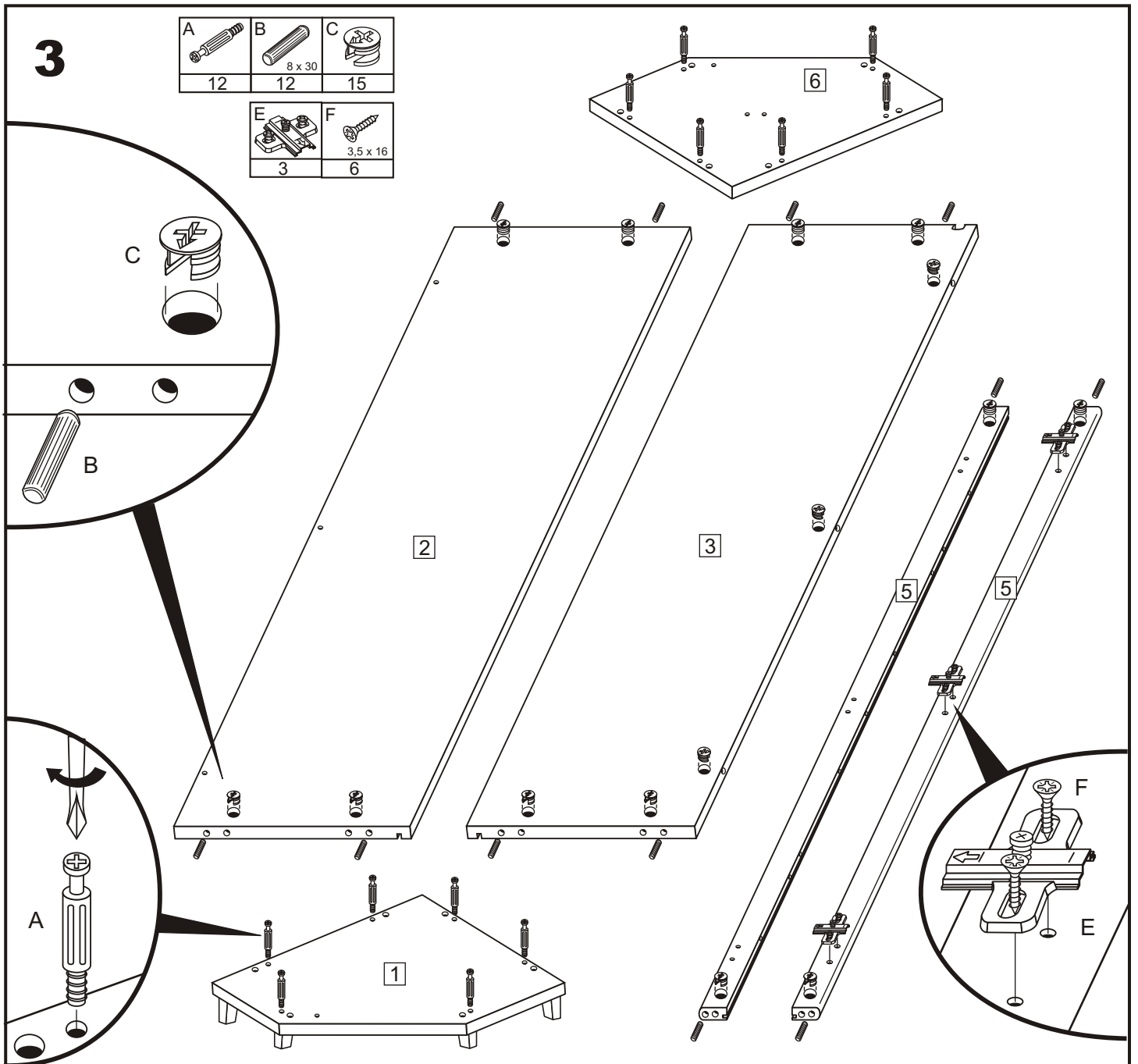

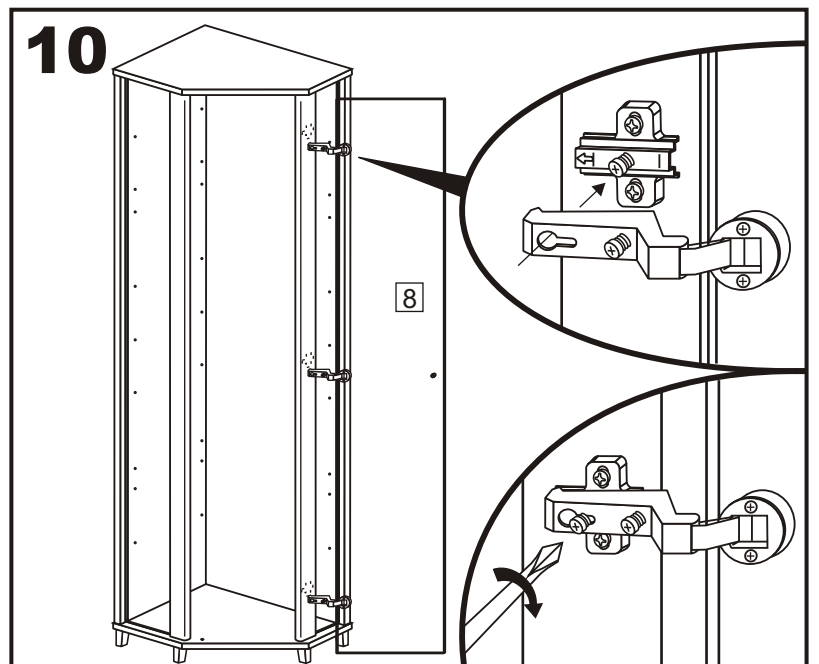
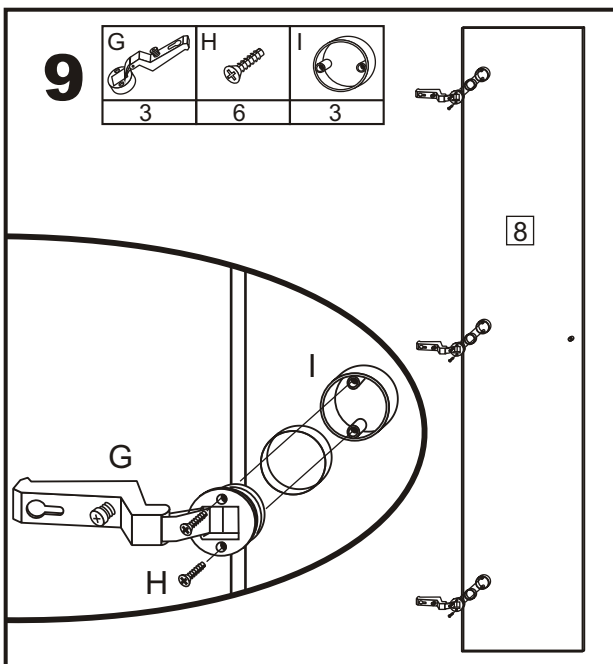
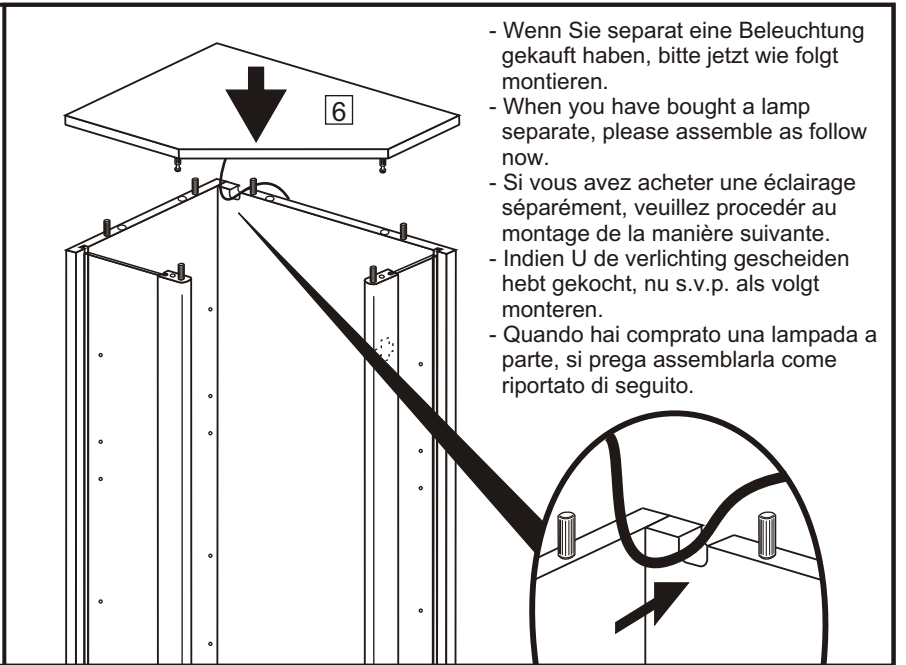
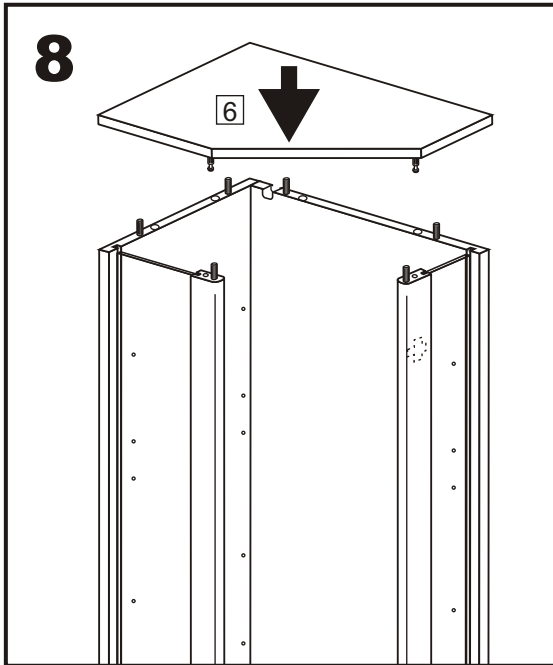
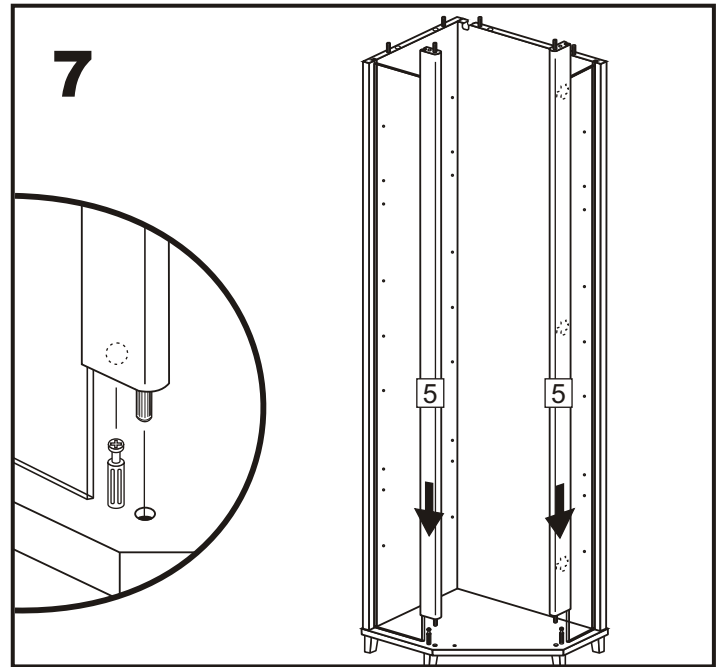
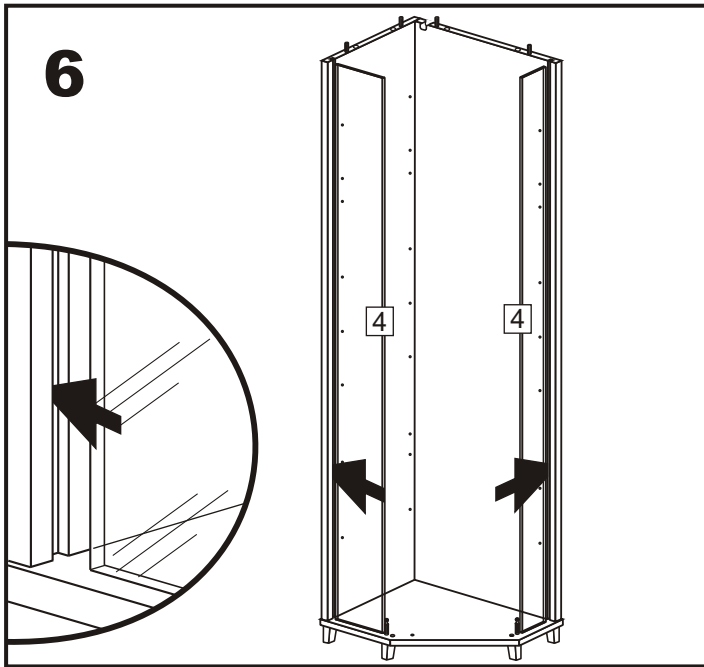

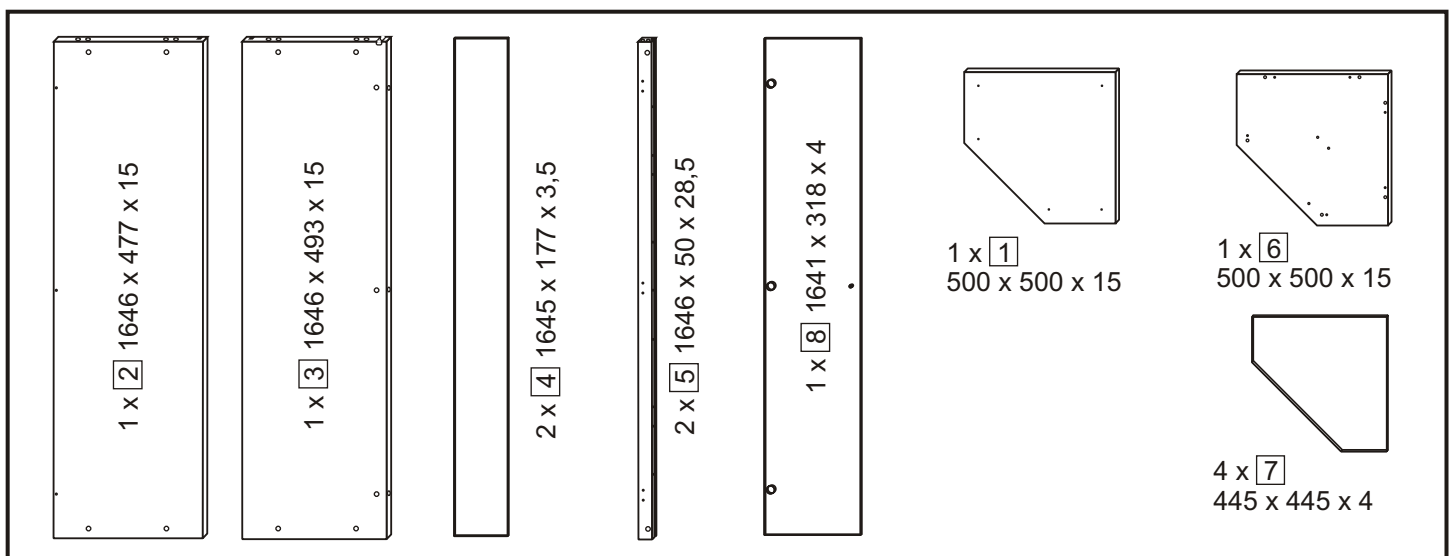
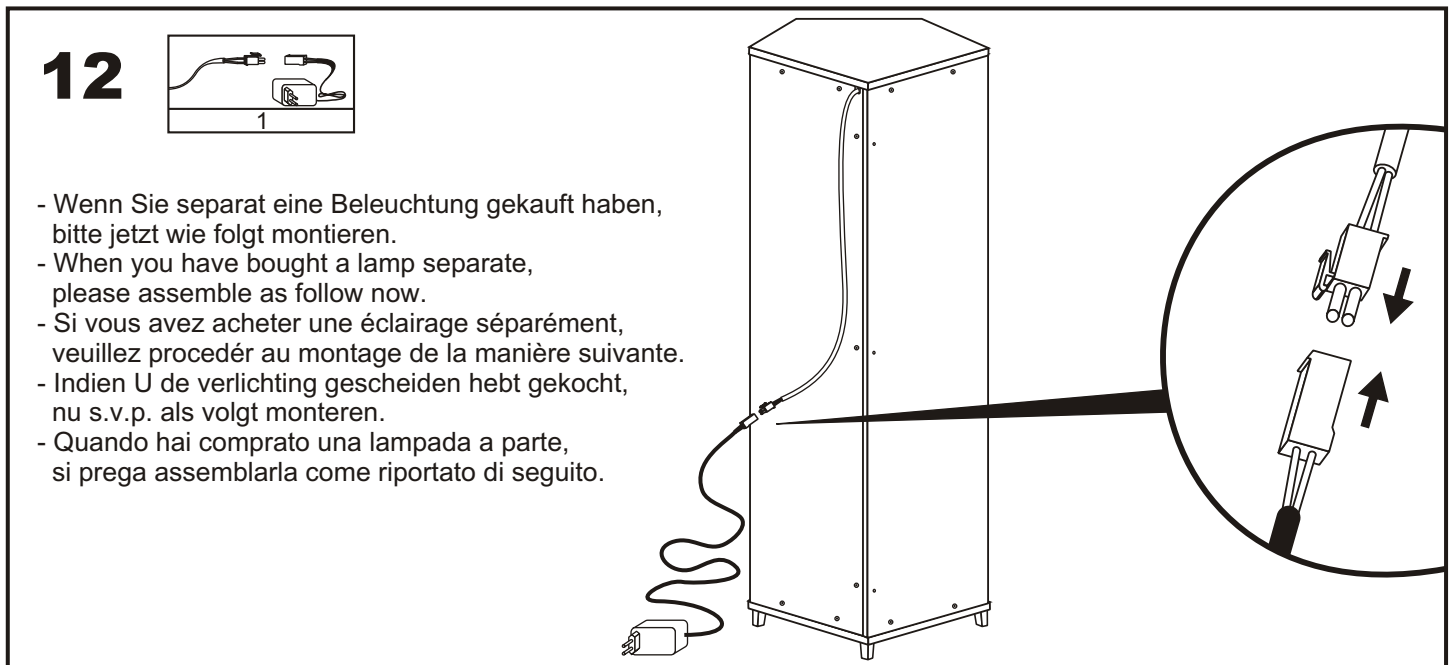
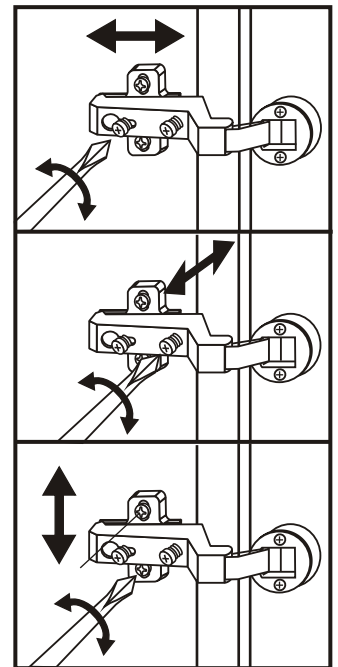
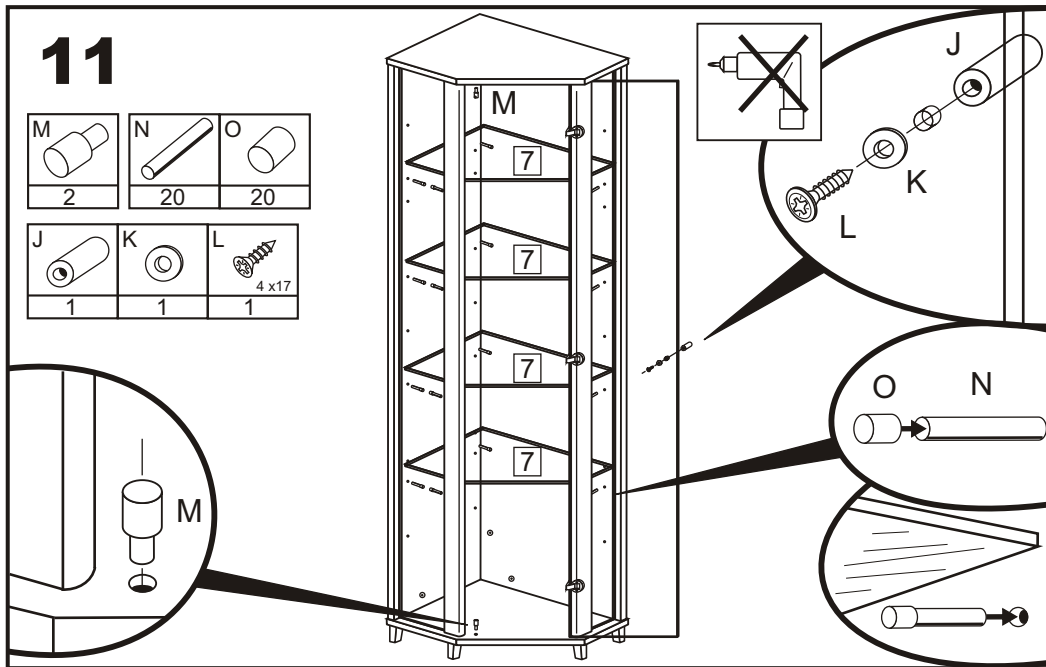

**Pflegehinweis:** Aluminium-, Glas- und Lackoberflächen sind pflegeleicht. Zum Reinigen genügt das Abwischen mit einem feuchten Tuch oder etwas Seifenlauge.

**After care:** To clean the surfaces please use a soft humid cloth and if necessary with some soap.

# MONTAGEANLEITUNG

## ASSEMBLY INSTRUCTIONS

### INSTRUCTION DE MONTAGE

### OPBOUW HANDLEIDING

### ISTRUZIONI DI MONTAGGIO

0104755 - 1 / E.N. - 23.01.10

Technische und optische Änderungen vorbehalten.  
 Under reservation of technical and optical changes.  
 Avec le droit de modifier des details technique et visuel.  
 Technische en optische veranderingen voorbehouden.  
 Ci riserviamo per eventuali variazioni tecniche.

**Pflegehinweis:** Aluminium-, Glas- und Lackoberflächen sind pflegeleicht. Zum Reinigen genügt das Abwischen mit einem feuchten Tuch oder etwas Seifenlauge.

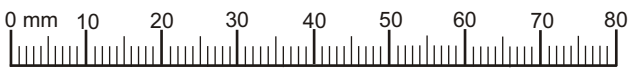

Hiermit können Sie die mitgelieferten Schrauben nachmessen.  
 To measure the delivered screws herewith.  
 Pour mesurer les vis livrées avec.  
 Om de nageleverde schroeven na te meten.  
 Verificare la ferramenta fornita.

<b>B</b> 	<b>C</b> 	<b>D</b> 	<b>E</b> 	<b>F</b> 
12	12	14	2	3
<b>G</b> 	<b>H</b> 	<b>I</b> 	<b>J</b> 	<b>K</b> 
6	3	6	3	1
<b>L</b> 	<b>M</b> 	<b>N</b> 	<b>O</b> 	<b>P</b> 
1	1	2	20 / 35	20 / 35

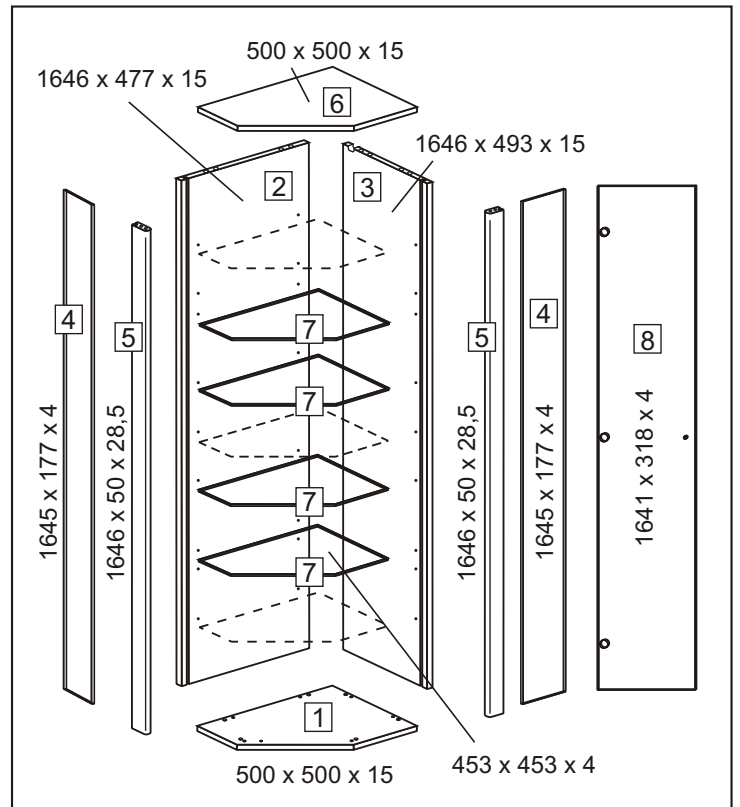
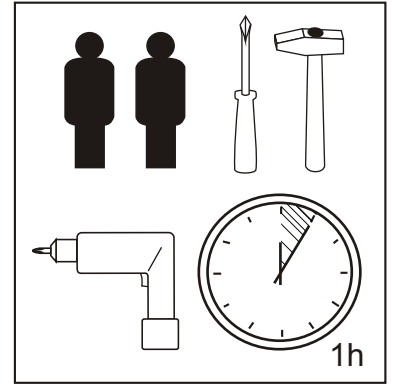
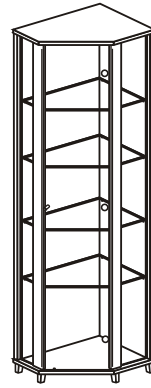

### 1a

18 mm  
18 mm

### 1b

40 mm  
40 mm

**ACHTUNG: TYP DES FUSSES HÄNGT VOM MODELL AB.**  
**ATTENTION: TYPE OF GLIDES DEPENDING ON MODELL.**  
**PAS OP: VORM VAN DE POTEN HANGT VAN HET MODELTYPE AF.**  
**ATTENTION: LE MODÈLE DE PIEDS DÉPEND DU TYPE DE VITRINE.**  
**ATENZIONE: IL TIPO DIE PIEDI VARIA DAL MODELLO**

**2**

- Wenn Sie separat eine Beleuchtung gekauft haben, bitte jetzt wie folgt montieren.
- When you have bought a lamp separate, please assemble as follow now.
- Si vous avez acheter une éclairage séparément, veuillez procéder au montage de la manière suivante.

- Indien U de verlichting gescheiden hebt gekocht, nu s.v.p. als volgt monteren.
- Quando hai comprato una lampada a parte, si prega assemblarla come riportato di seguito.

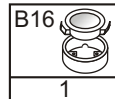
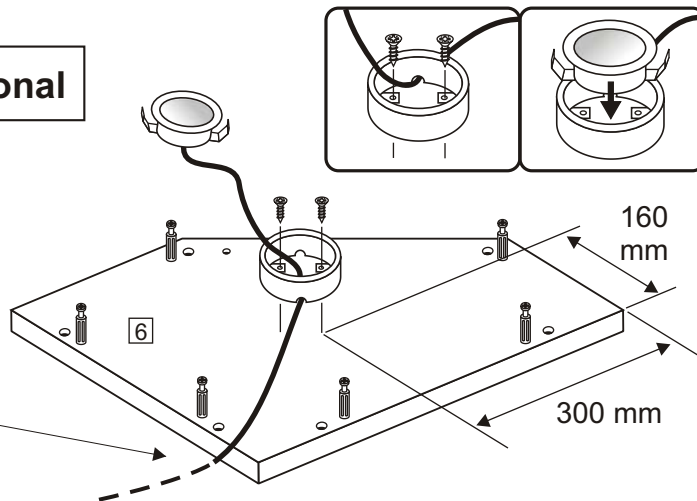
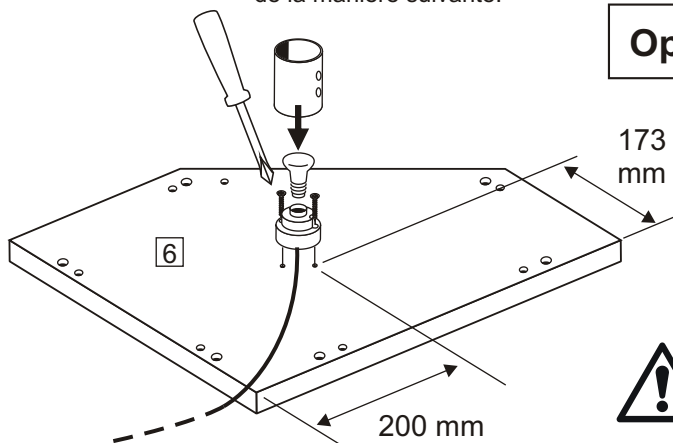
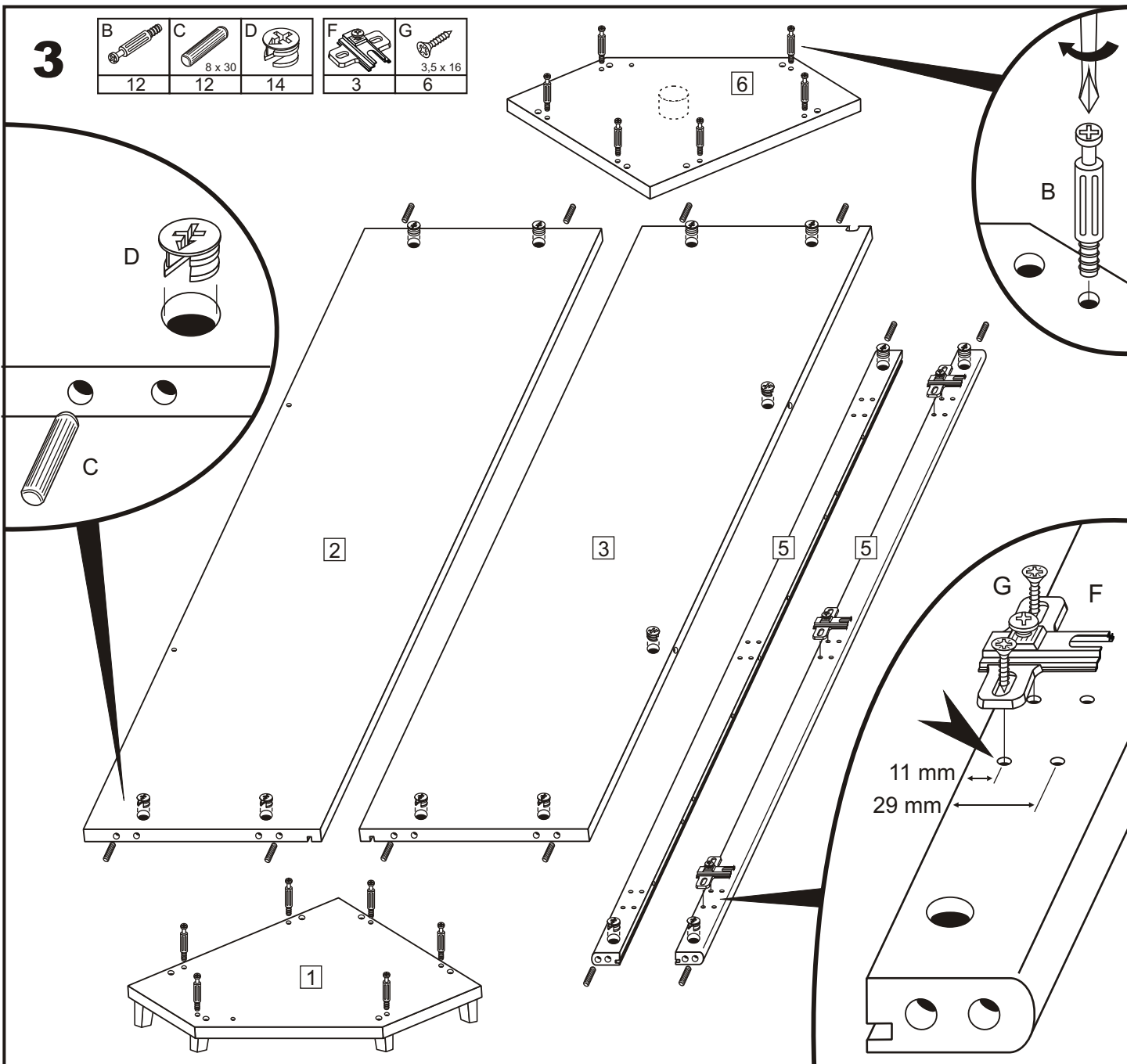
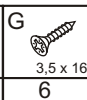
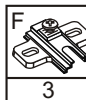
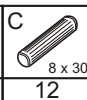
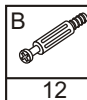
**Optional****3**

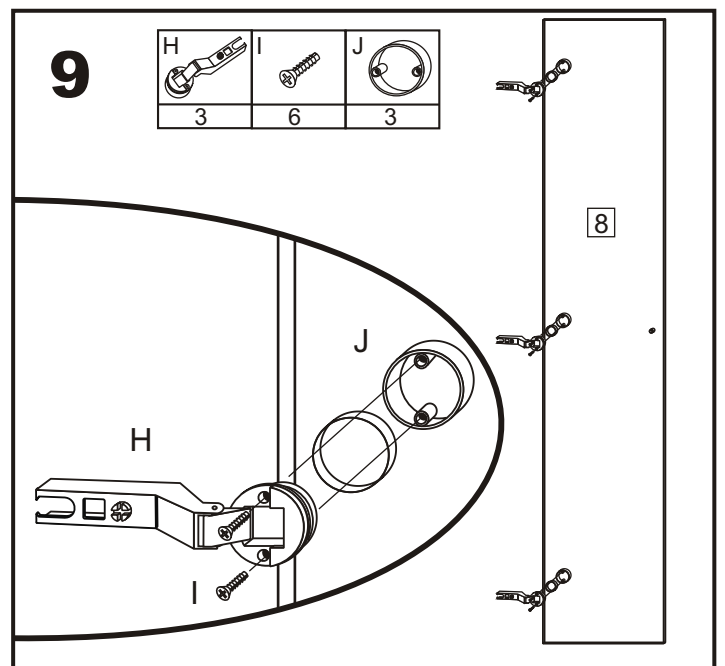
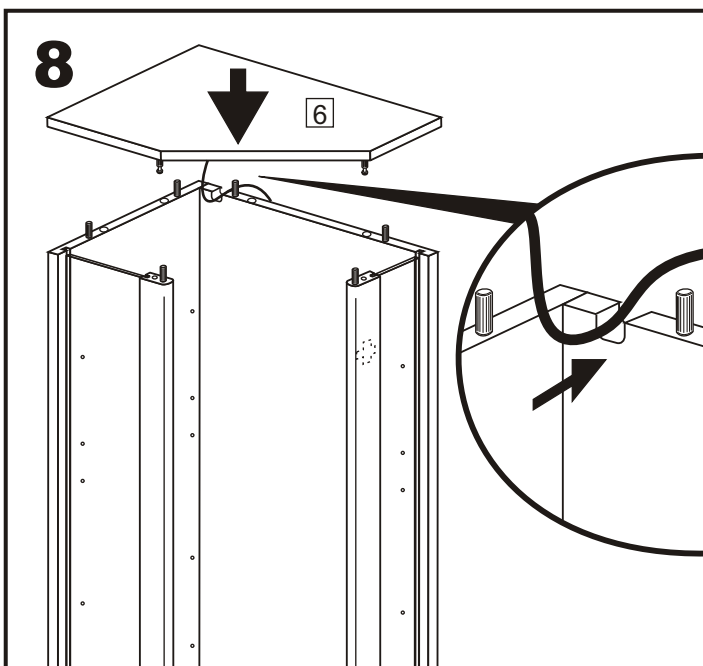
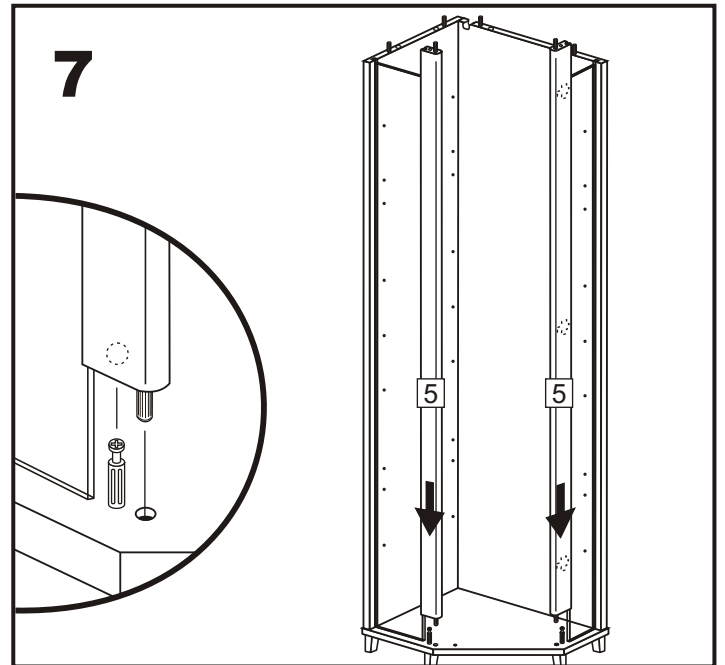
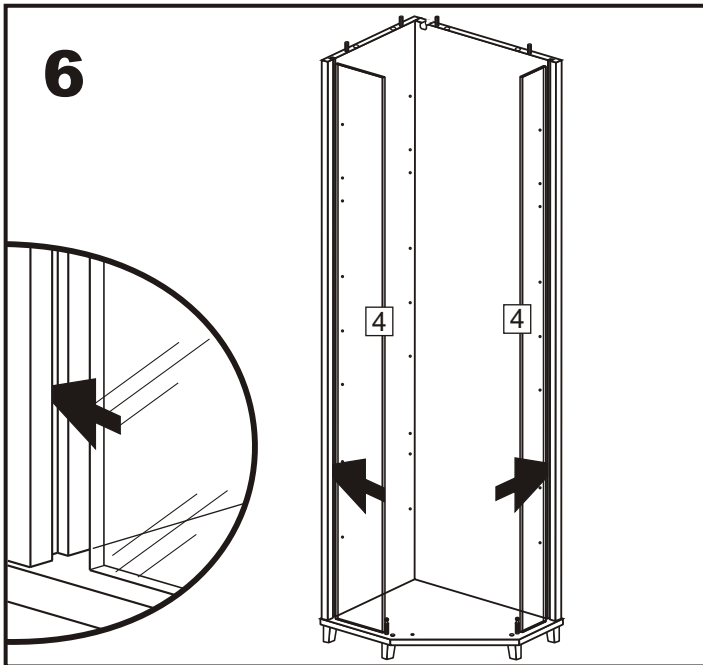
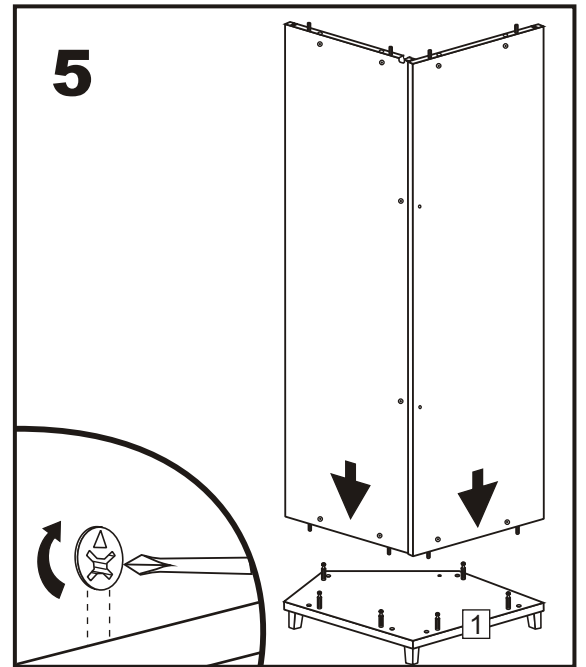
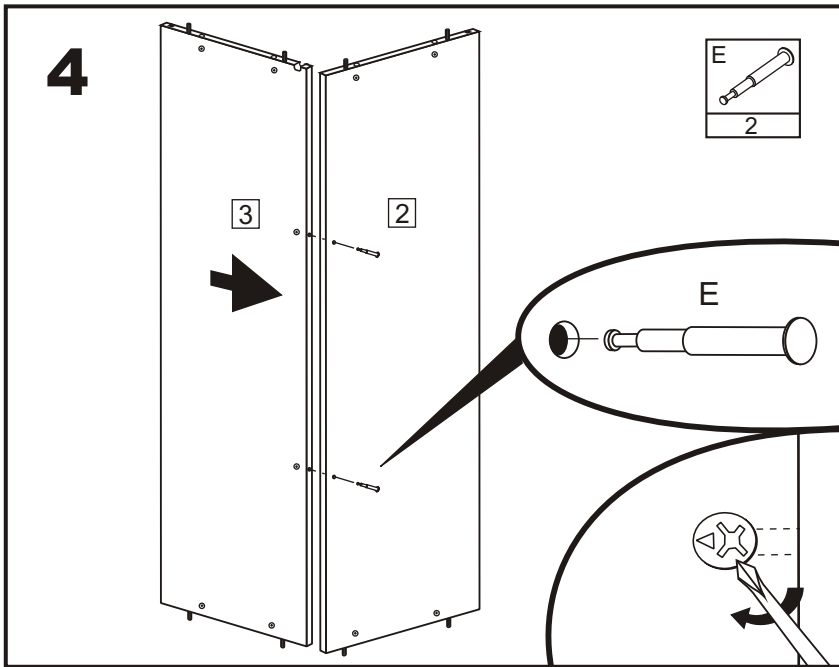



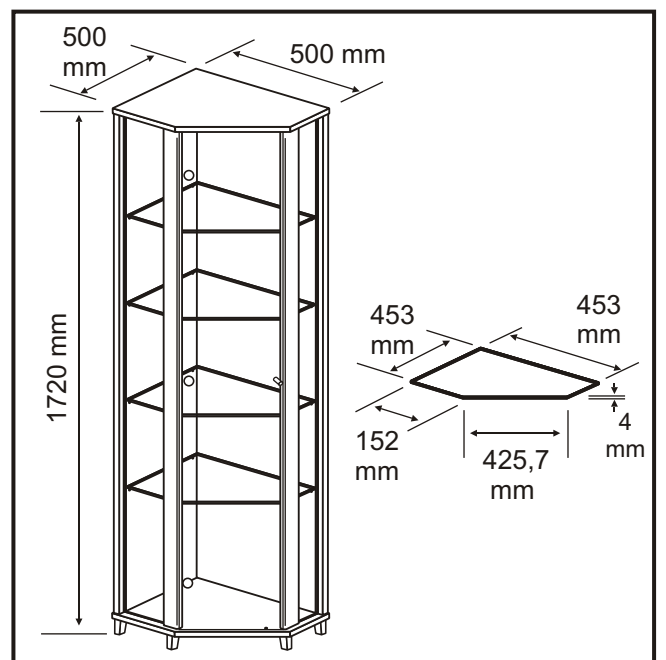
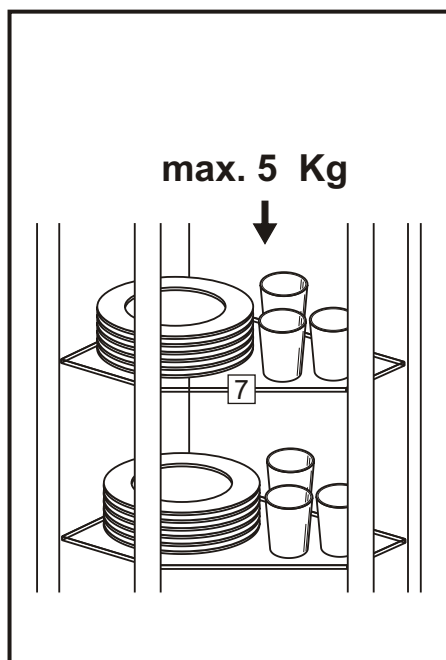
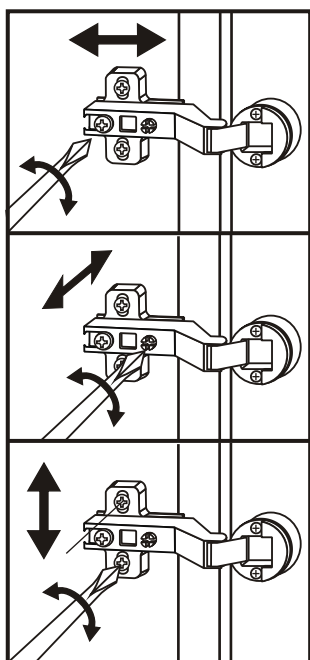
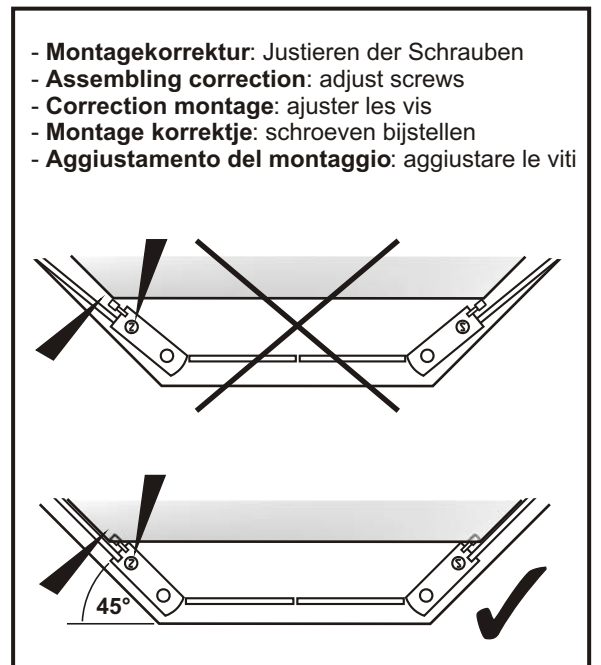
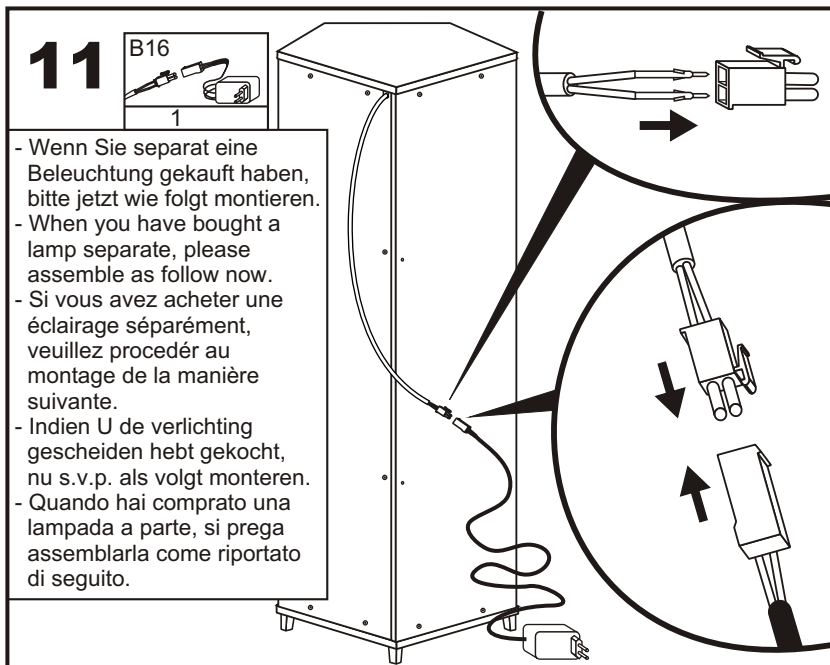
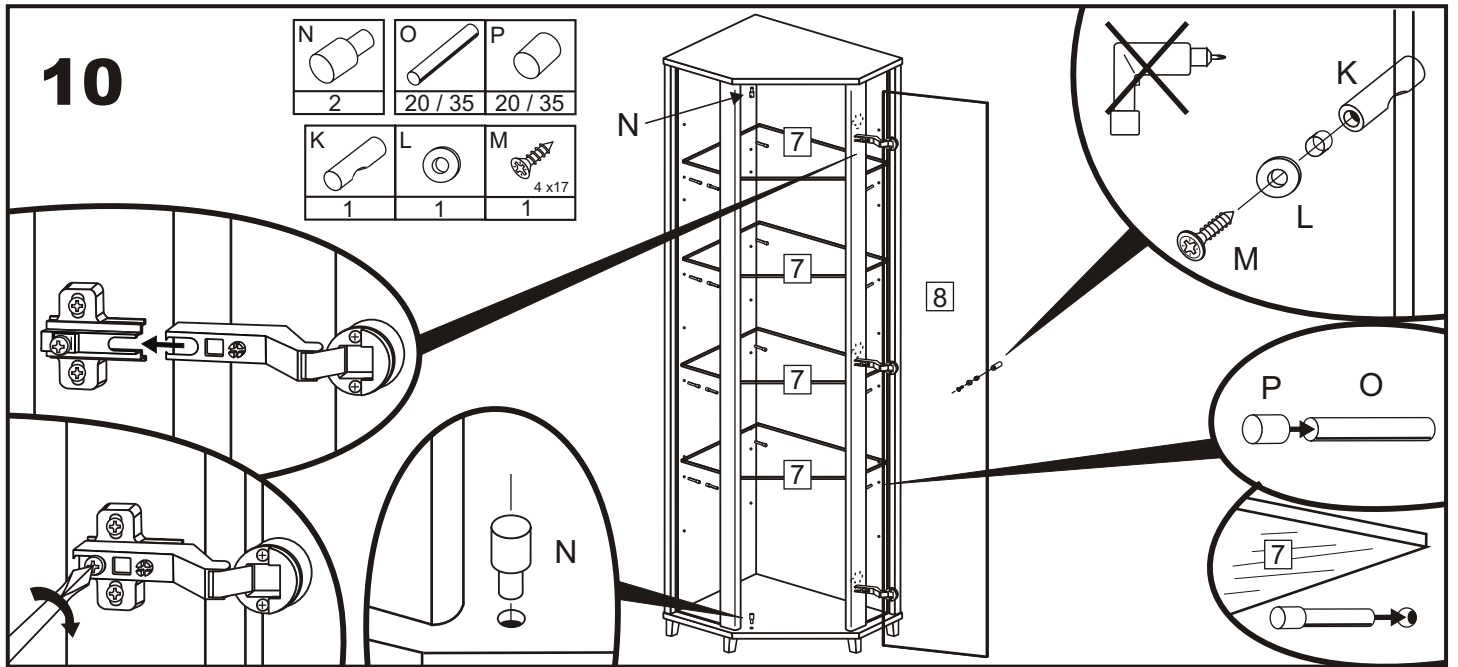



# SERVICEKARTE

Modellname:

Artikel-Nr.:

Type: (falls vorhanden)











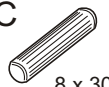



Farb-Nr.: (falls vorhanden)



Liebe Kundin, lieber Kunde,



obwohl wir unsere Möbel vor der Auslieferung einer eingehenden Endkontrolle unterziehen, kann es vorkommen, dass einmal ein Zubehörteil fehlt oder dass ein Teil während des Transports beschädigt wird. **Senden Sie den Artikel in so einem Fall bitte nicht zurück**, sondern fordern Sie einfach Ersatz für das fehlende bzw. beschädigte Teil bei unserer **Kunden-Hotline** an. Die Telefonnummer finden Sie auf den Serviceseiten im aktuellen Katalog.

Bitte nennen Sie bei der Ersatzteilbestellung **Modellnamen, Artikelnummer, Type und Farbnummer** des Möbelstückes sowie die benötigten **Ersatzteilnummern / -bezeichnungen**, wie sie in dieser Anleitung angegeben sind.

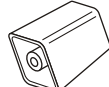
Wir werden Ihre Anforderungen sofort bearbeiten und Ihnen das Ersatzteil umgehend zusenden.

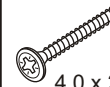
<b>B</b>  12	<b>C</b>  8 x 30 12	<b>D</b>  14	<b>E</b>  2	<b>F</b>  3
<b>G</b>  3,5 x 16 6	<b>H</b>  3	<b>I</b>  6	<b>J</b>  3	<b>K</b>  1
<b>L</b>  1	<b>M</b>  4 x 17 1	<b>N</b>  2	<b>O</b>  20 / 35	<b>P</b>  20 / 35

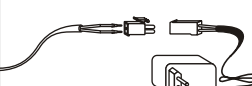
 5	 3,5 x 20 5	 5	 4,0 x 25 5
---	--	--	--

<b>B16</b>  1	 1	 4 x 15 2
--	---	---

<b>B10</b>  1
---

Bitte füllen Sie diese Servicekarte sorgfältig aus, damit Sie alle nötigen Daten bei Ihrer Ersatzteilbestellung zur Hand haben. Die Telefonnummer der Bestellannahme finden Sie in Ihrem aktuellen Katalog.

Modellname: .....

Tel. für Rückfragen: .....

Artikel-Nr.: .....

Grund der Ersatzteilanforderung: .....

Type: .....

Farb-Nr.: .....

Kundennummer: .....

Benötigte Teile:

Name: .....

Teile-Nr.	Bezeichnung	Anzahl

Straße: ..... Haus-Nr.: .....

PLZ: ..... Ort: .....

Rechnungsdatum: .....