

Verona Coffee Table

Assembly Instructions - Please keep for future reference

609/5033

610/6812

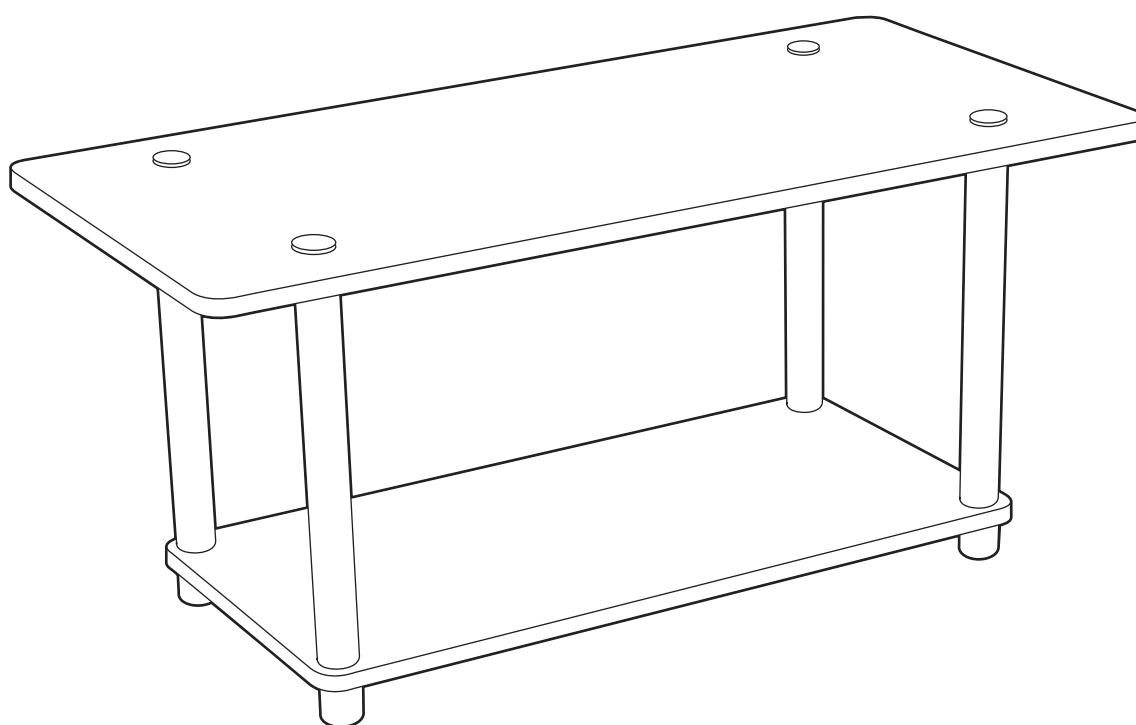

Dimensions

Width - 90cm

Depth - 45cm

Height - 41cm

Important - Please read these instructions fully before starting assembly

If you need help or have damaged or missing parts, call the **Customer Helpline: 08456 400800**



Safety and Care Advice

Important - Please read these instructions fully before starting assembly

- Check you have all the components and tools listed on pages 2 and 3.
- Remove all fittings from the plastic bags and separate them into their groups.
- Keep children and animals away from the work area, small parts could choke if swallowed.
- Make sure you have enough space to layout the parts before starting.

- Do not stand on the panels, this could cause damage.
- Assemble the unit as close to its final position (in the same room) as possible.
- Assemble on a soft level surface to avoid damaging the unit or your floor.
- Parts of the assembly will be easier with 2 people.



- We do not recommend the use of power drill/ drivers **for inserting screws**, as this could damage the unit. Only use hand screwdrivers.
- Dispose of all packaging carefully and responsibly.
- **Warning:** The unit weighs approximately 7.4kgs. **Please lift with care.**

Care and maintenance

- Only clean using a damp cloth and mild detergent, do not use bleach or abrasive cleaners.
- From time to time check that there are no loose screws on this unit.
- This product should not be discarded with household waste. Take to your local authority waste disposal centre.

Components - Panels

If you have damaged or missing components, call the **Customer Helpline:08456 400800**

Please check you have all the panels listed below



1 Table top (90 x 45cm)

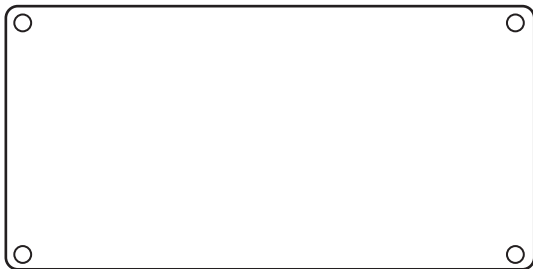

2 Shelf (70 x 35cm)



3 Post x 4 (37.1 x Ø3.5cm)

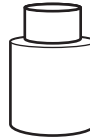

4 Foot x 4 (4.7 x Ø3.4cm)

Components - Fittings

Please check you have all the fittings listed below

Note: The quantities below are the correct amount to complete the assembly. In some cases more fittings may be supplied than are required.

<p>A Cap screw x 4 Pre-assembled at 4</p> 		
---	--	--

Assembly Instructions

Step 1

Fitting the legs

a: Unscrew Cap screws **A** from the Feet **4**.

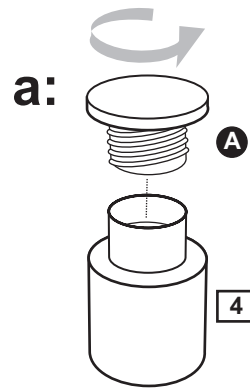

b: Use Legs **3** to fix the Feet **4** onto the Shelf **2**.

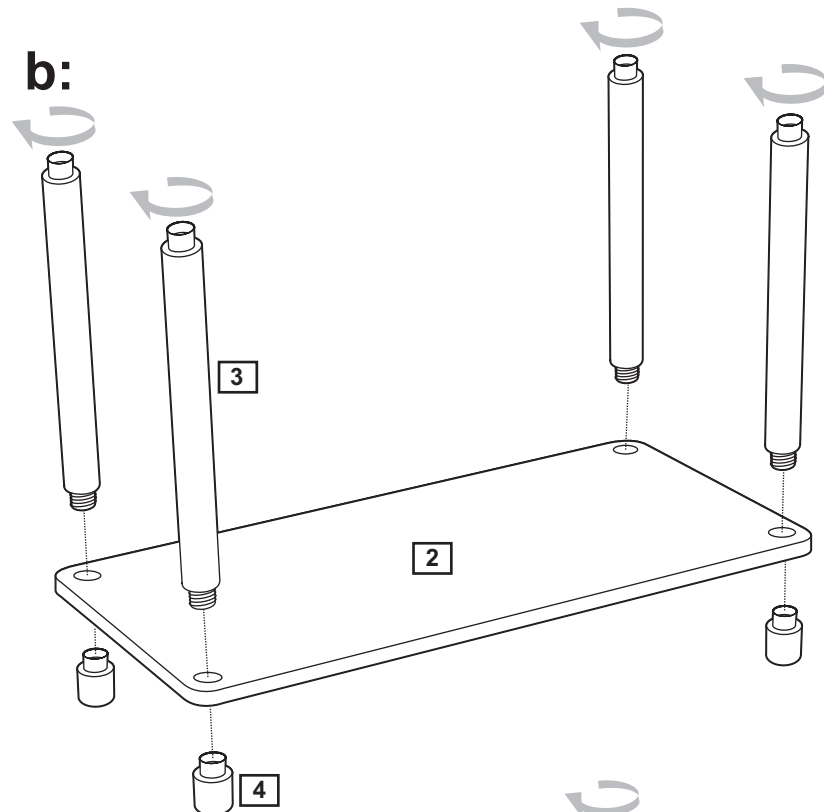

c: Use Cap screws **A** to fix the Top panel **1** onto the unit.

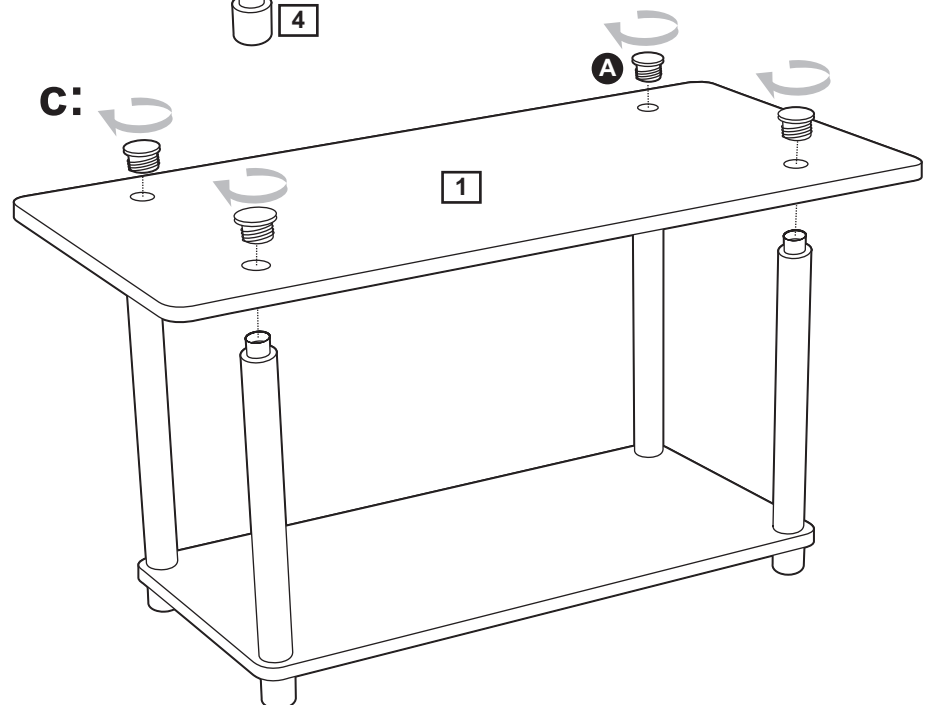

Assembly Instructions

Step 2

Finishing the unit

Finally place the unit in the desired location.

Note: Before use always make sure the unit is secure.

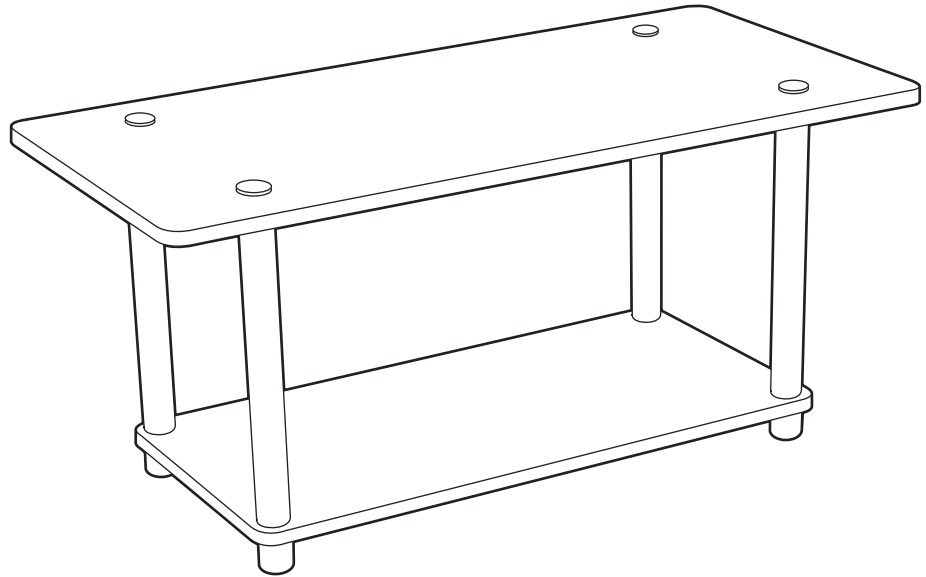

Assembly is complete.

If you need help or have damaged or missing parts, call the **Customer Helpline : 08456 400800**

Components

Ⓐ 1 x Table Top



Ⓑ 1 x Shelf



Ⓓ 4 x Foot

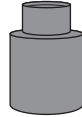

Ⓒ 4 x Leg



Verona Beech / Silver Coffee Table

Simple Assembly Instructions - Please keep for future reference

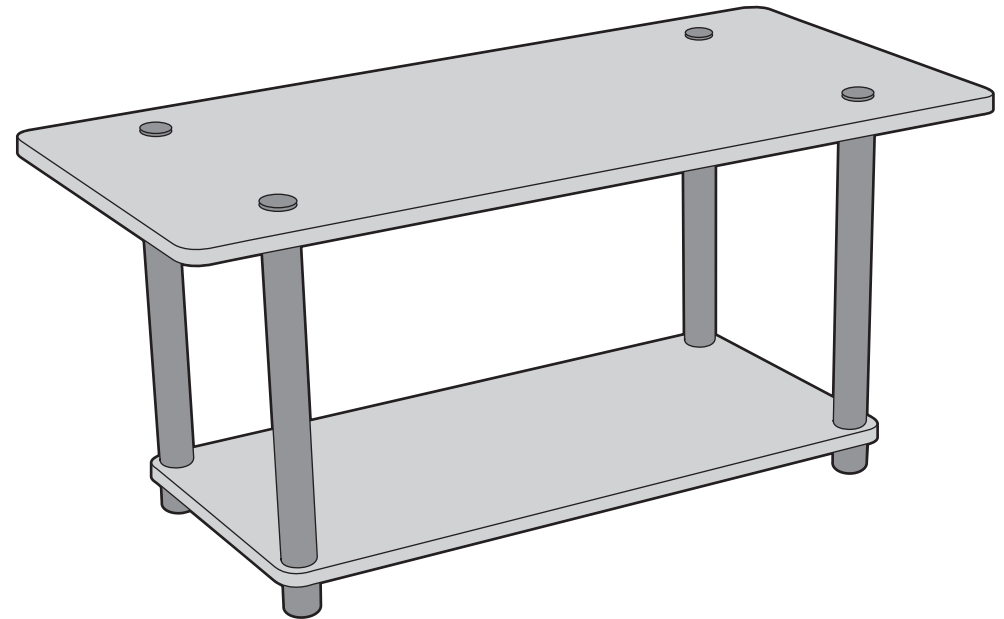

IMPORTANT

1. Read these instructions carefully and familiarise yourself with the procedure before assembling the unit.
2. Check that you have all the component parts following the list on the back cover and familiarise yourself with each part before proceeding.
3. Take all the fittings out of the plastic bag and separate them into their groups.
4. Ensure you have enough space to lay out all the parts before assembly.
5. To avoid scratching it is recommended that you assemble the unit on a soft level surface.

Fittings

Ⓐ 4 x Cap Screw



Assembly Instructions

Stage 1 – Fitting the Legs

1. Unscrew Cap Screws **A** from the Feet **D**.
See fig. 1.

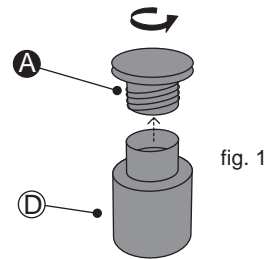

2. Use Legs **C** to fix the Feet **D** onto the Shelf **B**.
See fig. 2.

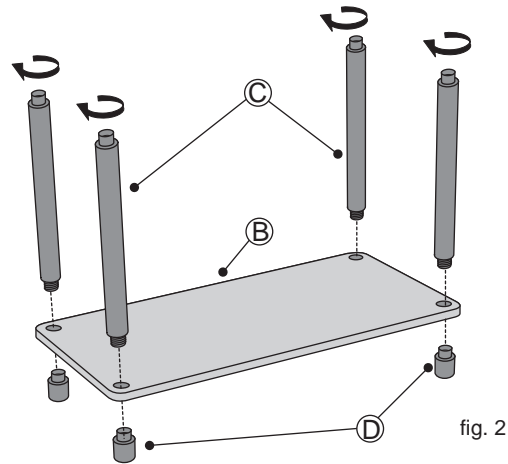

3. Use Cap Screws **A** to fix the Table Top **A** onto the unit.
See fig. 3.

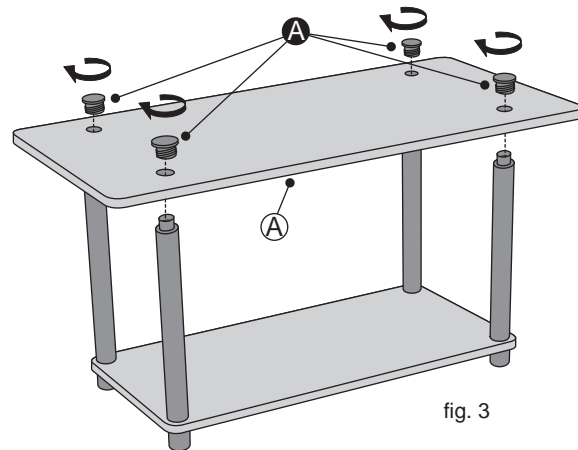

Assembly Instructions

Stage 2 – Finishing the Unit

1. Finally place the unit in the desired location.
See fig. 3.

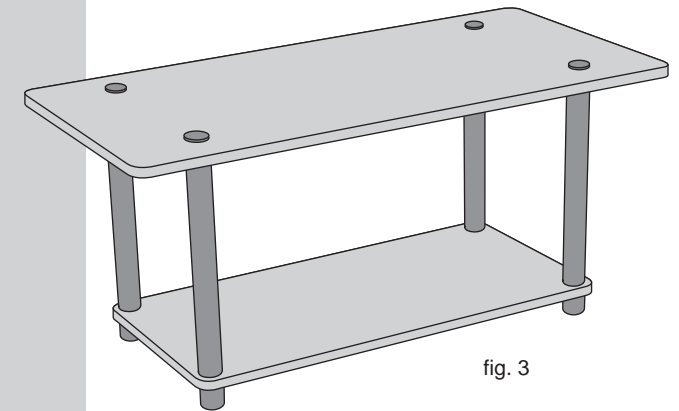

Care and Maintenance

Safety

To avoid any risk of suffocation to animals or children dispose of the plastic bags immediately.

Cleaning

As with all surfaces clean with a damp cloth and mild detergent, do not use bleach or abrasive products.

Fitting

From time to time please ensure there are no loose screws on the product.