

JAMAL NEST OF TABLES

Assembly Instructions - Please keep for future reference

609/7079

609/7086

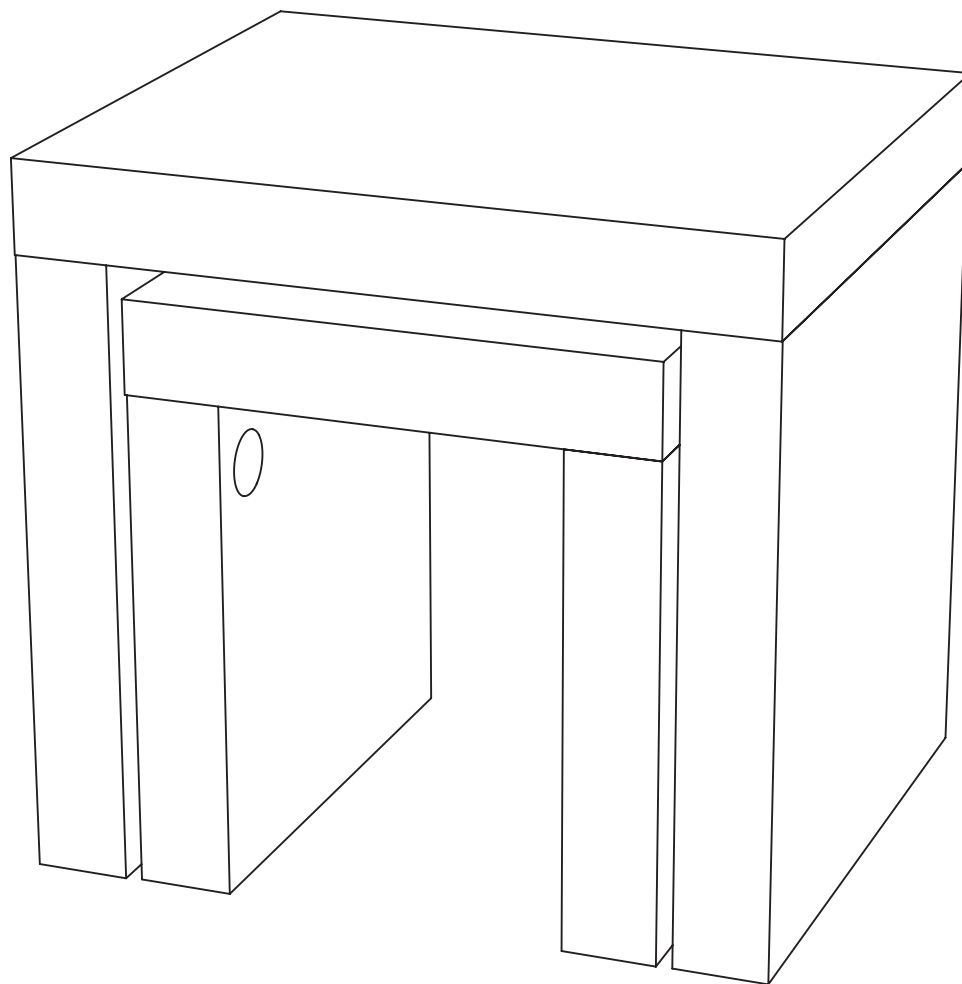

Dimensions

Width - 48cm

Depth - 40cm

Height - 46cm

Important - Please read these instructions fully before starting assembly

If you need help or have damaged or missing parts, call the **Customer Helpline: 08456 400800**



Safety and Care Advice

Important - Please read these instructions fully before starting assembly

- Check you have all the components and tools listed on pages 2 and 3.
- Remove all fittings from the plastic bags and separate them into their groups.
- Keep children and animals away from the work area, small parts could choke if swallowed.
- Make sure you have enough space to layout the parts before starting.

- Do not stand on the panels, this could cause damage.
- Assemble the unit as close to its final position (in the same room) as possible.
- Assemble on a soft level surface to avoid damaging the unit or your floor.
- Parts of the assembly will be easier with 2 people.



- We do not recommend the use of power drill/ drivers **for inserting screws**, as this could damage the unit. Only use hand screwdrivers.
- Dispose of all packaging carefully and responsibly.
- **Warning:** The unit weighs approximately 15.5kgs. **Please lift with care.**

Care and maintenance

- Only clean using a damp cloth and mild detergent, do not use bleach or abrasive cleaners.
- From time to time check that there are no loose screws on this unit.
- This product should not be discarded with household waste. Take to your local authority waste disposal centre.

Components - Panels

If you have damaged or missing components, call the **Customer Helpline:08456 400800**

Please check you have all the panels listed below

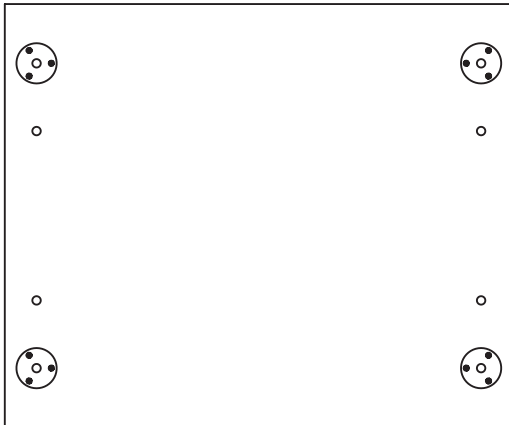

1 Top L (48 x 40cm)

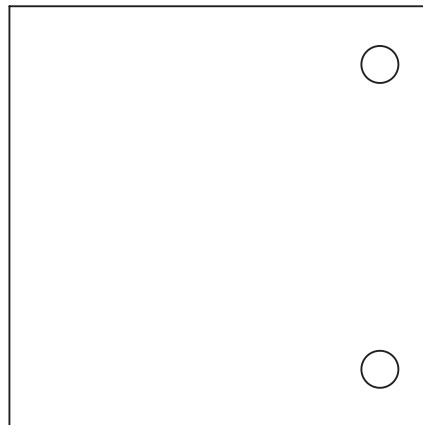

2 Side L x 2 (40 x 39.8cm)

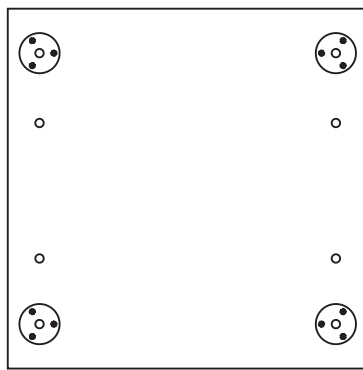

3 Top M (34 x 34cm)

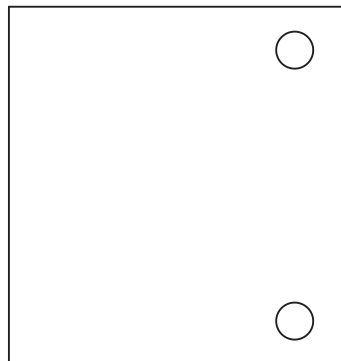









4 Side M x 2 (32x 33.8cm)

Components - Fittings

Please check you have all the fittings listed below

Note: The quantities below are the correct amount to complete the assembly. In some cases more fittings may be supplied than are required.

<p>A </p> <p>Threaded bolt x 8</p>	<p>B </p> <p>Dowel x 8</p>	<p>C </p> <p>Spacer x 8</p>
<p>D </p> <p>Washer x 8</p>	<p>E </p> <p>Spring washer x8</p>	<p>F </p> <p>Screw nut x 8</p>
<p>G </p> <p>Wrench x 1</p>	<p>H </p> <p>Cover cap x 8</p>	<p>I </p> <p>Foot pad x 8</p>

Tools required



Assembly Instructions

Step 1

Fitting bolts and dowels

a: Screw in Threaded bolt **A** onto Top **1** .

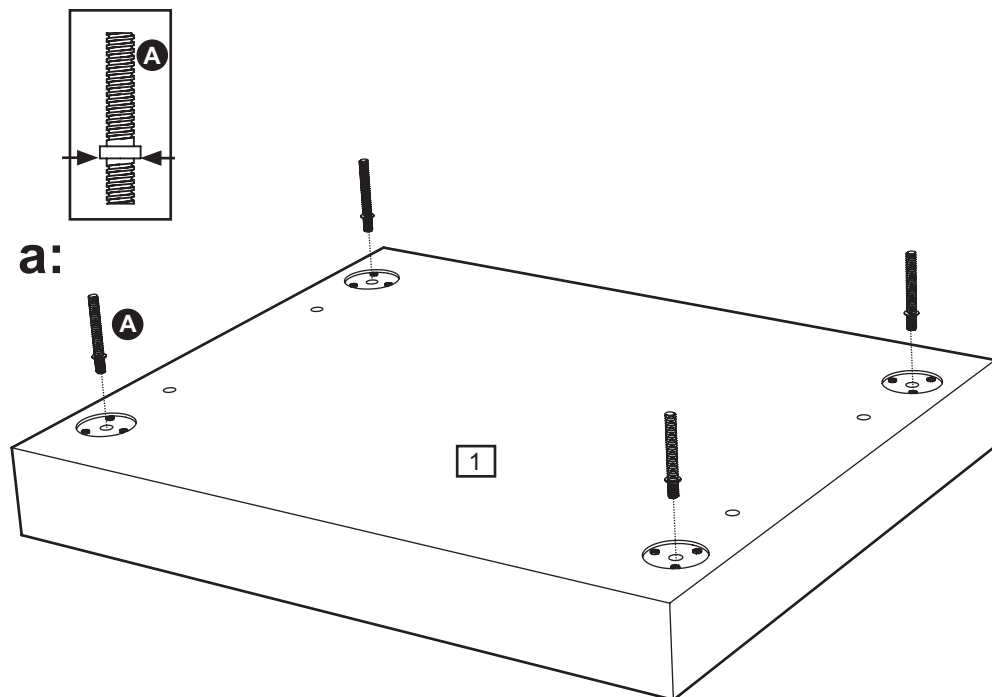

b: Insert Dowels **B** into Sides **2** .

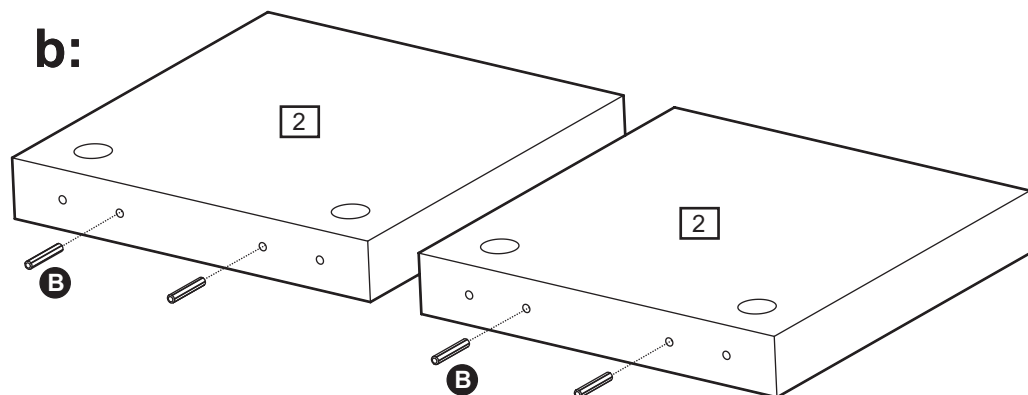

Assembly Instructions

Step 2

Fitting the side panel

a: Use Spacers **C**, Washers **D**, Spring washers **E**, Screw nuts **F** and Wrench **G** to fix Sides **2** onto Top **1**.

Note: A Long-nose pliers is required to fully tighten the Screw nuts **F**.

b: Use Cover caps **H** to cover the holes on Sides, Stick Foot pad **I** onto the unit.

Note: Repeat Step 1 and Step 2 to assemble the small table using Top **3** and Side **4**.

Assembly is complete.

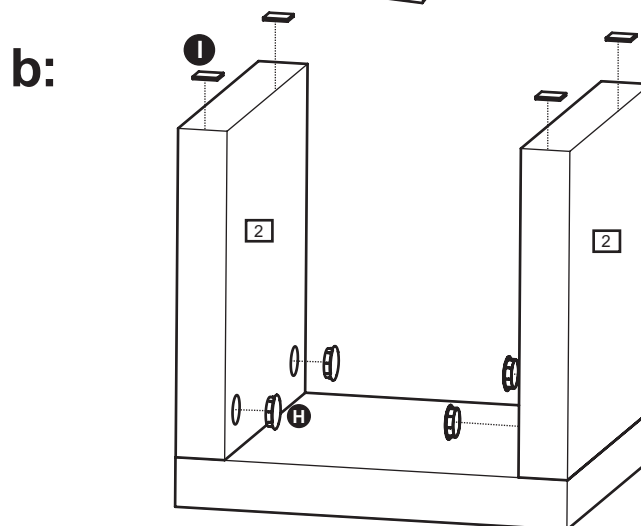
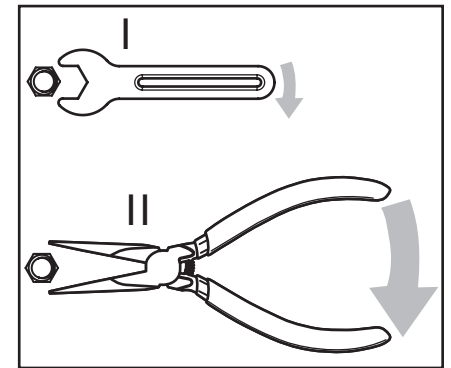
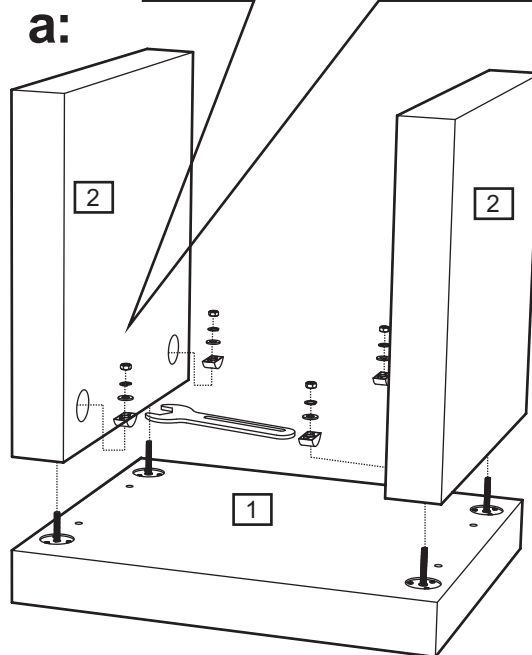
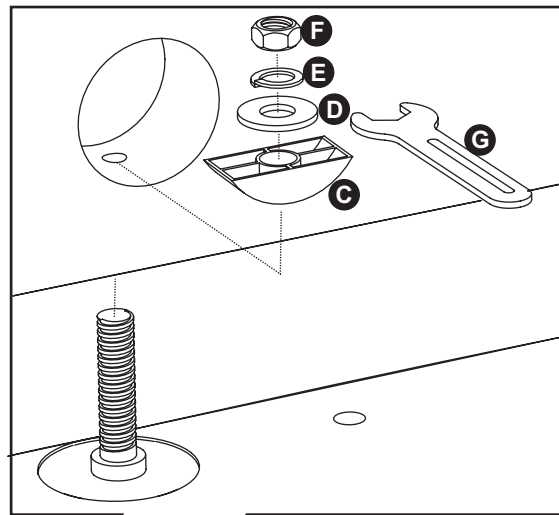

If you need help or have damaged or missing parts, call the **Customer Helpline : 08456 400800**