

Components

Ⓐ 1 x Top Panel

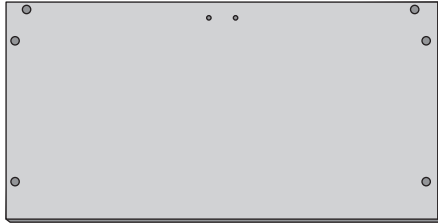

Ⓓ 1 x Bottom Panel



Ⓑ 1 x Shelf



Ⓔ 2 x Door

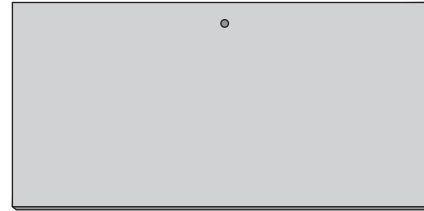

Ⓒ 2 x Side Panel

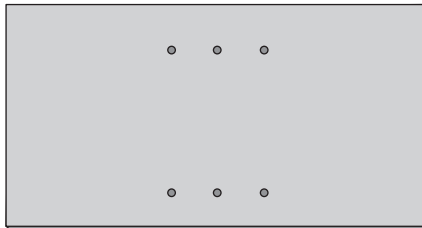

Ⓕ 2 x Back Panel

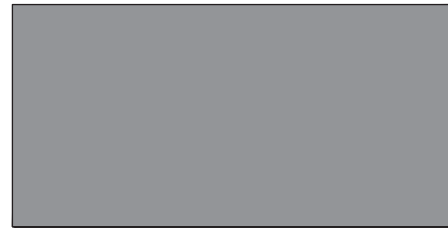

Ⓖ 8 x Plastic Plug



Ⓘ 4 x Support Cover



Ⓚ 2 x Metal Plate



Ⓗ 4 x Shelf Support



Ⓝ 2 x Handle



Ⓛ 1 x Door Stopper



Fittings

Ⓐ 8 x Screw



Ⓑ 16 x Nail



Ⓒ 4 x Hinge



Ⓓ 2 x Screw



Ⓔ 2 x Screw



Ⓕ 2 x Screw



Ⓖ 1 x Nail Guide



8-05

Maine Basic Modular 2 Doors

Simple Assembly Instructions - Please keep for future reference

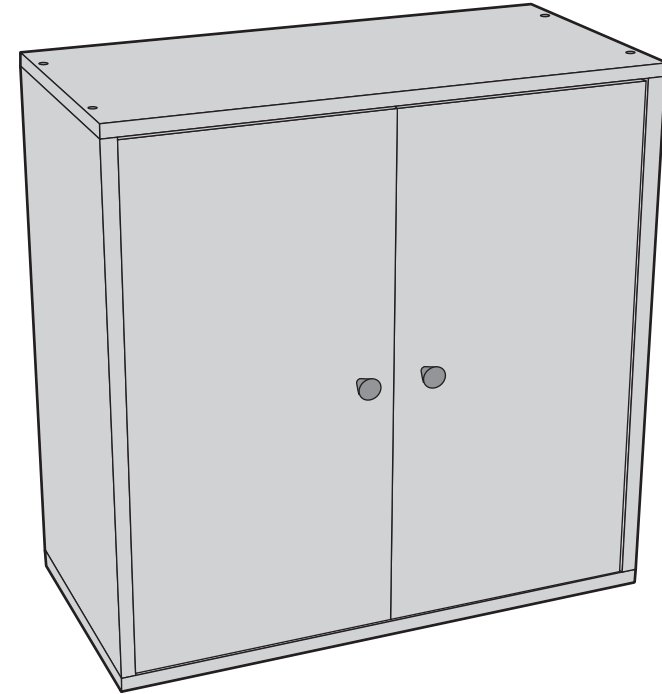

IMPORTANT

1. Read these instructions carefully and familiarise yourself with the procedure before assembling the unit.
2. Check that you have all the component parts following the list on the back cover and familiarise yourself with each part before proceeding.
3. Take all the fittings out of the plastic bag and separate them into their groups.
4. Ensure you have enough space to lay out all the parts before assembly.
5. To avoid scratching it is recommended that you assemble the unit on a soft level surface.

Assembly Instructions

Stage 1 – Fitting the Side Panel

NOTE: It would be useful to ask someone to help you at this stage.

1. Use Screw **A** to fix the Side Panels **C** onto the Bottom Panel **D**.
See fig. 1.

NOTE: Ensure the shelf fixing holes on Side Panels **C** face inwards.

2. Use Screws **E** to fix the Metal Plates **K** onto the Doors **E**.
See fig. 2.

3. Use Screws **F** to fix the Handles **J** onto the Doors.
See fig. 2.

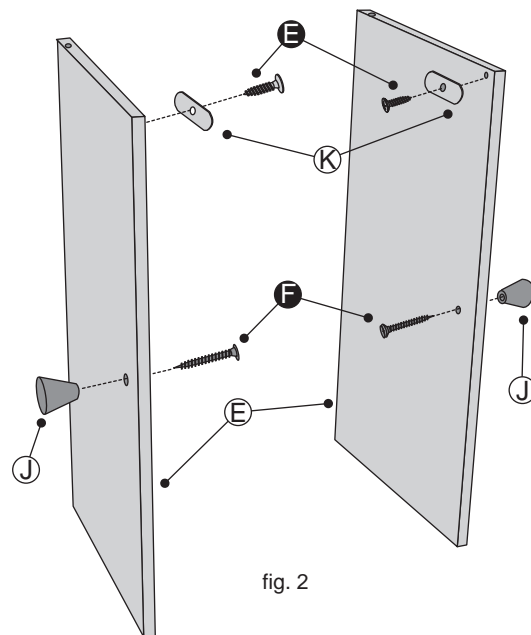
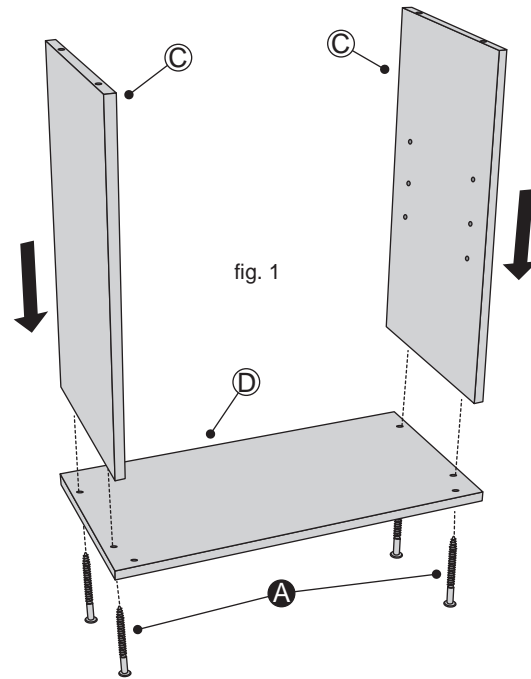

Assembly Instructions

Stage 2 – Fitting the Doors

NOTE: It would be useful to ask someone to help you at this stage.

1. Insert the Hinges **C** into the Doors **E**.
See fig. 3.
2. Carefully locate the Doors onto the unit, aligning the Hinges with the corresponding holes.
See fig. 3.

3. Use Screws **A** to fix the Top Panel **A** onto the unit.
See fig. 4.

NOTE: Ensure the Hinges are aligned with the corresponding holes.

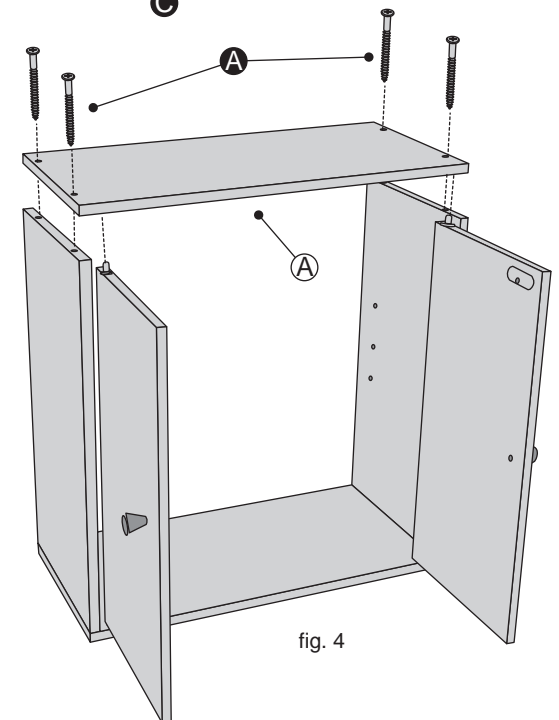
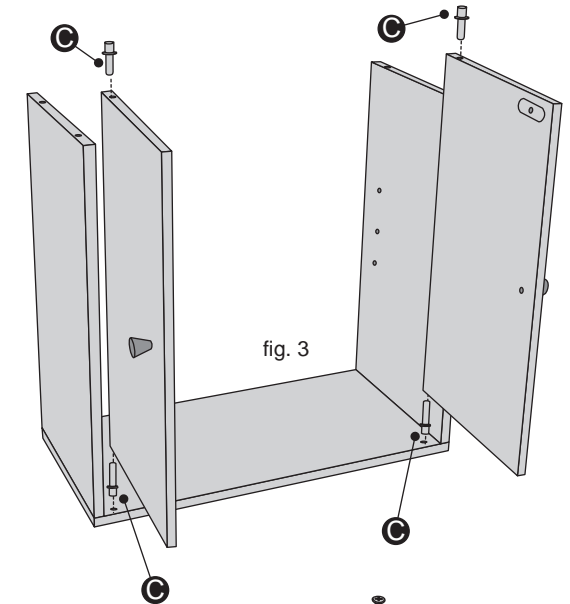

Assembly Instructions

Stage 3 – Fitting the Back Panel

NOTE: It would be useful to ask someone to help you at this stage.

1. Carefully lay the unit flat.
See fig. 5.
2. Use Nails **B** to fix the Back Panels **F** onto the unit.
See fig. 5.

NOTE: Use Nail Guide **G** to keep a constant distance from the edge.

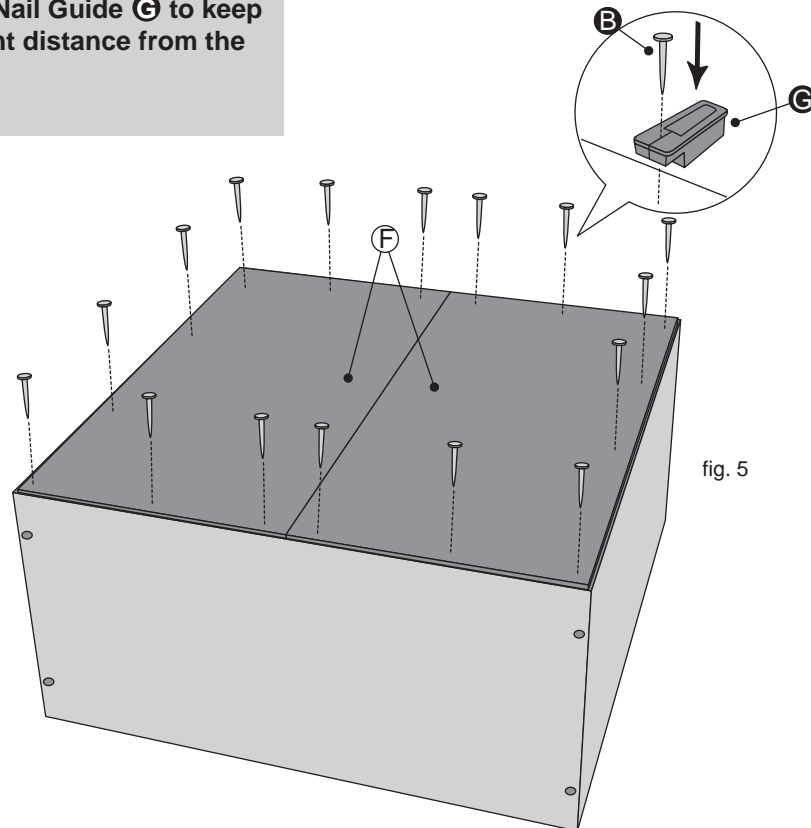

Assembly Instructions

Stage 4 – Fitting the Shelf

1. Insert Shelf Supports **H** into the holes in the unit. Then use Support Covers **I** to cover the Shelf Supports.
See fig. 6.

NOTE: Adjust the shelf supports to the desired height.

2. Slide Shelf **B** into the unit.
See fig. 7.

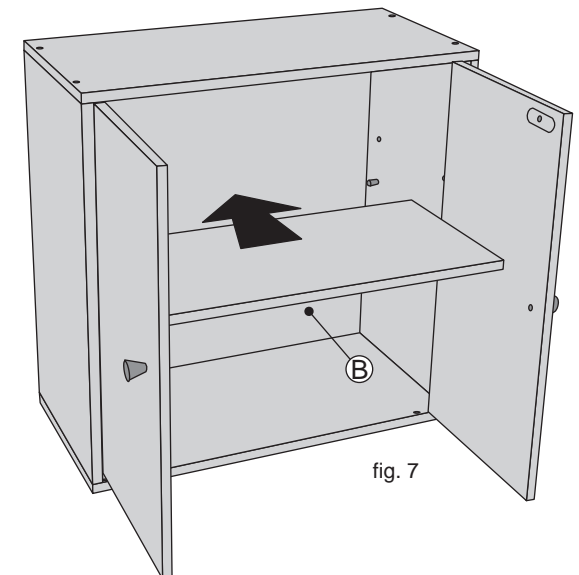
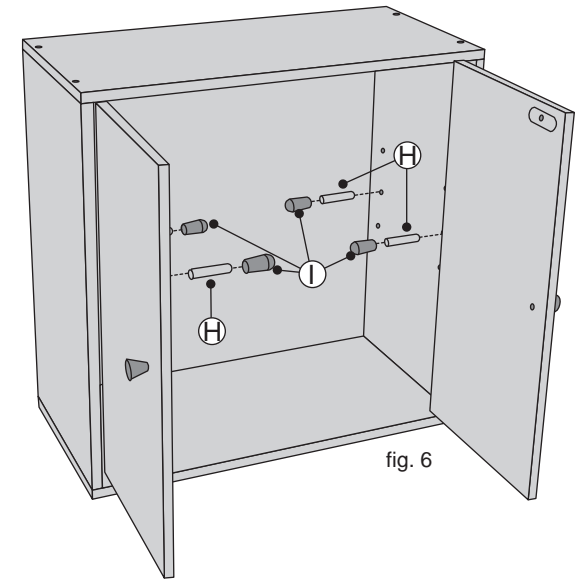

Assembly Instructions

Stage 5 – Fitting the Door Stopper

NOTE: It would be useful to ask someone to help you at this stage.

1. Use Screw **D** to fix the Door Stopper **L** onto the unit.
See fig. 8.

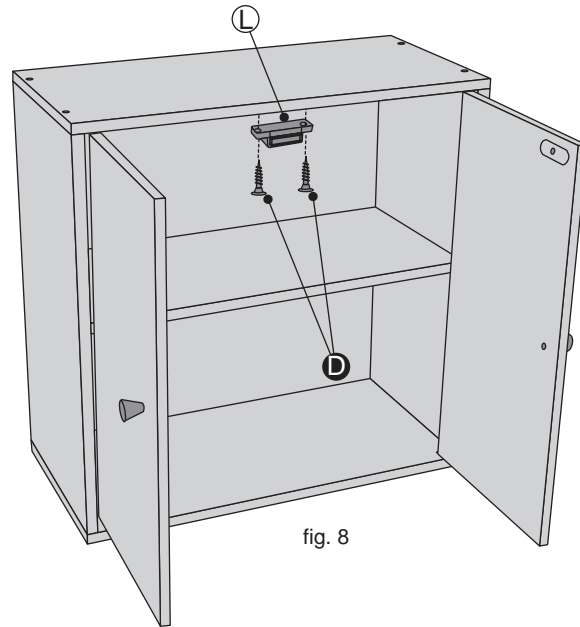

2. Use Plastic Plugs **G** to cover the Screw Heads.
See fig. 9.

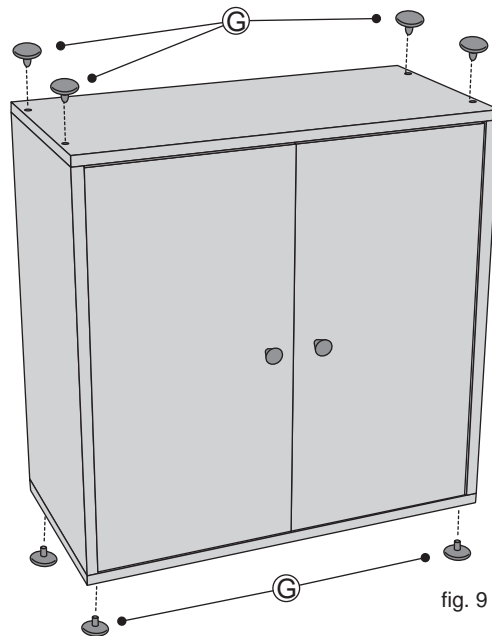

Assembly Instructions

Stage 6 – Finishing the Unit

NOTE: It would be useful to ask someone to help you at this stage.

1. Carefully place the unit in the desired location.
See fig. 10.

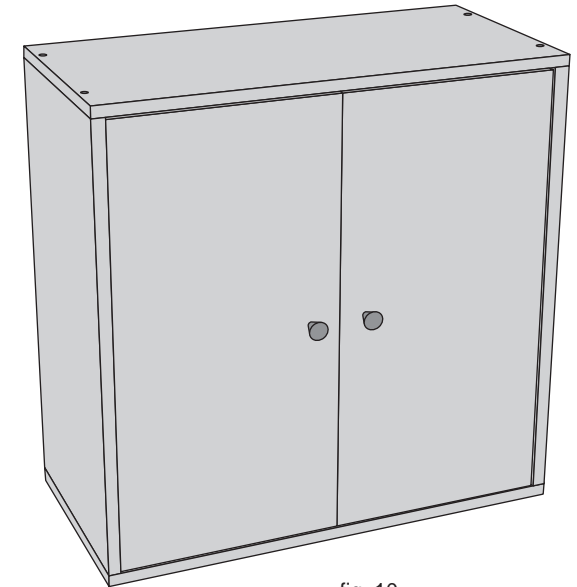

Care and Maintenance

Safety

To avoid any risk of suffocation to animals or children dispose of the plastic bags immediately.

Cleaning

As with all surfaces clean with a damp cloth and mild detergent, do not use bleach or abrasive products.

Fitting

From time to time please ensure there are no loose screws on the product.

Maine Basic Modular 2 Doors

Assembly Instructions - Please keep for future reference

609/0045

609/2579

609/2603

609/2634

609/2665

610/8913

875/4372

875/4389

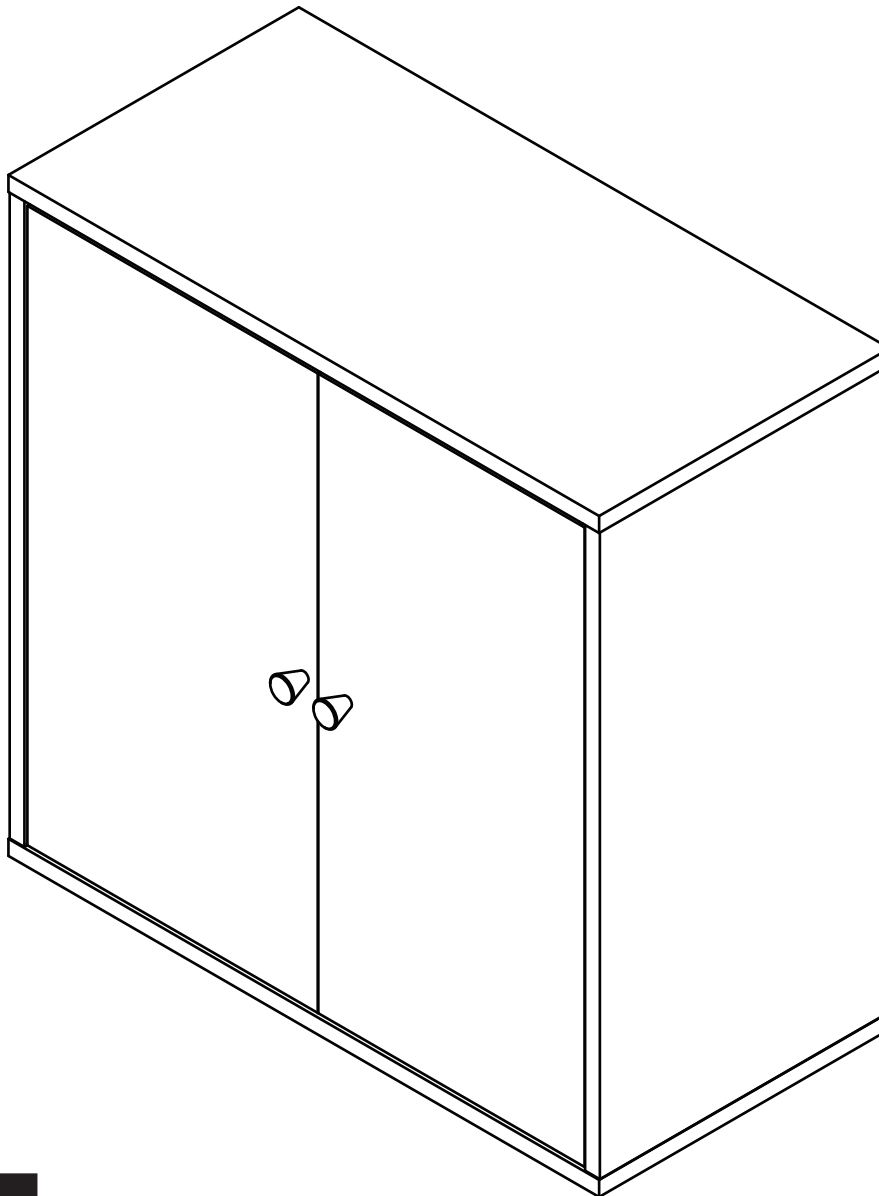

Dimensions

Width - 60.1cm

Depth - 32.3cm

Height - 60cm

Important - Please read these instructions fully before starting assembly

If you need help or have damaged or missing parts, call the **Customer Helpline: 08456 400800**



Safety and Care Advice

Important – Please read these instructions fully before starting assembly

- Check you have all the components and tools listed on pages 2 and 3.
- Remove all fittings from the plastic bags and separate them into their groups.
- Keep children and animals away from the work area, small parts could choke if swallowed.
- Make sure you have enough space to layout the parts before starting.

- Do not stand on the product, this could cause damage.
- Assemble the item as close to its final position (in the same room) as possible.
- Assemble on a soft level surface to avoid damaging the unit or your floor.
- Parts of the assembly will be easier with 2 people.



• We do not recommend the use of power drill/drivers **for inserting screws**, as this could damage the unit. Only use hand screwdrivers.

- Dispose of all packaging carefully and responsibly.

• **Note:** Only apply the glue once you are sure of the assembly.

Glue safety - Take care when using glue, please follow the advice below

Skin contact: Remove contamination by washing with soap and water. This procedure should also be followed prior to eating and drinking.

Eye contact: Rinse immediately with clean water for 15 minutes and seek medical advice.

If swallowed: Seek medical advice immediately.

Care and maintenance

• Only clean using a damp cloth and mild detergent, do not use bleach or abrasive cleaners.

• From time to time check that there are no loose screws on this unit.

• This product should not be discarded with household waste. Take to your local authority waste disposal centre.

Note: if required the next page can be cut out and used as reference throughout the assembly. Keep this page with these instructions for future reference.

Components - Panels

Please check you have all the panels listed below

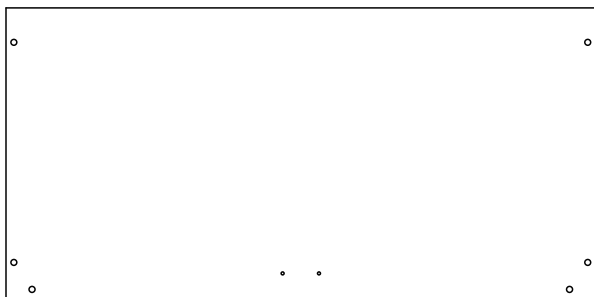

1 Top Panel (600 x 295mm)



2 Bottom Panel (600 x 295mm)

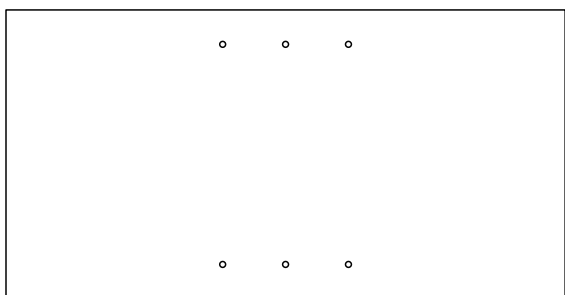

3 Side Panel x 2 (569 x 294mm)

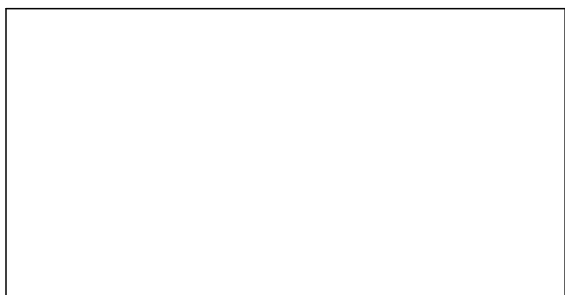

4 Shelf Panel (569 x 275mm)

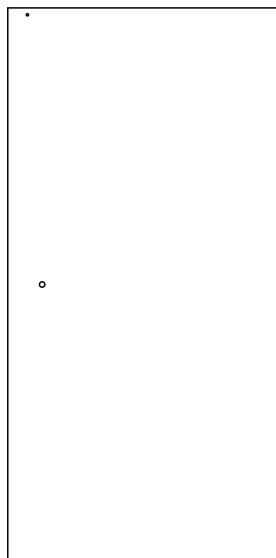

5 Left Door Panel (280 x 563mm)

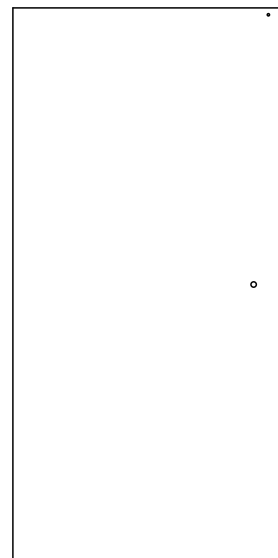

6 Right Door Panel (280 x 563mm)

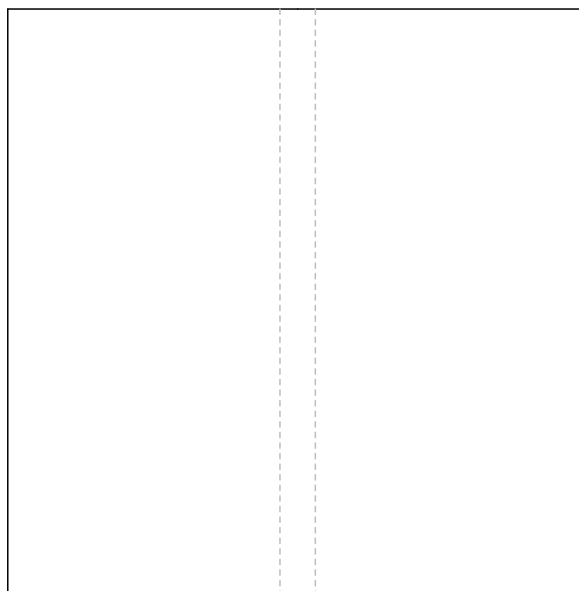

7 Back Panel (590 x 596mm)











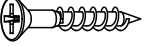

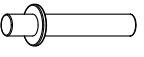
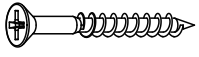
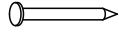
Components - Fittings

If you have damaged or missing components, call the **Customer Helpline: 08456 400800**

Please check you have all the fittings listed below

Note: The quantities below are the correct amount to complete the assembly. in some cases more fittings may be supplied than are required.

A  25mm Screw x 2	B  Handle x 2	C  Metal Plate x 2
D  Door Hinge x 4	E  40mm Screw x 8	F  Nail x 16
G  Nail Guide x 1	H  Door Stopper x 1	I  Shelf Support x 4
J  Support Cover x 4	K  Covering Sticker x 4	L  10mm Screw x 2
M  14mm Screw x 2		

Tools required

 Phillips screwdriver
(medium & large)

 Flatblade screwdriver
(medium)

 Bradawl
(or sharp point)

 Small
hammer

 Ruler/tape
measure

 Eye protection
(when using a
hammer or glue)

Ruler - Use this ruler to help correctly identify the screws

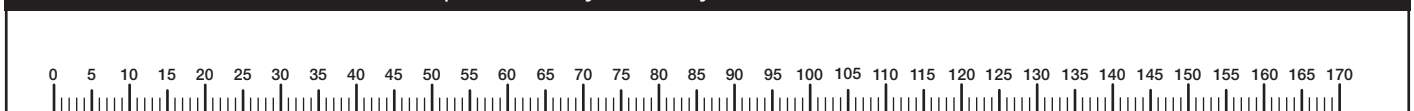

Assembly Instructions

Step 1

Attaching side panels

a: Use Screws **E** to fix the Bottom Panel **2** onto the Side Panels **3**.

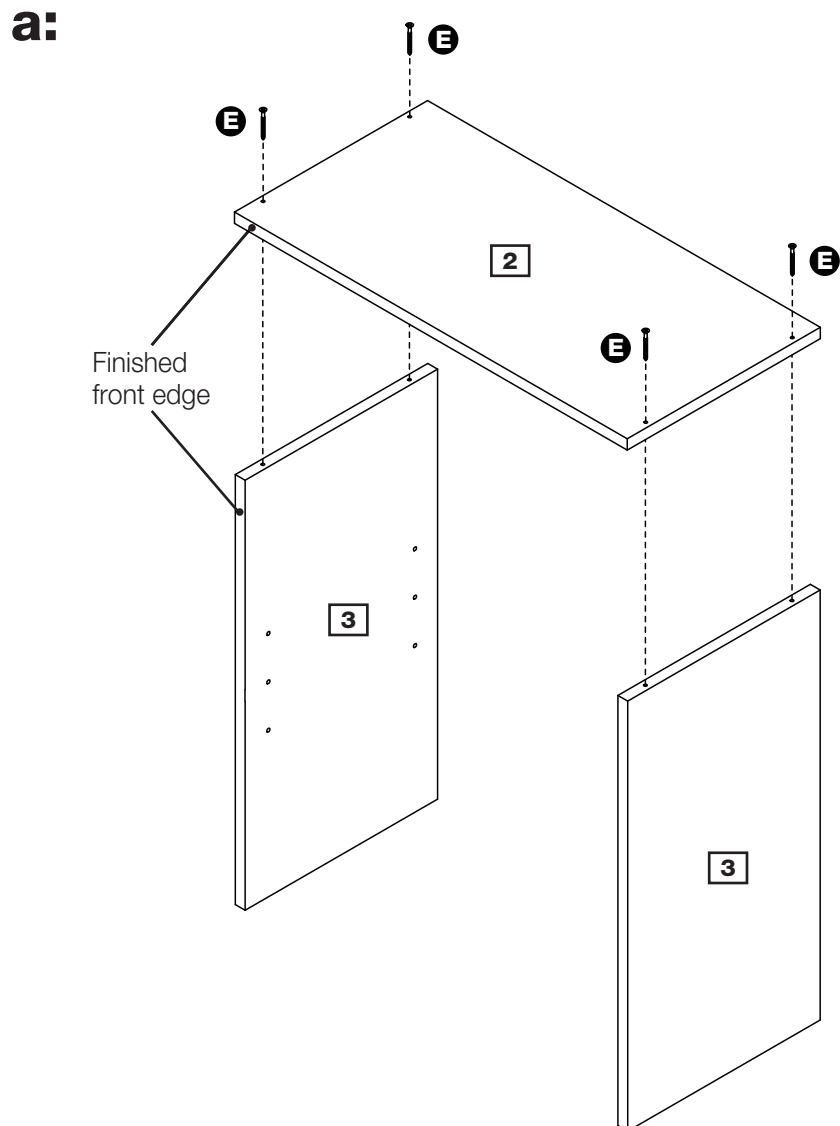

Step 2

Attaching door panels

a: Use Screw **L** to fix the Metal Plate **C** onto the Left Door Panel **5**.

Use Screw **A** to fix the Handle **B** onto the Left Door Panel **5**.

Insert the Door Hinge **D** into the Left Door Panel **5**.

Repeat **a** with remaining Right Door Panel **6**.

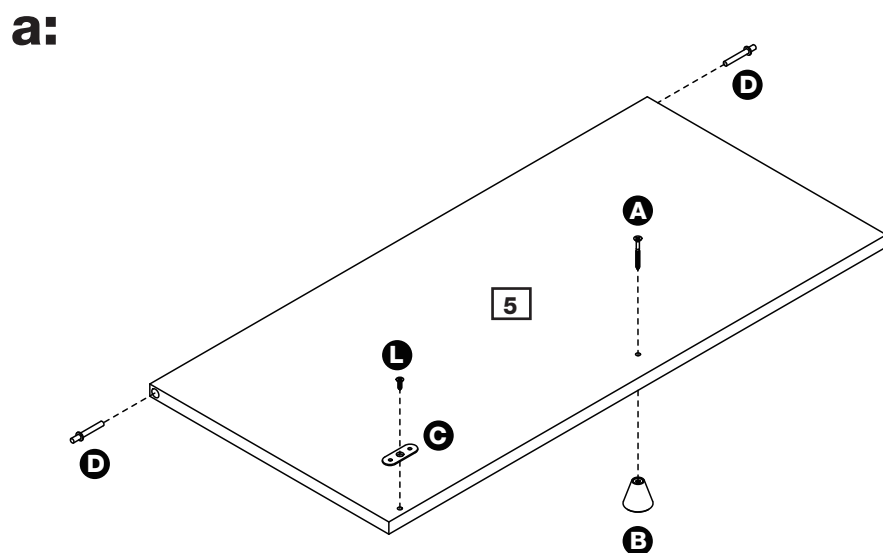

Assembly Instructions

Step 2 - continued

b: Carefully locate the Left Door Panel **5** and Right Door Panel **6** onto the unit aligning the Door Hinges with the corresponding holes.

Use Screws **E** to fix the Top Panel **1** onto the unit.

Note: Ensure the Door Hinges are aligned with the corresponding holes.

b:

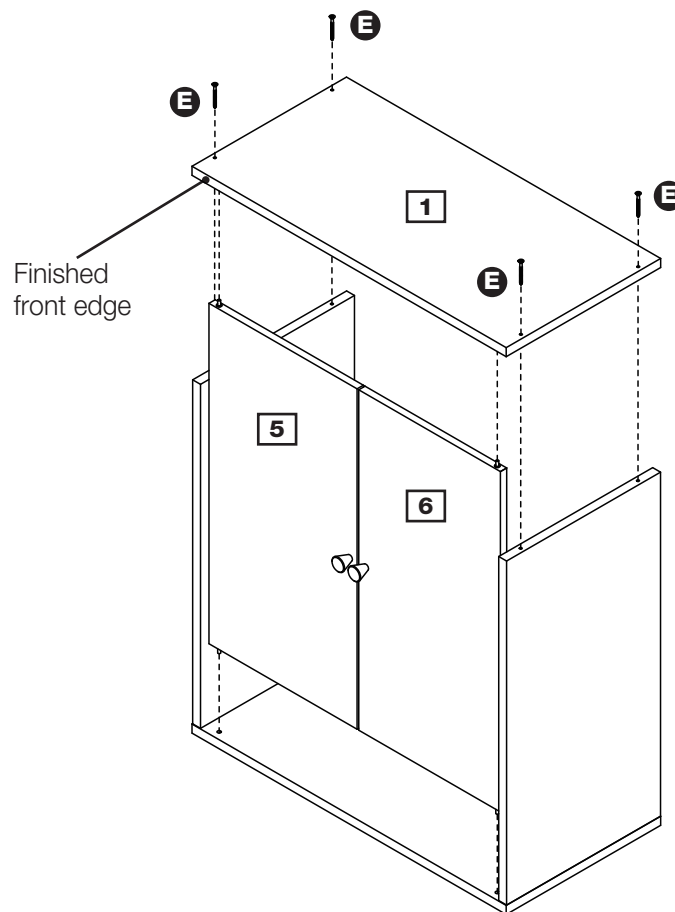

Step 3

Fixing back panel

a: Use Nails **F** to fix the Back Panel **7** onto the unit.

Note: Use Nail Guide **G** to keep a constant distance from the edge.

Important:
The cabinet **MUST** be 'square' when the back is attached.

a:

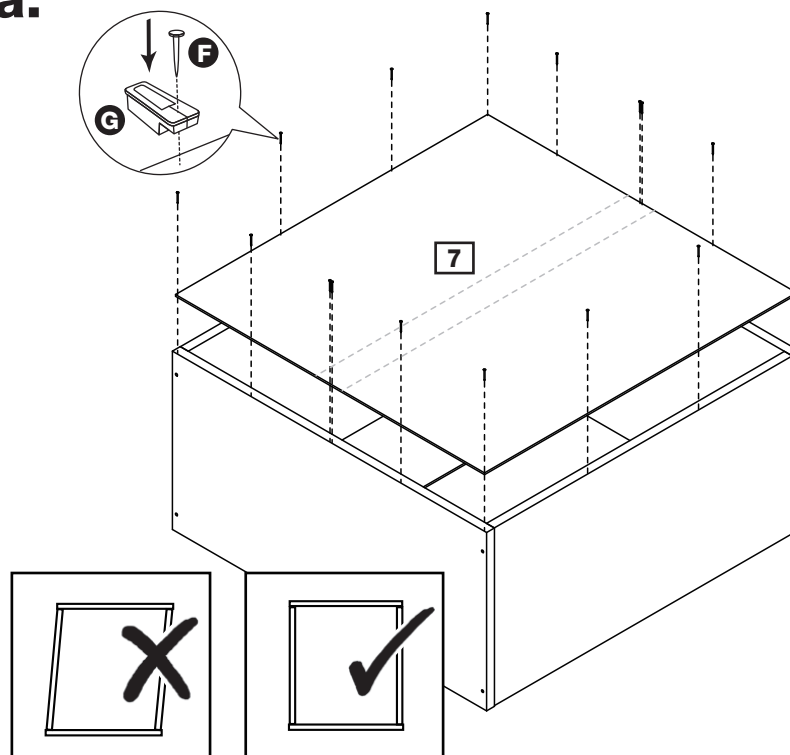

Assembly Instructions

Step 4

Attaching door stopper

a: Use Screws **M** to fix the Door Stopper **H** onto the unit.

a:

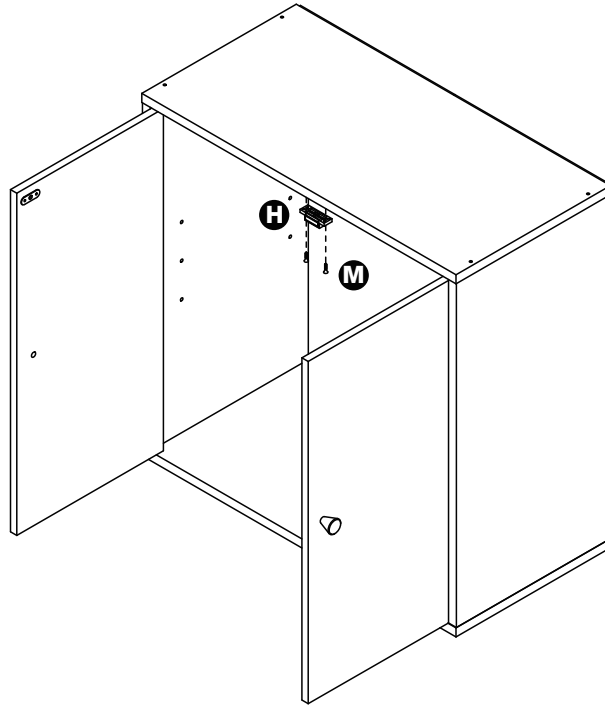

Step 5

Attaching shelf panel

a: Slide Support Covers **J** onto Shelf Supports **I**.

a:

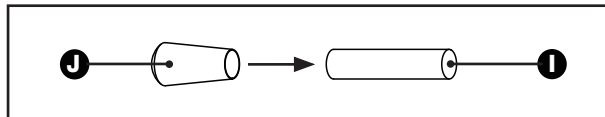

Insert Shelf Supports **I** (Support Covers **J** are included) into the unit. Ensure they are well fitted before inserting the Shelves.

Note: Set the shelf supports to the desired height.

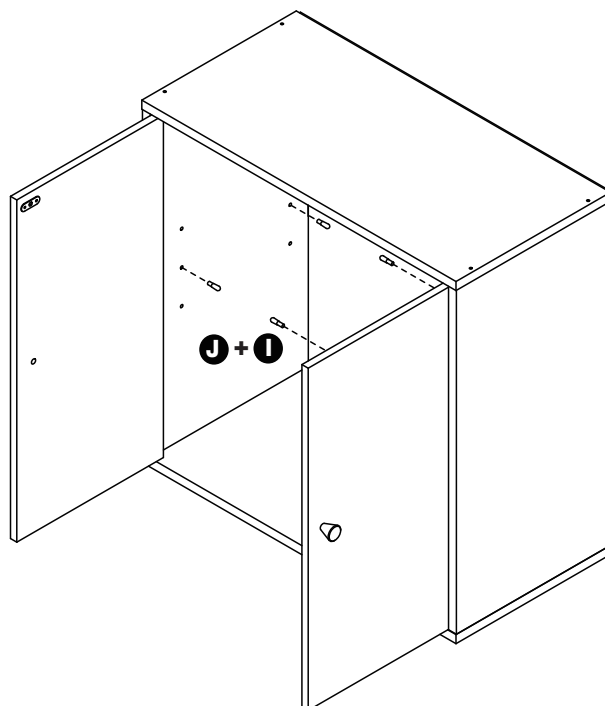

Assembly Instructions

Step 5 - continued

b: Slide the Shelf Panel **4** into the unit.

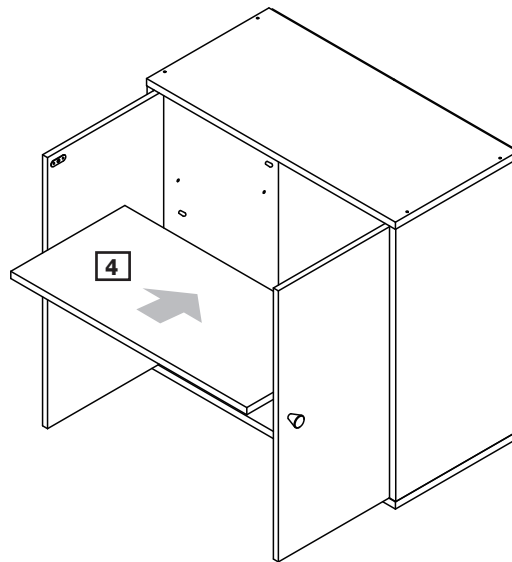

c: Use Covering Sticker **K** to cover the screw heads.

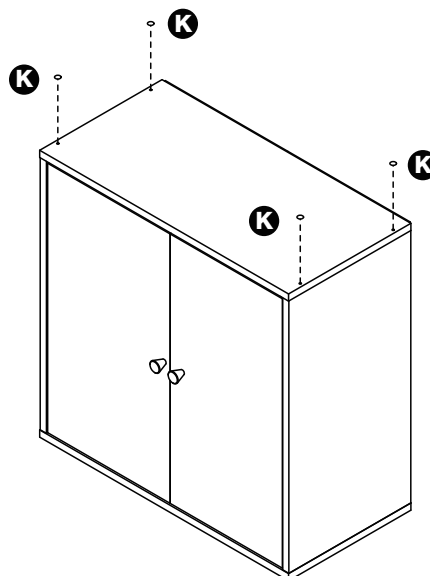

Step 6

Finishing the unit

Note: It would be useful to ask someone to help you at the stage.

With help, place the unit in the intended position.

The assembly is now complete.

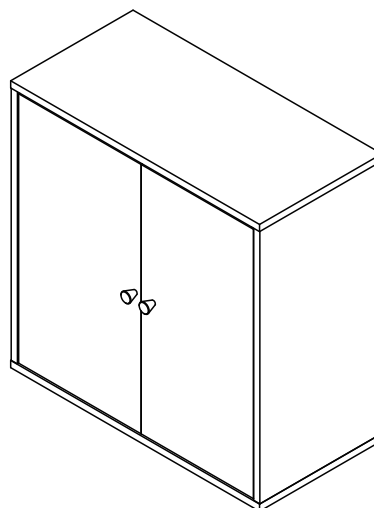

If you need help or have damaged or missing parts, call the
Customer Helpline: 08456 400800

Boston Basic Modular 2 Door

Assembly Instructions - Please keep for future reference

609/0045

609/2603

610/8913

413/6293

402/9568

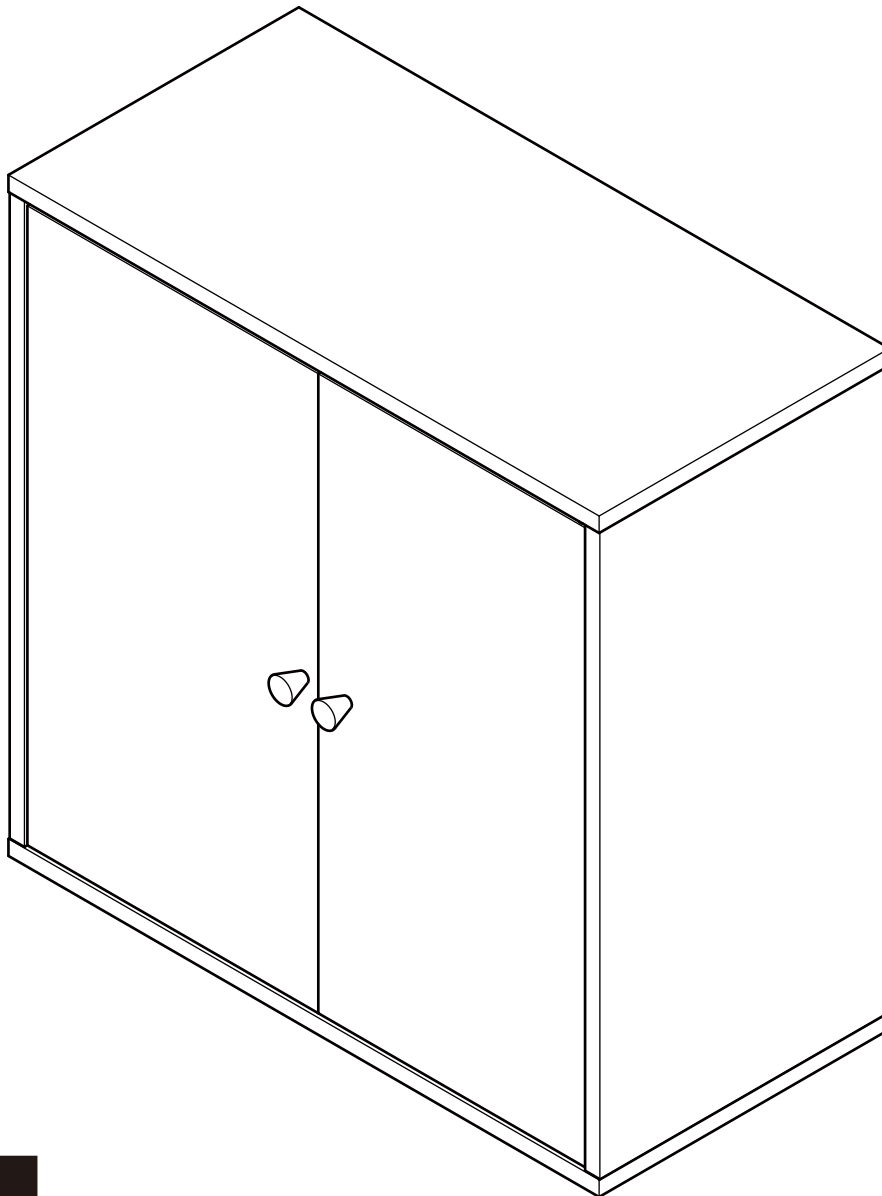

Dimensions

Width - 60cm

Depth - 30cm

Height - 60cm

Important - Please read these instructions fully before starting assembly

If you need help or have damaged or missing parts, call the **Customer Helpline:**
Argos = 0345 6400800



Safety and Care Advice

Important – Please read these instructions fully before starting assembly

- Check you have all the components and tools listed on the following pages.
- Remove all fittings from the plastic bags and separate them into their groups.
- Keep children and animals away from the work area, small parts could choke if swallowed.
- Make sure you have enough space to layout the parts before starting.

- During assembly do not stand or put weight on the product, this could cause damage.
- Assemble the item as close to its final position (in the same room) as possible.
- Assemble on a soft level surface to avoid damaging the unit or your floor.
- Parts of the assembly will be easier with 2 people.

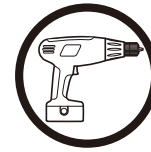

- To reduce the likelihood of damaging your product please ensure that your power drill is set on a low torque setting.

Care and maintenance

- Only clean using a damp cloth and mild detergent, do not use bleach or abrasive cleaners.
- From time to time check that there are no loose screws on this unit.
- This product should not be discarded with household waste. Take to your local authority waste disposal centre.

Handy Hints

- Assemble all parts and bolts loosely during assembly, only once the product is complete should you fully tighten the bolts
- Regularly check and ensure that all bolts and fittings are tightened properly.

Components - Panels

If you have damaged or missing components, call the
Customer Helpline: Argos = 0345 6400800

Please check you have all the panels listed below

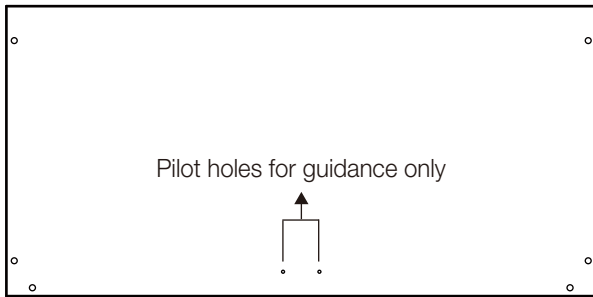

1 Top panel (60 x 29.5cm)



2 Bottom panel (60 x 29.5cm)

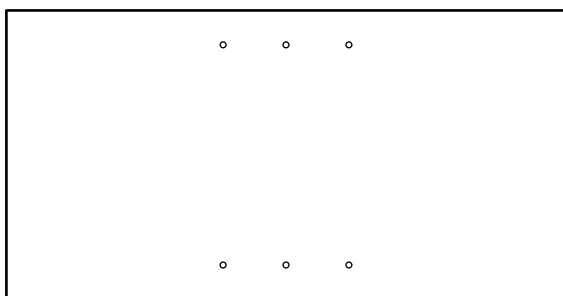

3 Side panel x 2 (56.9 x 29.4cm)



4 Shelf (56.9 x 27.5cm)

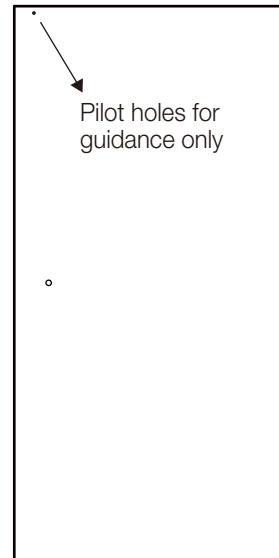

5 Left door panel
(28 x 56.3cm)

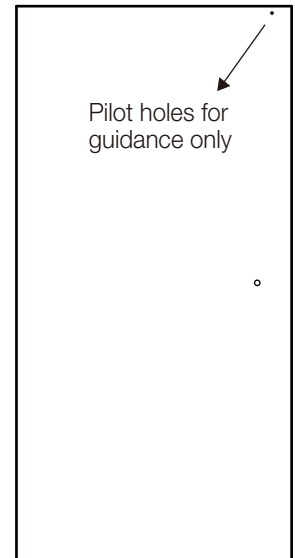

6 Right door panel
(28 x 56.3cm)

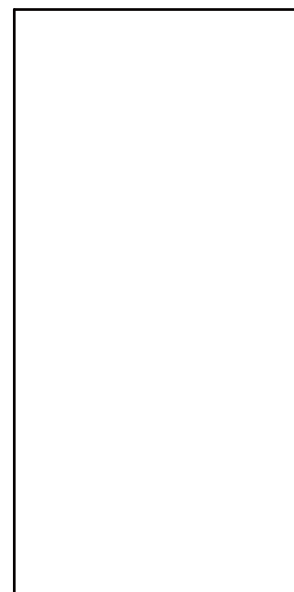









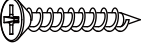

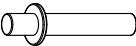
7 Back panel x 2
(29.5 x 59.6cm)

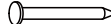
Components - Fittings

Please check you have all the fittings listed below

Note: The quantities below are the correct amount to complete the assembly. in some cases more fittings may be supplied than are required.

A  25mm Screw x 2	B  Handle x 2	C  Metal plate x 2
D  Door hinge x 4	E  40mm Screw x 8	F  Nail x 16
G  12mm Screw x 4	H  Door stopper x 1	I  Shelf support x 4
J  Support cover x 4	K  Screw cover x 4	

Tools required



Phillips screwdriver
(medium & large)

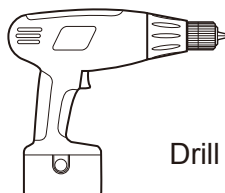

Drill



Small
hammer



7mm Suitable drill bit
(for use with wall plug)



Ruler/tape
measure

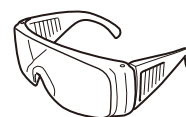

Eye protection
(when using a
hammer or glue)

Ruler - Use this ruler to help correctly identify the screws

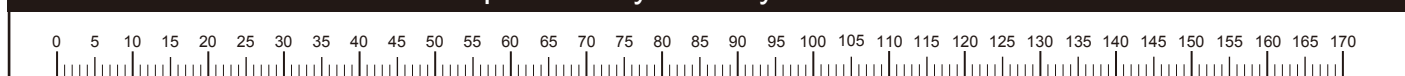

The screws length is measured from the head to the point (30mm screw shown).

Assembly Instructions

Step 1

Attaching side panels

Use Screws **E** to fix the Bottom panel **2** onto the Side panels **3**.

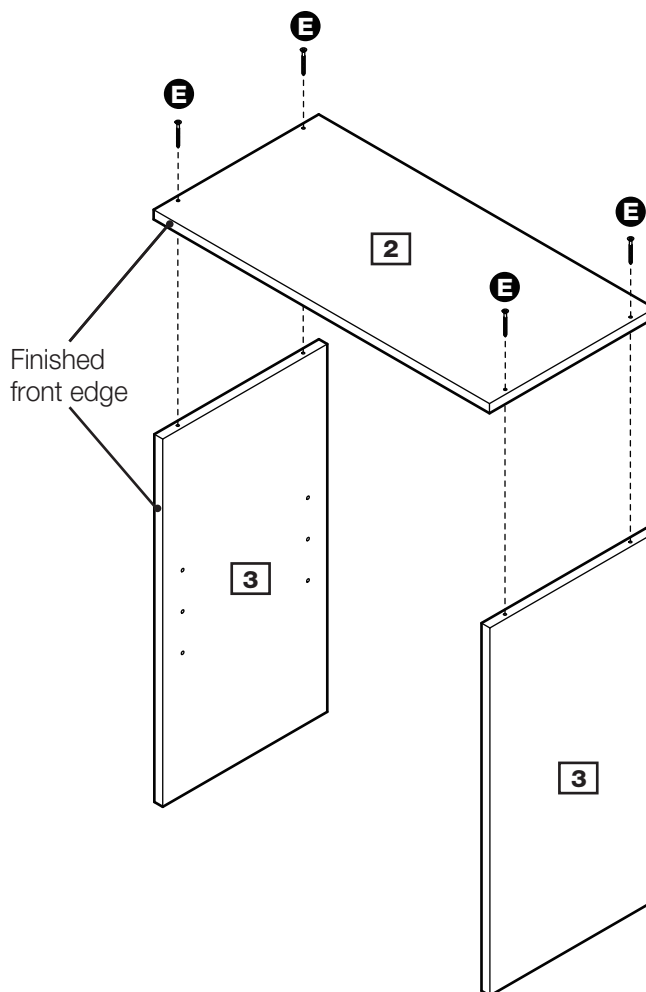

Step 2

Attaching door

a: Use Screws **G** to fix the Door stopper **H** onto the Top panel **1**.

Use Screw **G** to fix the Metal plate **C** onto the Left door panel **5**.

Insert the Door hinges **D** into the Left door panel **5**.

Repeat a with remaining Right door panel **6.**

a:

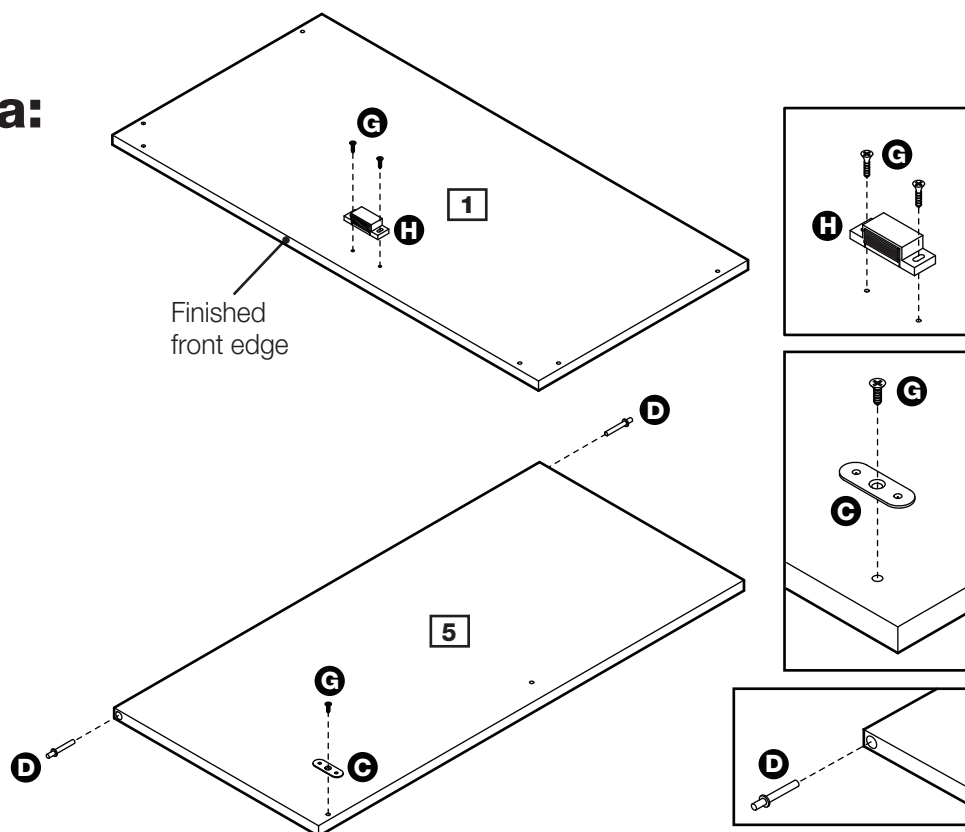

Continued on next page.

Assembly Instructions

Step 2 - continued

b: Carefully locate the Left door panel **5** and Right door panel **6** onto the unit aligning the Door hinges with the corresponding holes.

Use Screws **E** to fix the Top panel **1** onto the unit.

Note: Ensure the Door hinges are aligned with the corresponding holes.

b:

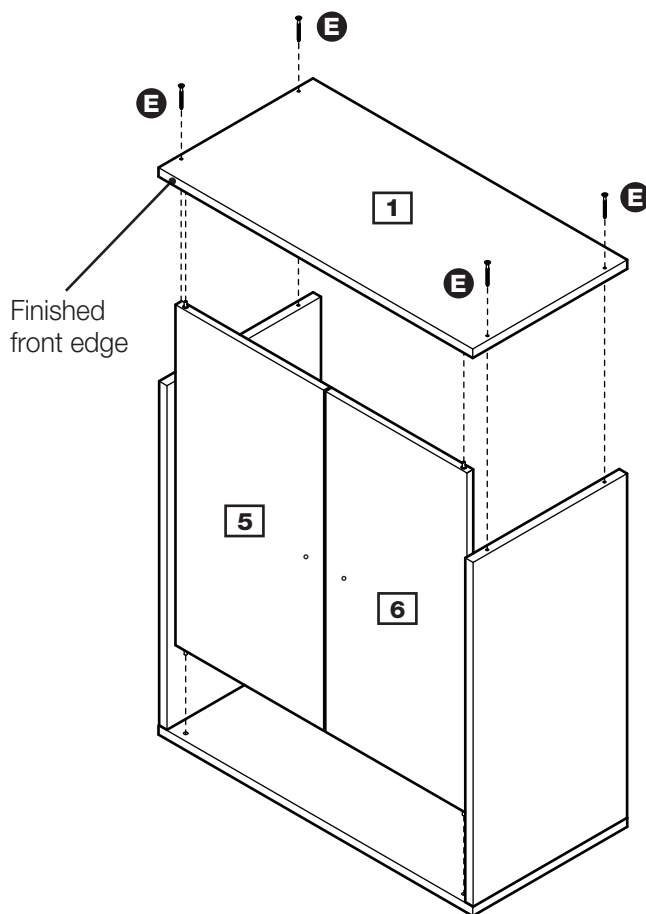

Step 3

Fixing back panel

Attach Back panels **7** onto the unit using Nails **F**.



Important:
The unit **MUST** be 'square' when back is attached.

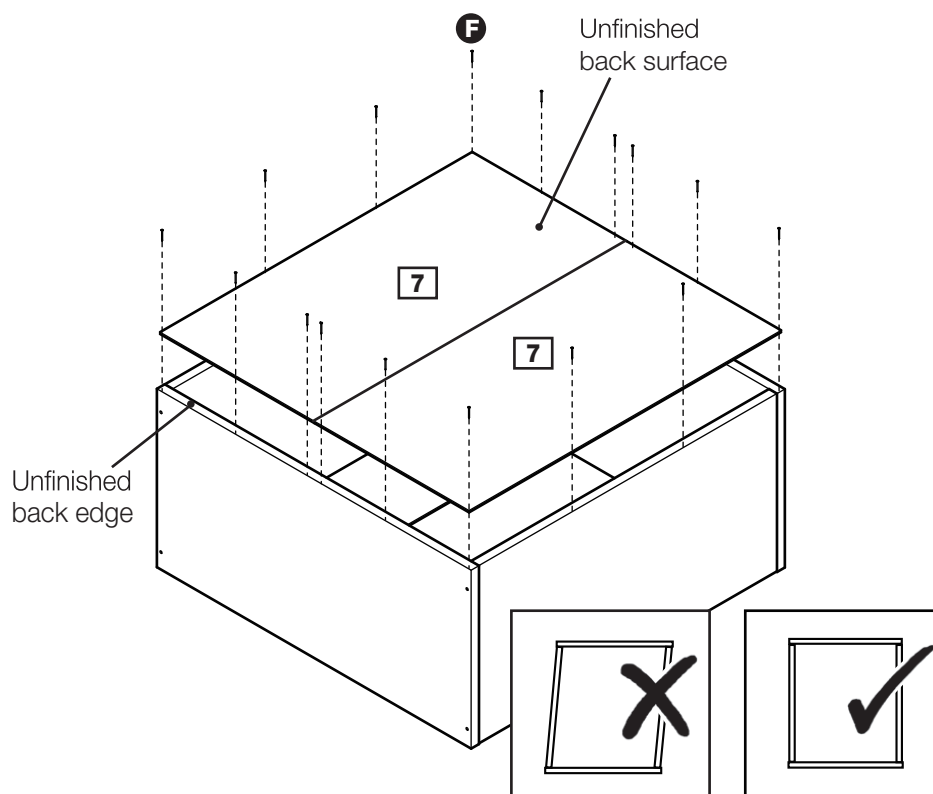

Assembly Instructions

Step 4

Attaching door handles

Use Screws **A** to fix the Handles **B** onto the Left door panel **5** and Right door panel **6**.

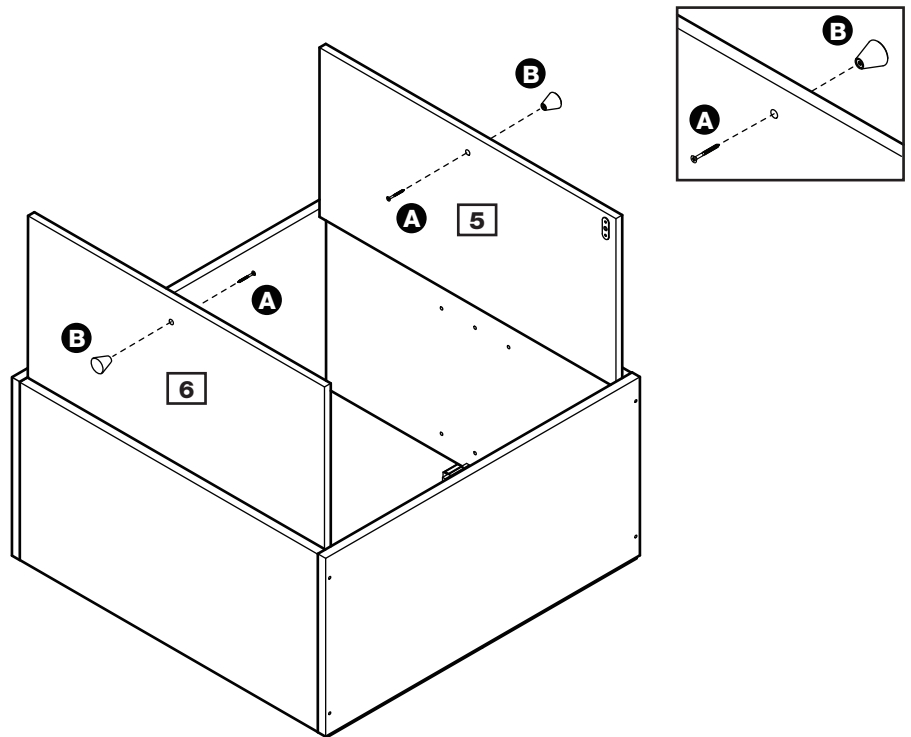

Step 5

Attaching shelf

a: Slide Support covers **J** onto Shelf supports **I**.

Insert Shelf supports **I** (Support covers **J** are included) into the unit. Ensure they are well fitted before inserting the shelf.

Note: Set the shelf supports to the desired height.

a:

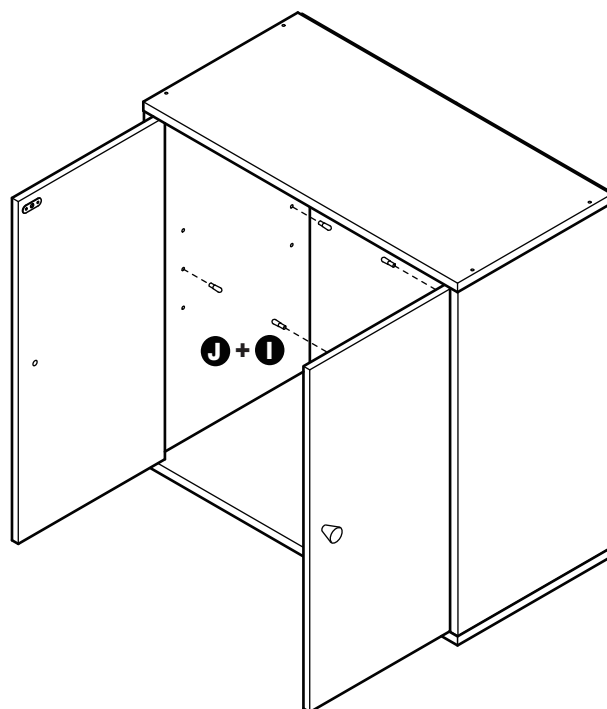
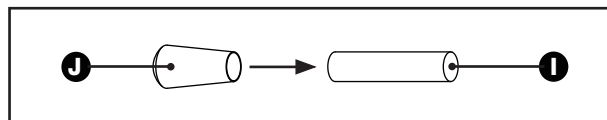

Continued on next page.

Assembly Instructions

Step 5 - continued

b: Slide the Shelf **4** into the unit.

b:

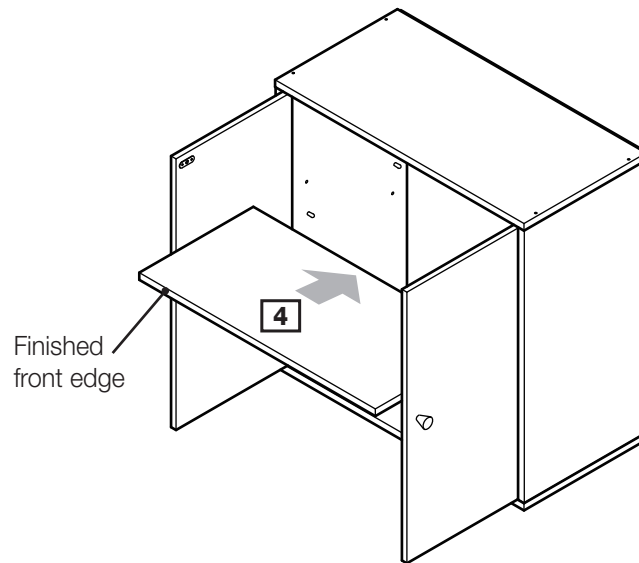

c: Use Screw covers **K** to cover the screw heads.

c:

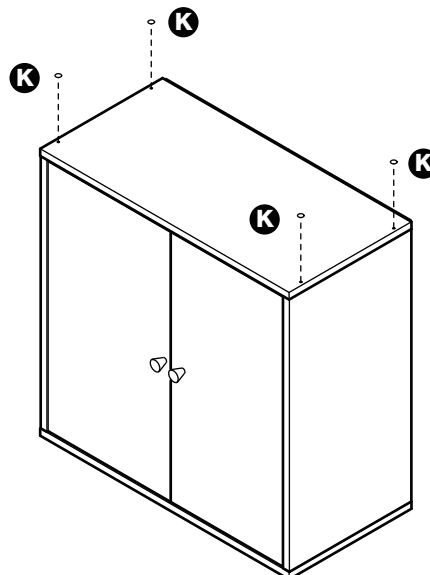

Step 6

Finishing the unit

Note: It would be useful to ask someone to help you at the stage.

With help, place the unit in the intended position.

Assembly is complete.

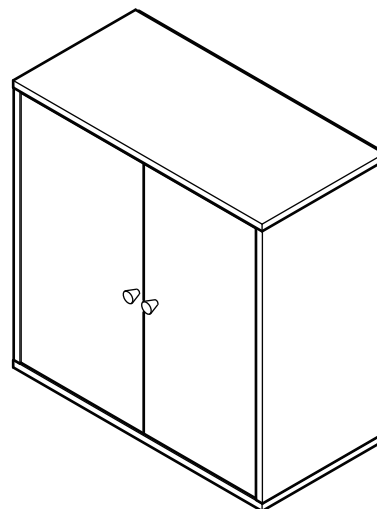

If you need help or have damaged or missing parts, call the **Customer Helpline:**
Argos = 0345 6400800