

Athina - 500 Drawer Unit

Assembly Instructions - Please keep for future reference

608/0804

608/0921

608/0866

608/0983



Dimensions

Width - 50cm

Depth - 59cm

Height - 89.5cm



**MADE IN
BRITAIN**

Important - Please read these instructions fully before starting assembly

If you need help or have damaged or missing parts, call the **Customer Helpline: 08456 400800**



Safety and Care Advice

Important - Please read these instructions fully before starting assembly

- **Warning:** This unit weighs approximately 34kgs. Please lift with care.

- Check you have all the components and tools listed on pages 2 and 3.

- Remove all fittings from the plastic bags and separate them into their groups.

- Keep children and animals away from the work area, small parts could choke if swallowed.

- Make sure you have enough space to layout the parts before starting.

- Do not stand or put weight on the product, this could cause damage.

- Assemble the item as close to its final position (in the same room) as possible.

- Assemble on a soft level surface to avoid damaging the unit or your floor (use opened out unit carton).



- We do not recommend the use of power drill/drivers **for inserting screws**, as this could damage the unit. Only use hand screwdrivers.

- **Safety note:** It is recommended that this unit is secured to a wall using the brackets supplied.

- Dispose of all packaging carefully and responsibly.

Care and maintenance

- Only clean using a damp cloth and mild detergent, do not use bleach or abrasive cleaners.

- From time to time check that there are no loose screws on this unit.

- This product should not be discarded with household waste. Take to your local authority waste disposal centre.

Note: If required the next page can be cut out and used as reference throughout the assembly. Keep this page with these instructions for future reference.

Components - Panels

If you have damaged or missing components, call the **Customer Helpline: 08456 400800** quoting the reference numbers below

Please check you have all the panels listed below

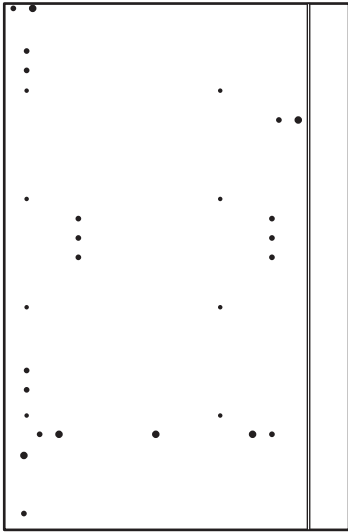

1 Left Side (D0315A)
(870 X 570mm)

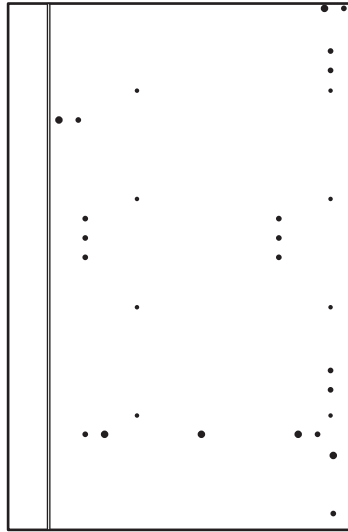

2 Right Side (D0316A)
(870 x 570mm)



3 Top (D0338A)
(500 x 590mm)

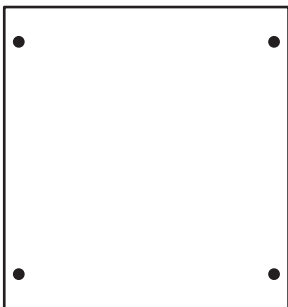

4 Base (D0319A)
(470 X 499mm)

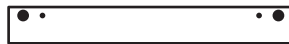

5 Rail (D0321A)
(470 x 60mm) x 2

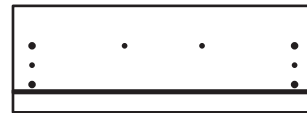

7 Drawer Front (D0318A)
(497 x 176mm) x 4

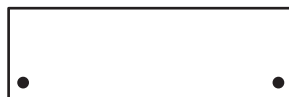

6 Plinth (D0322A)
(470 x 150mm)

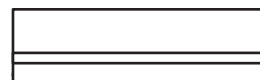

8 Drawer Back (W413BCK)
(422 x 120mm) x 4

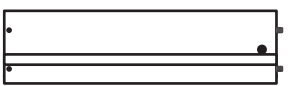

9 Left Drawer Side (W413LH)
(450 x 120mm) x 4

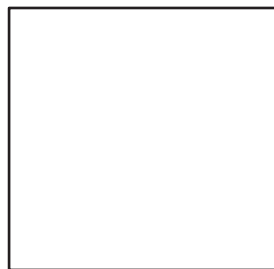

11 Drawer Base (T413)
(447 x 433mm) x 4

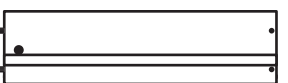

10 Right Drawer Side (W413RH)
(450 x 120mm) x 4

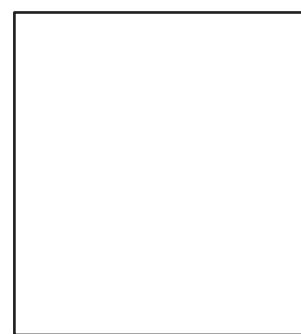

12 Back (X739)
(480 x 533mm)











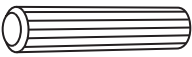
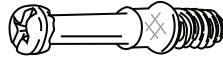

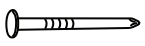
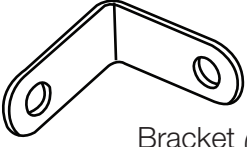

Components - Fittings

If you have damaged or missing components, call the **Customer Helpline: 08456 400800** quoting the reference numbers below

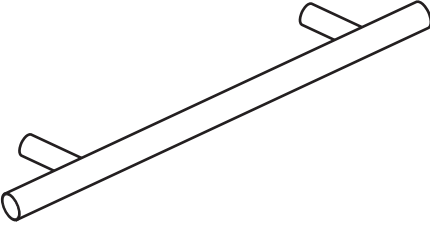
Please check you have all the fittings listed below

Note: The quantities below are the correct amount to complete the assembly. In some cases more fittings may be supplied than are required.

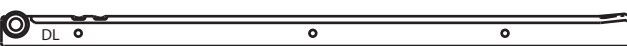
| | | |
|---|--|---|
| <p>A </p> <p>Wooden dowel (F22) x 12</p> | <p>B </p> <p>Metal dowel (F901) x 18</p> | <p>C </p> <p>Large locking nut (F900) x 10</p> |
| <p>D </p> <p>Small locking nut (F3) x 8</p> | <p>E </p> <p>Nail (F51) x 8</p> | <p>F </p> <p>Bracket (F945) x 4</p> |
| <p>G </p> <p>25mm Screw (F50) x 2</p> | <p>H </p> <p>13mm Screw (F79) x 6</p> | <p>I </p> <p>13mm Screw (F63) x 32</p> |
| <p>J </p> <p>Door Buffer (F137) x 8</p> | <p>K </p> <p>45mm Screw (F65) x 16</p> | <p>L a  Handle (F847a) x 4</p> <p>L b  Handle Screw (F847b) x 8</p> |
| <p>M a  CR Runner x 4</p> | | |
| <p>M b  CL Runner x 4</p> | | |
| <p>M c  DR Runner x 4</p> | | |
| <p>M d  DL Runner x 4</p> | | |

Tools required

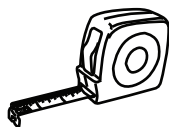

Rule



Cross-head screwdriver



Scissors



Hammer



Eye protection (when using a hammer or drill)



Electric drill

Ruler - Use this ruler to help correctly identify the screws

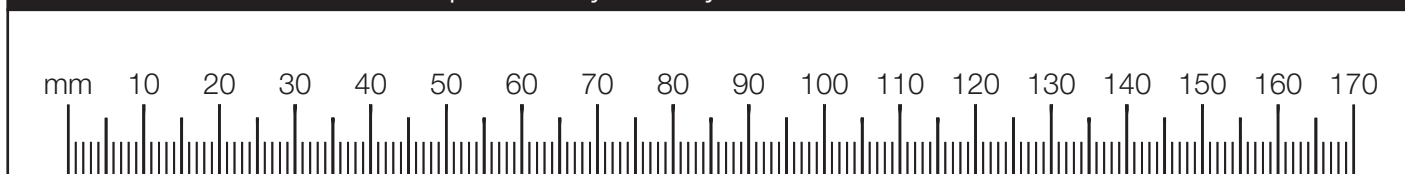

Assembly Instructions

If you have damaged or missing components, call the
Customer Helpline: 08456 400800 quoting the reference
numbers below

Step 1

Prepare 4 drawer fronts

Screw 2 metal dowels **B** into the holes shown on the back of each drawer front **7**.

Note: Tighten metal dowels up fully against the panels.

Stick a drawer buffer **J** into the top corners of each drawer front **7**.

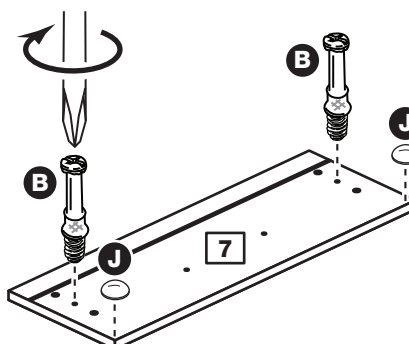
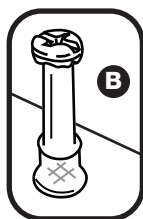

Step 2

Prepare the drawer sides

Insert a small locking nut **D** into the hole shown on the left drawer side **9** and right drawer side **10**.

Note: Arrow on locking nut **must** point towards hole in edge of panel.

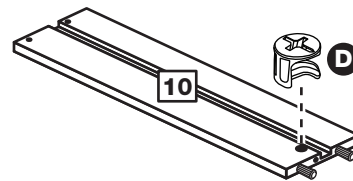
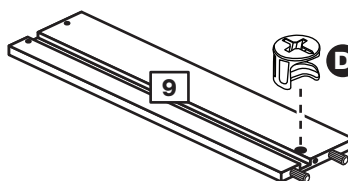
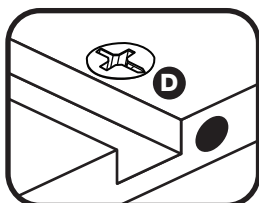

Step 3

Assemble drawer sides and back

Fit the left drawer side **9** and right drawer side **10** to the drawer back **8** using 4 screws **K**.

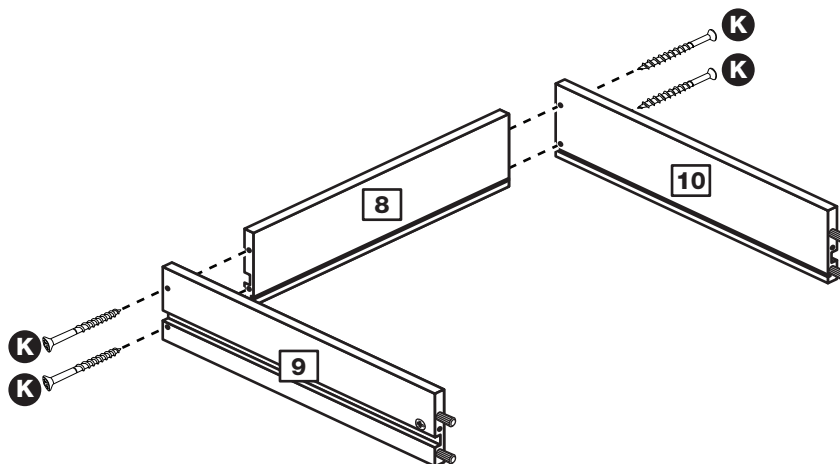

Step 4

Fit drawer base

Slide the drawer base **11** along the grooves of the drawer sides **9** and **10** into the groove of the drawer back **8**.

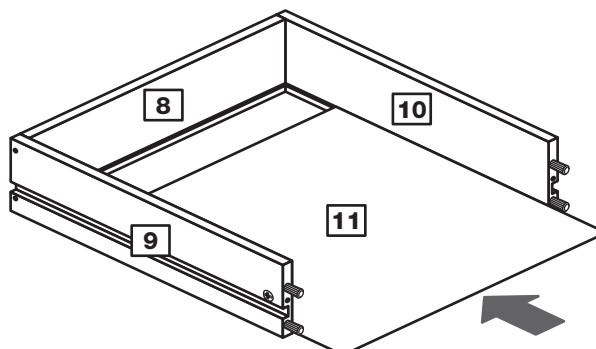

Assembly Instructions

Step 5

Attach drawer front

Turn the drawer assembly over and push onto the back of the drawer front **7**.

Note: Turn locking nuts **D** clockwise to secure panels - more than 1/2 a turn.

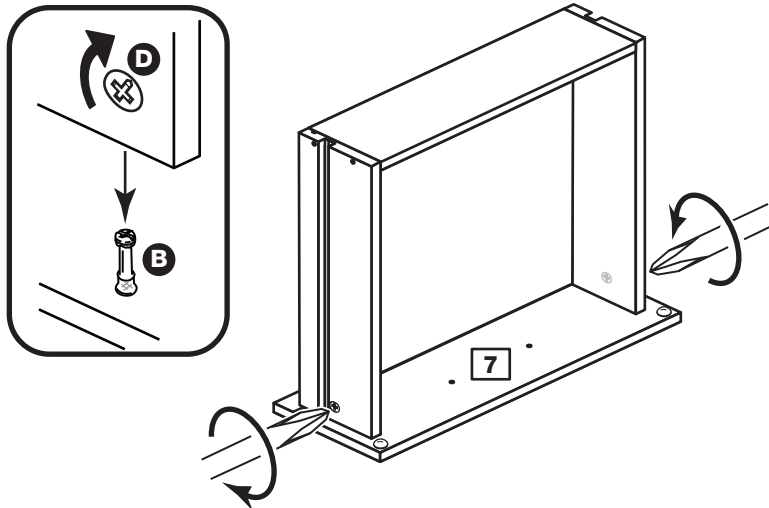

Step 6

Attach 2 handles

Attach each handle **L a** to the drawer fronts **7** using 2 screws **L b**

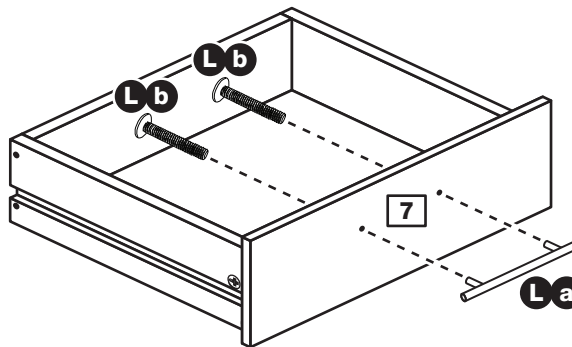

Step 7

Fit runners to the drawers

Turn the 4 drawer assemblies over.

Fit runner **M c**, marked with 'DR', to the bottom edge of the right drawer side **10**, making sure that it is pushed up against the back of the drawer front **7**. Use a bradawl to mark the fixing positions, then secure with 2 screws **I**.

Fit runner **M d**, marked 'DL', to the bottom edge of the left drawer side **9** using the same method.

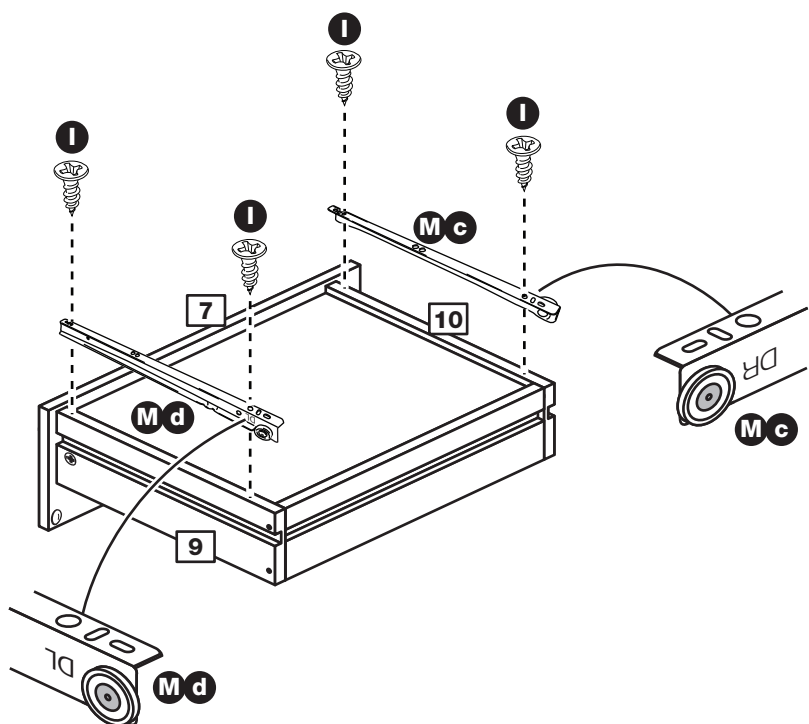

Assembly Instructions

Step 8

Fit 2 brackets to the left side

Fit a bracket **F** to the left side **1**, 100mm in from the back edge, see diagram.

Fit another bracket **F** to the left side **1**, 100mm down from the top edge, see diagram.

Secure each bracket using screw **H**.

Note: The brackets must be flush with the edges of the panel.

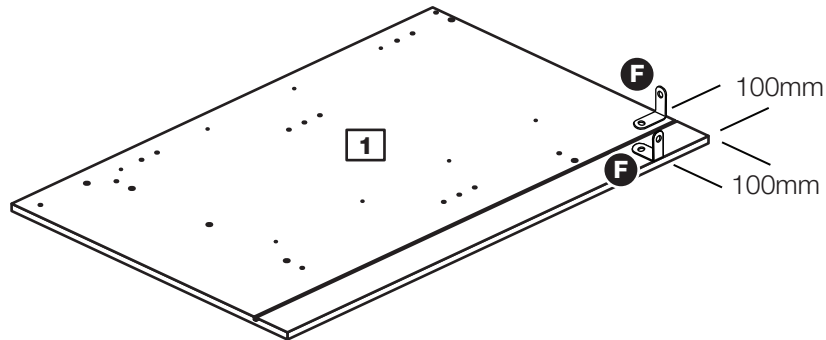
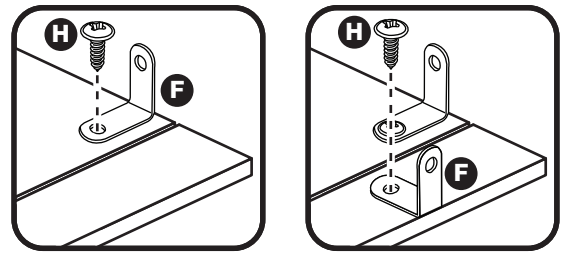

Step 9

Fit runners to the left side

Fit the 4 runners **M b** marked 'CL' to the left side **1**.

The 1st screw **I** uses the 2nd hole in from the front of the runner.

The 2nd screw **I** uses the 6th hole in from the back of the runner.

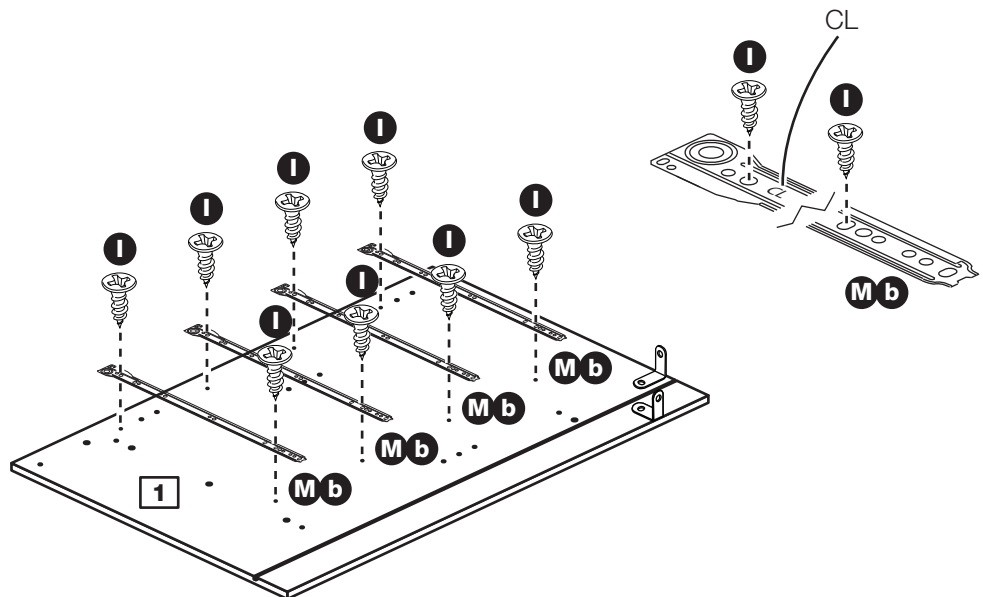

Step 10

Fit metal dowels to the left side

Screw 5 metal dowels **B** into the holes shown on the left side **1**.

Note: Tighten metal dowels up fully against the panels.

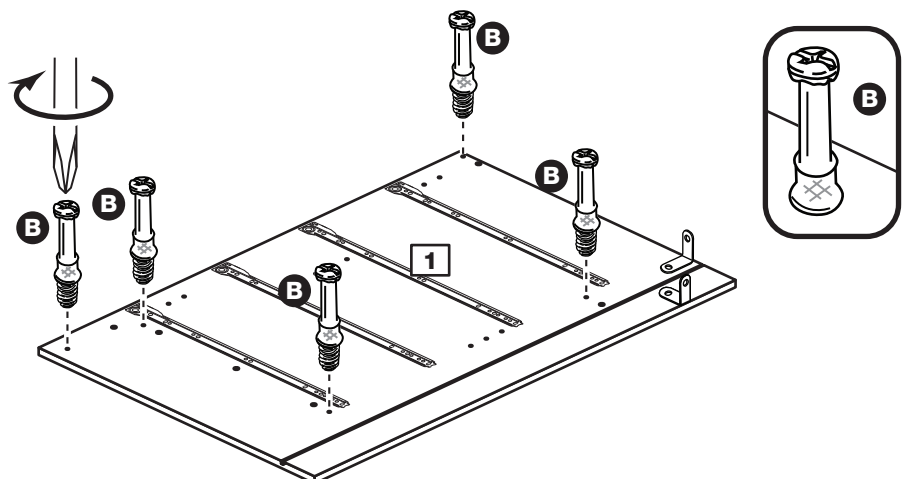

Assembly Instructions

Step 11

Fit 2 brackets to the right side

Fit a bracket **F** to the right side **2**, 100mm down from the back edge, see diagram.

Fit another bracket **F** to the right side **2**, 100mm down from the top edge, see diagram.

Secure each bracket using screw **H**.

Note: The brackets must be flush with the edges of the panel.

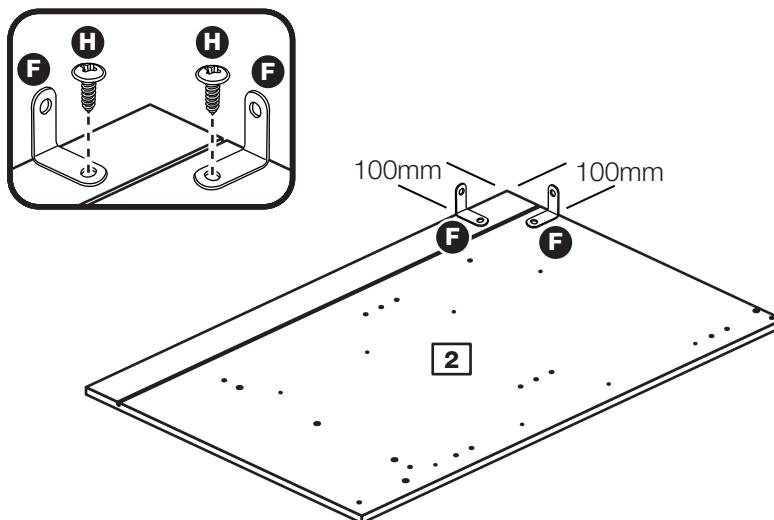

Step 12

Fit runners to the right side

Fit the 4 runners **Ma** marked 'CR' to the right side **2**.

The 1st screw **I** uses the 2nd hole in from the front of the runner.

The 2nd screw **I** uses the 6th hole in from the back of the runner.

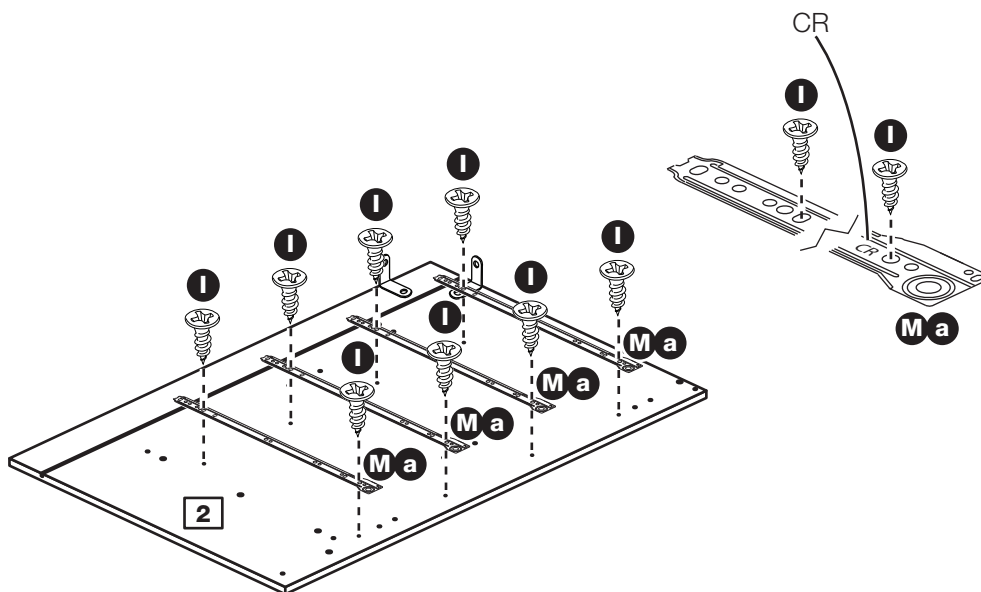

Step 13

Fit metal dowels to the right side

Screw 5 metal dowels **B** into the holes shown on the right side **2**.

Note: Tighten metal dowels up fully against

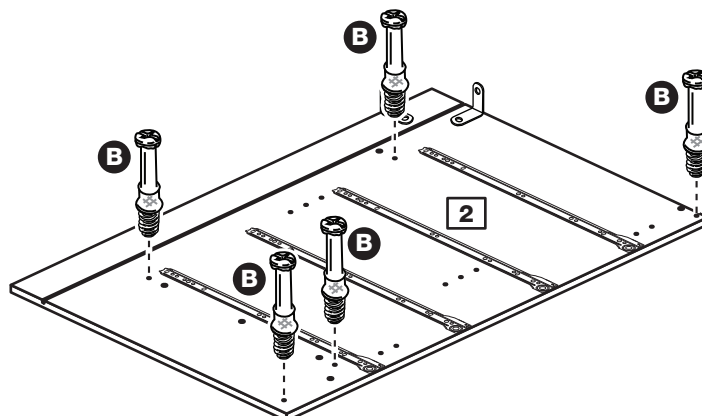

Assembly Instructions

Step 14

Prepare the base

Insert 4 large locking nuts **C** into the base **4** as shown.

Note: Arrow on locking nut **must** point towards hole in edge of panel.

Tap 6 wooden dowels **A** into the base **4** as shown.

Note: Wooden dowels **must not** stick out from the edge by more than 10mm or they may damage other panels.

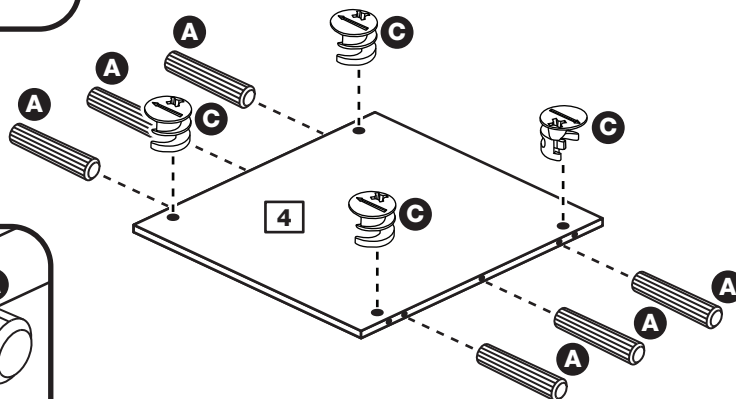
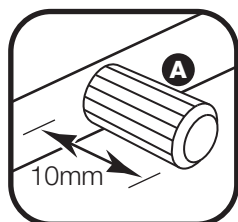
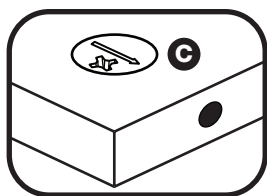

Step 15

Fit the base to the right side

Push the base **4** onto the right side **2**.

Use a screwdriver to tighten the 2 large locking nuts **C** fitted to the base **4**.

Note: Turn the large locking nuts **C** as far as they will go - more than 1/2 a turn.

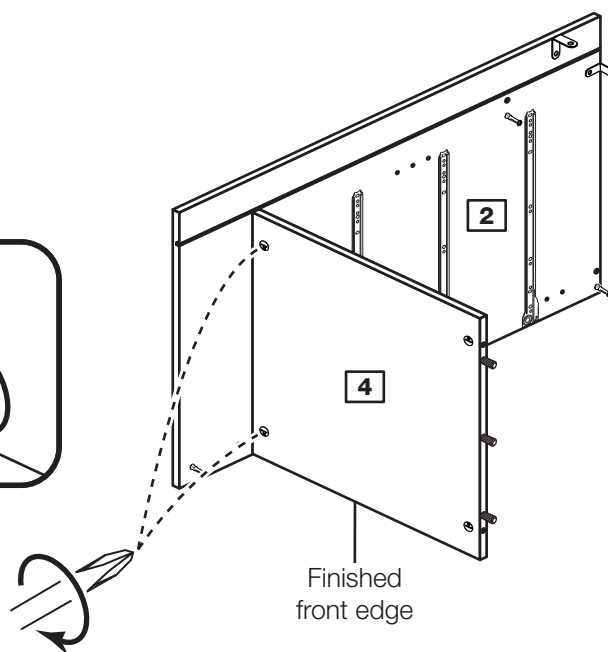
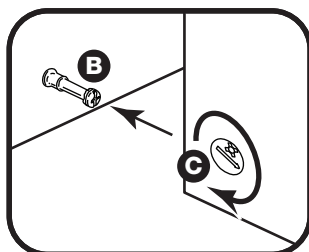

Step 16

Prepare the 2 rails and plinth

Insert 2 large locking nuts **C** into each of the 2 rails **5** and plinth **6** as shown.

Tap 2 wooden dowels **A** into the 2 rails **5** and plinth **6** as shown.

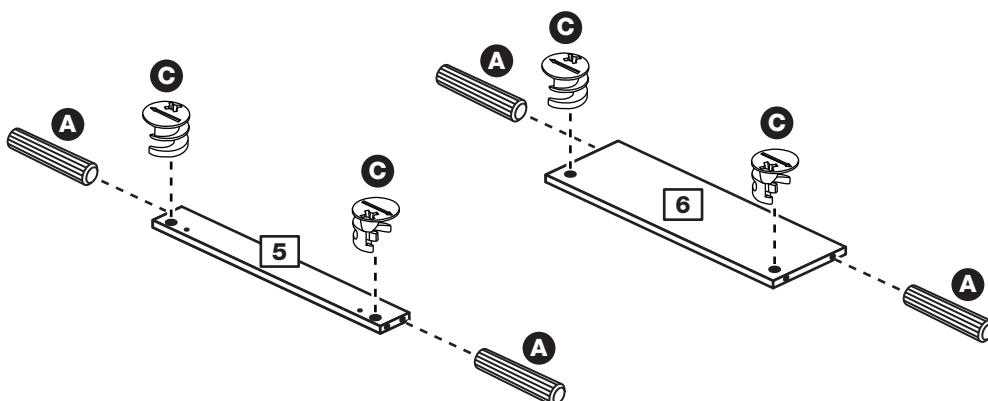

Assembly Instructions

Step 17

Fit the 2 rails and plinth

One at a time, push the 2 rails **5** and plinth **6** onto the right side **2** as shown.

Use a screwdriver to tighten the 3 large locking nuts **C** fitted to the 3 panels, as shown.

Note: Turn the large locking nuts **C** as far as they will go - more than 1/2 a turn.

Note: Support the rail near the back edge of the unit until the left side has been fitted in the next stage.

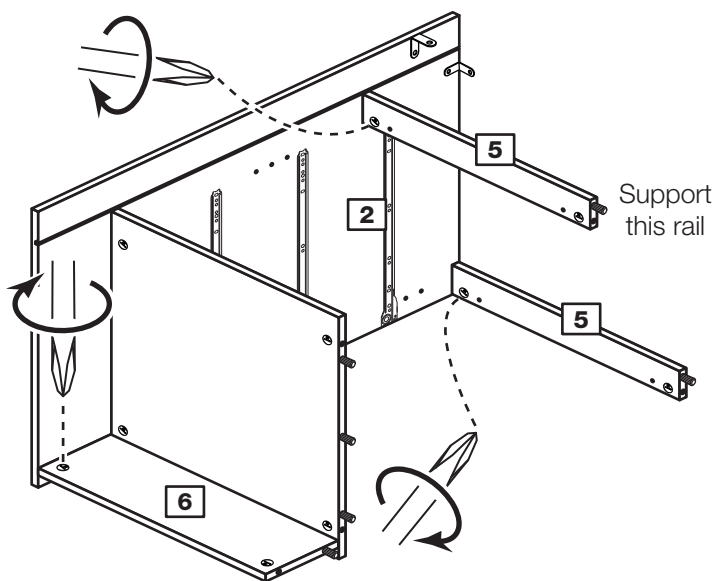

Step 18

Fit the left side

Push the left side **1** onto the assembly.

Use a screwdriver to tighten the 5 large locking nuts **C** fitted to the base **4**, rails **5** and plinth **6**.

Note: Turn the large locking nuts **C** as far as they will go - more than 1/2 a turn.

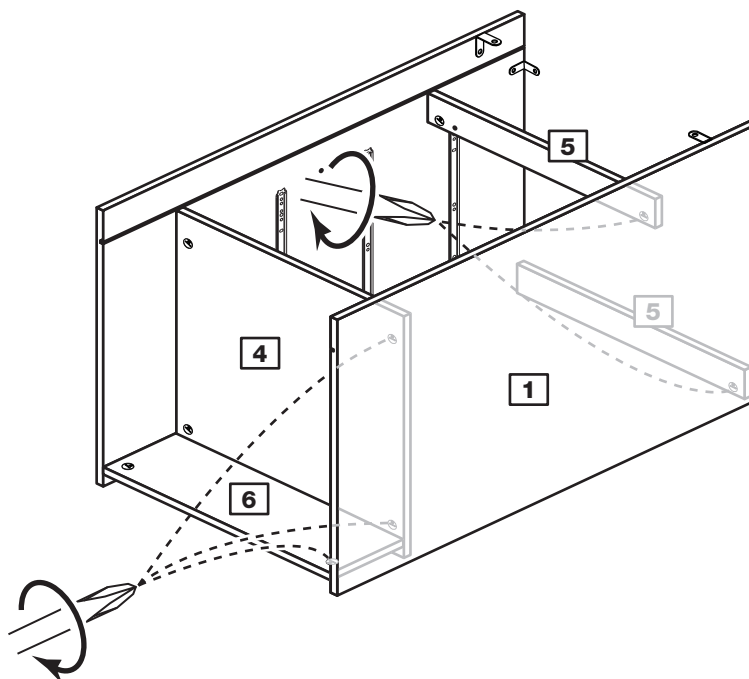

Assembly Instructions

Step 19

Fit the back

a: Square up the unit by making sure that measurement **x to x** equals **y to y**.

b: Slide the back **12** into the grooves along the left **1** and right **2** sides, as shown.

c: Secure the back **12** by tapping 4 nails **E** down into the back edge of the base **4** and 4 nails **E** into the back edge of the rail **5**.

Stand the unit up for the next stage.

a: The measurement from top corner X to bottom corner X must be equal to the measurement from top corner Y to bottom corner Y

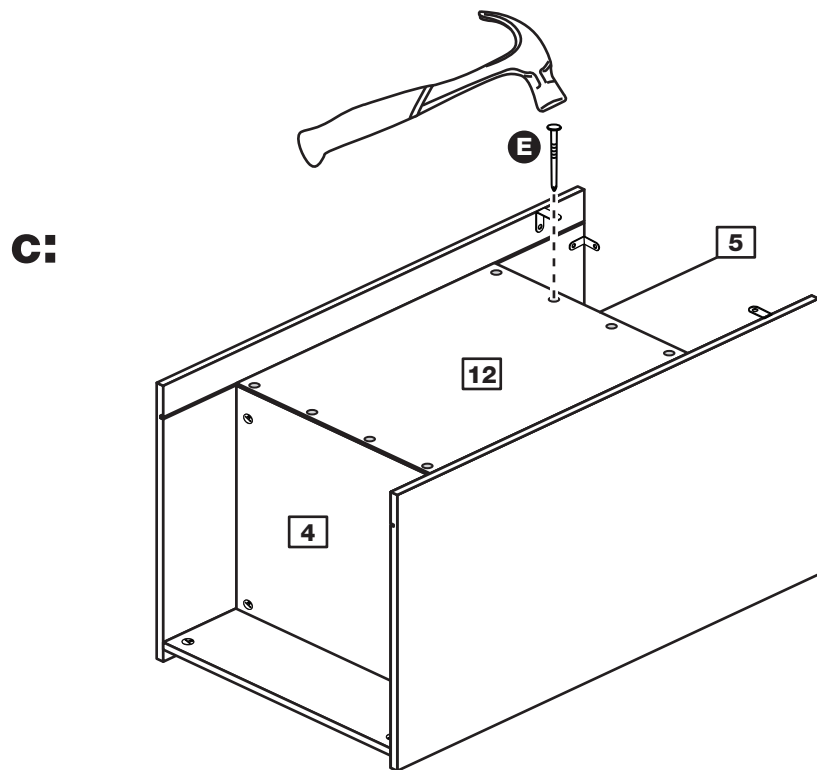
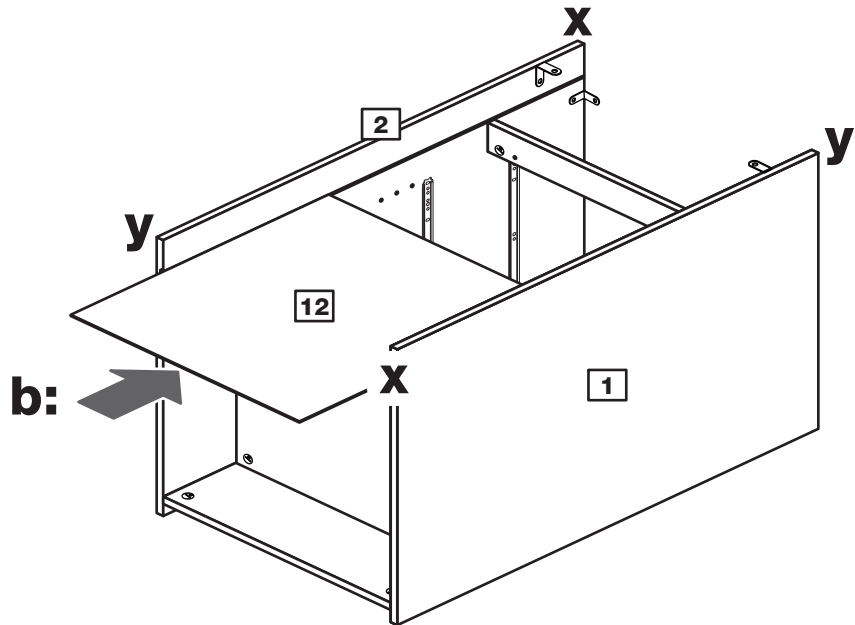

Assembly Instructions

Step 20

Fit the top

Position the top **3** onto the unit, making sure that the back edge is flush with the back edge of the sides **1** and **2**.

Secure the top **3** using screw **H** through the 2 brackets **F** fitted at the top edge of the side panels **1** and **2**.

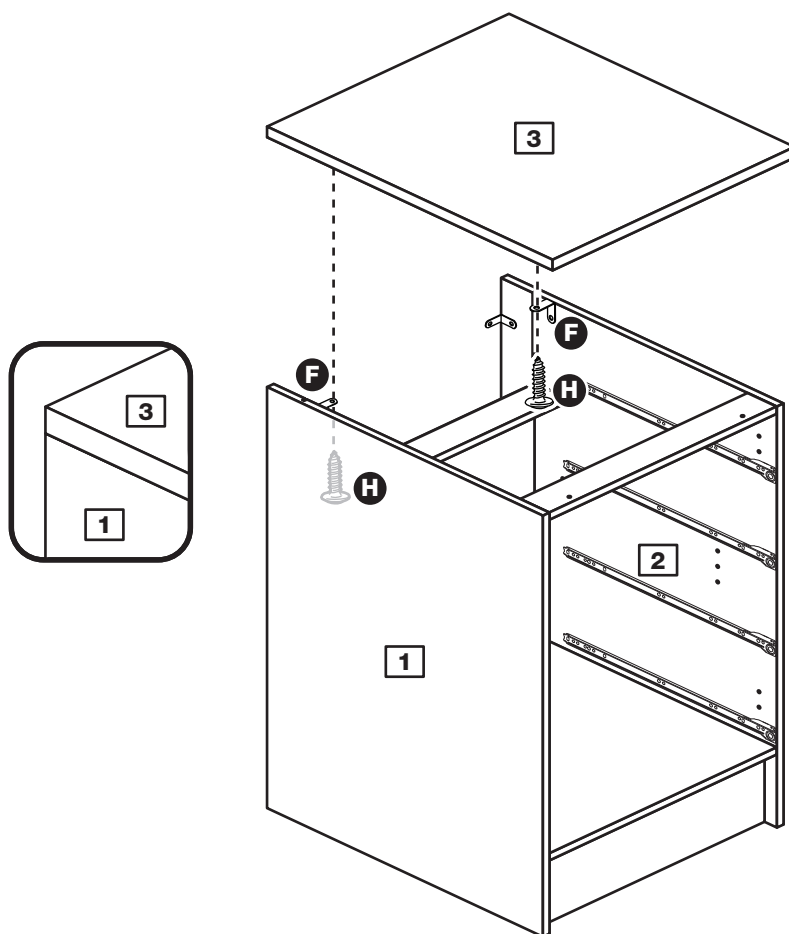

Step 21

Secure the front of the top

To secure the front of the top **3**, screw up through the 2 holes in the rail **5** at the front of the unit using screws **G**.

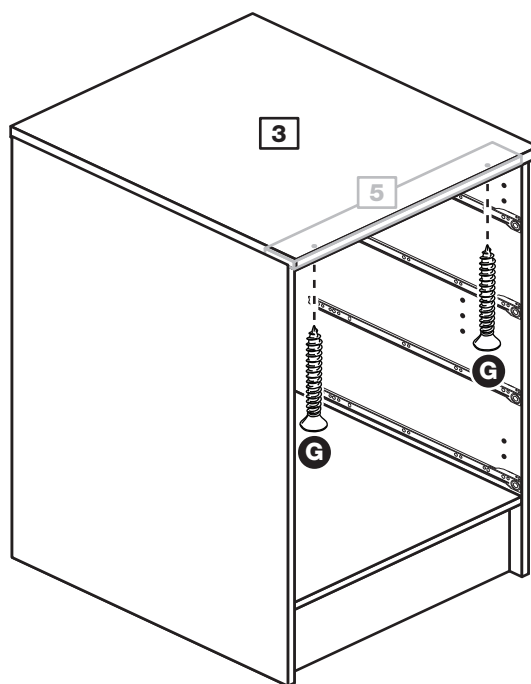

Assembly Instructions

Step 22

Secure the unit to the wall

Using the brackets **F** fitted to the back edge of the sides **1** and **2** screw the unit to the wall.

Fixings are not supplied as they will need to suit the wall type, and the length of screw will depend on the distance of the back of the Unit to the wall.



Warning: Take care when drilling the wall that you do not drill into any pipes, wires etc. If in doubt, consult an expert.

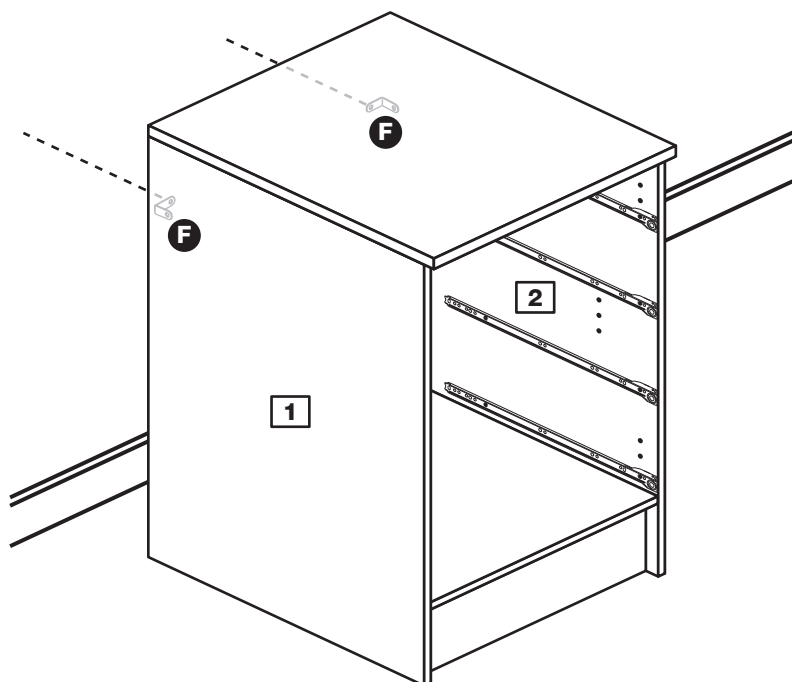

Step 23

Fit the drawers

Slide the wheels on the runners fitted to the drawer sides over the wheels on the runners fitted to the side panels and push the drawer into position.

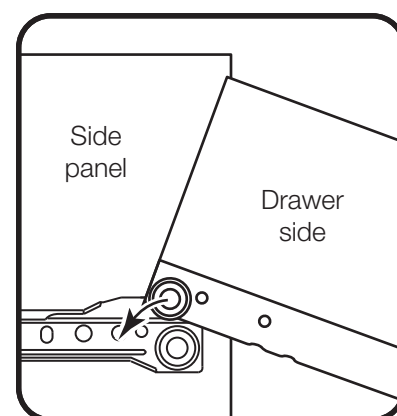
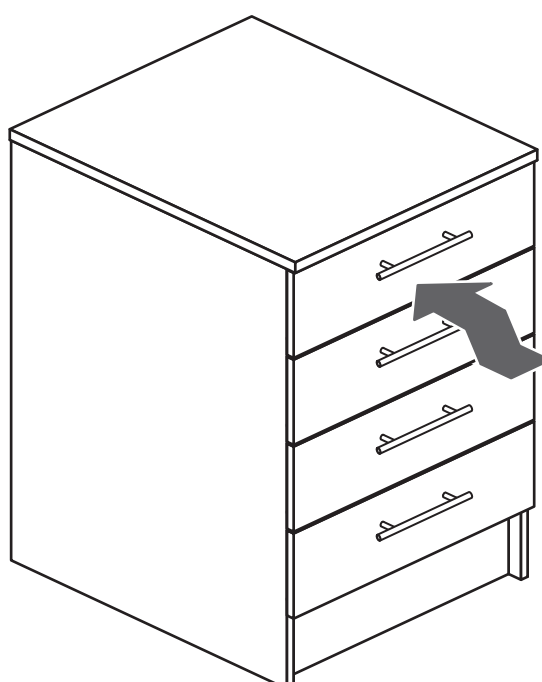

Assembly Instructions

Step 24

Assembly is complete



Warning: The unit is heavy. Lift with care.

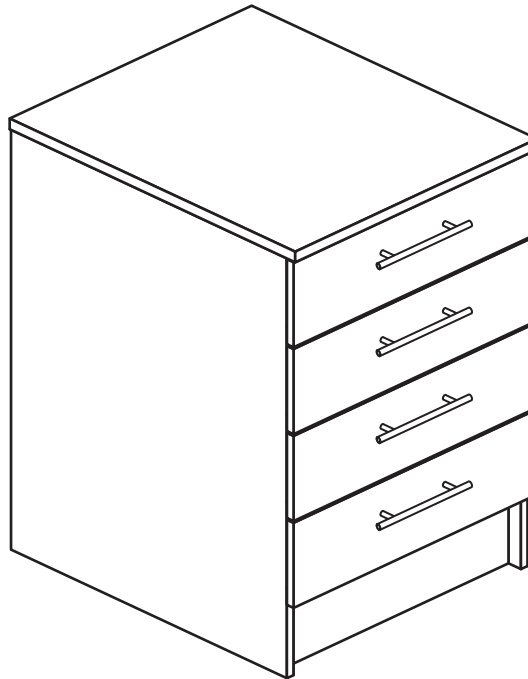

If you need help or have damaged or missing parts, call the **Customer Helpline: 08456 400800** and quote the reference numbers on the component pages.

Argos Ltd, 489-499 Avebury Boulevard, Central Milton Keynes, MK9 2NW

Athina - 500 Drawer Unit

Assembly Instructions - Please keep for future reference

608/0804

608/0921

608/0866

608/0983

608/2974



Dimensions

Width - 50cm

Depth - 59cm

Height - 89.5cm



**MADE IN
BRITAIN**

Important - Please read these instructions fully before starting assembly

If you need help or have damaged or missing parts, call the **Customer Helpline: 08456 400800**



Safety and Care Advice

Important - Please read these instructions fully before starting assembly

- **Warning:** This unit weighs approximately 34kgs. Please lift with care.

- Check you have all the components and tools listed on pages 2 and 3.

- Remove all fittings from the plastic bags and separate them into their groups.

- Keep children and animals away from the work area, small parts could choke if swallowed.

- Make sure you have enough space to layout the parts before starting.

- Do not stand or put weight on the product, this could cause damage.

- Assemble the item as close to its final position (in the same room) as possible.

- Assemble on a soft level surface to avoid damaging the unit or your floor (use opened out unit carton).



- We do not recommend the use of power drill/drivers **for inserting screws**, as this could damage the unit. Only use hand screwdrivers.

- **Safety note:** It is recommended that this unit is secured to a wall using the brackets supplied.

- Dispose of all packaging carefully and responsibly.

Care and maintenance

- Only clean using a damp cloth and mild detergent, do not use bleach or abrasive cleaners.

- From time to time check that there are no loose screws on this unit.

- This product should not be discarded with household waste. Take to your local authority waste disposal centre.

Note: If required the next page can be cut out and used as reference throughout the assembly. Keep this page with these instructions for future reference.

Components - Panels

If you have damaged or missing components, call the **Customer Helpline: 08456 400800** quoting the reference numbers below

Please check you have all the panels listed below

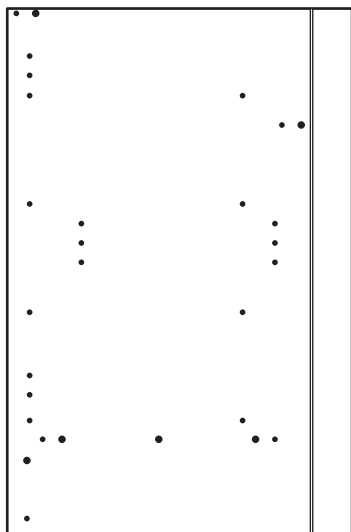

1 Left Side (D0315B)
(870 X 570mm)

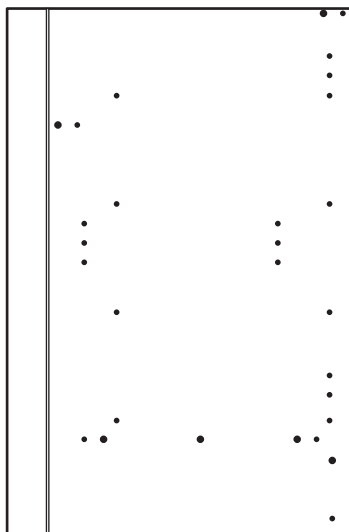

2 Right Side (D0316B)
(870 x 570mm)

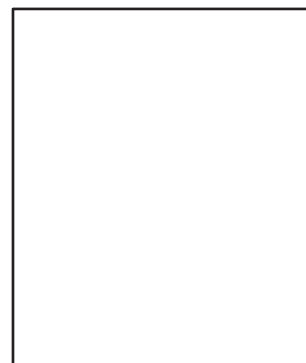

3 Top (D0338A)
(500 x 590mm)

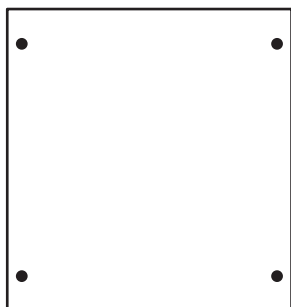

4 Base (D0319A)
(470 X 499mm)

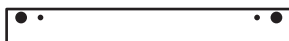

5 Rail (D0321A)
(470 x 60mm) x 2

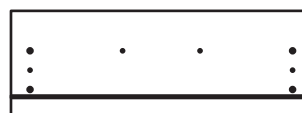

7 Drawer Front (D0318A)
(497 x 176mm) x 4



6 Plinth (D0322A)
(470 x 150mm)

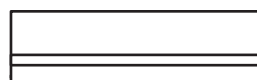

8 Drawer Back (W413BCK)
(422 x 120mm) x 4

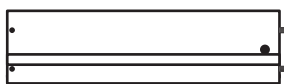

9 Left Drawer Side (W413LH)
(450 x 120mm) x 4

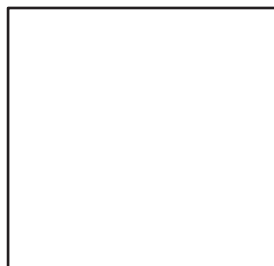

11 Drawer Base (T413)
(447 x 433mm) x 4

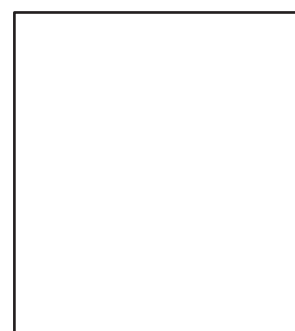

12 Back (X739)
(480 x 533mm)

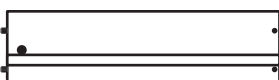

10 Right Drawer Side (W413RH)
(450 x 120mm) x 4











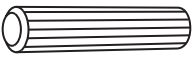
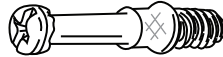

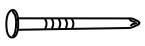
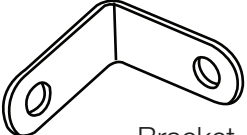
Components - Fittings

If you have damaged or missing components, call the **Customer Helpline: 08456 400800** quoting the reference numbers below

Please check you have all the fittings listed below

Note: The quantities below are the correct amount to complete the assembly. In some cases more fittings may be supplied than are required.

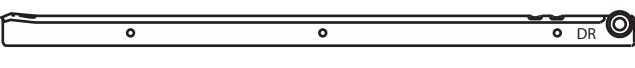
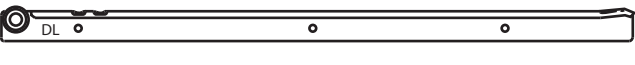
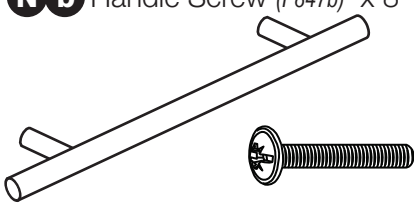
| | | |
|---|--|---|
| <p>A </p> <p>Wooden dowel (F22) x 12</p> | <p>B </p> <p>Metal dowel (F901) x 18</p> | <p>C </p> <p>Large locking nut (F900) x 10</p> |
| <p>D </p> <p>Small locking nut (F3) x 8</p> | <p>E </p> <p>Nail (F51) x 8</p> | <p>F </p> <p>Bracket (F945) x 4</p> |
| <p>G </p> <p>25mm Screw (F50) x 2</p> | <p>H </p> <p>13mm Screw (F79) x 6</p> | <p>I </p> <p>13mm Screw (F63) x 16</p> |
| <p>J </p> <p>Door Buffer (F137) x 8</p> | <p>K </p> <p>45mm Screw (F65) x 16</p> | <p>L </p> <p>13mm Screw (F52) x 16</p> |
| <p>M a  CR Runner (F133) x 4</p> <p>M b  CL Runner (F134) x 4</p> <p>M c  DR Runner (F135) x 4</p> <p>M d  DL Runner (F136) x 4</p> | | <p>N a Handle (F847a) x 4</p> <p>N b Handle Screw (F847b) x 8</p>  |

Tools required

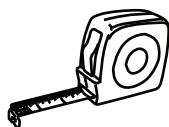

Rule



Scissors



Cross-head screwdriver



Hammer



Eye protection (when using a hammer or drill)



Electric drill

Ruler - Use this ruler to help correctly identify the screws

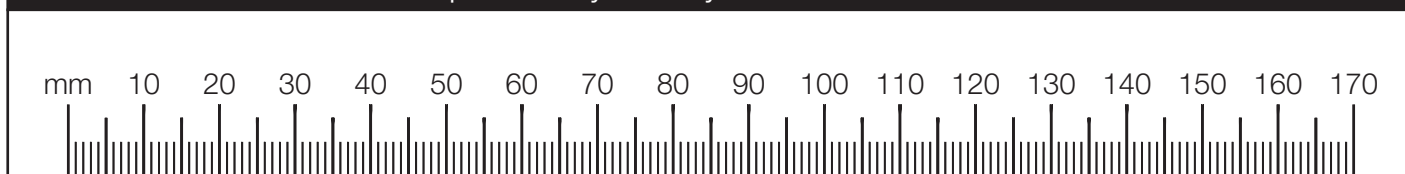

Assembly Instructions

If you have damaged or missing components, call the
Customer Helpline: 08456 400800 quoting the reference
numbers below

Step 1

Prepare 4 drawer fronts

Screw 2 metal dowels **B** into the holes shown on the back of each drawer front **7**.

Note: Tighten metal dowels up fully against the panels.

Stick a drawer buffer **J** into the top corners of each drawer front **7**.

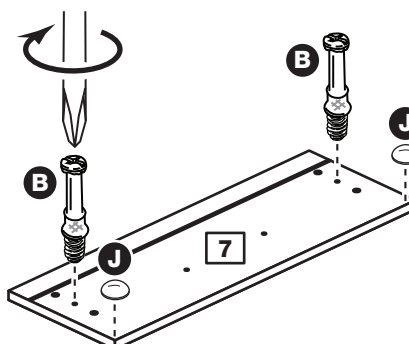
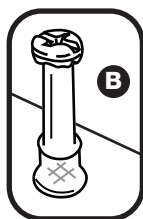

Step 2

Prepare the drawer sides

Insert a small locking nut **D** into the hole shown on the left drawer side **9** and right drawer side **10**.

Note: Arrow on locking nut **must** point towards hole in edge of panel.

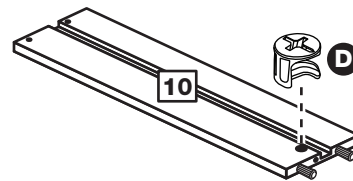
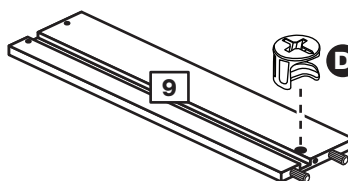
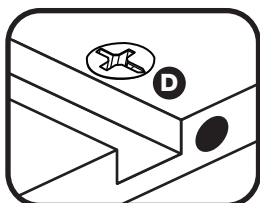

Step 3

Assemble drawer sides and back

Fit the left drawer side **9** and right drawer side **10** to the drawer back **8** using 4 screws **K**.

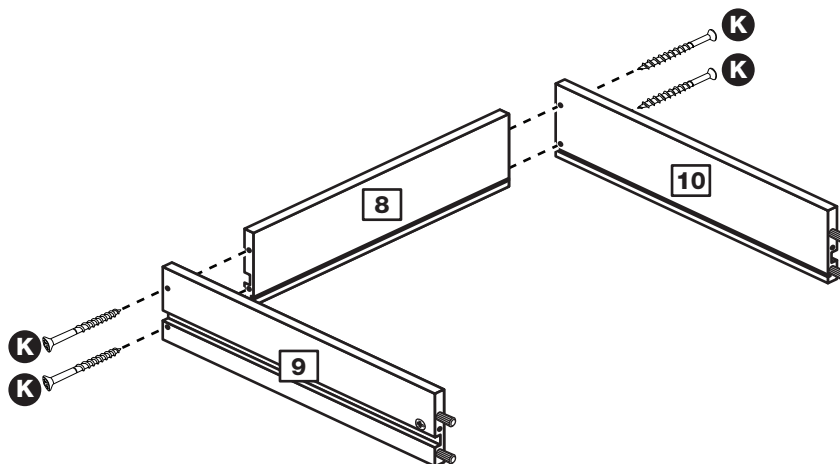

Step 4

Fit drawer base

Slide the drawer base **11** along the grooves of the drawer sides **9** and **10** into the groove of the drawer back **8**.

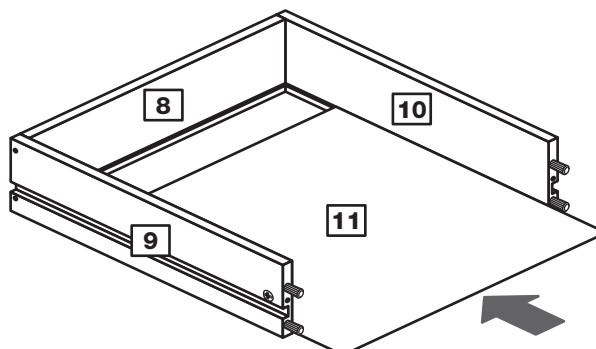

Assembly Instructions

Step 5

Attach drawer front

Turn the drawer assembly over and push onto the back of the drawer front **7**.

Note: Turn locking nuts **D** clockwise to secure panels - more than 1/2 a turn.

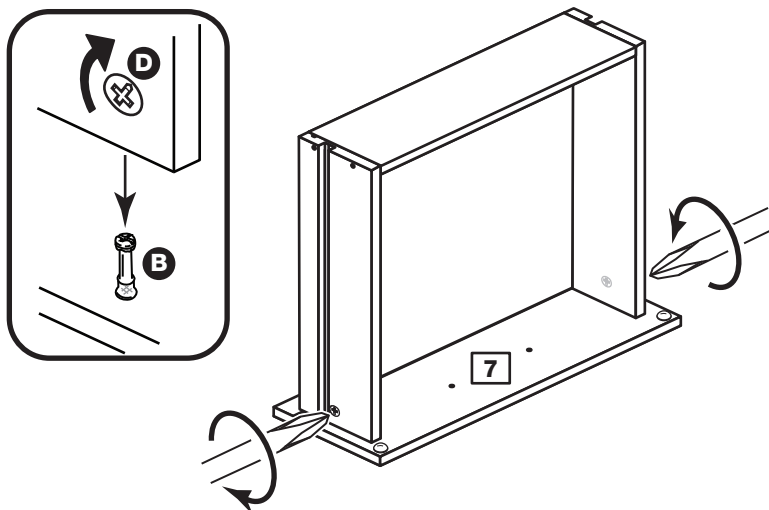

Step 6

Attach 2 handles

Attach each handle **N a** to the drawer fronts **7** using 2 screws **N b**

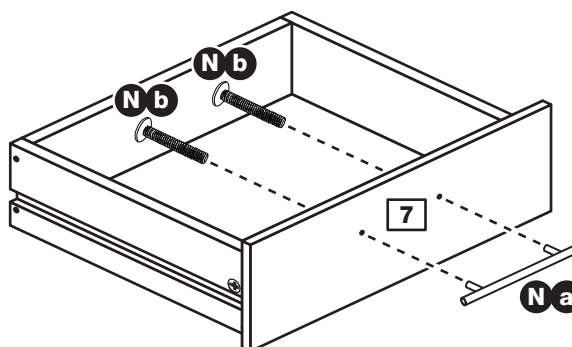

Step 7

Fit runners to the drawers

Turn the 4 drawer assemblies over.

Fit runner **M c**, marked with 'DR', to the bottom edge of the right drawer side **10**, making sure that it is pushed up against the back of the drawer front **7**. Use a bradawl to mark the fixing positions, then secure with 2 screws **I**.

Fit runner **M d**, marked 'DL', to the bottom edge of the left drawer side **9** using the same method.

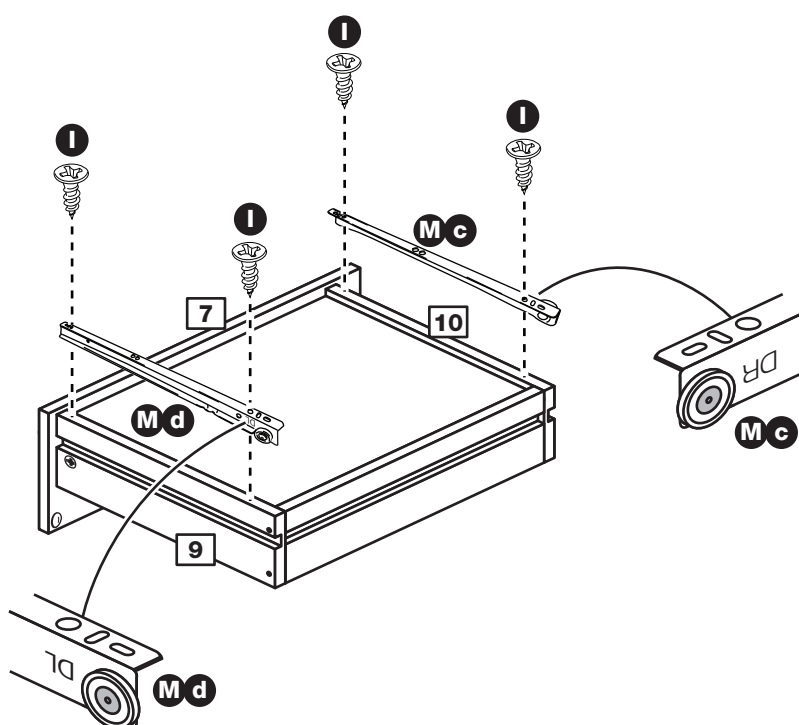

Assembly Instructions

Step 8

Fit 2 brackets to the left side

Fit a bracket **F** to the left side **1**, 100mm in from the back edge, see diagram.

Fit another bracket **F** to the left side **1**, 100mm down from the top edge, see diagram.

Secure each bracket using screw **H**.

Note: The brackets must be flush with the edges of the panel.

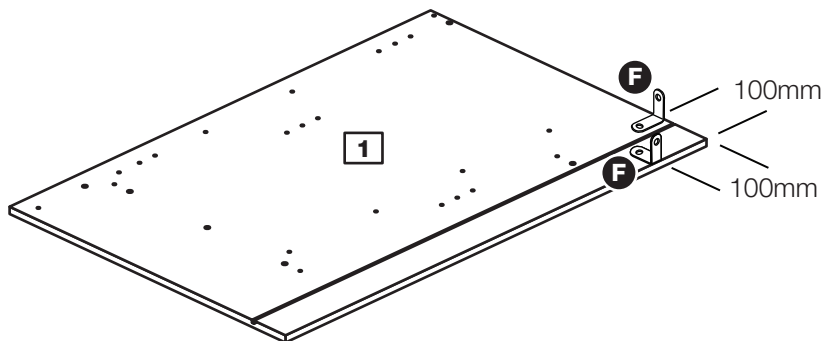
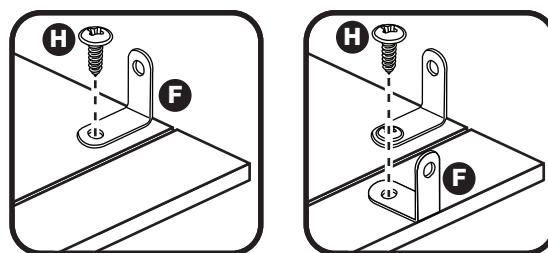

Step 9

Fit runners to the left side

Fit the 4 runners **M b** marked 'CL' to the left side **1**.

The 1st screw **L** uses the 2nd hole in from the front of the runner.

The 2nd screw **L** uses the 4th hole in from the back of the runner.

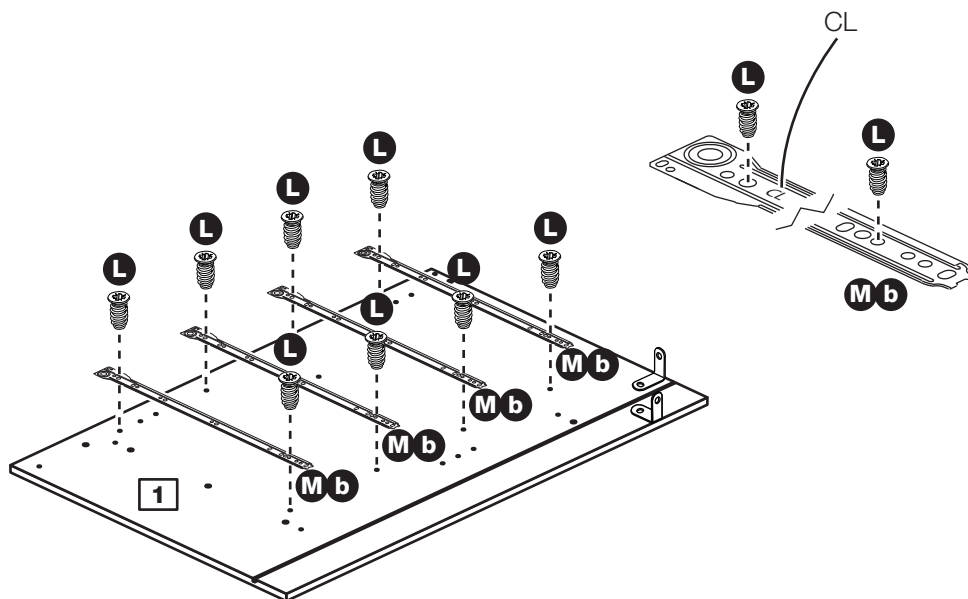

Step 10

Fit metal dowels to the left side

Screw 5 metal dowels **B** into the holes shown on the left side **1**.

Note: Tighten metal dowels up fully against the panels.

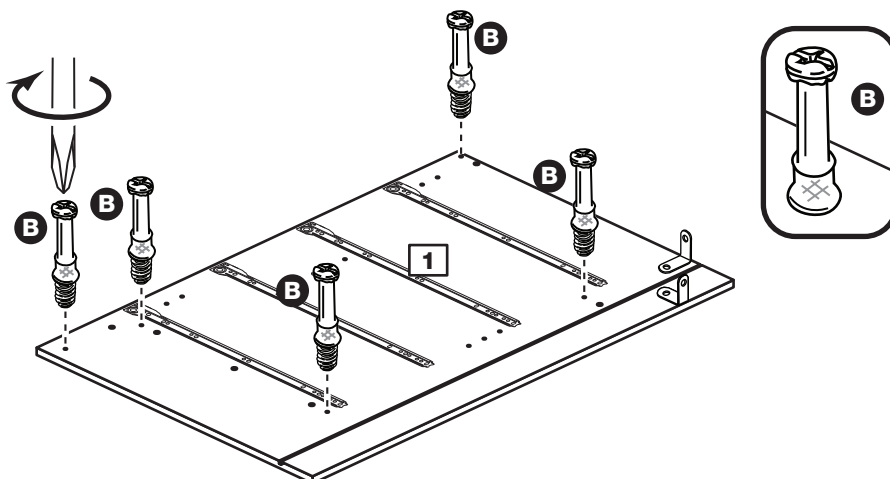

Assembly Instructions

Step 11

Fit 2 brackets to the right side

Fit a bracket **F** to the right side **2**, 100mm down from the back edge, see diagram.

Fit another bracket **F** to the right side **2**, 100mm down from the top edge, see diagram.

Secure each bracket using screw **H**.

Note: The brackets must be flush with the edges of the panel.

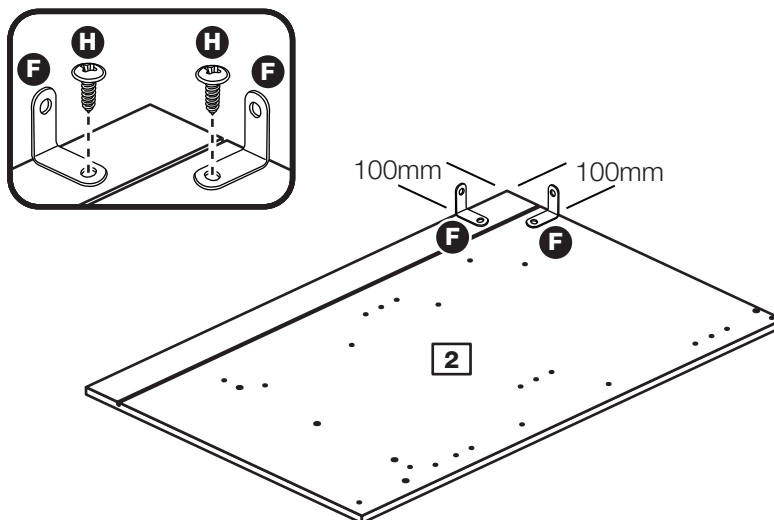

Step 12

Fit runners to the right side

Fit the 4 runners **Ma** marked 'CR' to the right side **2**.

The 1st screw **L** uses the 2nd hole in from the front of the runner.

The 2nd screw **L** uses the 4th hole in from the back of the runner.

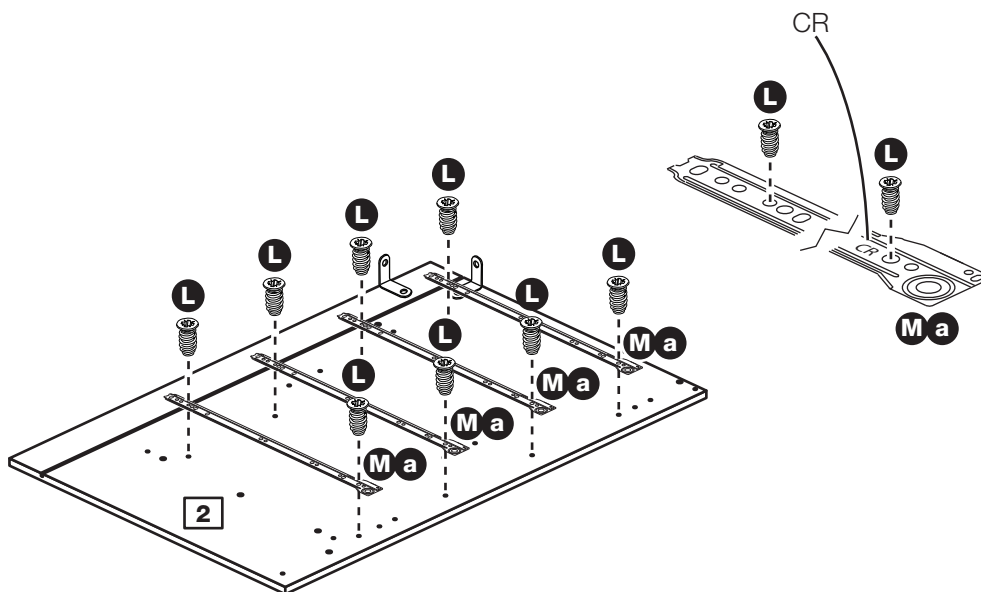

Step 13

Fit metal dowels to the right side

Screw 5 metal dowels **B** into the holes shown on the right side **2**.

Note: Tighten metal dowels up fully against

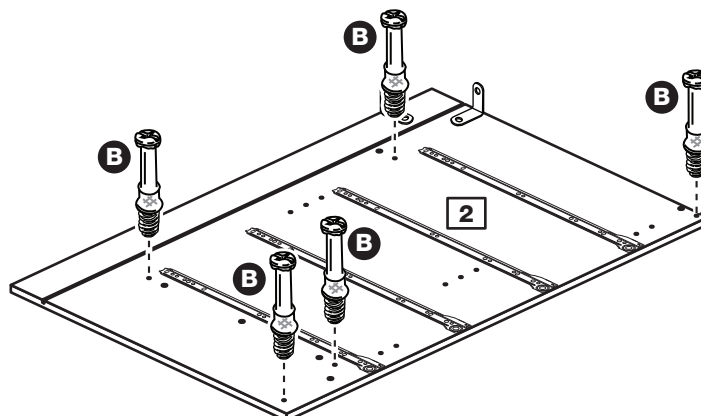

Assembly Instructions

Step 14

Prepare the base

Insert 4 large locking nuts **C** into the base **4** as shown.

Note: Arrow on locking nut **must** point towards hole in edge of panel.

Tap 6 wooden dowels **A** into the base **4** as shown.

Note: Wooden dowels **must not** stick out from the edge by more than 10mm or they may damage other panels.

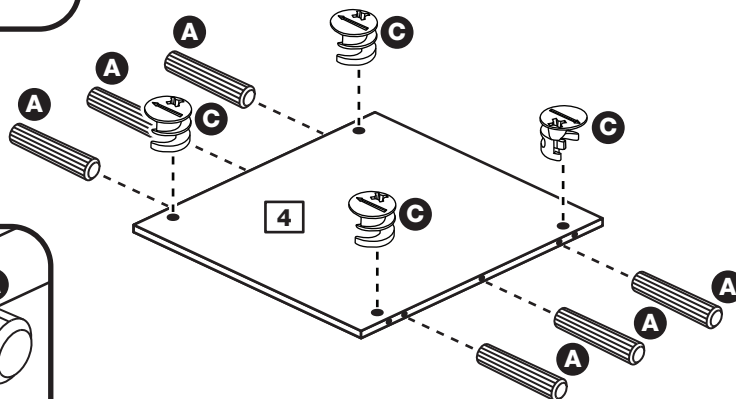
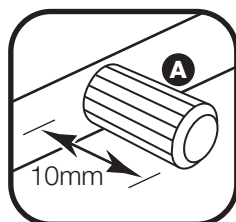
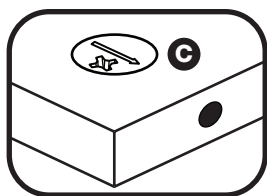

Step 15

Fit the base to the right side

Push the base **4** onto the right side **2**.

Use a screwdriver to tighten the 2 large locking nuts **C** fitted to the base **4**.

Note: Turn the large locking nuts **C** as far as they will go - more than 1/2 a turn.

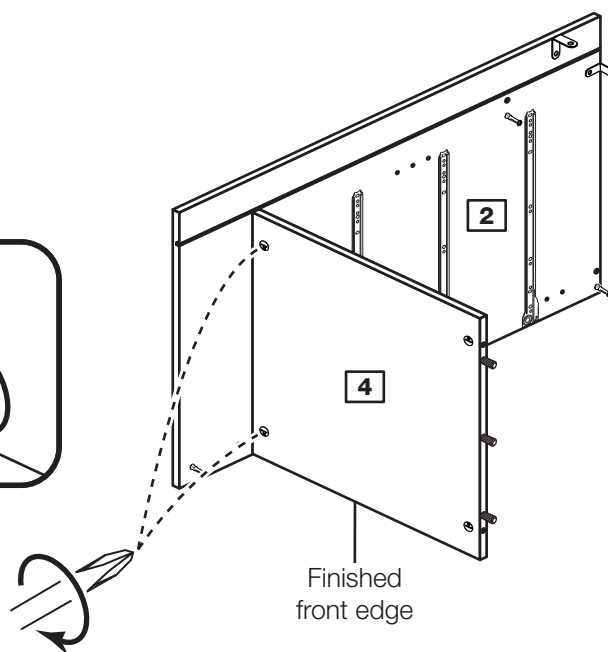
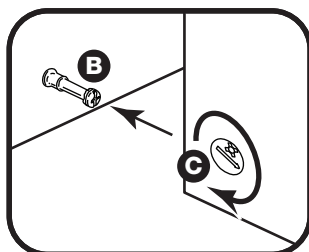

Step 16

Prepare the 2 rails and plinth

Insert 2 large locking nuts **C** into each of the 2 rails **5** and plinth **6** as shown.

Tap 2 wooden dowels **A** into the 2 rails **5** and plinth **6** as shown.

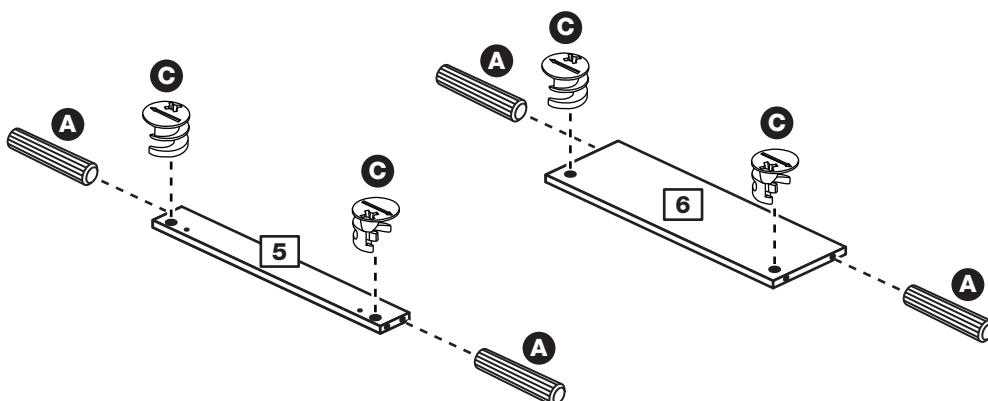

Assembly Instructions

Step 17

Fit the 2 rails and plinth

One at a time, push the 2 rails **5** and plinth **6** onto the right side **2** as shown.

Use a screwdriver to tighten the 3 large locking nuts **C** fitted to the 3 panels, as shown.

Note: Turn the large locking nuts **C** as far as they will go - more than 1/2 a turn.

Note: Support the rail near the back edge of the unit until the left side has been fitted in the next stage.

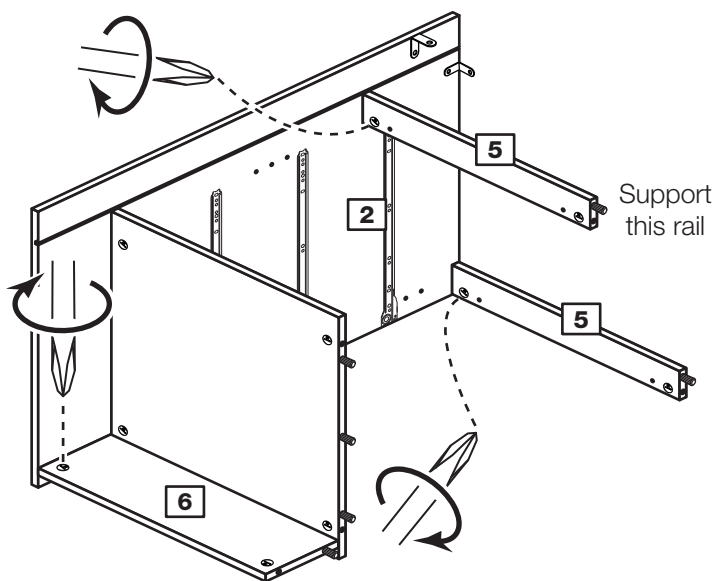

Step 18

Fit the left side

Push the left side **1** onto the assembly.

Use a screwdriver to tighten the 5 large locking nuts **C** fitted to the base **4**, rails **5** and plinth **6**.

Note: Turn the large locking nuts **C** as far as they will go - more than 1/2 a turn.

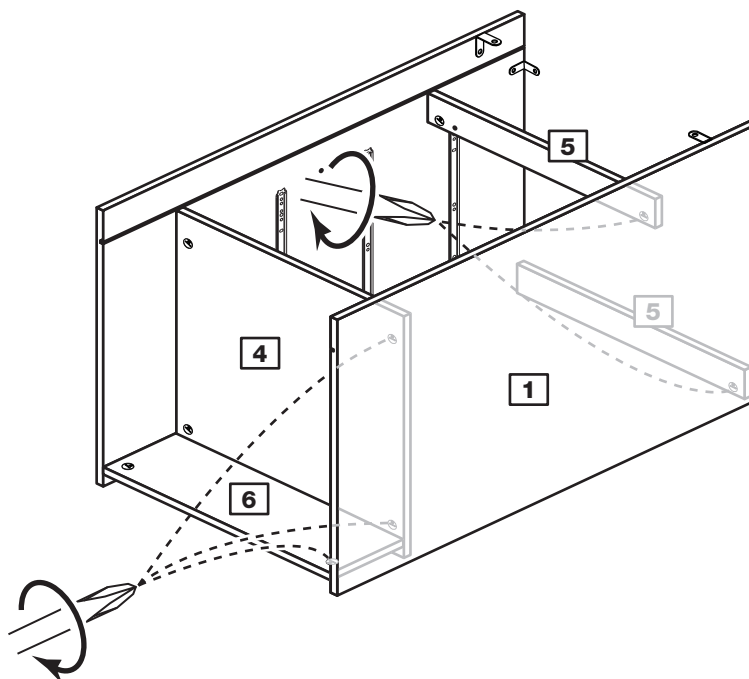

Assembly Instructions

Step 19

Fit the back

a: Square up the unit by making sure that measurement **x to x** equals **y to y**.

b: Slide the back **12** into the grooves along the left **1** and right **2** sides, as shown.

c: Secure the back **12** by tapping 4 nails **E** down into the back edge of the base **4** and 4 nails **E** into the back edge of the rail **5**.

Stand the unit up for the next stage.

a: The measurement from top corner X to bottom corner X must be equal to the measurement from top corner Y to bottom corner Y

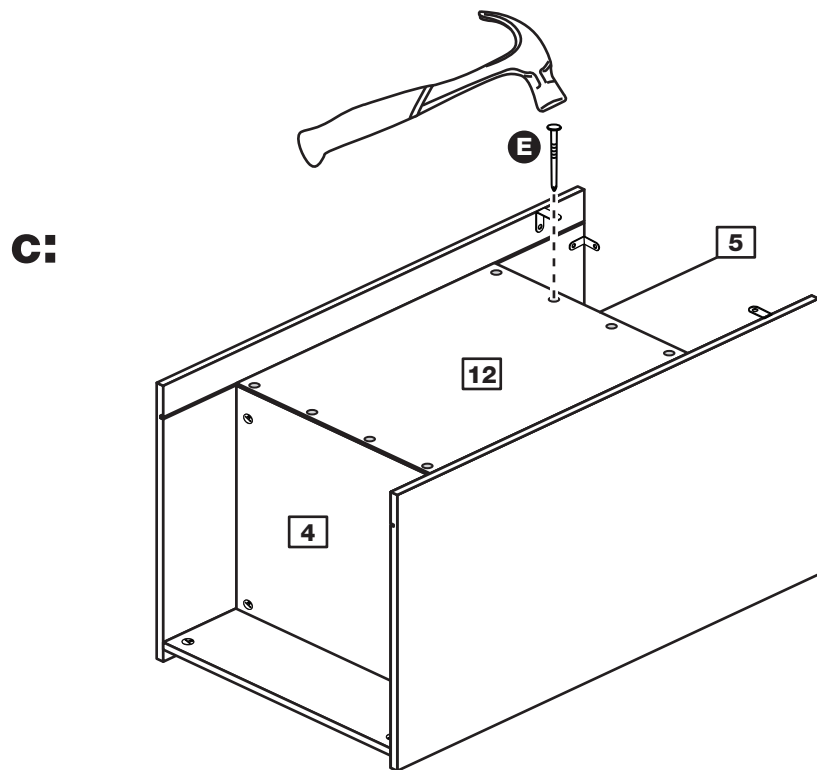
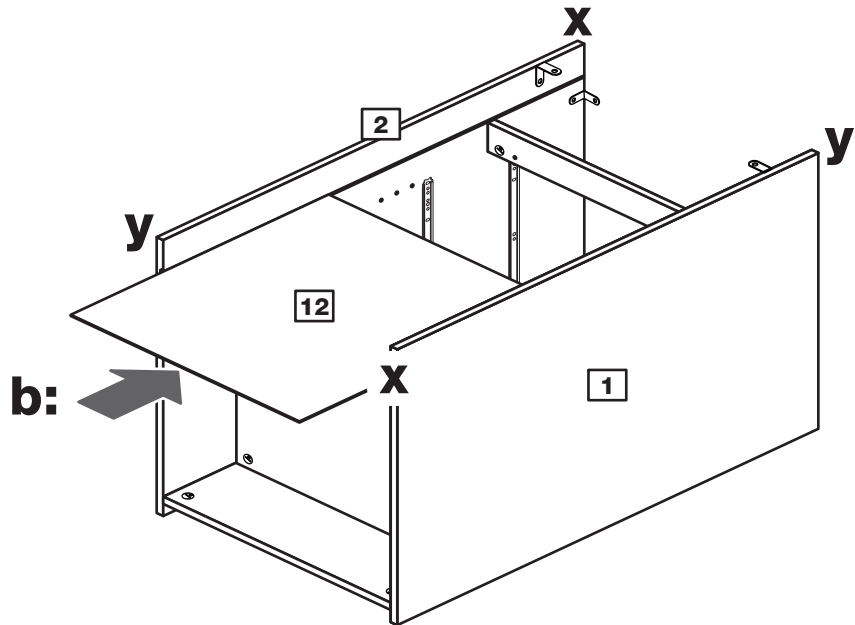

Assembly Instructions

Step 20

Fit the top

Position the top **3** onto the unit, making sure that the back edge is flush with the back edge of the sides **1** and **2**.

Secure the top **3** using screw **H** through the 2 brackets **F** fitted at the top edge of the side panels **1** and **2**.

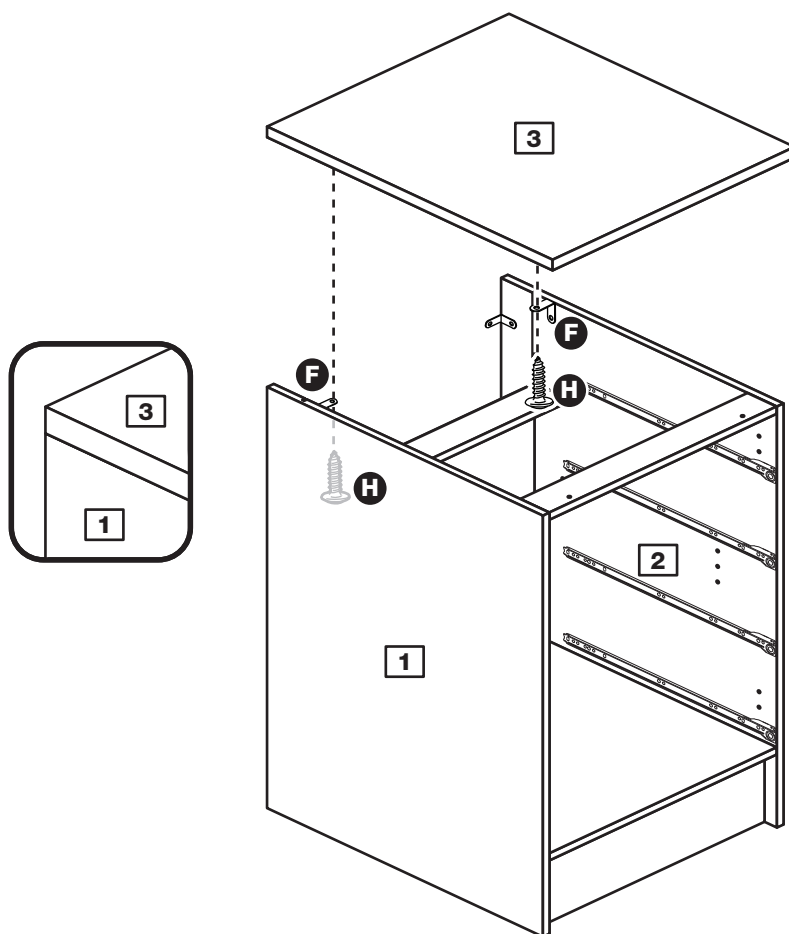

Step 21

Secure the front of the top

To secure the front of the top **3**, screw up through the 2 holes in the rail **5** at the front of the unit using screws **G**.

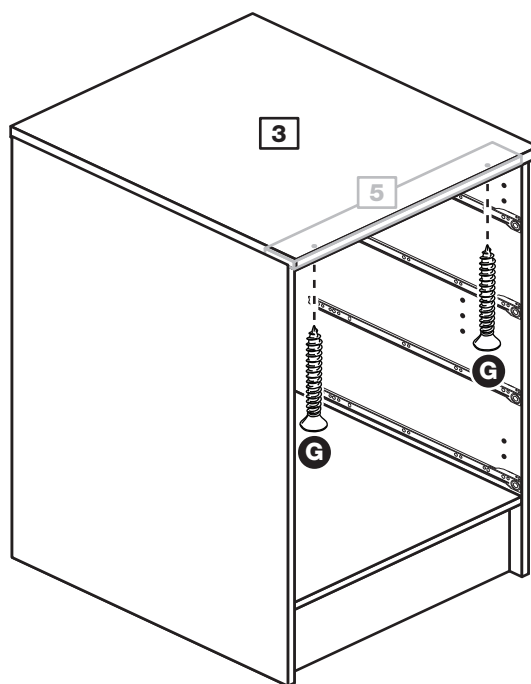

Assembly Instructions

Step 22

Secure the unit to the wall

Using the brackets **F** fitted to the back edge of the sides **1** and **2** screw the unit to the wall.

Fixings are not supplied as they will need to suit the wall type, and the length of screw will depend on the distance of the back of the Unit to the wall.



Warning: Take care when drilling the wall that you do not drill into any pipes, wires etc. If in doubt, consult an expert.

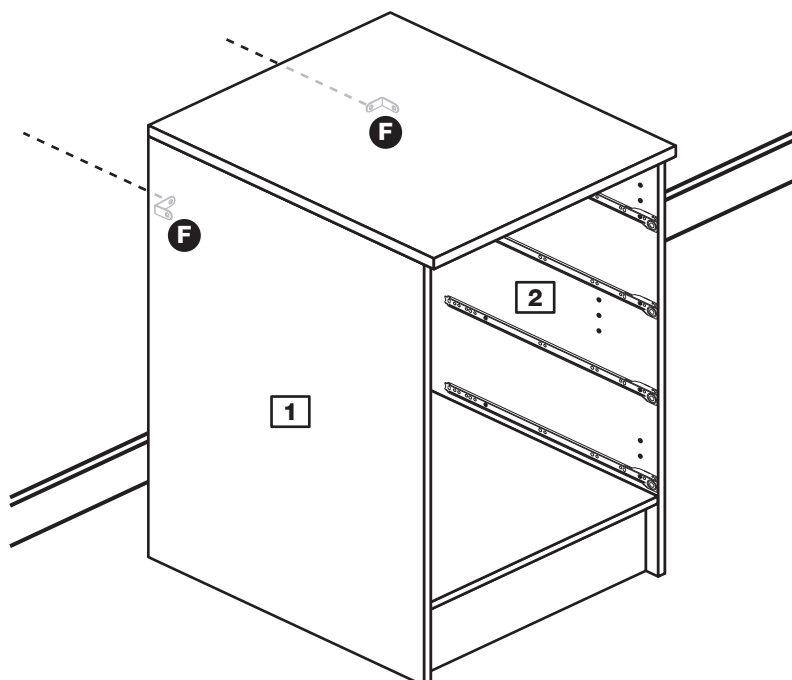

Step 23

Fit the drawers

Slide the wheels on the runners fitted to the drawer sides over the wheels on the runners fitted to the side panels and push the drawer into position.

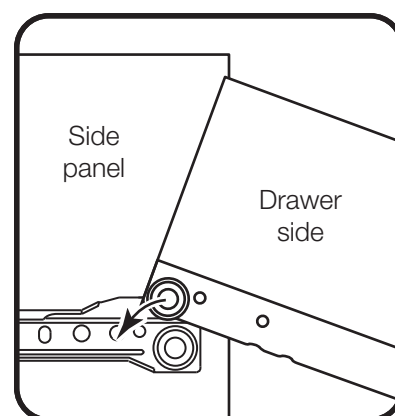
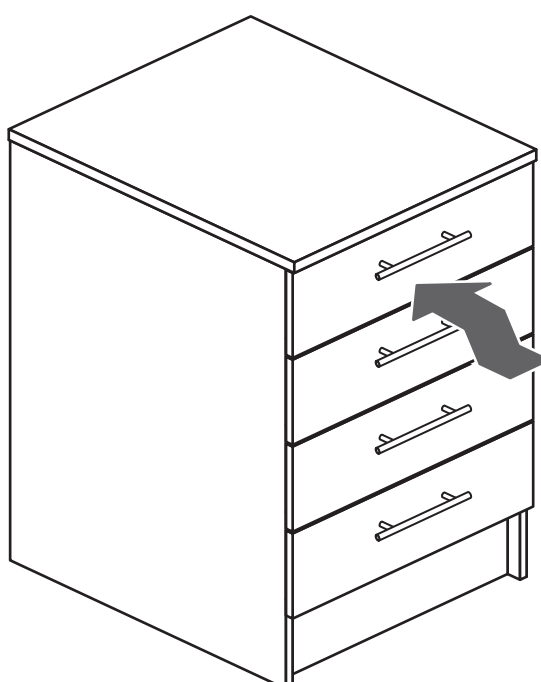

Assembly Instructions

Step 24

Assembly is complete



Warning: The unit is heavy. Lift with care.

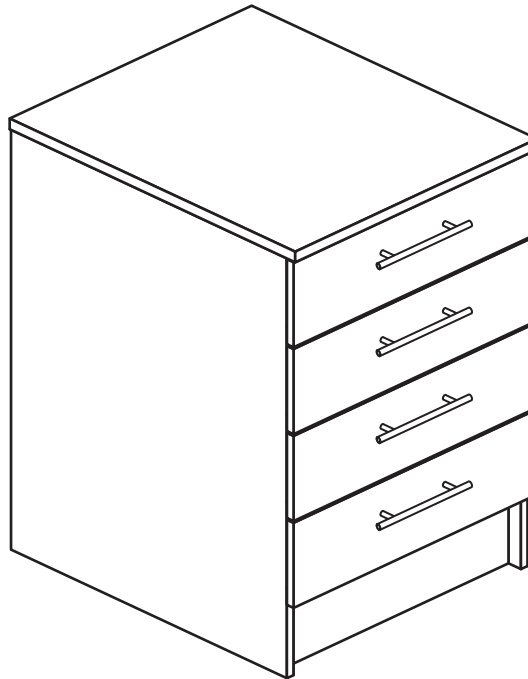

If you need help or have damaged or missing parts, call the **Customer Helpline: 08456 400800** and quote the reference numbers on the component pages.

Argos Ltd, 489-499 Avebury Boulevard, Central Milton Keynes, MK9 2NW

Athina - 500 Drawer Unit

Assembly Instructions - Please keep for future reference

608/0804

608/0921

608/0866

608/0983

608/2974



Dimensions

Width - 50cm

Depth - 59cm

Height - 89.5cm



**MADE IN
BRITAIN**

Important - Please read these instructions fully before starting assembly

If you need help or have damaged or missing parts, call the **Customer Helpline: 03456 400800**



Safety and Care Advice

Important - Please read these instructions fully before starting assembly

- **Warning:** This unit weighs approximately 34kgs. Please lift with care.

- Check you have all the components and tools listed on pages 2 and 3.

- Remove all fittings from the plastic bags and separate them into their groups.

- Keep children and animals away from the work area, small parts could choke if swallowed.

- Make sure you have enough space to layout the parts before starting.

- Do not stand or put weight on the product, this could cause damage.

- Assemble the item as close to its final position (in the same room) as possible.

- Assemble on a soft level surface to avoid damaging the unit or your floor (use opened out unit carton).



- We do not recommend the use of power drill/drivers **for inserting screws**, as this could damage the unit. Only use hand screwdrivers.

- **Safety note:** It is recommended that this unit is secured to a wall using the brackets supplied.

- Dispose of all packaging carefully and responsibly.

Care and maintenance

- Only clean using a damp cloth and mild detergent, do not use bleach or abrasive cleaners.

- From time to time check that there are no loose screws on this unit.

- This product should not be discarded with household waste. Take to your local authority waste disposal centre.

Note: If required the next page can be cut out and used as reference throughout the assembly. Keep this page with these instructions for future reference.

Components - Panels

If you have damaged or missing components, call the **Customer Helpline: 03456 400800** quoting the reference numbers below

Please check you have all the panels listed below

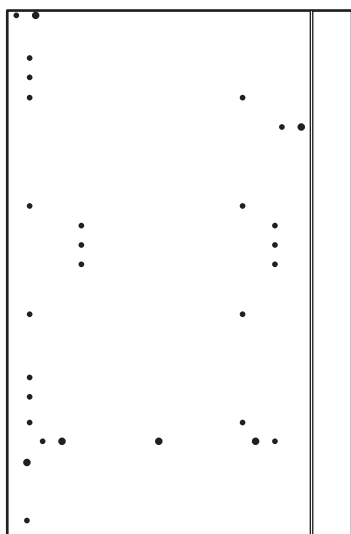

1 Left Side (D0315B)
(870 X 570mm)

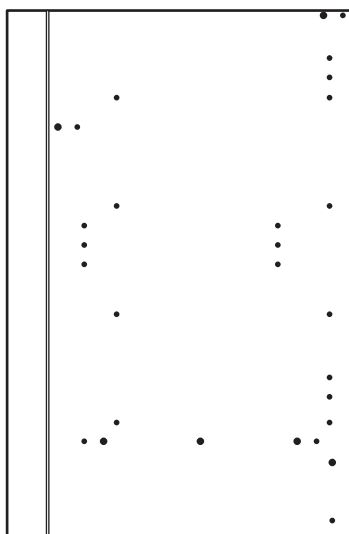

2 Right Side (D0316B)
(870 x 570mm)

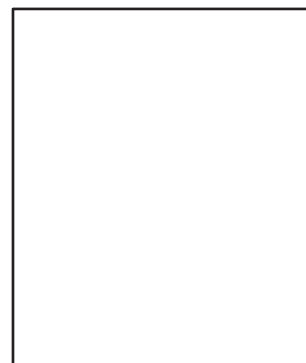

3 Top (D0338A)
(500 x 590mm)

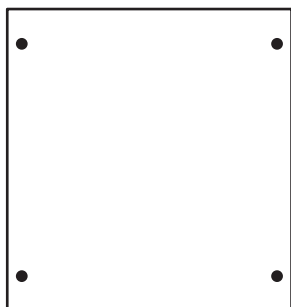

4 Base (D0319A)
(470 X 499mm)

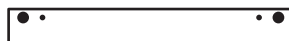

5 Rail (D0321A)
(470 x 60mm) x 2

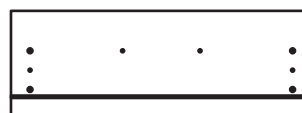

7 Drawer Front (D0318A)
(497 x 176mm) x 4



6 Plinth (D0322A)
(470 x 150mm)



8 Drawer Back (W422-120)
(422 x 120mm) x 4



9 Left Drawer Side (W450-120LH)
(450 x 120mm) x 4



11 Drawer Base (T413)
(447 x 433mm) x 4

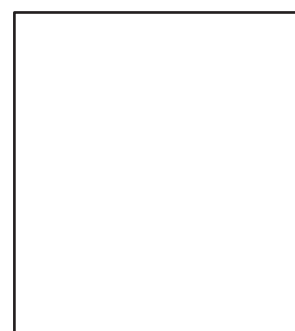

12 Back (X739)
(480 x 533mm)



10 Right Drawer Side (W450-120RH)
(450 x 120mm) x 4











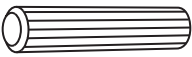
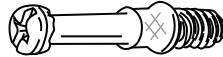

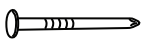
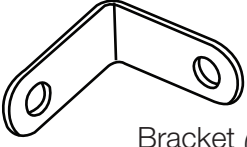

Components - Fittings

If you have damaged or missing components, call the **Customer Helpline: 03456 400800** quoting the reference numbers below

Please check you have all the fittings listed below

Note: The quantities below are the correct amount to complete the assembly. In some cases more fittings may be supplied than are required.

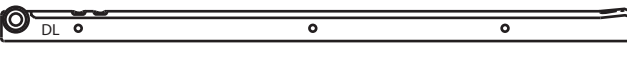
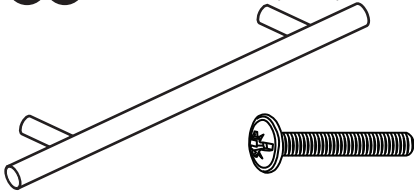
| | | |
|---|--|---|
| <p>A </p> <p>Wooden dowel (F22) x 12</p> | <p>B </p> <p>Metal dowel (F901) x 18</p> | <p>C </p> <p>Large locking nut (F900) x 10</p> |
| <p>D </p> <p>Small locking nut (F3) x 8</p> | <p>E </p> <p>Nail (F51) x 8</p> | <p>F </p> <p>Bracket (F945) x 4</p> |
| <p>G </p> <p>25mm Screw (F50) x 2</p> | <p>H </p> <p>13mm Screw (F79) x 6</p> | <p>I </p> <p>13mm Screw (F63) x 16</p> |
| <p>J </p> <p>Door Buffer (F137) x 8</p> | <p>K </p> <p>Knock-in Peg (F171GY) x 16</p> | <p>L </p> <p>13mm Screw (F52) x 16</p> |
| <p>M a  CR Runner (F133) x 4</p> <p>M b  CL Runner (F134) x 4</p> <p>M c  DR Runner (F135) x 4</p> <p>M d  DL Runner (F136) x 4</p> | | <p>N a Handle (F847a) x 4</p> <p>N b Handle Screw (F847b) x 8</p>  |

Tools required

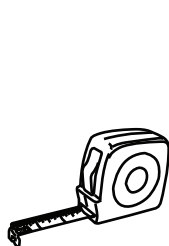

Rule



Scissors



Cross-head screwdriver



Hammer



Eye protection (when using a hammer or drill)



Electric drill

Ruler - Use this ruler to help correctly identify the screws

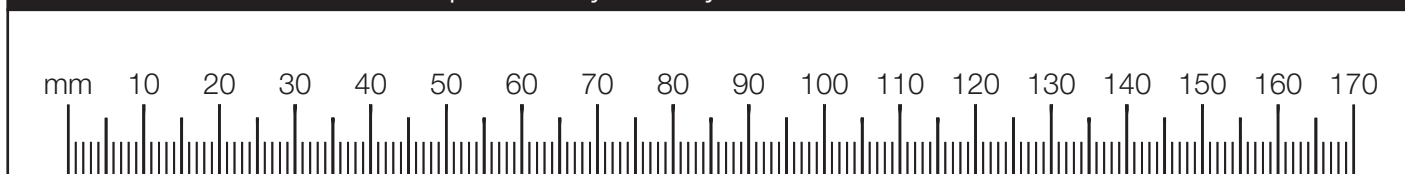

Assembly Instructions

If you have damaged or missing components, call the Customer Helpline: 03456 400800 quoting the reference numbers below

Step 1

Prepare 4 drawer fronts

Screw 2 metal dowels **B** into the holes shown on the back of each drawer front **7**.

Note: Tighten metal dowels up fully against the panels.

Stick a drawer buffer **J** into the top corners of each drawer front **7**.

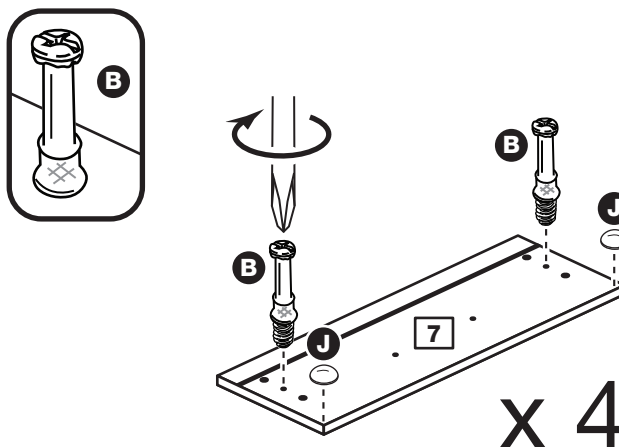

Step 2

Prepare the drawer sides

Insert a small locking nut **D** into the hole shown on the left drawer side **9** and right drawer side **10**.

Note: The arrow on the locking nut **must** point towards the hole in the edge of the panel.

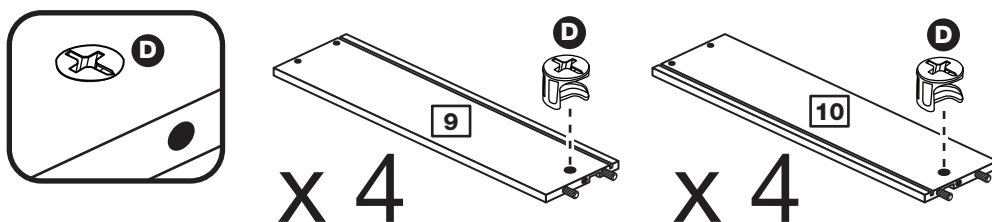

Step 3

Attach the drawer sides to the drawer fronts

Push the left drawer side **9** and right drawer side **10** onto the back of the drawer front **7**.

Turn the small locking nuts **D** on the left drawer side **9** and right drawer side **10**.

Note: Turn the locking nuts **D** clockwise to secure panels - more than 1/2 a turn.

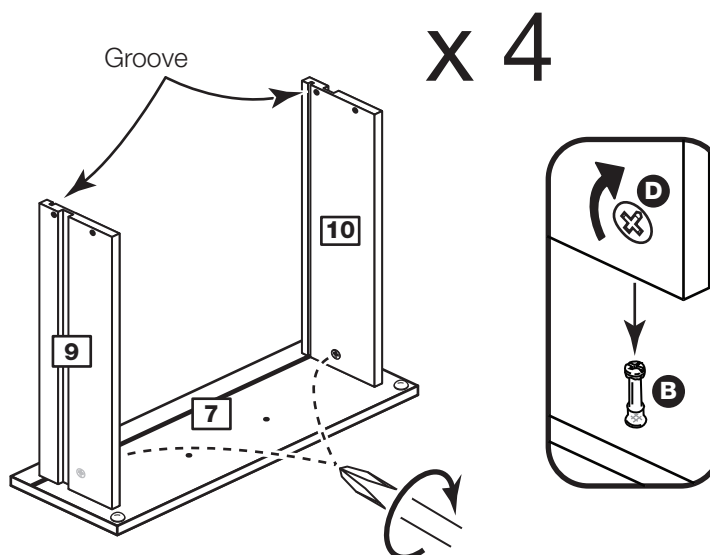

Assembly Instructions

Step 4

Fit the drawer bases

Slide the drawer base **11** down the grooves in the drawer sides **9** and **10** and down into the groove in the drawer front **7**.

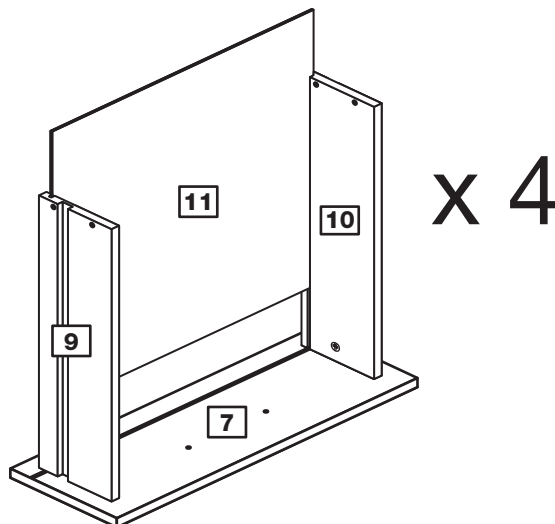

Step 5

Fit the drawer backs

Fit the drawer back **8** between the drawer sides **9** and **10**.

Make sure that the drawer base **11** fits into the groove in the drawer back **8**.

Hold the drawer back **8** in position and tap the knock-in pegs **K** through the holes in the drawer sides **9** and **10**.

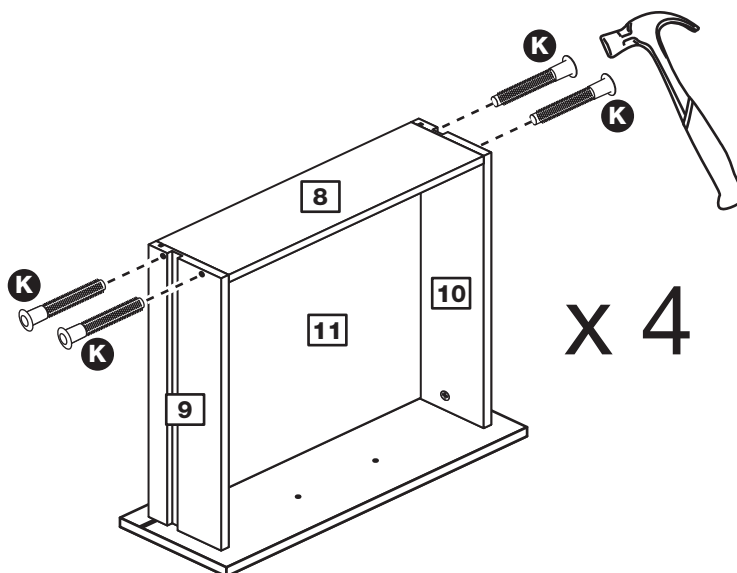

Step 6

Attach the handles

Attach a handle **Na** to each drawer front **7** using 2 screws **Nb**.

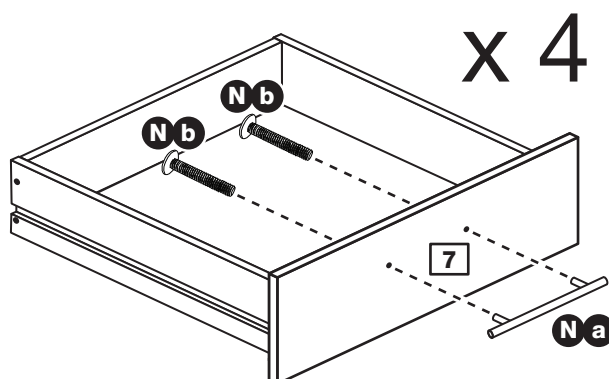

Assembly Instructions

Step 7

Fit runners to the drawers

Turn the 4 drawer assemblies over.

Fit runner **Mc**, marked with 'DR', to the bottom edge of the right drawer side **10**, making sure that it is pushed up against the back of the drawer front **7**. Use a bradawl to mark the fixing positions, then secure with 2 screws **I**.

Fit runner **Md**, marked 'DL', to the bottom edge of the left drawer side **9** using the same method.

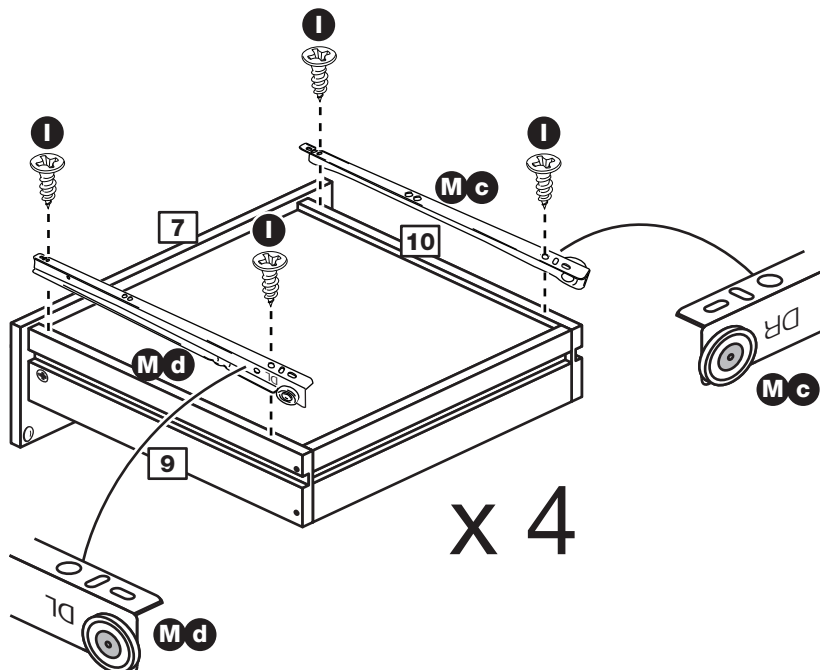

Assembly Instructions

Step 8

Fit 2 brackets to the left side

Fit a bracket **F** to the left side **1**, 100mm in from the back edge, see diagram.

Fit another bracket **F** to the left side **1**, 100mm down from the top edge, see diagram.

Secure each bracket using screw **H**.

Note: The brackets must be flush with the edges of the panel.

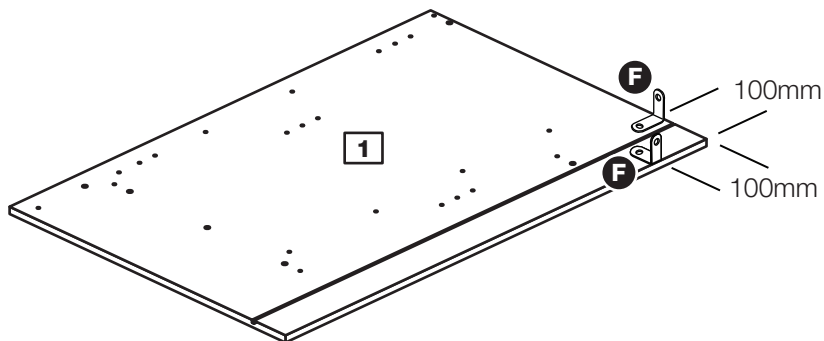
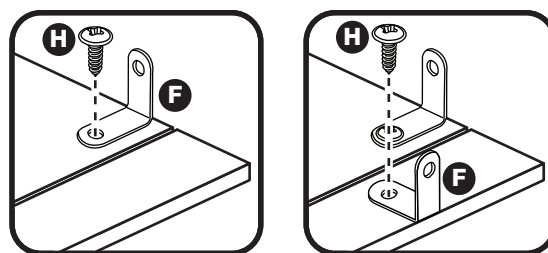

Step 9

Fit runners to the left side

Fit the 4 runners **M b** marked 'CL' to the left side **1**.

The 1st screw **L** uses the 2nd hole in from the front of the runner.

The 2nd screw **L** uses the 4th hole in from the back of the runner.

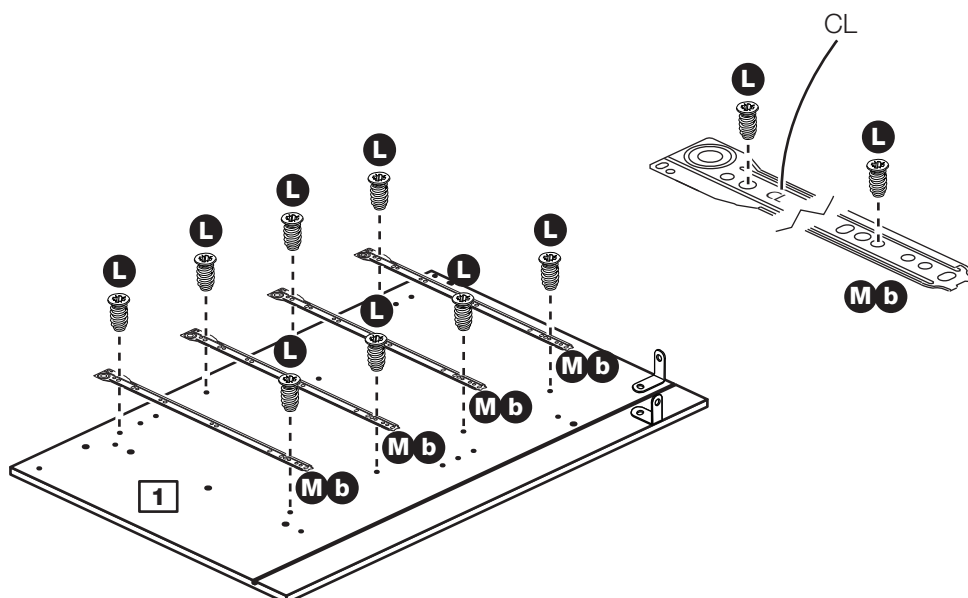

Step 10

Fit metal dowels to the left side

Screw 5 metal dowels **B** into the holes shown on the left side **1**.

Note: Tighten metal dowels up fully against the panels.

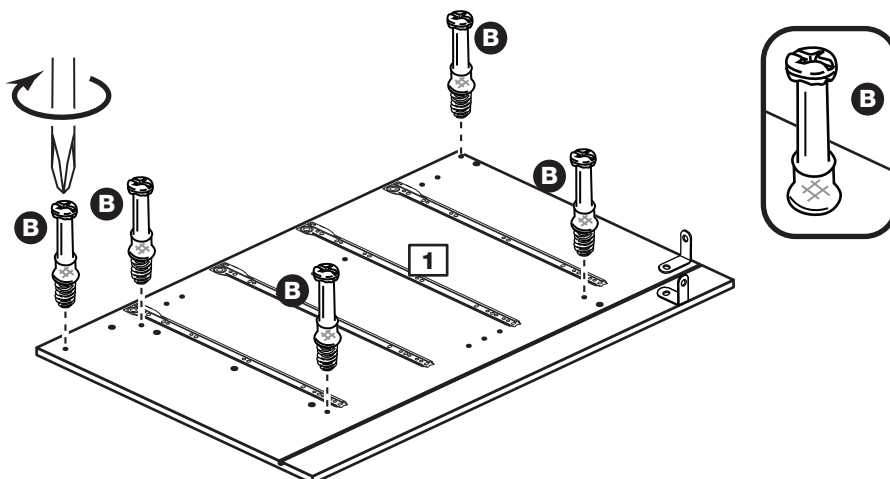

Assembly Instructions

Step 11

Fit 2 brackets to the right side

Fit a bracket **F** to the right side **2**, 100mm down from the back edge, see diagram.

Fit another bracket **F** to the right side **2**, 100mm down from the top edge, see diagram.

Secure each bracket using screw **H**.

Note: The brackets must be flush with the edges of the panel.

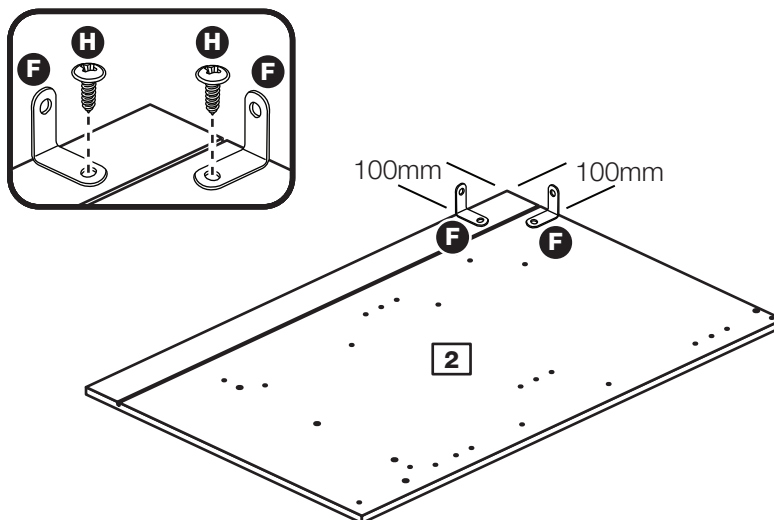

Step 12

Fit runners to the right side

Fit the 4 runners **Ma** marked 'CR' to the right side **2**.

The 1st screw **L** uses the 2nd hole in from the front of the runner.

The 2nd screw **L** uses the 4th hole in from the back of the runner.

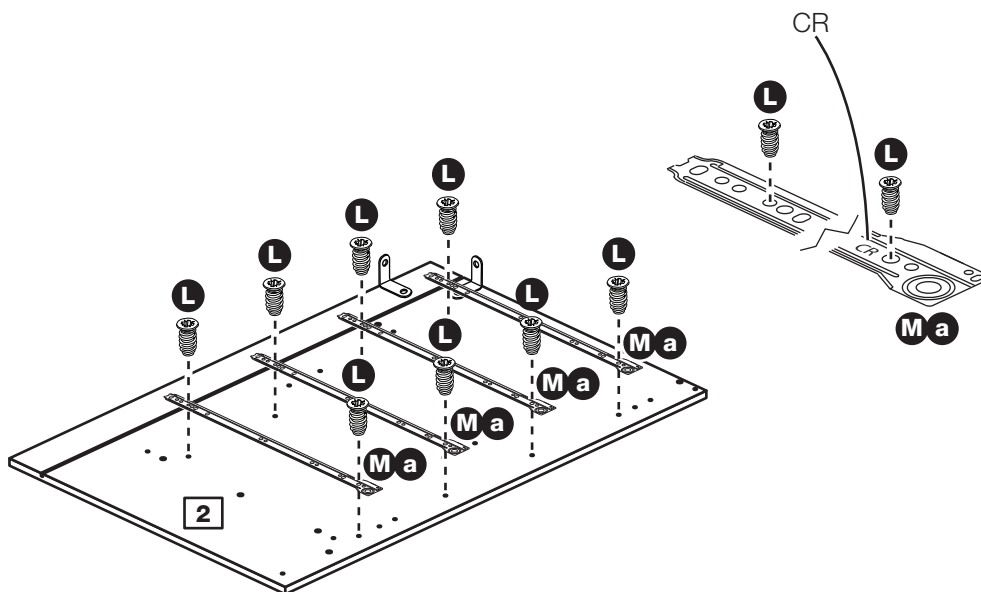

Step 13

Fit metal dowels to the right side

Screw 5 metal dowels **B** into the holes shown on the right side **2**.

Note: Tighten metal dowels up fully against

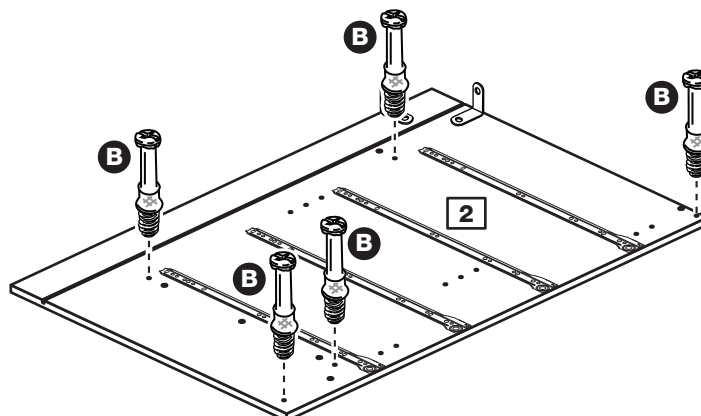

Assembly Instructions

Step 14

Prepare the base

Insert 4 large locking nuts **C** into the base **4** as shown.

Note: Arrow on locking nut **must** point towards hole in edge of panel.

Tap 6 wooden dowels **A** into the base **4** as shown.

Note: Wooden dowels **must not** stick out from the edge by more than 10mm or they may damage other panels.

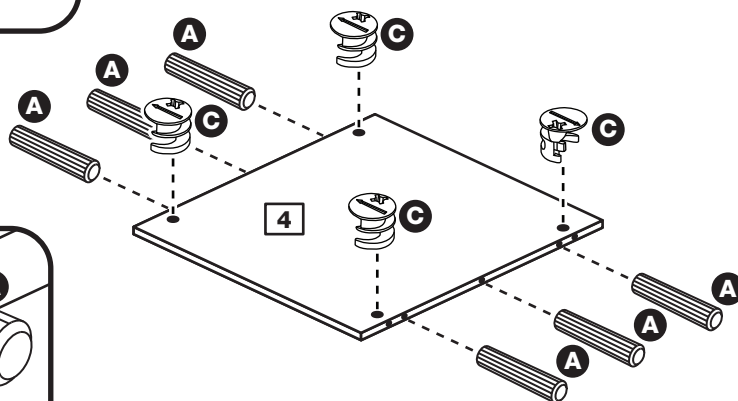
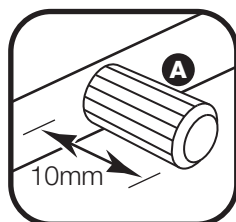
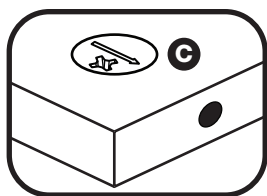

Step 15

Fit the base to the right side

Push the base **4** onto the right side **2**.

Use a screwdriver to tighten the 2 large locking nuts **C** fitted to the base **4**.

Note: Turn the large locking nuts **C** as far as they will go - more than 1/2 a turn.

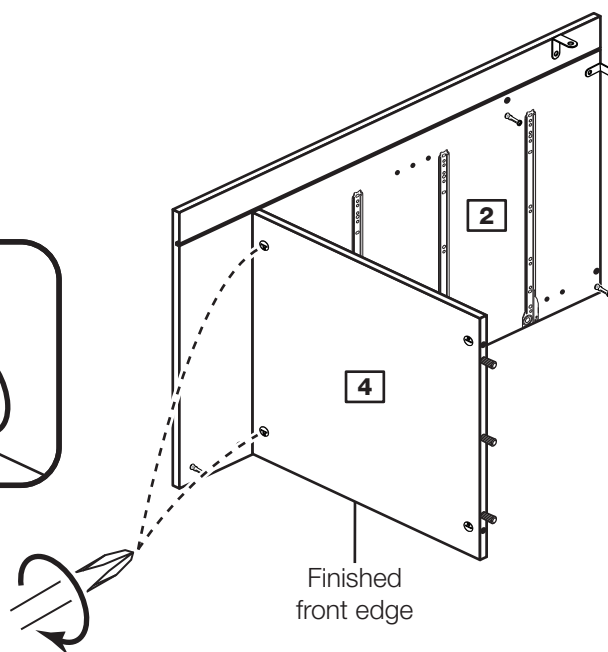
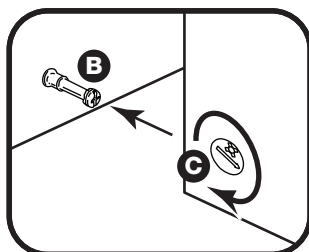

Step 16

Prepare the 2 rails and plinth

Insert 2 large locking nuts **C** into each of the 2 rails **5** and plinth **6** as shown.

Tap 2 wooden dowels **A** into the 2 rails **5** and plinth **6** as shown.

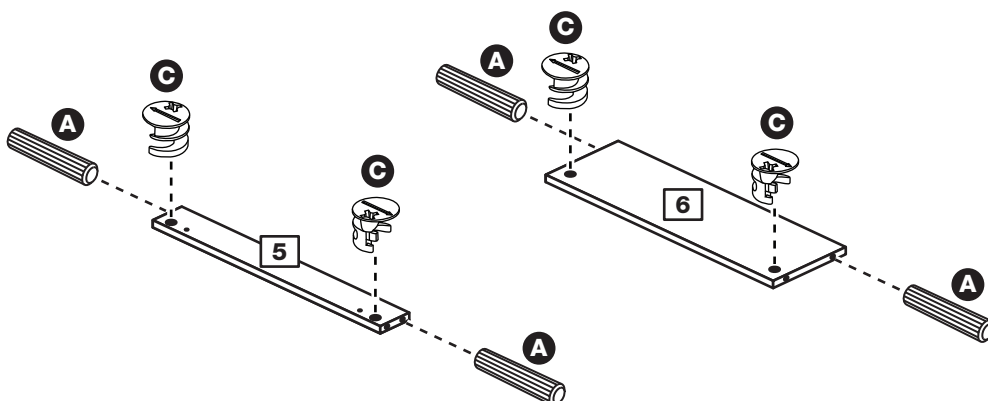

Assembly Instructions

Step 17

Fit the 2 rails and plinth

One at a time, push the 2 rails **5** and plinth **6** onto the right side **2** as shown.

Use a screwdriver to tighten the 3 large locking nuts **C** fitted to the 3 panels, as shown.

Note: Turn the large locking nuts **C** as far as they will go - more than 1/2 a turn.

Note: Support the rail near the back edge of the unit until the left side has been fitted in the next stage.

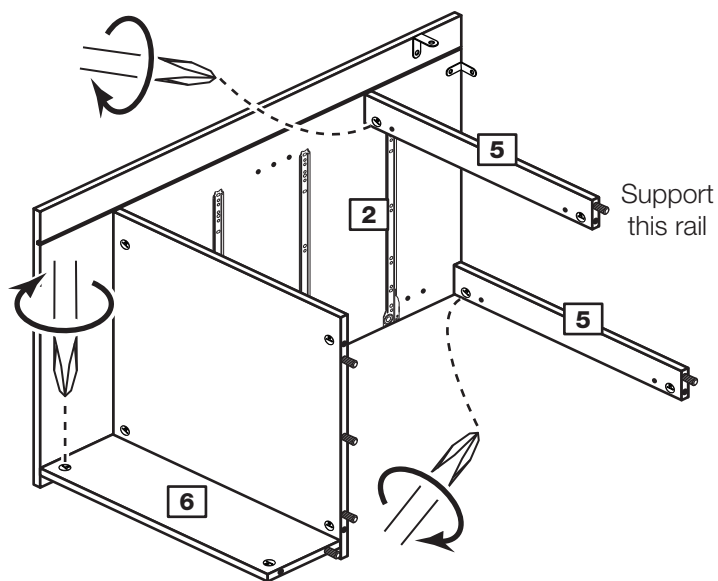

Step 18

Fit the left side

Push the left side **1** onto the assembly.

Use a screwdriver to tighten the 5 large locking nuts **C** fitted to the base **4**, rails **5** and plinth **6**.

Note: Turn the large locking nuts **C** as far as they will go - more than 1/2 a turn.

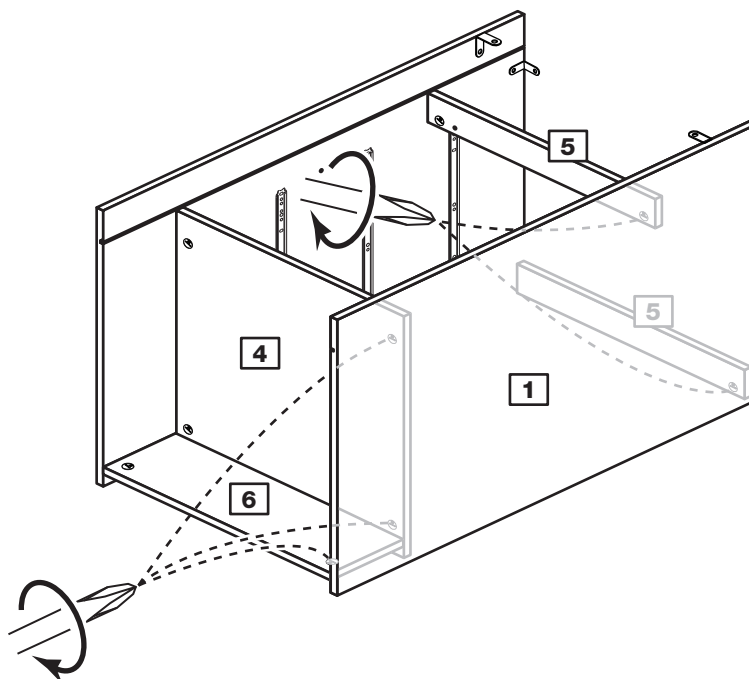

Assembly Instructions

Step 19

Fit the back

a: Square up the unit by making sure that measurement **x to x** equals **y to y**.

b: Slide the back **12** into the grooves along the left **1** and right **2** sides, as shown.

c: Secure the back **12** by tapping 4 nails **E** down into the back edge of the base **4** and 4 nails **E** into the back edge of the rail **5**.

Stand the unit up for the next stage.

a: The measurement from top corner X to bottom corner X must be equal to the measurement from top corner Y to bottom corner Y

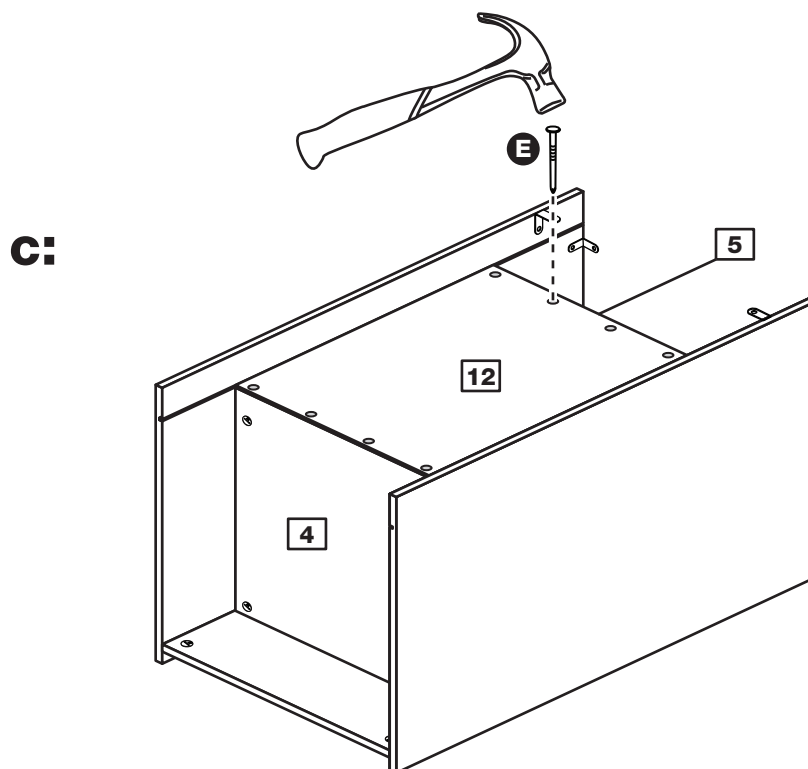
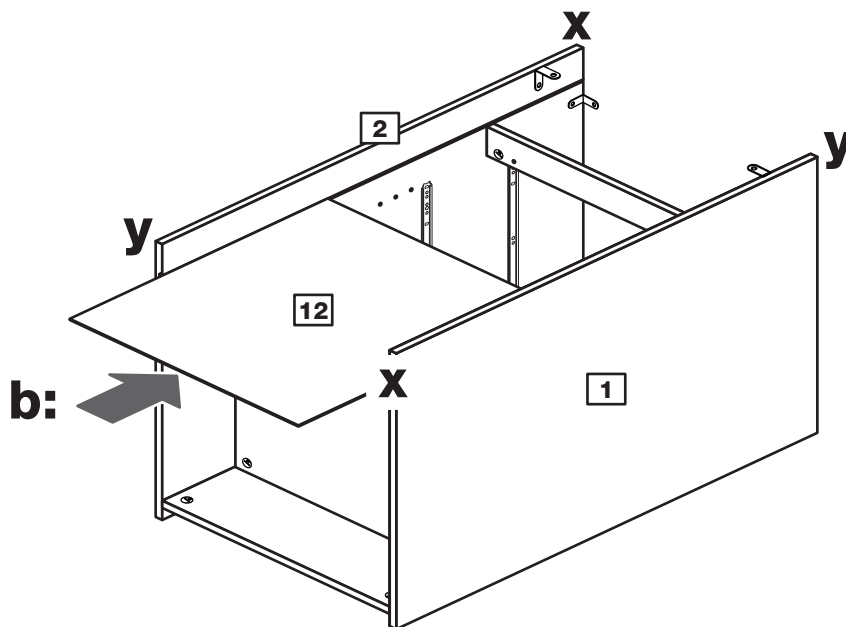

Assembly Instructions

Step 20

Fit the top

Position the top **3** onto the unit, making sure that the back edge is flush with the back edge of the sides **1** and **2**.

Secure the top **3** using screw **H** through the 2 brackets **F** fitted at the top edge of the side panels **1** and **2**.

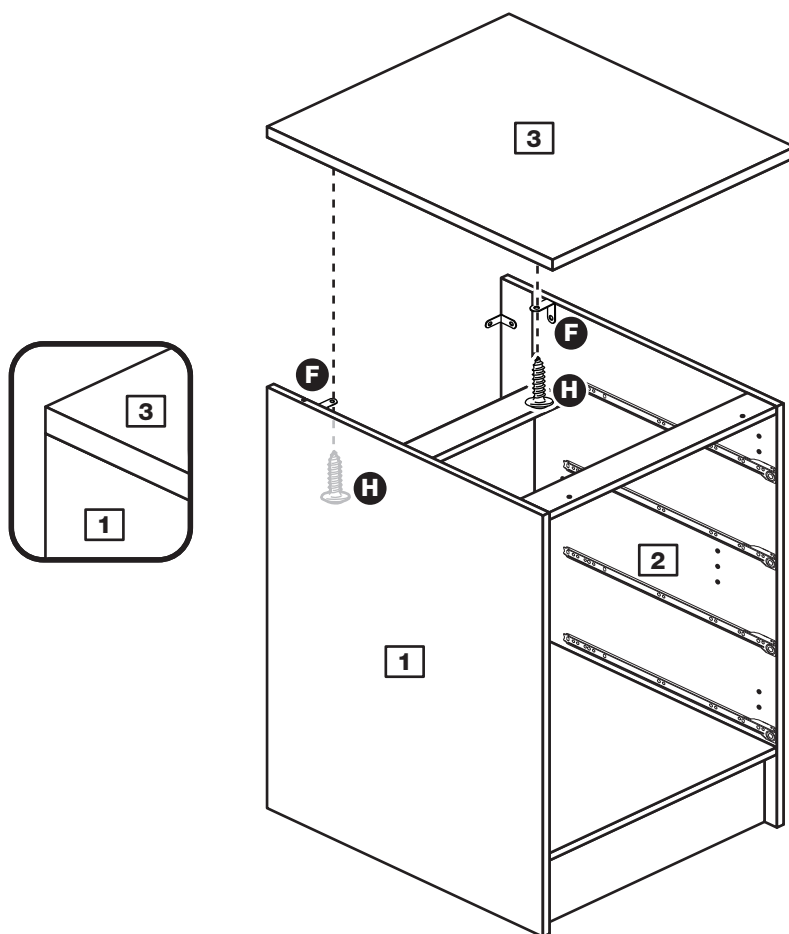

Step 21

Secure the front of the top

To secure the front of the top **3**, screw up through the 2 holes in the rail **5** at the front of the unit using screws **G**.

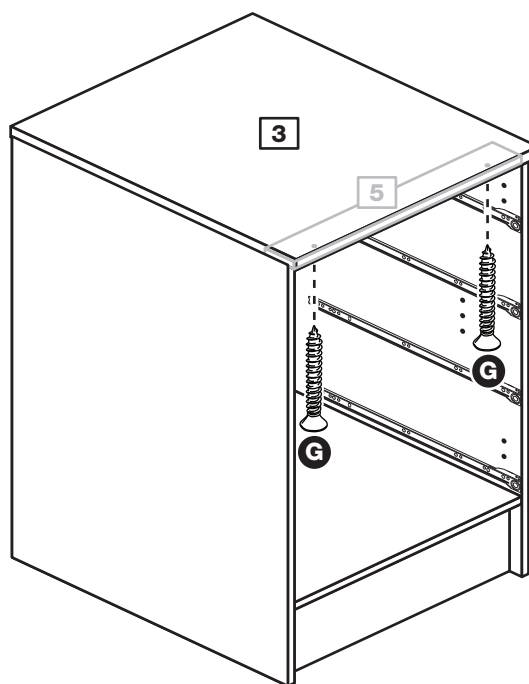

Assembly Instructions

Step 22

Secure the unit to the wall

Using the brackets **F** fitted to the back edge of the sides **1** and **2** screw the unit to the wall.

Fixings are not supplied as they will need to suit the wall type, and the length of screw will depend on the distance of the back of the Unit to the wall.



Warning: Take care when drilling the wall that you do not drill into any pipes, wires etc. If in doubt, consult an expert.

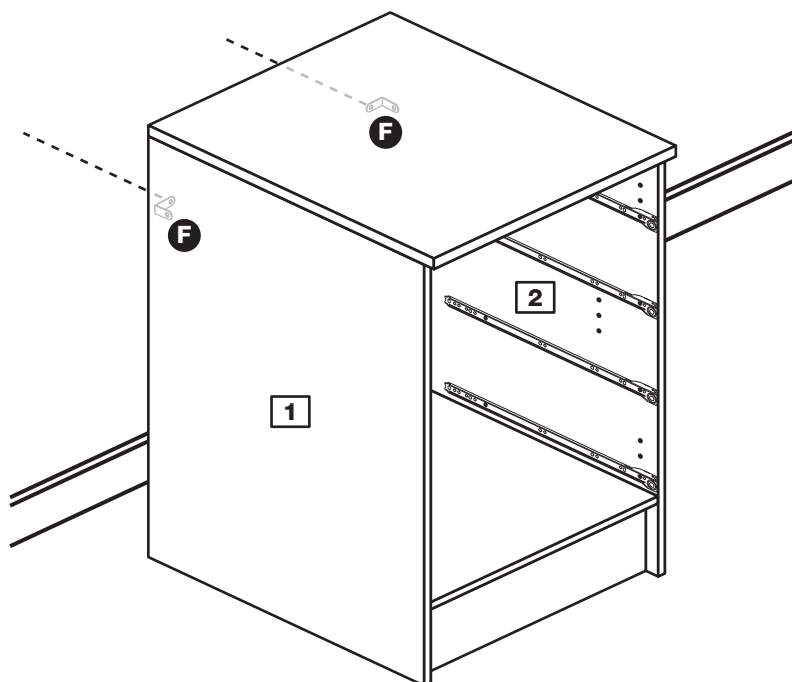

Step 23

Fit the drawers

Slide the wheels on the runners fitted to the drawer sides over the wheels on the runners fitted to the side panels and push the drawer into position.

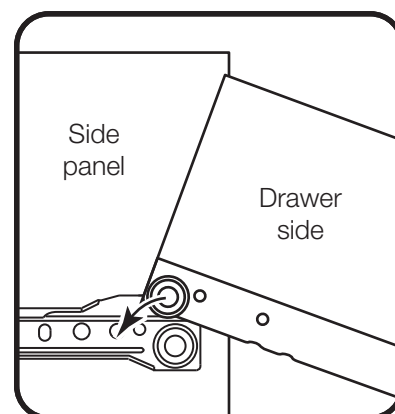
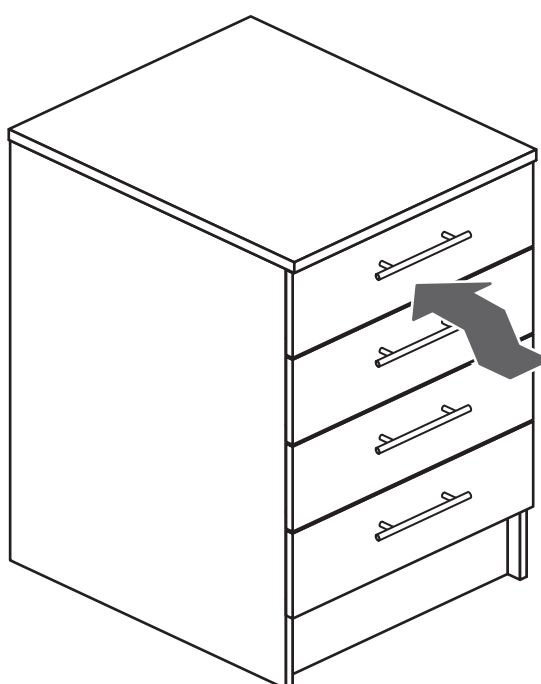

Assembly Instructions

Step 24

Assembly is complete



Warning: The unit is heavy. Lift with care.

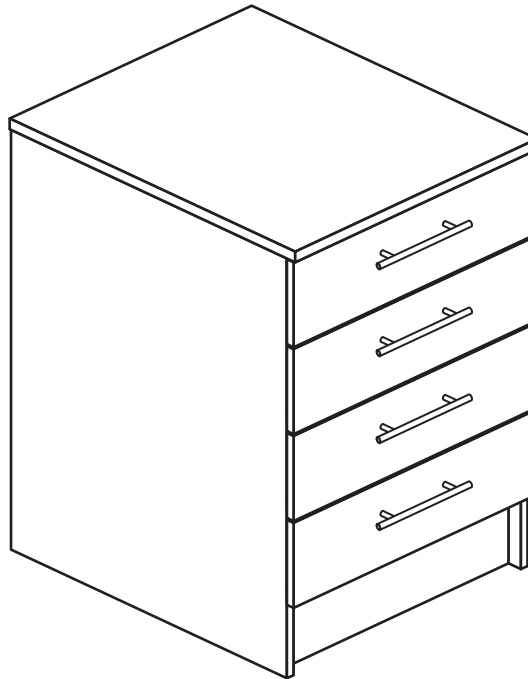

If you need help or have damaged or missing parts, call the **Customer Helpline: 03456 400800** and quote the reference numbers on the component pages.

Argos Ltd, 489-499 Avebury Boulevard, Central Milton Keynes, MK9 2NW

Athina - 500 Tall Cupboard

Assembly Instructions - Please keep for future reference

608/0794

608/0914

608/0859

608/0976

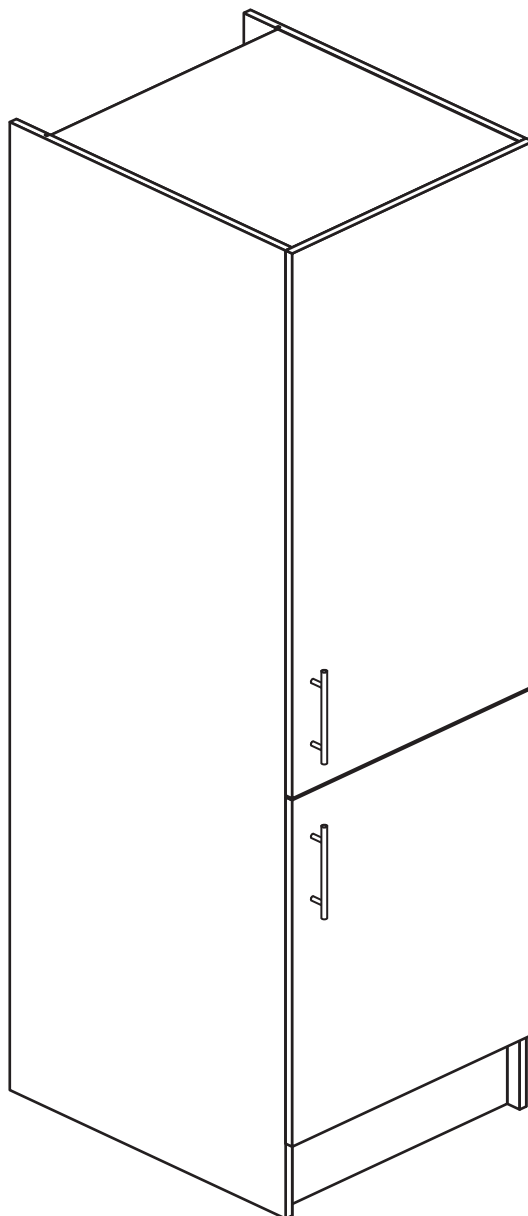

Dimensions

Width - 50cm

Depth - 59cm

Height - 200cm



**MADE IN
BRITAIN**

Important - Please read these instructions fully before starting assembly

If you need help or have damaged or missing parts, call the **Customer Helpline: 08456 400800**



Safety and Care Advice

Important - Please read these instructions fully before starting assembly

- **Warning:** This unit weighs approximately 51kgs. Please lift with care.

- Check you have all the components and tools listed on pages 2 and 3.

- Remove all fittings from the plastic bags and separate them into their groups.

- Keep children and animals away from the work area, small parts could choke if swallowed.

- Make sure you have enough space to layout the parts before starting.

- Do not stand or put weight on the product, this could cause damage.

- Assemble the item as close to its final position (in the same room) as possible.

- Assemble on a soft level surface to avoid damaging the unit or your floor (use opened out unit carton).



- We do not recommend the use of power drill/drivers **for inserting screws**, as this could damage the unit. Only use hand screwdrivers.

- **Safety note:** It is recommended that this unit is secured to a wall using the brackets supplied.

- Dispose of all packaging carefully and responsibly.

Care and maintenance

- Only clean using a damp cloth and mild detergent, do not use bleach or abrasive cleaners.

- From time to time check that there are no loose screws on this unit.

- This product should not be discarded with household waste. Take to your local authority waste disposal centre.

Note: If required the next page can be cut out and used as reference throughout the assembly. Keep this page with these instructions for future reference.

Components - Panels

If you have damaged or missing components, call the **Customer Helpline: 08456 400800** quoting the reference numbers below

Please check you have all the panels listed below

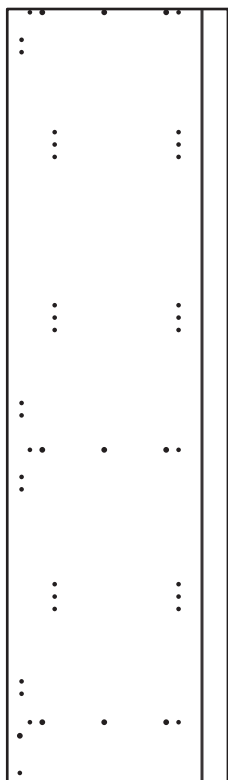

1 Left Side (D0328A)
(2000 X 570mm)

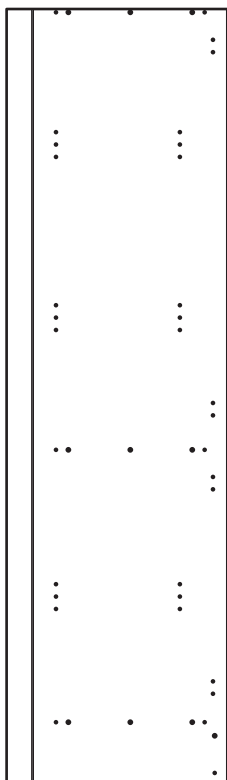

2 Right Side (D0329A)
(2000 X 570mm)

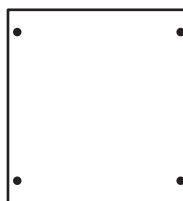

3 Horizontal (D0319A)
(470 X 499mm) x 3



4 Shelf (D0320A)
(469 x 427mm) x 2



5 Plinth (D0322A)
(470 x 150mm)

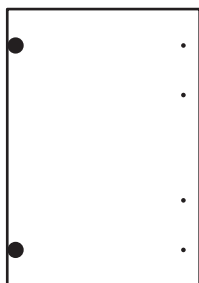

6 Small Door (D0317A)
(716 x 497mm)

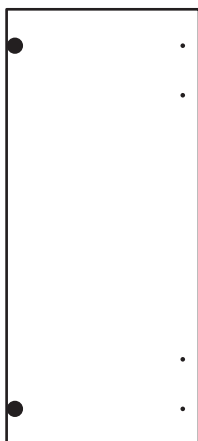

7 Large Door (D0330A)
(1126 x 497mm)

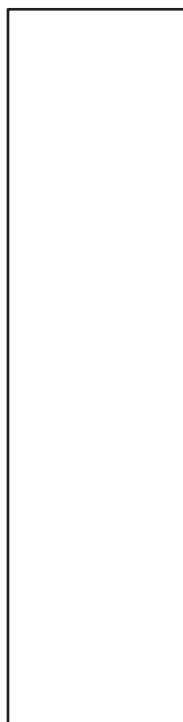

8 Back (X741)
(1848 x 480mm)











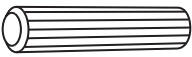
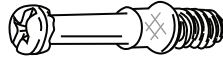

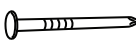
Components - Fittings

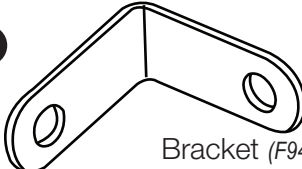
If you have damaged or missing components, call the **Customer Helpline: 08456 400800** quoting the reference numbers below

Please check you have all the fittings listed below

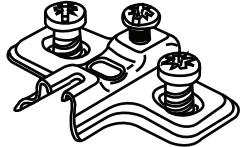
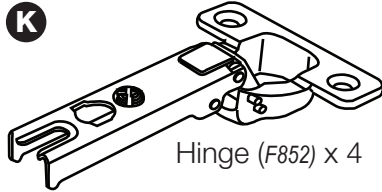
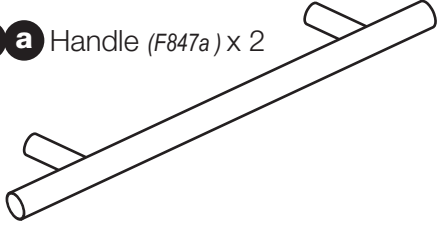
Note: The quantities below are the correct amount to complete the assembly. In some cases more fittings may be supplied than are required.

| | | |
|---|---|--|
| <p>A </p> <p>Wooden dowel (F22) x 20</p> | <p>B </p> <p>Metal dowel (F901) x 14</p> | <p>C </p> <p>Large locking nut (F900) x 14</p> |
| <p>D </p> <p>Nail (F51) x 8</p> | <p>E </p> <p>Shelf support (F110) x 8</p> | <p>F </p> <p>Bracket (F945) x 2</p> |
| <p>G </p> <p>Door Buffer (F137) x 4</p> | <p>H </p> <p>13mm Screw (F79) x 2</p> | <p>I </p> <p>13mm Screw (F63) x 8</p> |
| <p>J </p> <p>Hinge Plate (F853) x 4</p> | <p>K </p> <p>Hinge (F852) x 4</p> | |
| <p>L a  Handle (F847a) x 2</p> <p>L b  Handle Screw (F847b) x 4</p> | | |

Tools required

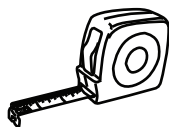

Rule



Cross-head screwdriver



Scissors



Hammer



Eye protection (when using a hammer or drill)



Electric drill

Ruler - Use this ruler to help correctly identify the screws

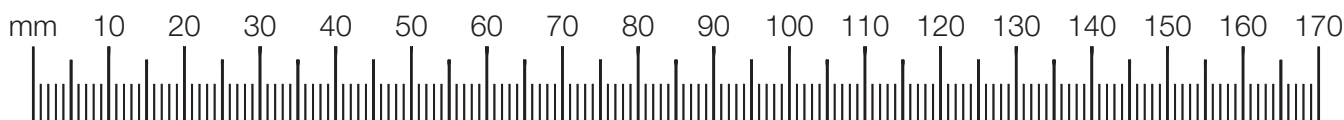

Assembly Instructions

If you have damaged or missing components, call the
Customer Helpline: 08456 400800 quoting the reference
numbers below

Step 1

Choose which way you would like the doors to open

You can fit the doors to the left side or right side.

If you would like your doors to open this way, fit the hinge plates to the left side

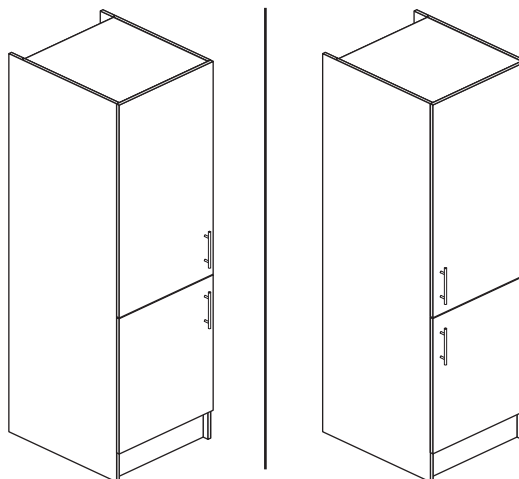

If you would like your doors to open this way, fit the hinge plates to the right side

Step 2

Fit a bracket to the left side

Fit a bracket **F** to the left side **1**, 10mm down from the top edge, see diagram.

Secure the bracket **F** using screw **H**.

Note: The bracket must be flush with the back edge of the panel.

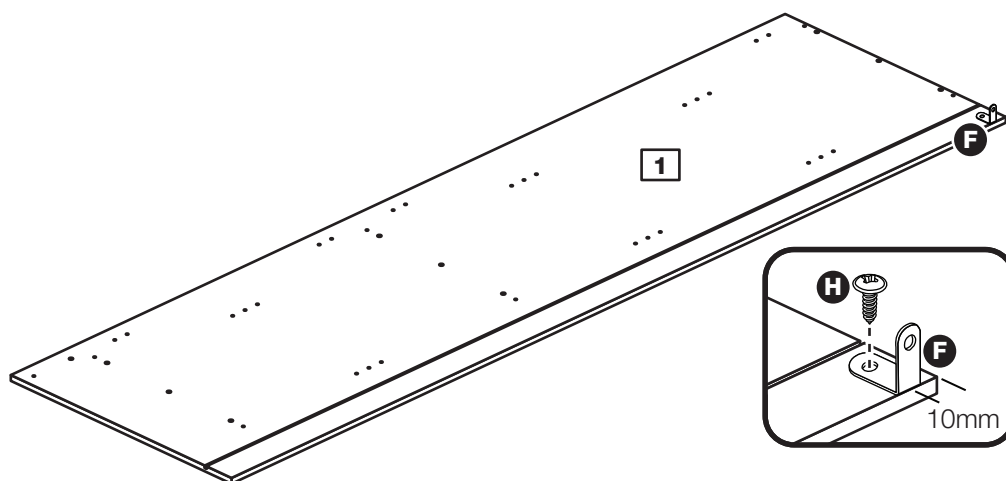

Step 3

Prepare the left side

a: Refer to step 1 and if required, fit 4 hinge plates **J** onto the left side **1**, making sure that the slot is facing towards the front edge.

b: Screw 7 metal dowels **B** into the holes shown on the left side **1**.

Note: Tighten metal dowels up fully against the panels.

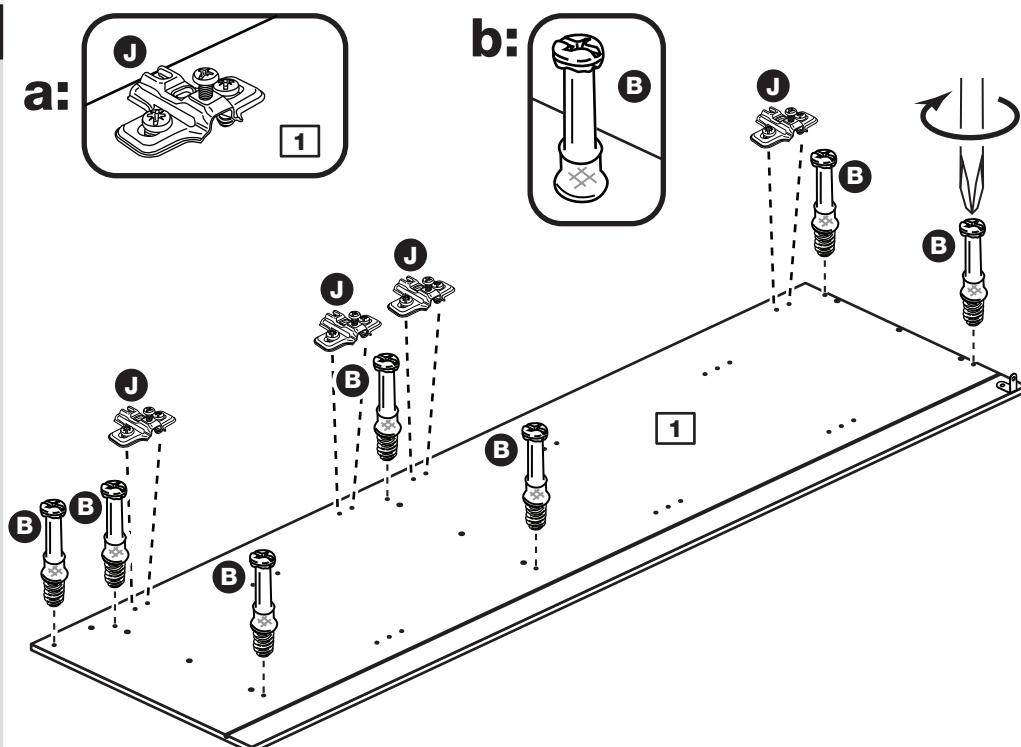

Assembly Instructions

Step 4

Fit 2 brackets to the right side

Fit a bracket **F** to the right side **2**, 10mm down from the top edge, see diagram.

Secure the bracket **F** using screw **H**.

Note: The bracket must be flush with the back edge of the panel.

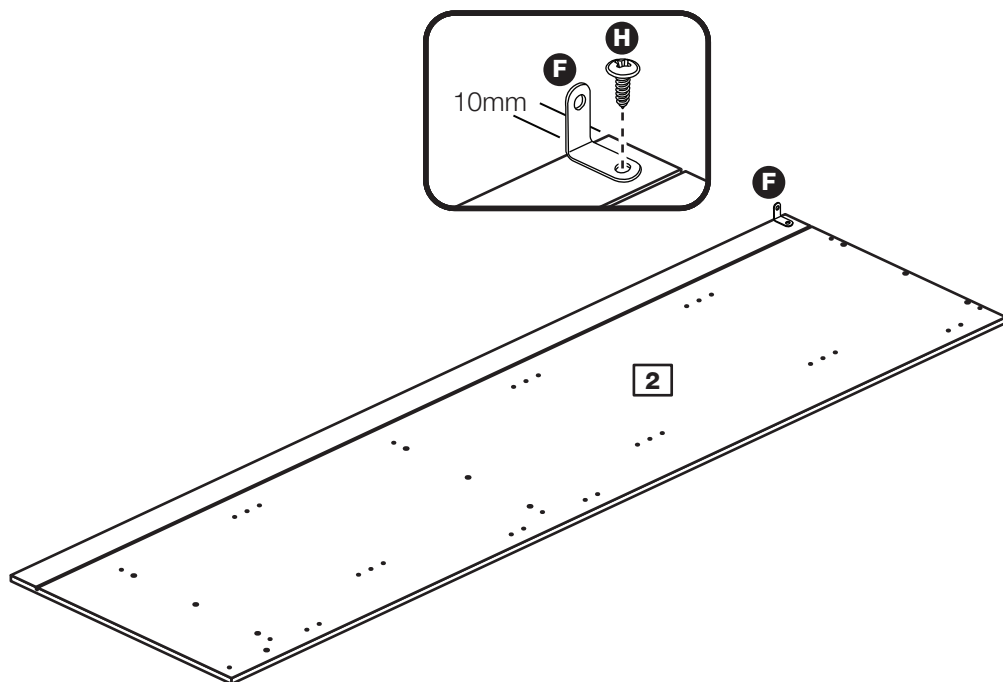

Step 5

Prepare the right side

a: Refer to step 1 and if required, fit 4 hinge plates **J** onto the right side **2**, making sure that the slot is facing towards the front edge.

b: Screw 7 metal dowels **B** into the holes shown on the right side **2**.

Note: Tighten metal dowels up fully against the panels.

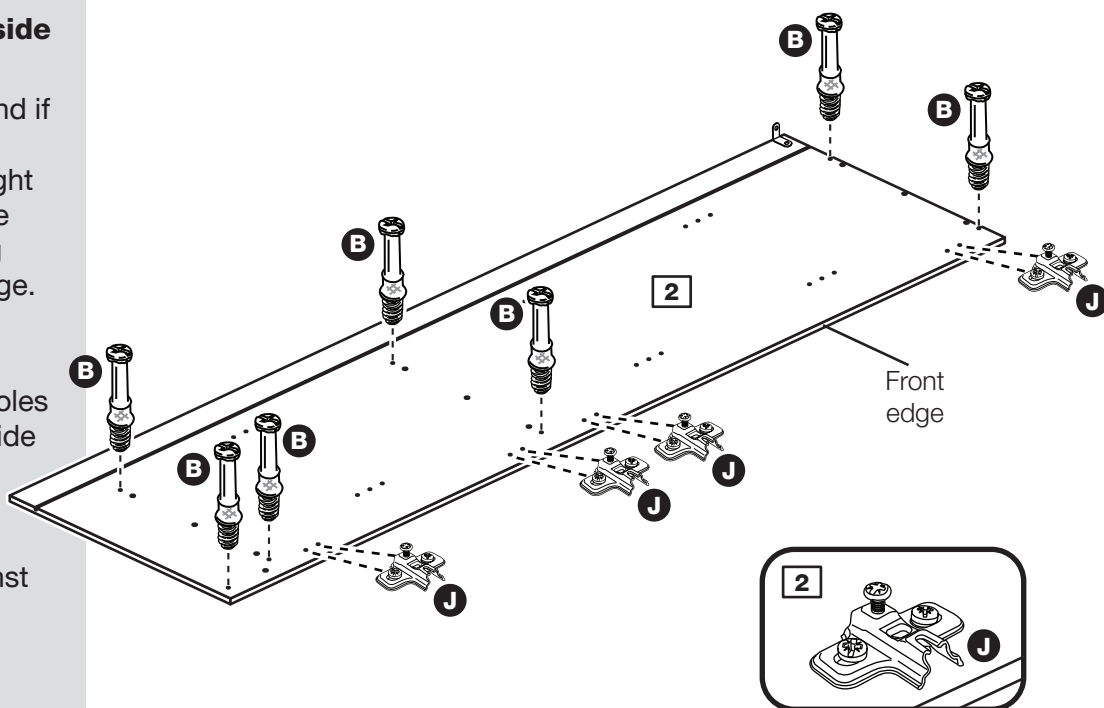

Assembly Instructions

Step 6

Prepare the 3 horizontals

Insert 4 large locking nuts **C** into each horizontal **3** as shown.

Note: Arrow on locking nut **must** point towards hole in edge of panel.

Tap 6 wooden dowels **A** into each horizontal **3** as shown.

Note: Wooden dowels **must not** stick out from the edge by more than 10mm or they may damage other panels.

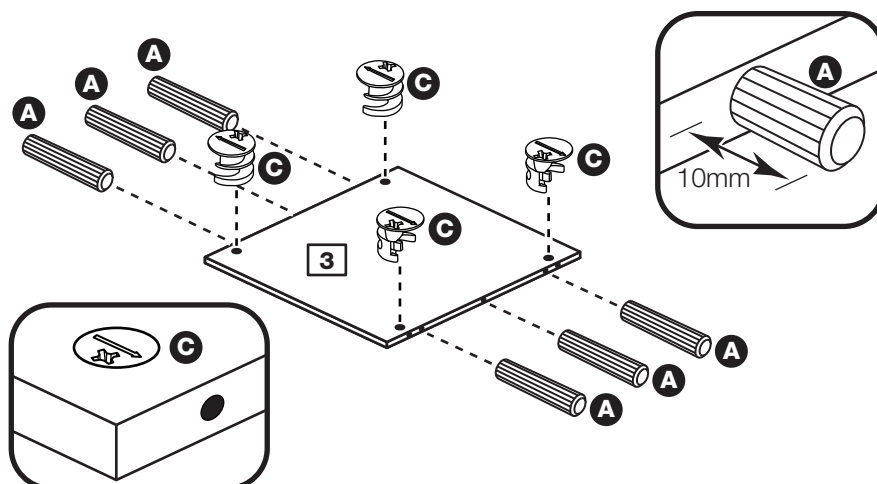

Step 7

Fit the 3 horizontals to the right side

Push the horizontals **3** onto the right side **2**.

Use a screwdriver to tighten the 2 large locking nuts **C** fitted to each horizontal **3**.

Note: Turn the large locking nuts **C** as far as they will go - more than 1/2 a turn.

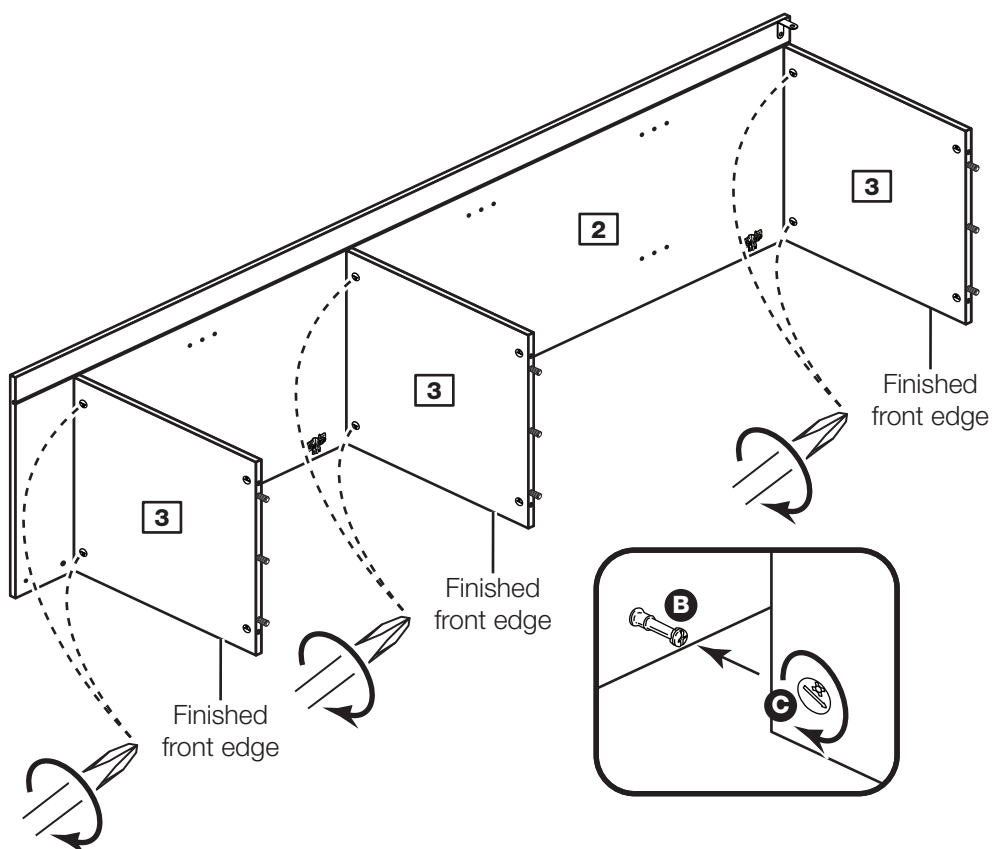

Step 8

Prepare the plinth

Insert 2 large locking nuts **C** into the plinth **5** as shown.

Tap 2 wooden dowels **A** into the plinth **5** as shown.

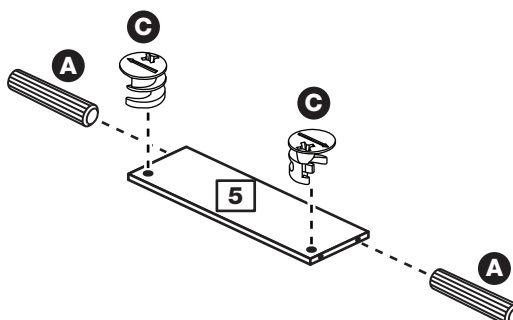

Assembly Instructions

Step 9

Fit the plinth to the right side

Push the plinth **5** onto the right side **2**, as shown.

Use a screwdriver to tighten the large locking nut **C** fitted to the plinth **5**, as shown.

Note: Turn the large locking nut **C** as far as they will go - more than 1/2 a turn.

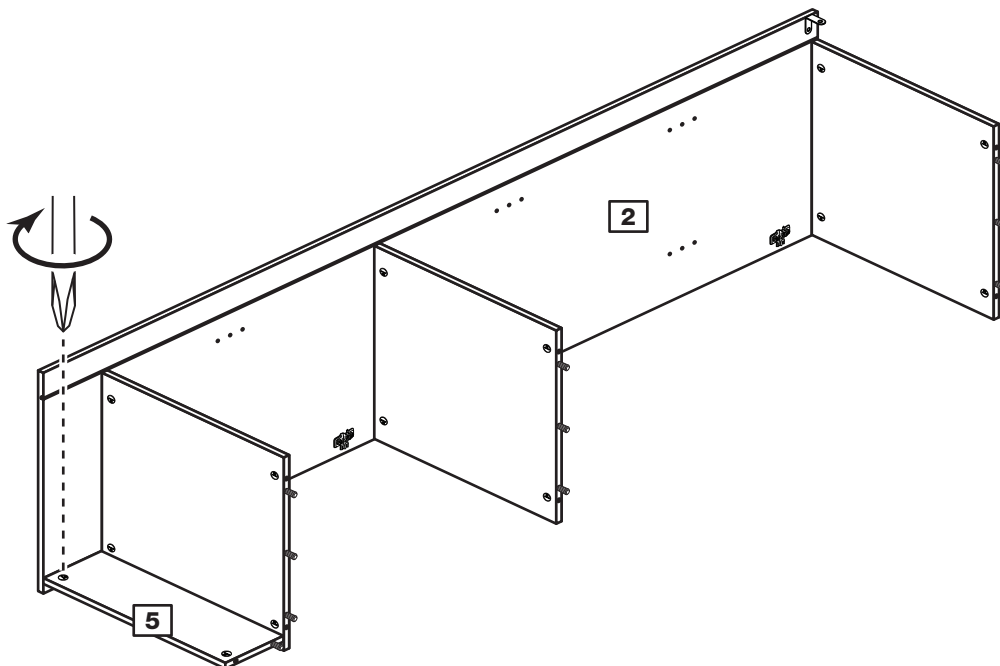

Step 10

Fit the left side

Push the left side **1** onto the assembly.

Use a screwdriver to tighten the 7 large locking nuts **C** fitted to the 3 horizontals **3** and plinth **5**.

Note: Turn the large locking nuts **C** as far as they will go - more than 1/2 a turn.

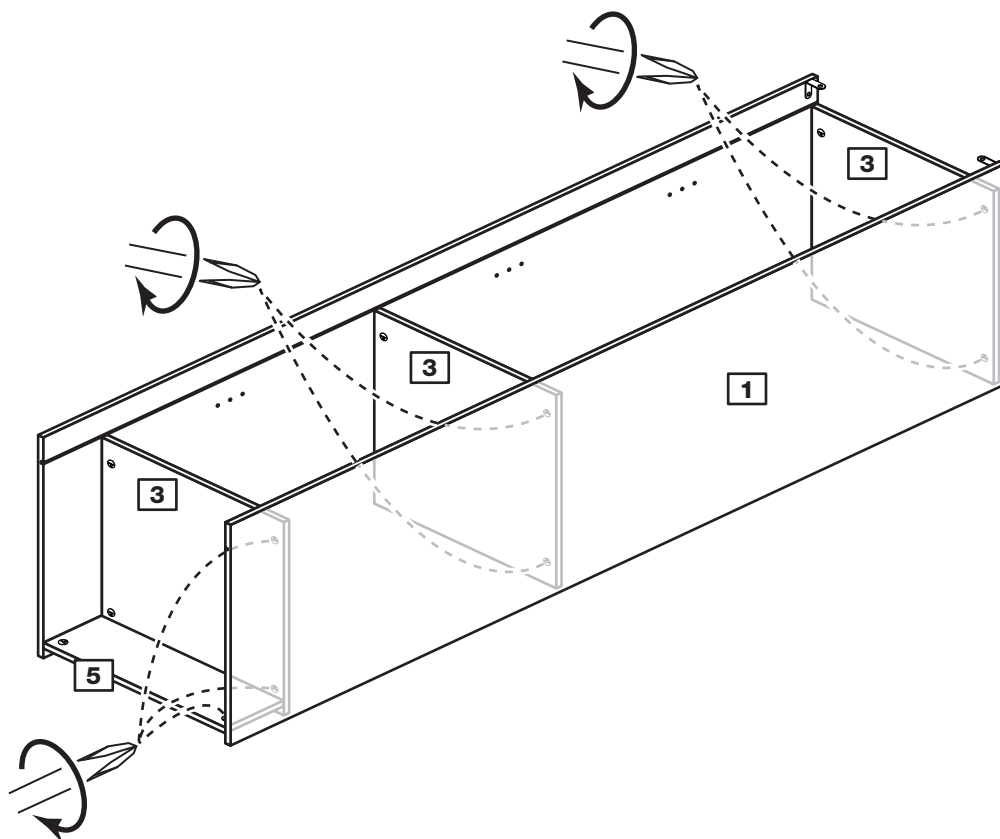

Assembly Instructions

Step 11

Fit the back

a: Square up the unit by making sure that measurement **x to x** equals **y to y**.

b: Slide the back **8** into the grooves along the left **1** and right **2** sides, as shown.

c: Secure the back **8** by tapping 4 nails **D** down into the back edge of the top horizontal **3** and 4 nails **D** into the back edge of the bottom horizontal **3**.

a: The measurement from top corner X to bottom corner X must be equal to the measurement from top corner Y to bottom corner Y

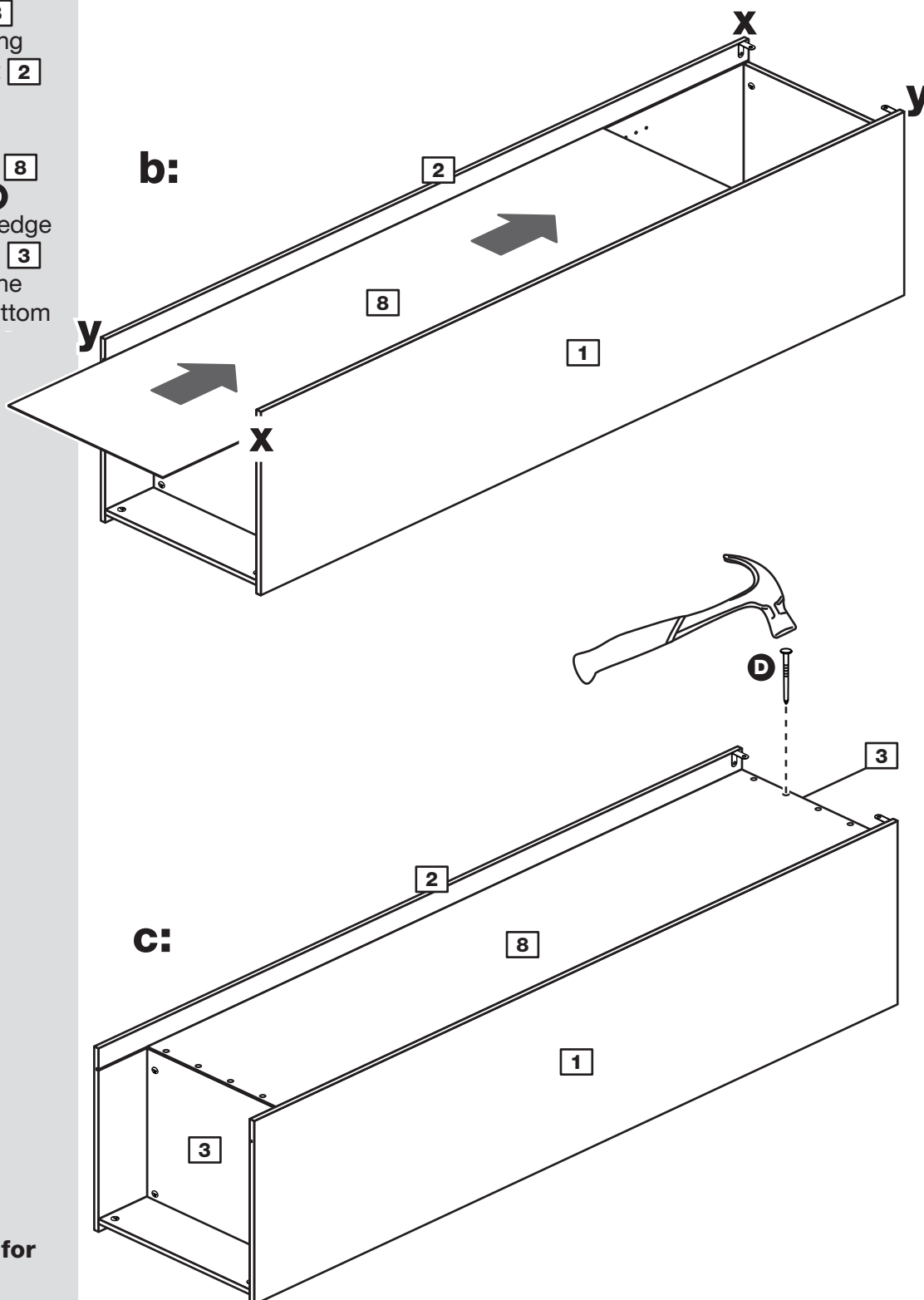

Stand the unit up for the next stage.

Assembly Instructions

Step 12

Secure the unit to the wall

Using the brackets **F** fitted to the back edge of the sides **1** and **2** screw the unit to the wall.

Fixings are not supplied as they will need to suit the wall type, and the length of screw will depend on the distance of the back of the Unit to the wall.



Warning: Take care when drilling the wall that you do not drill into any pipes, wires etc. If in doubt, consult an expert.

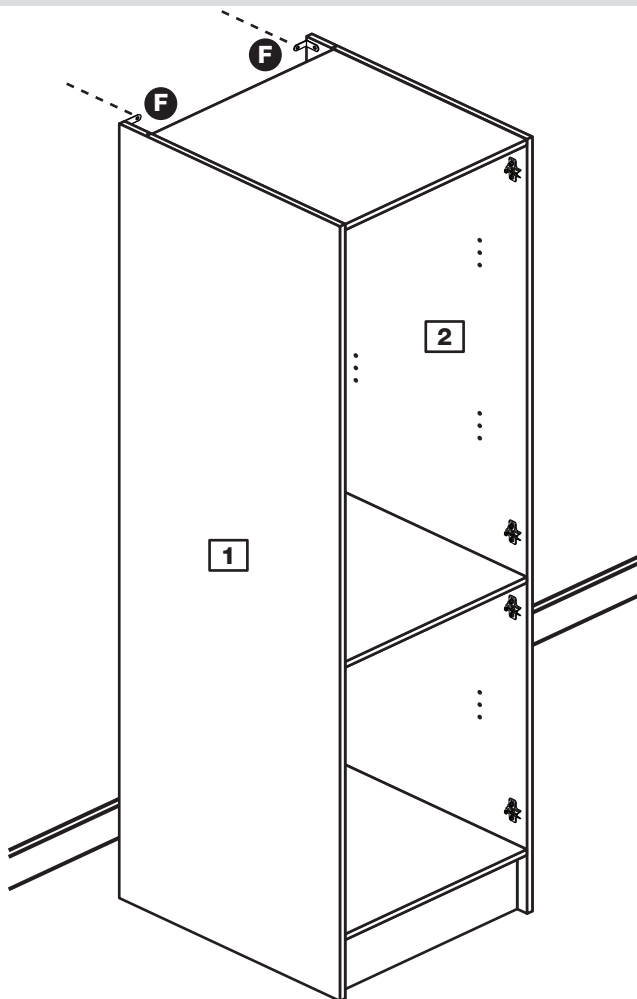

Step 13

Fit the shelf studs

Choose the height required for the 2 shelves.

For each shelf, push 4 shelf studs **E** into the holes in the side panels **1** and **2**.

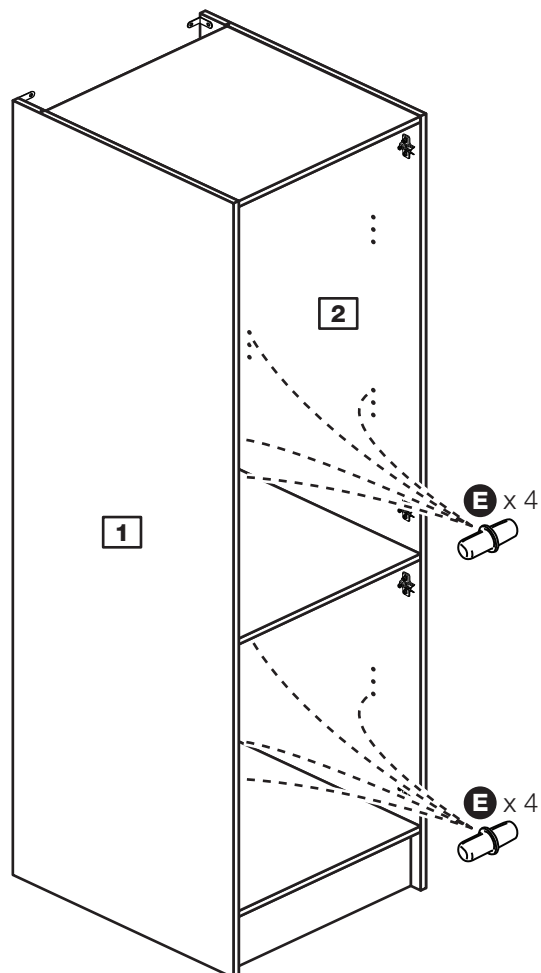

Assembly Instructions

Step 14

Fit the 2 shelves

Place the shelves **4** into the unit onto the shelf studs **E**.

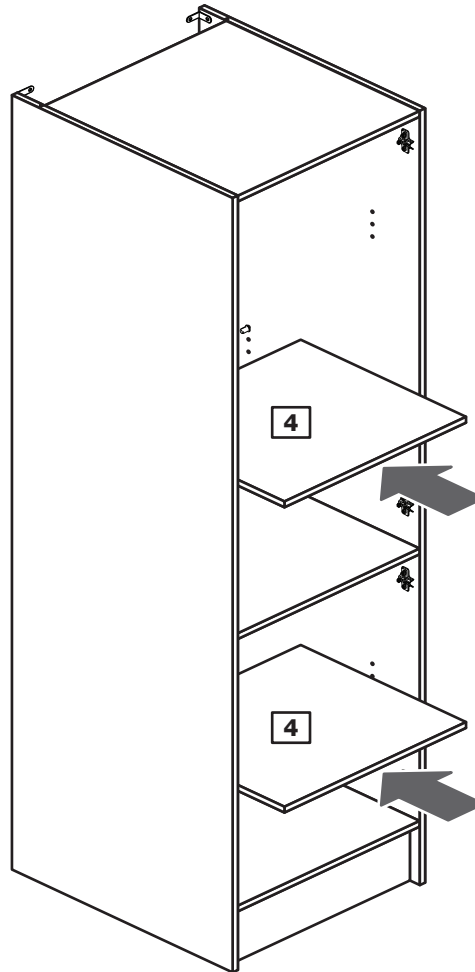

Step 15

Prepare the doors

Push fit 2 hinges **K** into the small door **6** and large door **7**.

Secure each hinge **K** with 2 screws **I**.

Note: Before securing with the screws, make sure that the hinges are positioned at 90 degrees with the front edge of the door.

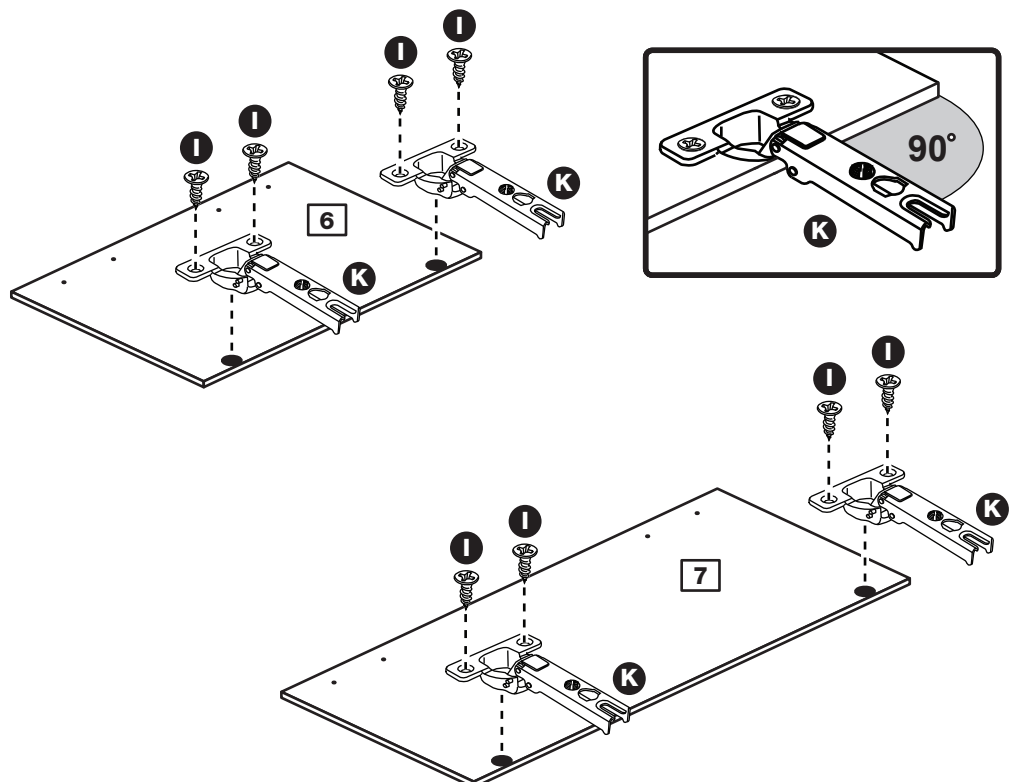

Assembly Instructions

Step 16

Drill the handle holes in the doors

Important: Only carry out this step if the hinge plates have been fitted to the left side.

Lay the small door **6** and large door **7** down onto a smooth surface.

Important: Carefully choose which holes you need to drill.

Check that the holes and hinges are in the same place as the diagrams.

Note: We recommend the use of a small piece of waste wood, placed behind the hole while drilling, to reduce the possibility of any breakout.

Using the pilot hole in the rear face of the doors **6** and **7** drill through the holes indicated opposite, using a 2.5mm diameter drill.

Turn the doors **6** and **7** over and open out the 2.5mm holes that you have just drilled by drilling back through them with a 5mm drill.

Carefully choose which 2 holes you will need to drill in each door.

This page shows the holes to drill if you have fitted the hinges to the left side.

Do not carry out this step if you have fitted the hinges to the right side, go to step 17.

Drill these 2 holes in the small door if you have fitted the hinges to the left side.

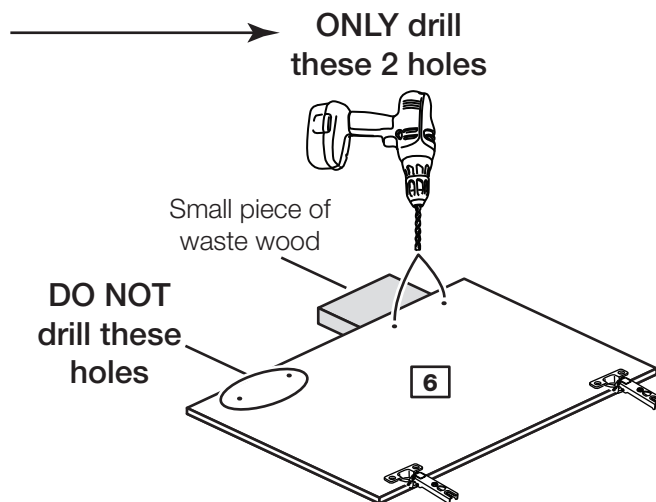
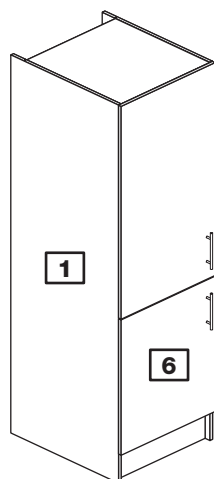

Drill these 2 holes in the large door if you have fitted the hinges to the left side.

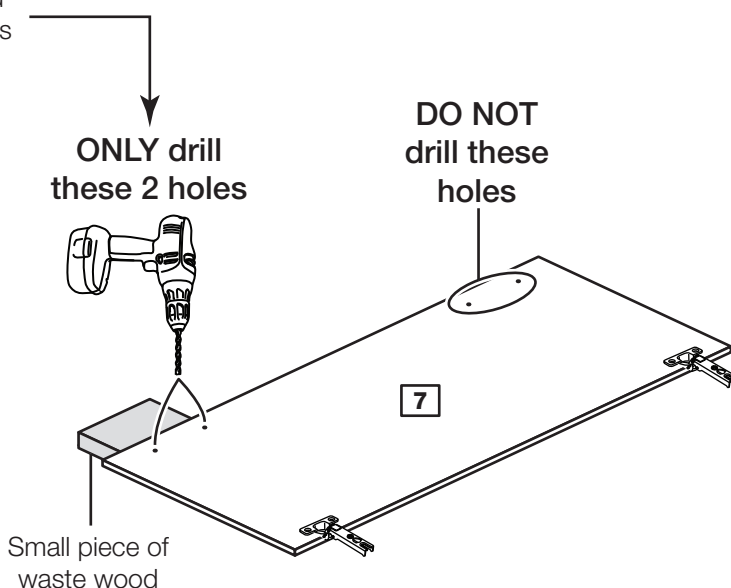
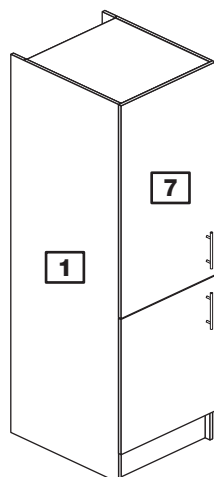

Assembly Instructions

Step 17

Drill the handle holes in the doors

Important: Only carry out this step if the hinge plates have been fitted to the right side.

Lay the small door **6** and large door **7** down onto a smooth surface.

Important: Carefully choose which holes you need to drill.

Check that the holes and hinges are in the same place as the diagrams.

Note: We recommend the use of a small piece of waste wood, placed behind the hole while drilling, to reduce the possibility of any breakout.

Using the pilot hole in the rear face of the doors **6** and **7** drill through the holes indicated opposite, using a 2.5mm diameter drill.

Turn the doors **6** and **7** over and open out the 2.5mm holes that you have just drilled by drilling back through them with a 5mm drill.

Carefully choose which 2 holes you will need to drill in each door.

This page shows the holes to drill if you have fitted the hinges to the right side.

Do not carry out this step if you have fitted the hinges to the left side, go back to step 16.

Drill these 2 holes in the small door if you have fitted the hinges to the right side.

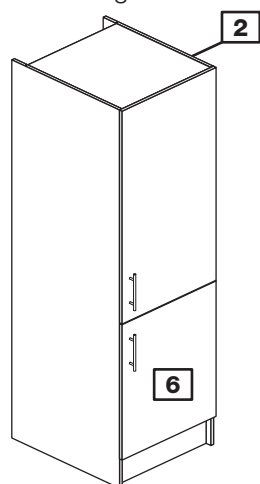

ONLY drill these 2 holes

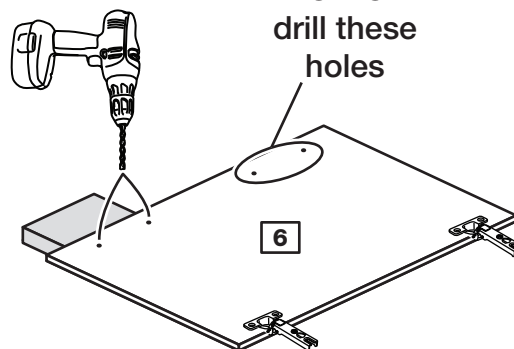

Drill these 2 holes in the large door if you have fitted the hinges to the right side.

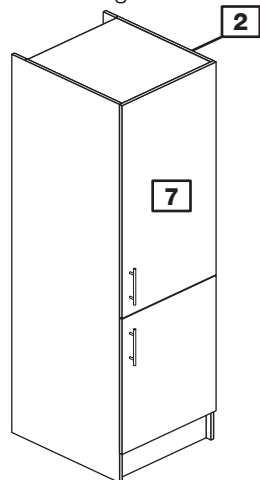

ONLY drill these 2 holes

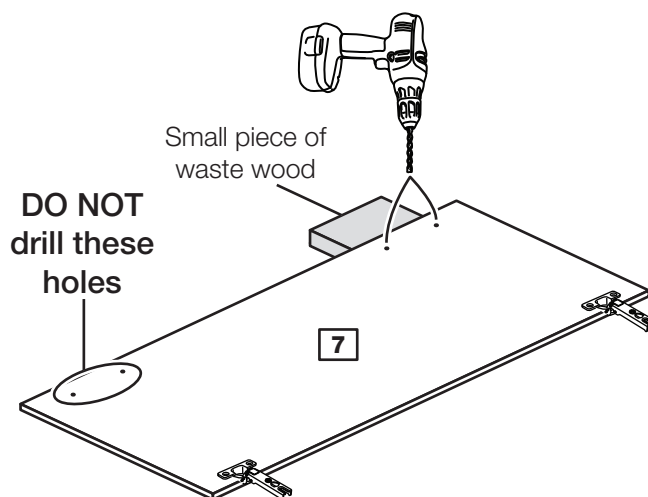

Assembly Instructions

Step 18

Fit doors and handles

2 people are needed here

Note: The easiest way to attach the doors **6** and **7** is to fit the top hinge first, then align and fit the other hinges.

a: Push the hinge **K** onto the front part of the hinge plate **J**.

b: Keep the hinge **K** FLAT against the hinge plate **J** as you slide it across as far as it will go. Tighten screw A.

c: The hinge **K** must be flat against the hinge plate **J** prior to any adjustment.

d: The hinge **K** must NOT be AT AN ANGLE to the hinge plate **J** when assembled. This would indicate that the recess at the bottom of screw B had not located in the slot in the hinge plate and the hinge would not be secure. Remove the hinge from the hinge plate and then re-assemble being careful to follow instructions a-c.

e: Attach a handle **L a** to the doors **6** and **7** using 2 screws **L b**.

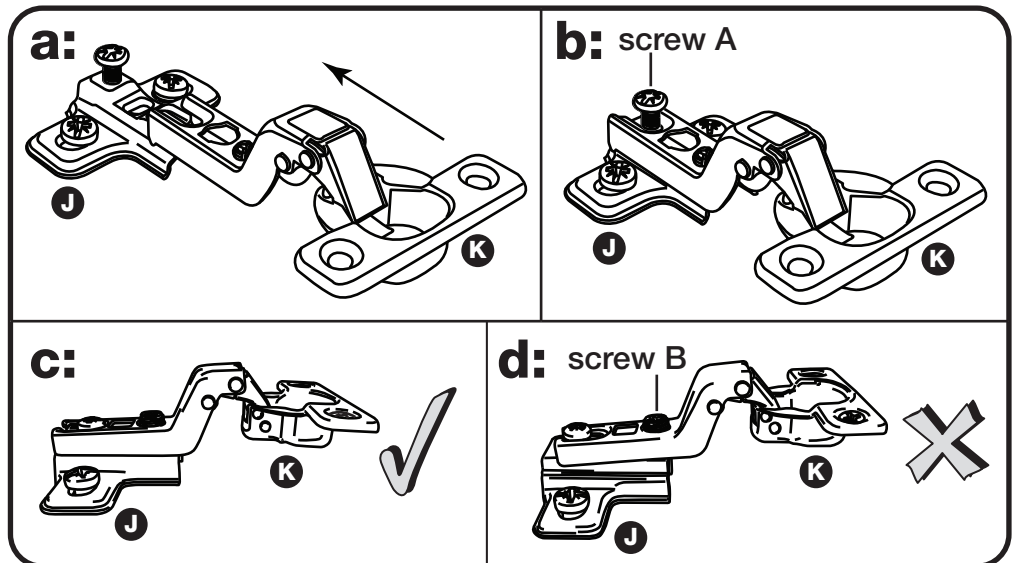

This shows the doors being fitted to hinge plates on the right side. You may have fitted them to the left side.

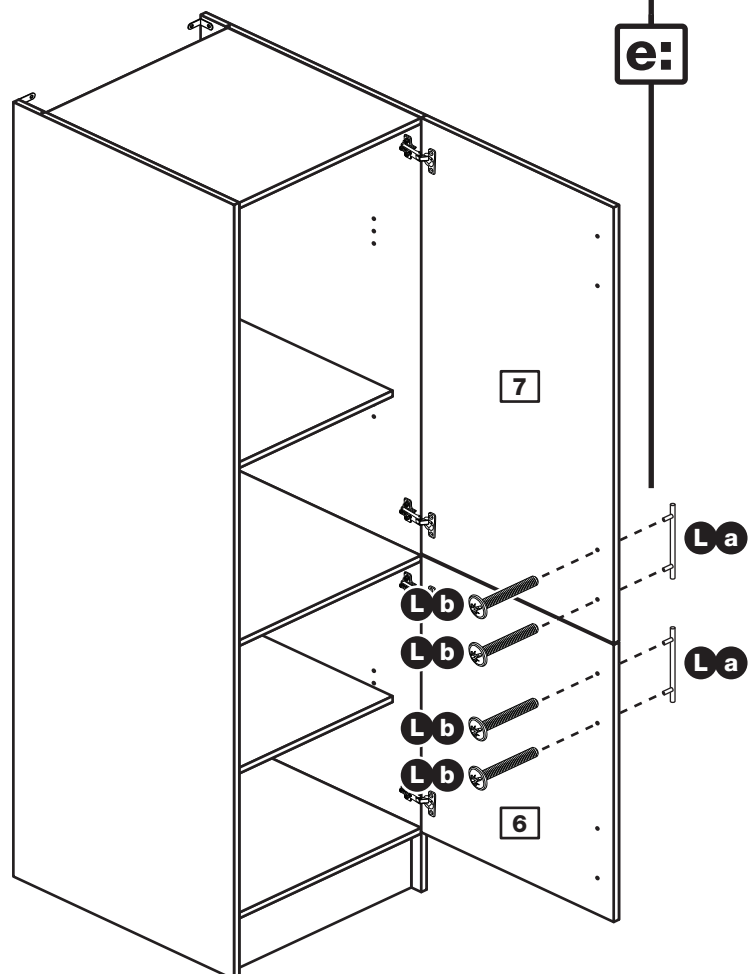

Assembly Instructions

Step 19

Adjust the doors if needed

a: Height adjustment.

Loosen screws A on hinge plates and move door up or down as required.

Retighten screw A.

b: Forward and Back adjustment.

Loosen screw B on hinge plate and move door in or out as required.

Retighten screw B.

c: Sideways adjustment.

To move door 'out' loosen screw C.

To move door 'in' tighten screw C

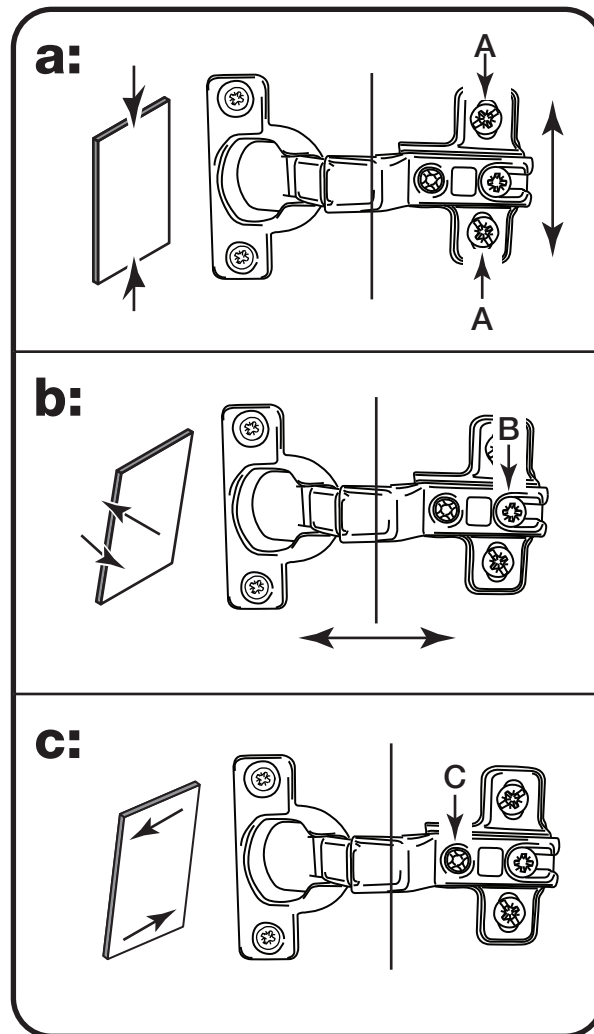

Assembly Instructions

Step 20

Fit the 4 door buffers

Stick a door buffer **G** onto each corner of the doors **6** and **7** so that they hit the edge of the side panel when the door is closed.

Assembly is complete



Warning: The unit is heavy. Lift with care.

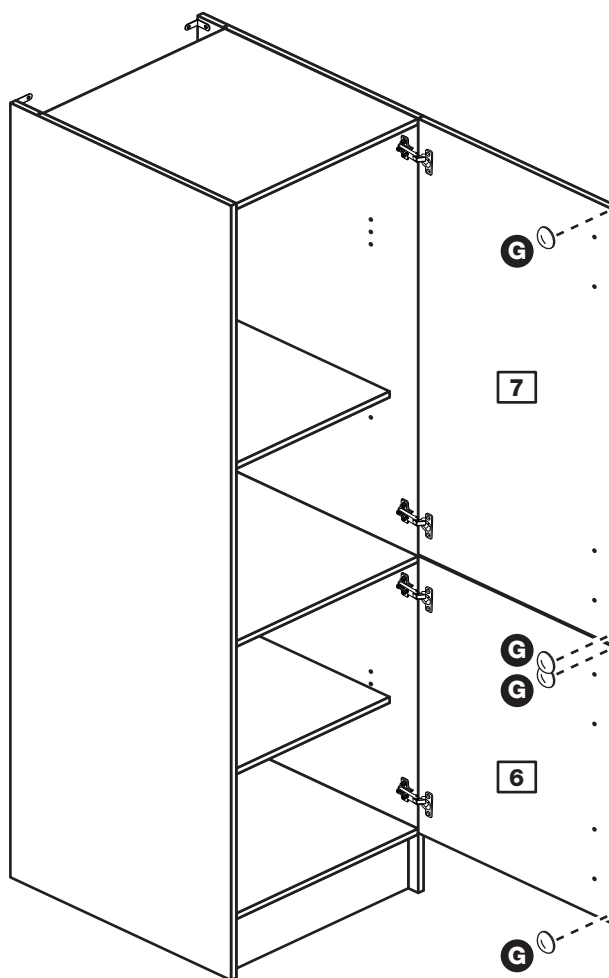

If you need help or have damaged or missing parts, call the Customer Helpline: 08456 400800 and quote the reference numbers on the component pages.

Argos Ltd, 489-499 Avebury Boulevard, Central Milton Keynes, MK9 2NW

Athina - 500 Tall Cupboard

Assembly Instructions - Please keep for future reference

608/0794

608/0914

608/0859

608/0976

608/2967

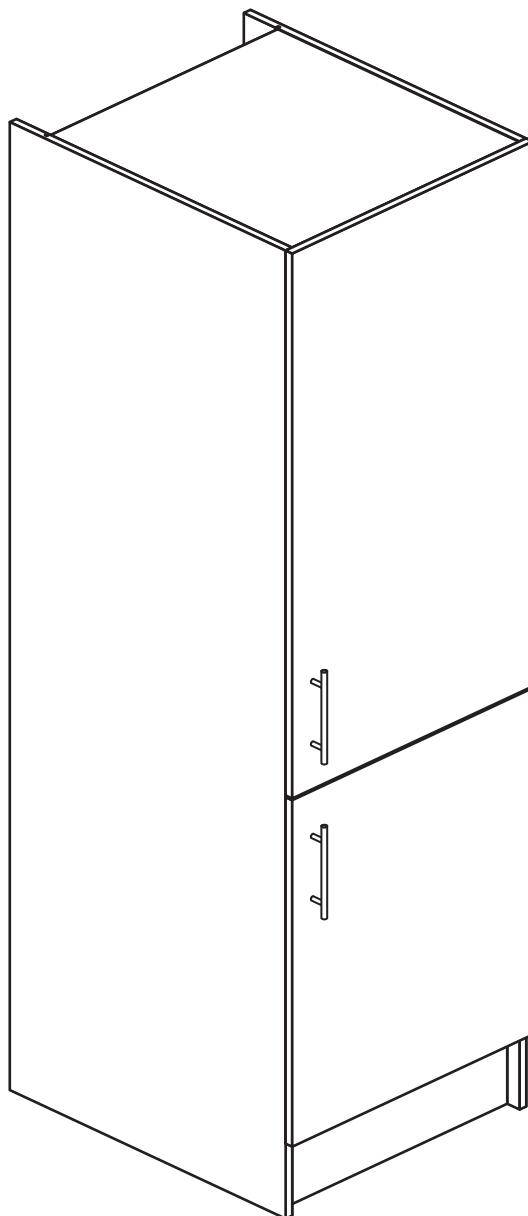

Dimensions

Width - 50cm

Depth - 59cm

Height - 200cm



**MADE IN
BRITAIN**

Important - Please read these instructions fully before starting assembly

If you need help or have damaged or missing parts, call the **Customer Helpline: 08456 400800**



Safety and Care Advice

Important - Please read these instructions fully before starting assembly

- **Warning:** This unit weighs approximately 51kgs. Please lift with care.

- Check you have all the components and tools listed on pages 2 and 3.

- Remove all fittings from the plastic bags and separate them into their groups.

- Keep children and animals away from the work area, small parts could choke if swallowed.

- Make sure you have enough space to layout the parts before starting.

- Do not stand or put weight on the product, this could cause damage.

- Assemble the item as close to its final position (in the same room) as possible.

- Assemble on a soft level surface to avoid damaging the unit or your floor (use opened out unit carton).



- We do not recommend the use of power drill/drivers **for inserting screws**, as this could damage the unit. Only use hand screwdrivers.

- **Safety note:** It is recommended that this unit is secured to a wall using the brackets supplied.

- Dispose of all packaging carefully and responsibly.

Care and maintenance

- Only clean using a damp cloth and mild detergent, do not use bleach or abrasive cleaners.

- From time to time check that there are no loose screws on this unit.

- This product should not be discarded with household waste. Take to your local authority waste disposal centre.

Note: If required the next page can be cut out and used as reference throughout the assembly. Keep this page with these instructions for future reference.

Components - Panels

If you have damaged or missing components, call the **Customer Helpline: 08456 400800** quoting the reference numbers below

Please check you have all the panels listed below

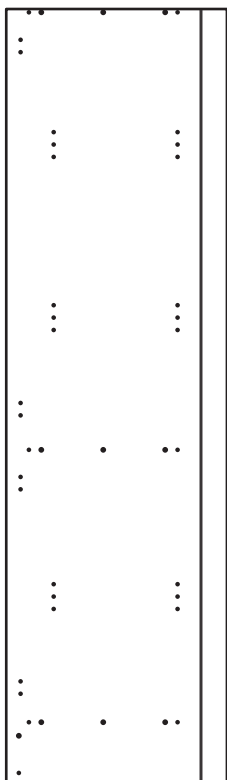

1 Left Side (D0328A)
(2000 X 570mm)

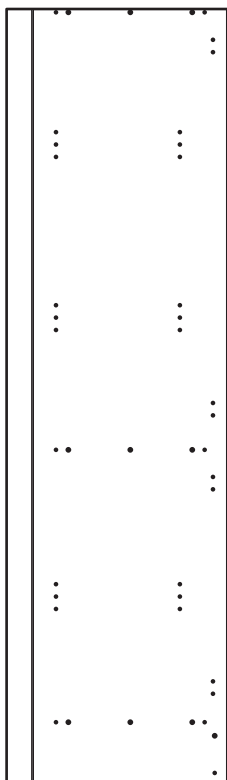

2 Right Side (D0329A)
(2000 X 570mm)

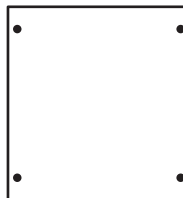

3 Horizontal (D0319A)
(470 X 499mm) x 3



4 Shelf (D0320A)
(469 x 427mm) x 3



5 Plinth (D0322A)
(470 x 150mm)

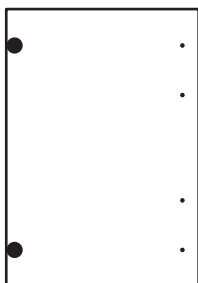

6 Small Door (D0317A)
(716 x 497mm)

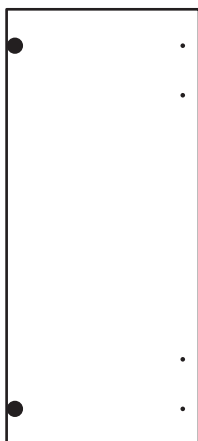

7 Large Door (D0330A)
(1126 x 497mm)

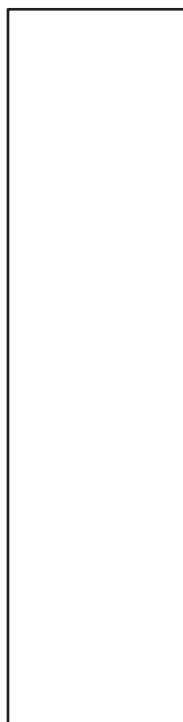

8 Back (X741)
(1848 x 480mm)











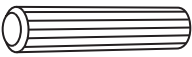
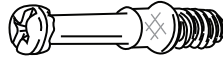

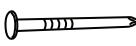
Components - Fittings

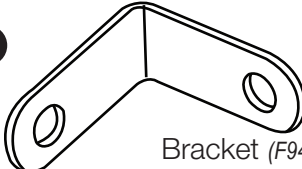
If you have damaged or missing components, call the **Customer Helpline: 08456 400800** quoting the reference numbers below

Please check you have all the fittings listed below

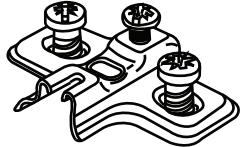
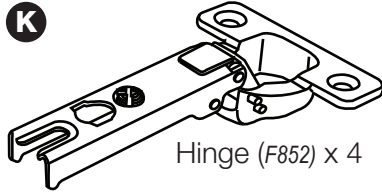
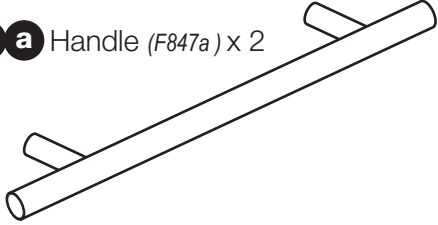
Note: The quantities below are the correct amount to complete the assembly. In some cases more fittings may be supplied than are required.

| | | |
|---|--|--|
| <p>A </p> <p>Wooden dowel (F22) x 20</p> | <p>B </p> <p>Metal dowel (F901) x 14</p> | <p>C </p> <p>Large locking nut (F900) x 14</p> |
| <p>D </p> <p>Nail (F51) x 8</p> | <p>E </p> <p>Shelf support (F110) x 12</p> | <p>F </p> <p>Bracket (F945) x 2</p> |
| <p>G </p> <p>Door Buffer (F137) x 4</p> | <p>H </p> <p>13mm Screw (F79) x 2</p> | <p>I </p> <p>13mm Screw (F63) x 8</p> |
| <p>J </p> <p>Hinge Plate (F853) x 4</p> | <p>K </p> <p>Hinge (F852) x 4</p> | |
| <p>L a  Handle (F847a) x 2</p> <p>L b  Handle Screw (F847b) x 4</p> | | |

Tools required

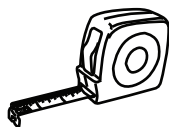

Rule



Cross-head screwdriver



Scissors



Hammer



Eye protection (when using a hammer or drill)



Electric drill

Ruler - Use this ruler to help correctly identify the screws

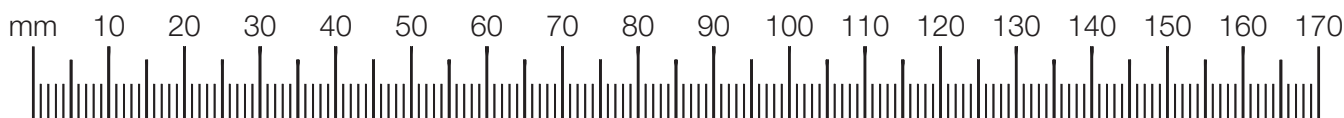

Assembly Instructions

If you have damaged or missing components, call the
Customer Helpline: 08456 400800 quoting the reference
numbers below

Step 1

Choose which way you would like the doors to open

You can fit the doors to the left side or right side.

If you would like your doors to open this way, fit the hinge plates to the left side

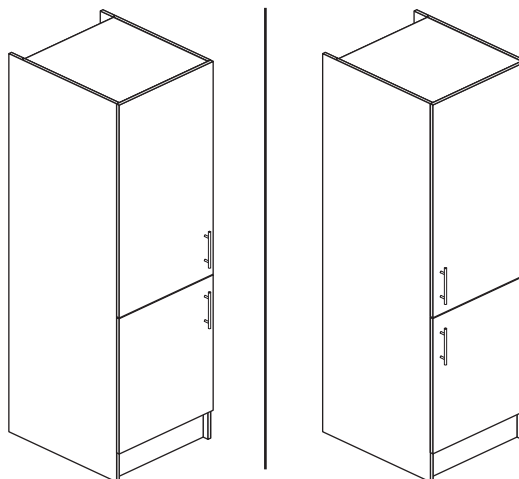

If you would like your doors to open this way, fit the hinge plates to the right side

Step 2

Fit a bracket to the left side

Fit a bracket **F** to the left side **1**, 10mm down from the top edge, see diagram.

Secure the bracket **F** using screw **H**.

Note: The bracket must be flush with the back edge of the panel.

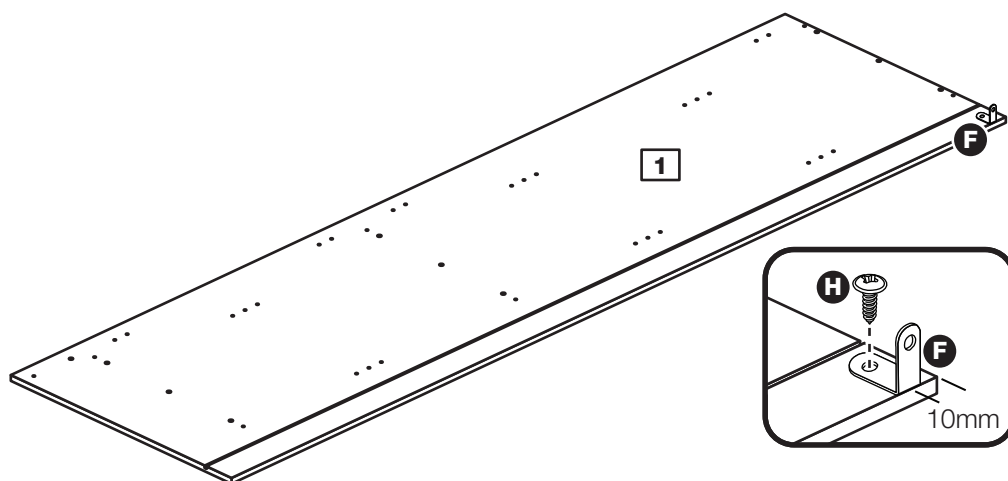

Step 3

Prepare the left side

a: Refer to step 1 and if required, fit 4 hinge plates **J** onto the left side **1**, making sure that the slot is facing towards the front edge.

b: Screw 7 metal dowels **B** into the holes shown on the left side **1**.

Note: Tighten metal dowels up fully against the panels.

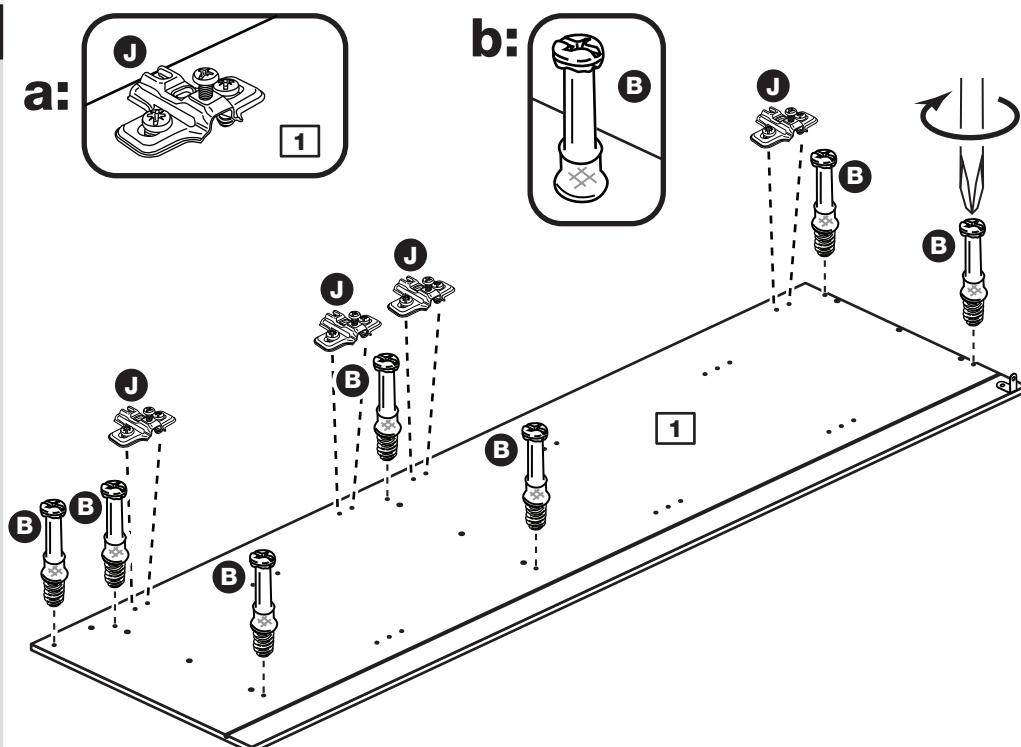

Assembly Instructions

Step 4

Fit 2 brackets to the right side

Fit a bracket **F** to the right side **2**, 10mm down from the top edge, see diagram.

Secure the bracket **F** using screw **H**.

Note: The bracket must be flush with the back edge of the panel.

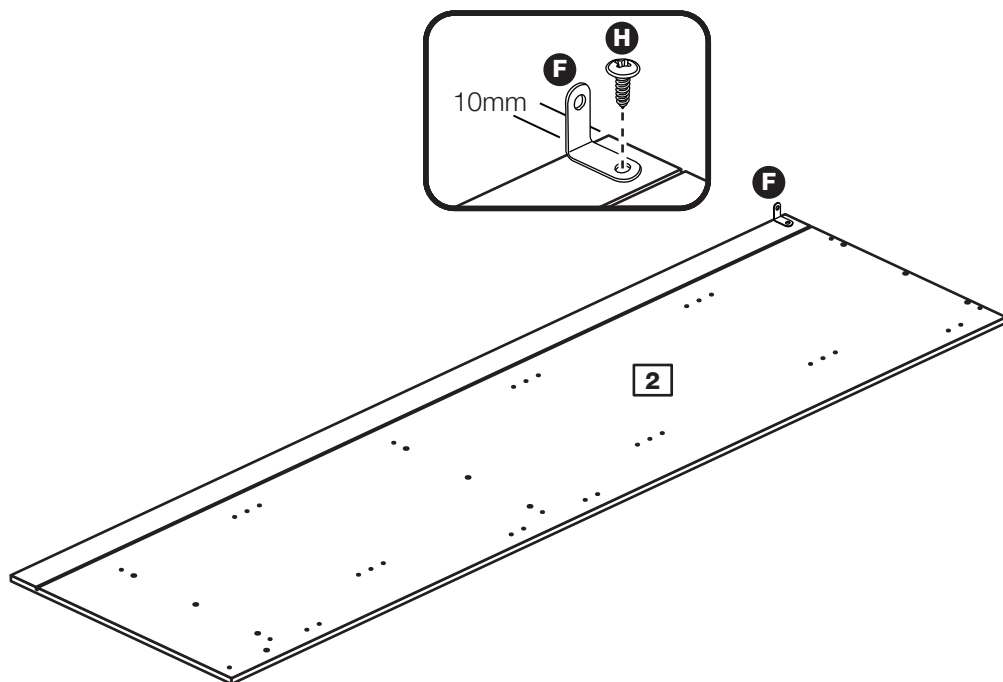

Step 5

Prepare the right side

a: Refer to step 1 and if required, fit 4 hinge plates **J** onto the right side **2**, making sure that the slot is facing towards the front edge.

b: Screw 7 metal dowels **B** into the holes shown on the right side **2**.

Note: Tighten metal dowels up fully against the panels.

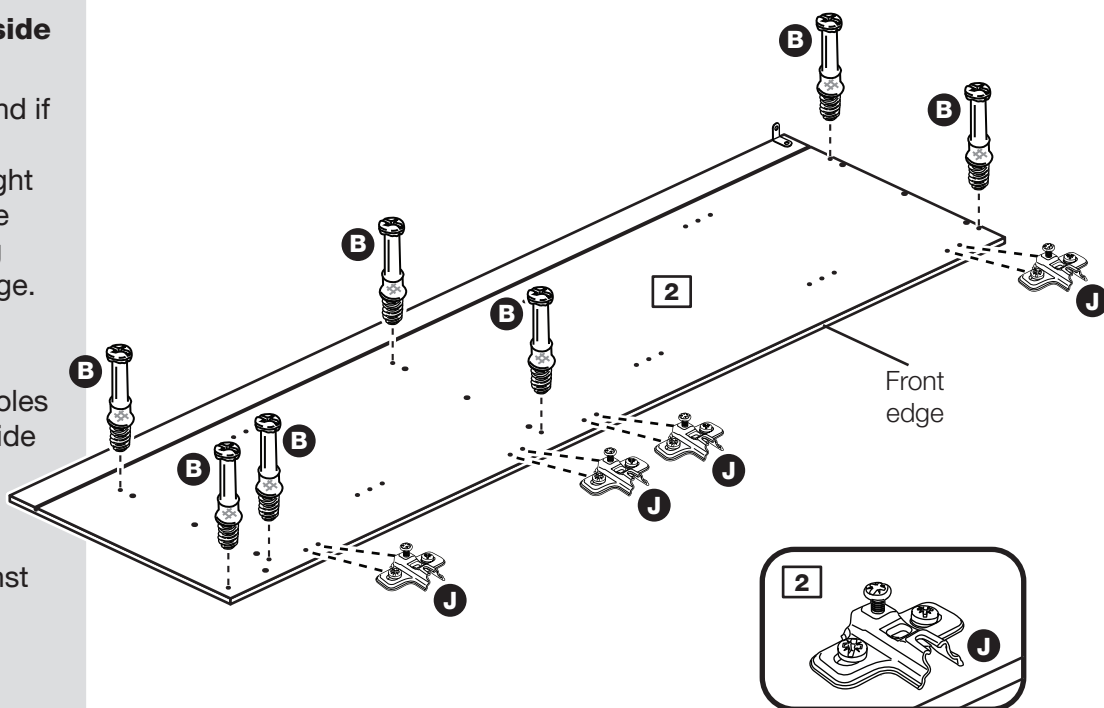

Assembly Instructions

Step 6

Prepare the 3 horizontals

Insert 4 large locking nuts **C** into each horizontal **3** as shown.

Note: Arrow on locking nut **must** point towards hole in edge of panel.

Tap 6 wooden dowels **A** into each horizontal **3** as shown.

Note: Wooden dowels **must not** stick out from the edge by more than 10mm or they may damage other panels.

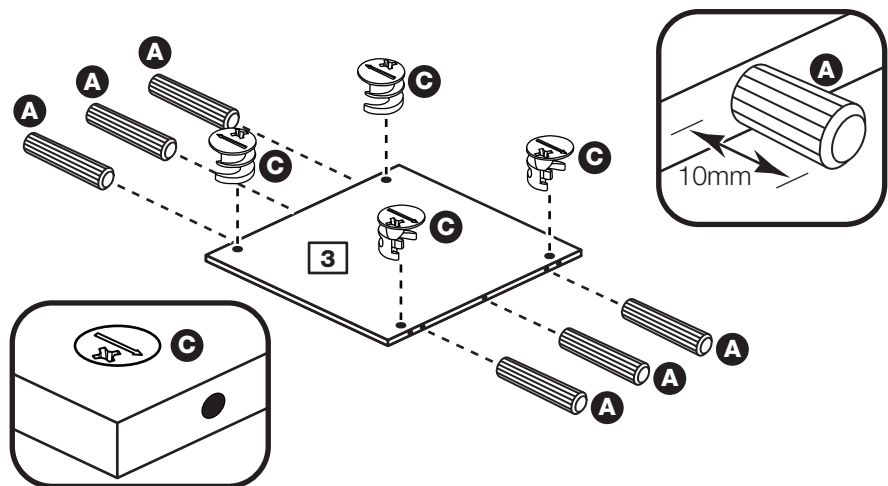

Step 7

Fit the 3 horizontals to the right side

Push the horizontals **3** onto the right side **2**.

Use a screwdriver to tighten the 2 large locking nuts **C** fitted to each horizontal **3**.

Note: Turn the large locking nuts **C** as far as they will go - more than 1/2 a turn.

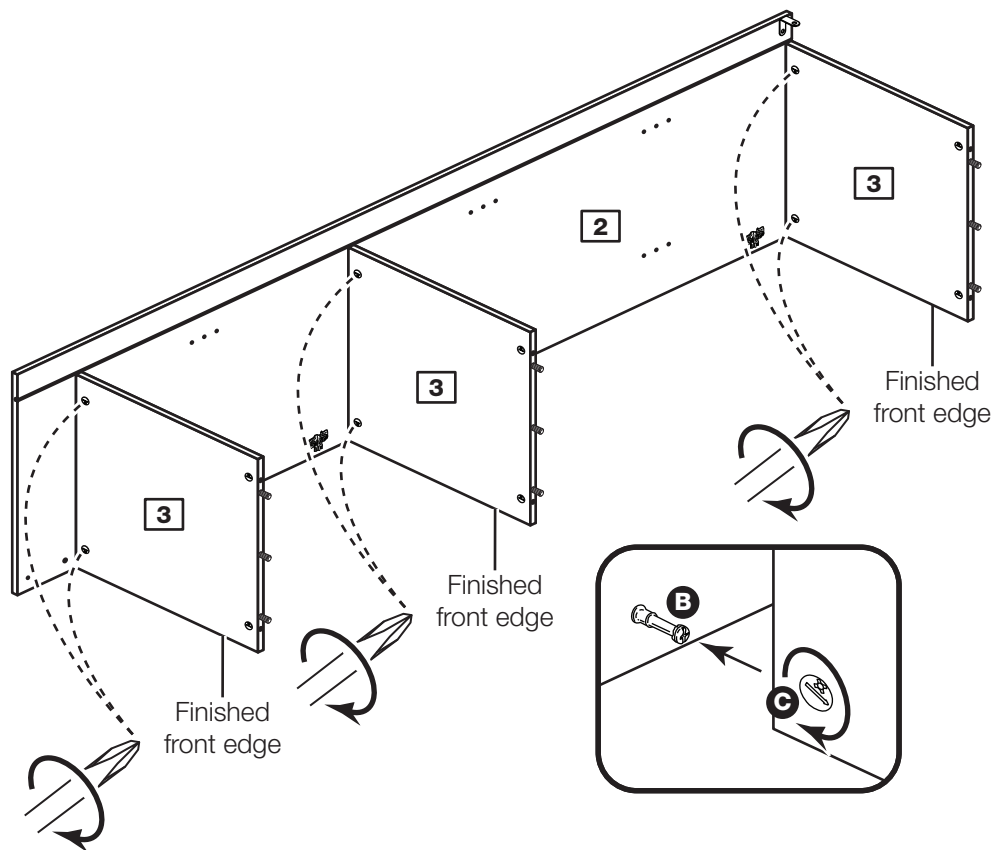

Step 8

Prepare the plinth

Insert 2 large locking nuts **C** into the plinth **5** as shown.

Tap 2 wooden dowels **A** into the plinth **5** as shown.

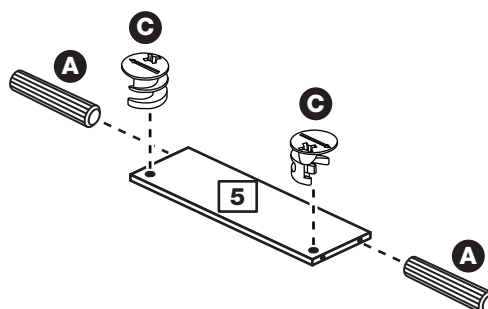

Assembly Instructions

Step 9

Fit the plinth to the right side

Push the plinth **5** onto the right side **2**, as shown.

Use a screwdriver to tighten the large locking nut **C** fitted to the plinth **5**, as shown.

Note: Turn the large locking nut **C** as far as they will go - more than 1/2 a turn.

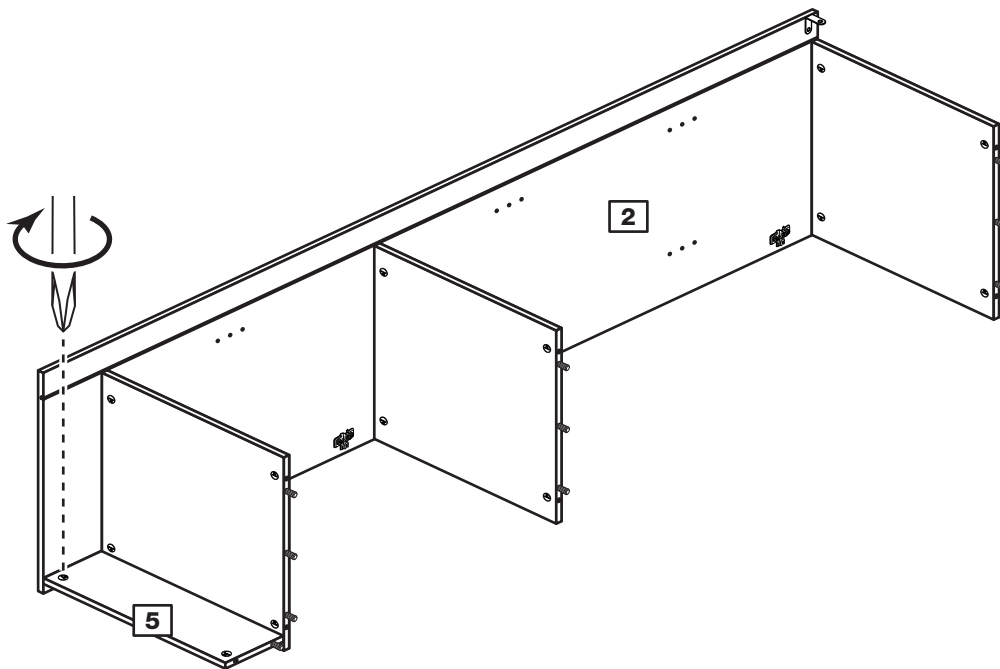

Step 10

Fit the left side

Push the left side **1** onto the assembly.

Use a screwdriver to tighten the 7 large locking nuts **C** fitted to the 3 horizontals **3** and plinth **5**.

Note: Turn the large locking nuts **C** as far as they will go - more than 1/2 a turn.

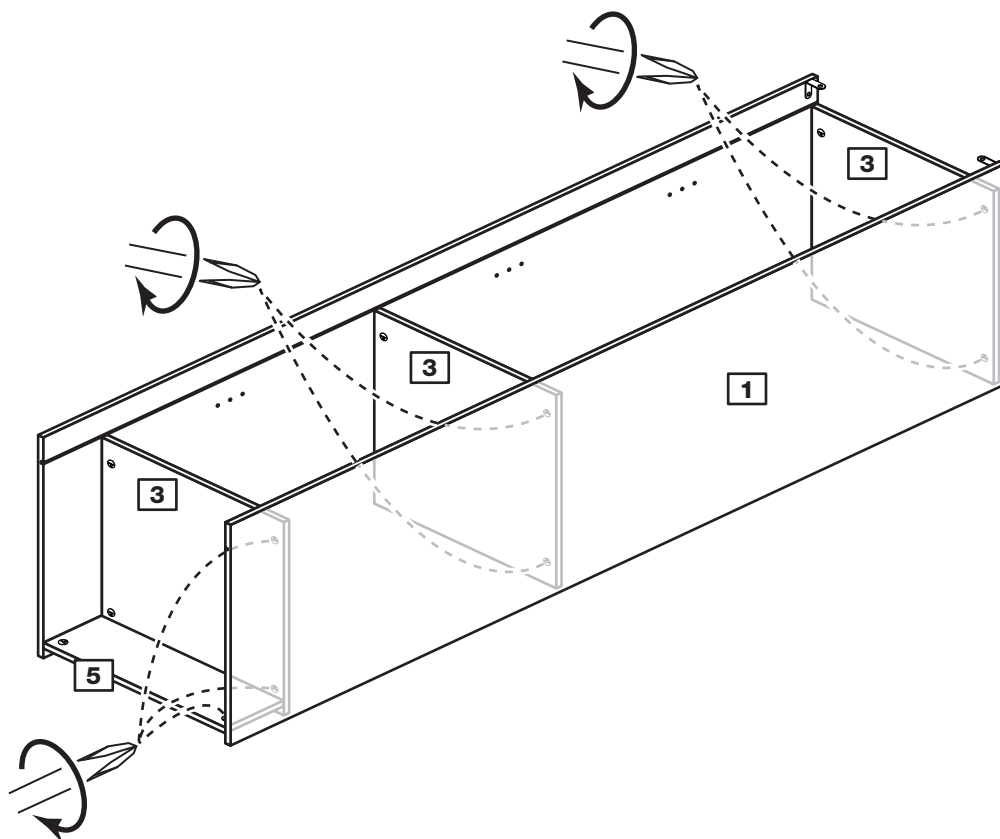

Assembly Instructions

Step 11

Fit the back

a: Square up the unit by making sure that measurement **x to x** equals **y to y**.

b: Slide the back **8** into the grooves along the left **1** and right **2** sides, as shown.

c: Secure the back **8** by tapping 4 nails **D** down into the back edge of the top horizontal **3** and 4 nails **D** into the back edge of the bottom horizontal **3**.

a: The measurement from top corner X to bottom corner X must be equal to the measurement from top corner Y to bottom corner Y

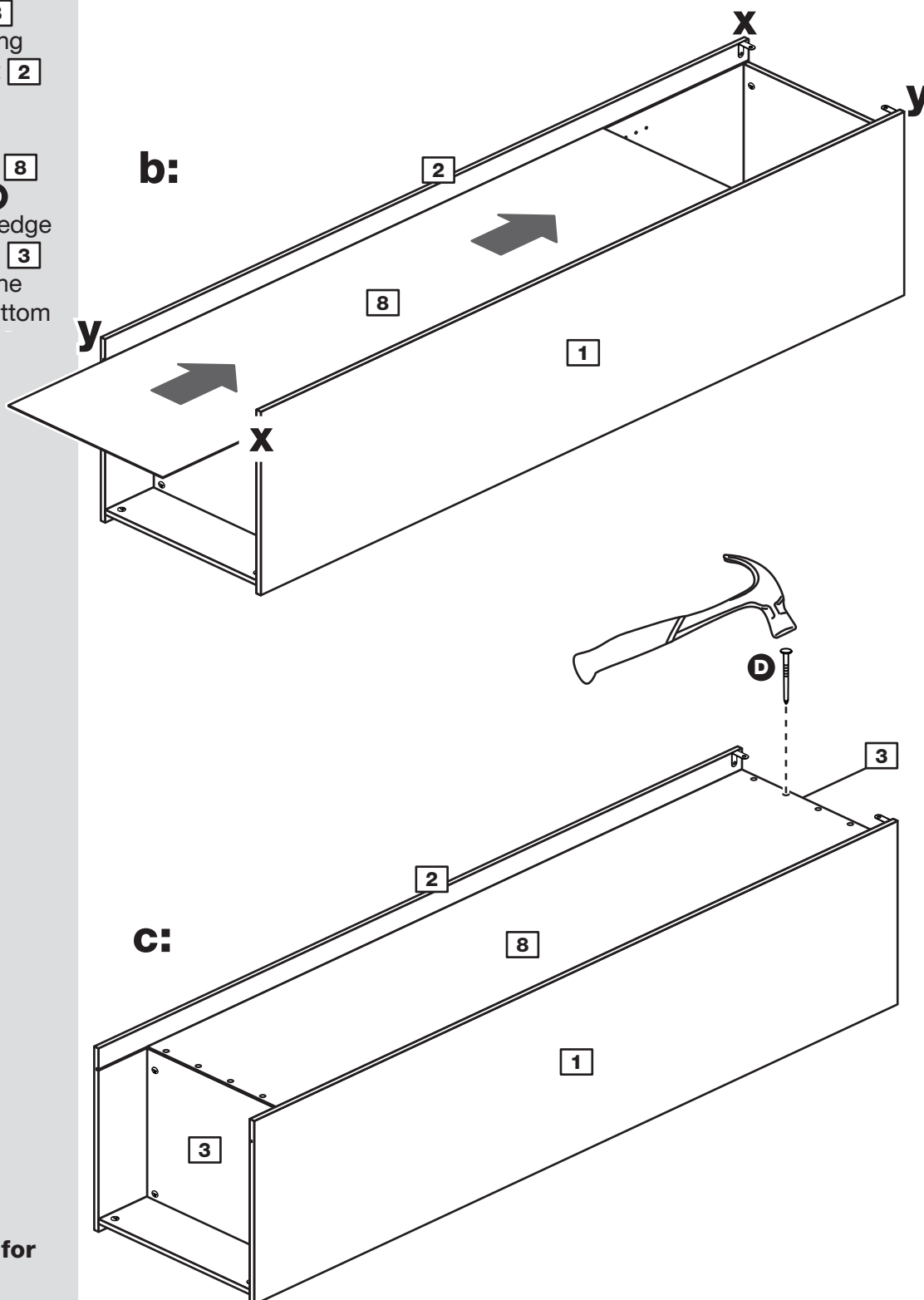

Stand the unit up for the next stage.

Assembly Instructions

Step 12

Secure the unit to the wall

Using the brackets **F** fitted to the back edge of the sides **1** and **2** screw the unit to the wall.

Fixings are not supplied as they will need to suit the wall type, and the length of screw will depend on the distance of the back of the Unit to the wall.



Warning: Take care when drilling the wall that you do not drill into any pipes, wires etc. If in doubt, consult an expert.

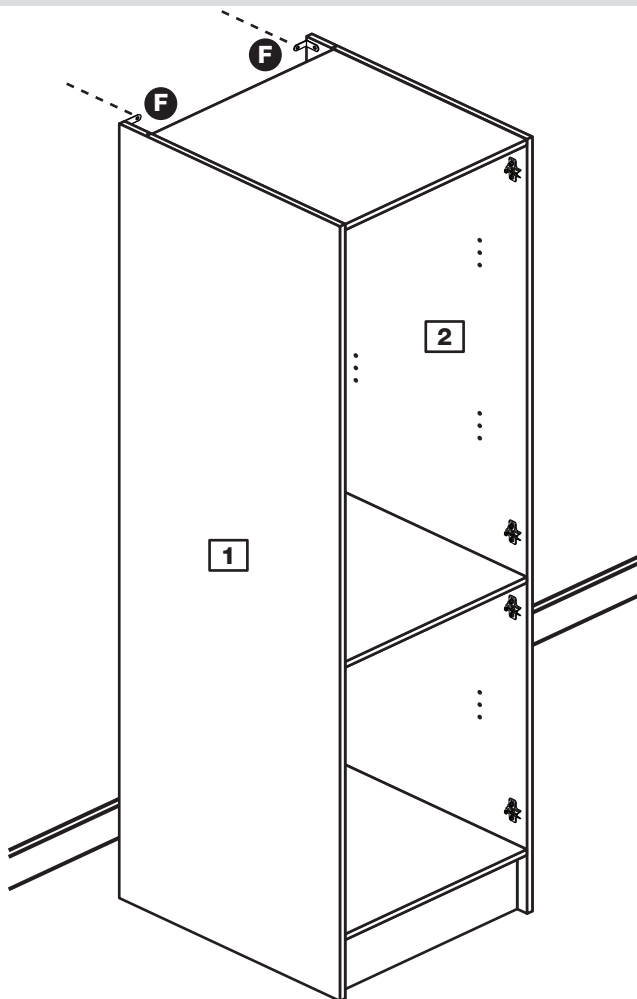

Step 13

Fit the shelf studs

Choose the height required for the 3 shelves.

For each shelf, push 4 shelf studs **E** into the holes in the side panels **1** and **2**.

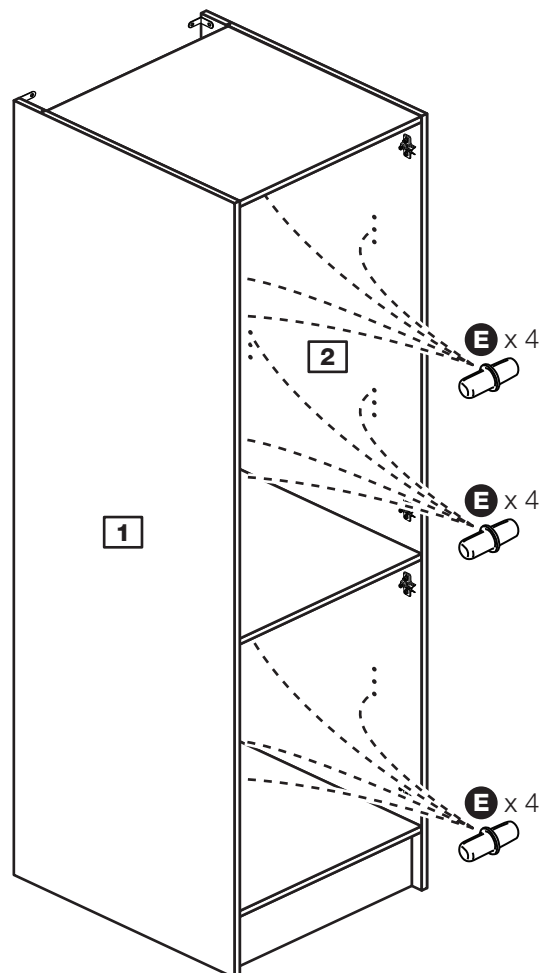

Assembly Instructions

Step 14

Fit the 3 shelves

Place the 3 shelves **4** into the unit onto the shelf studs **E**.

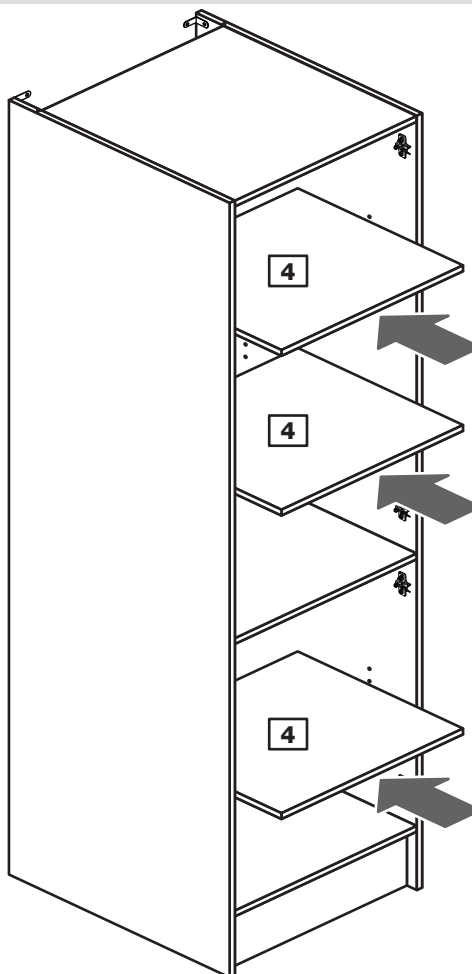

Step 15

Prepare the doors

Push fit 2 hinges **K** into the small door **6** and large door **7**.

Secure each hinge **K** with 2 screws **I**.

Note: Before securing with the screws, make sure that the hinges are positioned at 90 degrees with the front edge of the door.

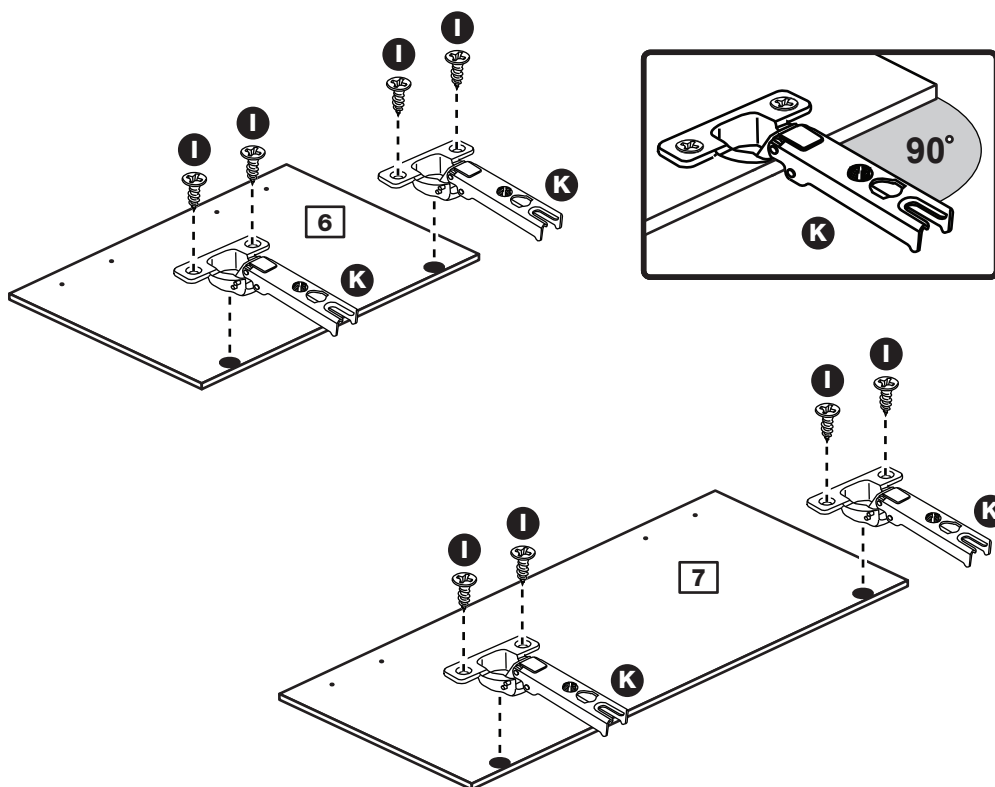

Assembly Instructions

Step 16

Drill the handle holes in the doors

Important: Only carry out this step if the hinge plates have been fitted to the left side.

Lay the small door **6** and large door **7** down onto a smooth surface.

Important: Carefully choose which holes you need to drill.

Check that the holes and hinges are in the same place as the diagrams.

Note: We recommend the use of a small piece of waste wood, placed behind the hole while drilling, to reduce the possibility of any breakout.

Using the pilot hole in the rear face of the doors **6** and **7** drill through the holes indicated opposite, using a 2.5mm diameter drill.

Turn the doors **6** and **7** over and open out the 2.5mm holes that you have just drilled by drilling back through them with a 5mm drill.

Carefully choose which 2 holes you will need to drill in each door.

This page shows the holes to drill if you have fitted the hinges to the left side.

Do not carry out this step if you have fitted the hinges to the right side, go to step 17.

Drill these 2 holes in the small door if you have fitted the hinges to the left side.

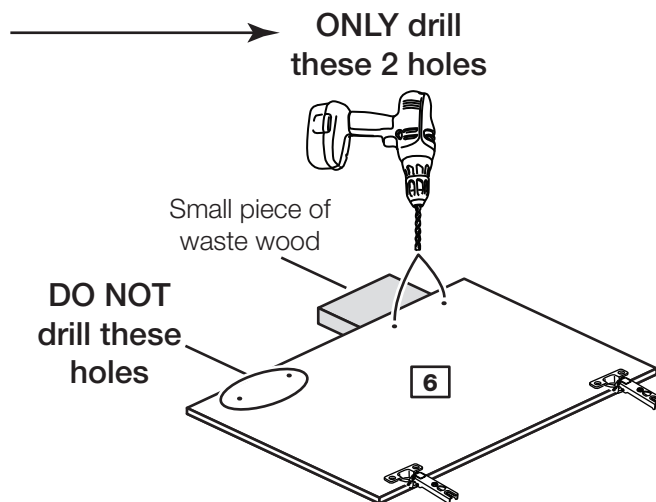
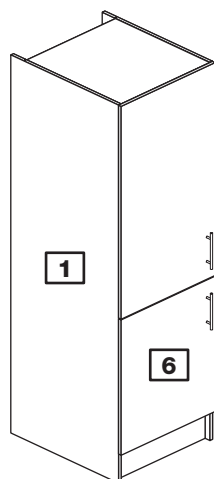

Drill these 2 holes in the large door if you have fitted the hinges to the left side.

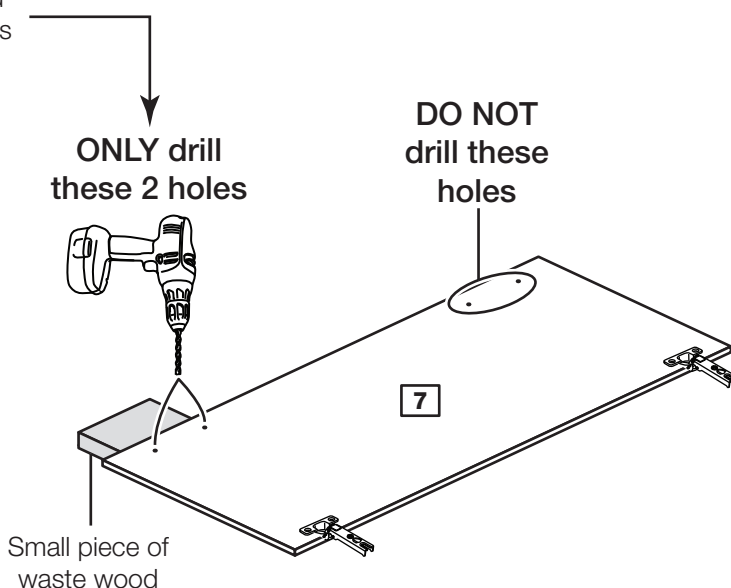
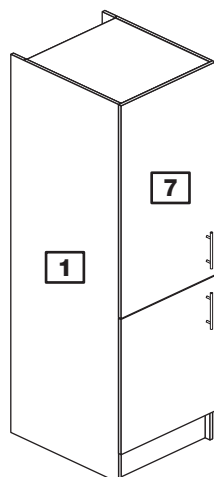

Assembly Instructions

Step 17

Drill the handle holes in the doors

Important: Only carry out this step if the hinge plates have been fitted to the right side.

Lay the small door **6** and large door **7** down onto a smooth surface.

Important: Carefully choose which holes you need to drill.

Check that the holes and hinges are in the same place as the diagrams.

Note: We recommend the use of a small piece of waste wood, placed behind the hole while drilling, to reduce the possibility of any breakout.

Using the pilot hole in the rear face of the doors **6** and **7** drill through the holes indicated opposite, using a 2.5mm diameter drill.

Turn the doors **6** and **7** over and open out the 2.5mm holes that you have just drilled by drilling back through them with a 5mm drill.

Carefully choose which 2 holes you will need to drill in each door.

This page shows the holes to drill if you have fitted the hinges to the right side.

Do not carry out this step if you have fitted the hinges to the left side, go back to step 16.

Drill these 2 holes in the small door if you have fitted the hinges to the right side.

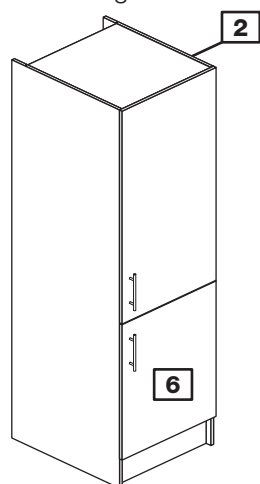

ONLY drill these 2 holes

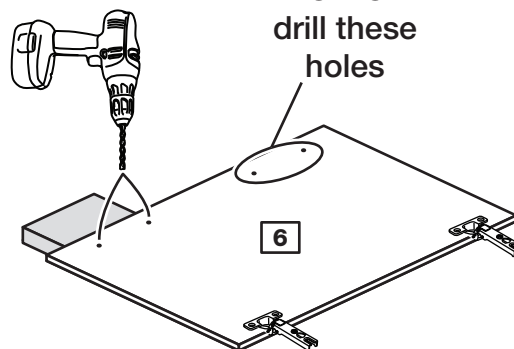

Drill these 2 holes in the large door if you have fitted the hinges to the right side.

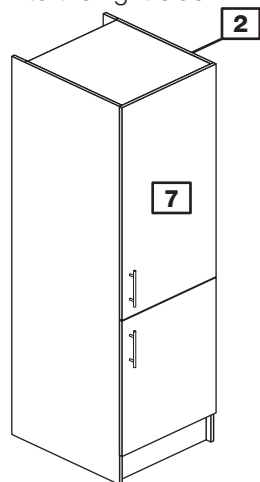

ONLY drill these 2 holes

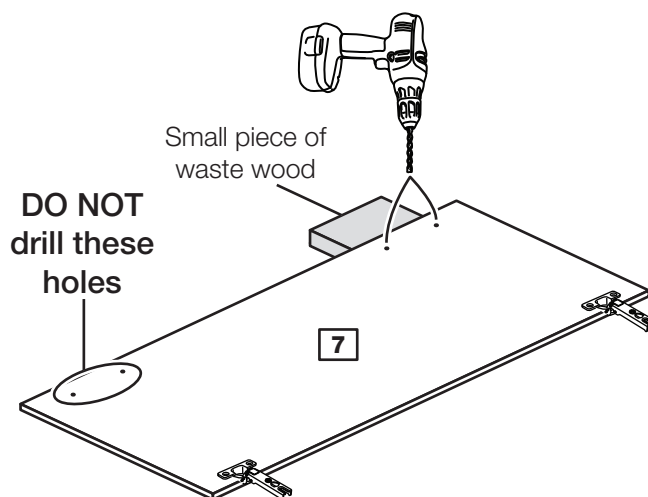

Assembly Instructions

Step 18

Fit doors and handles

2 people are needed here

Note: The easiest way to attach the doors **6** and **7** is to fit the top hinge first, then align and fit the other hinges.

a: Push the hinge **K** onto the front part of the hinge plate **J**.

b: Keep the hinge **K** FLAT against the hinge plate **J** as you slide it across as far as it will go. Tighten screw A.

c: The hinge **K** must be flat against the hinge plate **J** prior to any adjustment.

d: The hinge **K** must NOT be AT AN ANGLE to the hinge plate **J** when assembled. This would indicate that the recess at the bottom of screw B had not located in the slot in the hinge plate and the hinge would not be secure. Remove the hinge from the hinge plate and then re-assemble being careful to follow instructions a-c.

e: Attach a handle **L a** to the doors **6** and **7** using 2 screws **L b**.

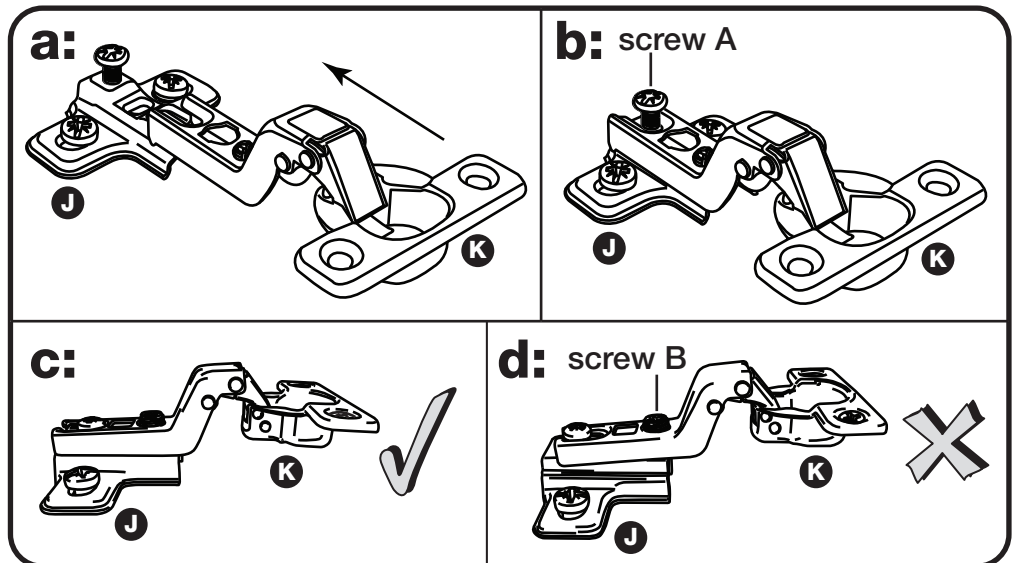

This shows the doors being fitted to hinge plates on the right side. You may have fitted them to the left side.

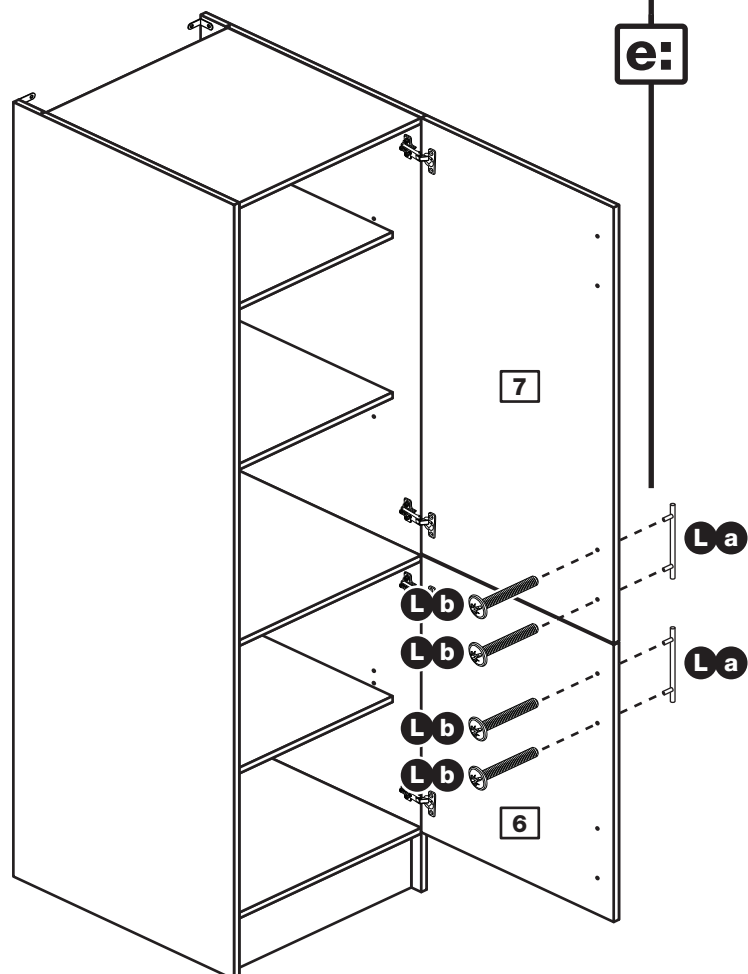

Assembly Instructions

Step 19

Adjust the doors if needed

a: Height adjustment.

Loosen screws A on hinge plates and move door up or down as required.

Retighten screw A.

b: Forward and Back adjustment.

Loosen screw B on hinge plate and move door in or out as required.

Retighten screw B.

c: Sideways adjustment.

To move door 'out' loosen screw C.

To move door 'in' tighten screw C

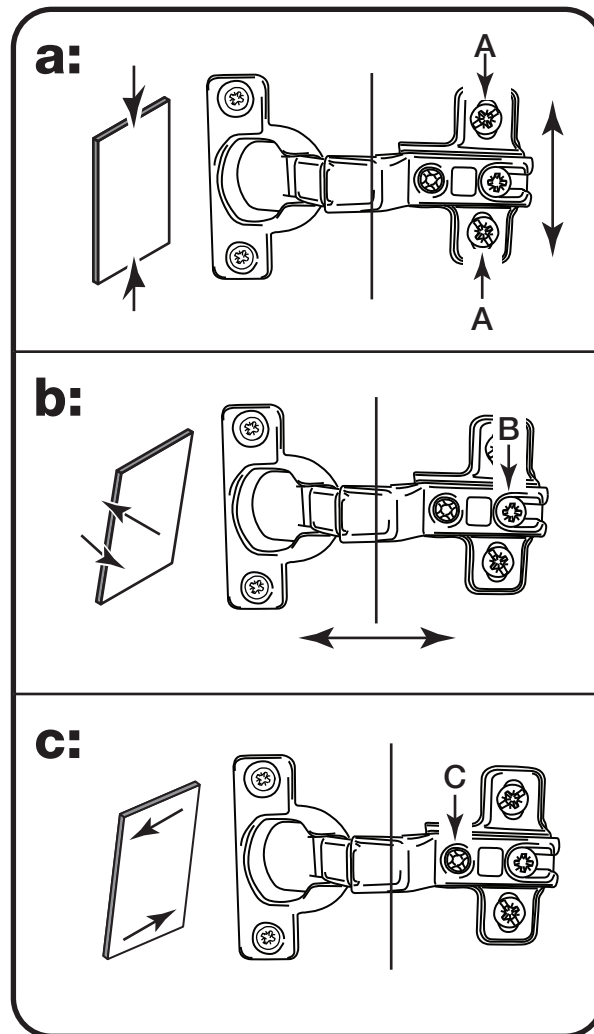

Assembly Instructions

Step 20

Fit the 4 door buffers

Stick a door buffer **G** onto each corner of the doors **6** and **7** so that they hit the edge of the side panel when the door is closed.

Assembly is complete



Warning: The unit is heavy. Lift with care.

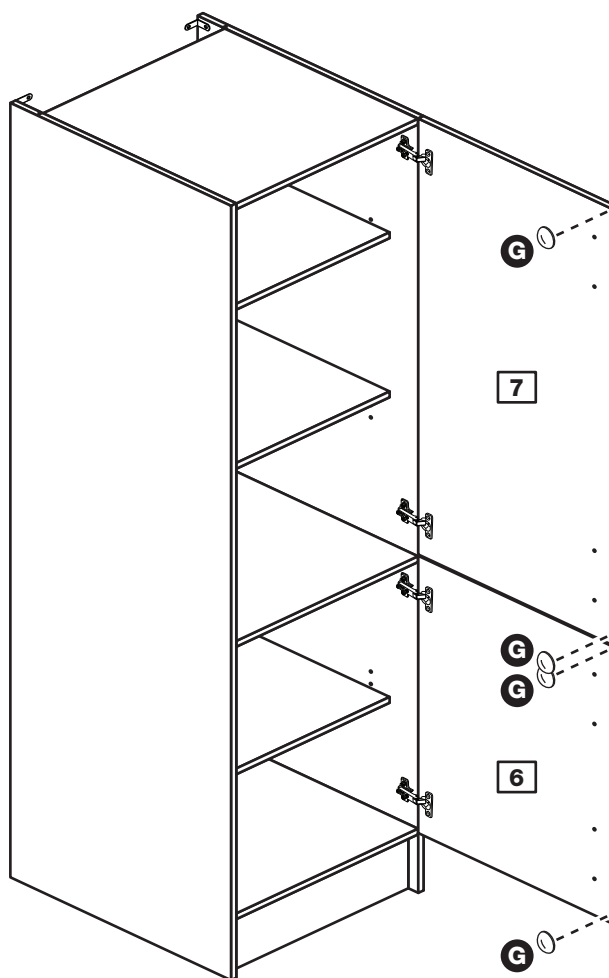

If you need help or have damaged or missing parts, call the Customer Helpline: 08456 400800 and quote the reference numbers on the component pages.

Argos Ltd, 489-499 Avebury Boulevard, Central Milton Keynes, MK9 2NW

Athina - 1000 Base Unit

Assembly Instructions - Please keep for future reference

608/0811

608/0938

608/0873

608/0990

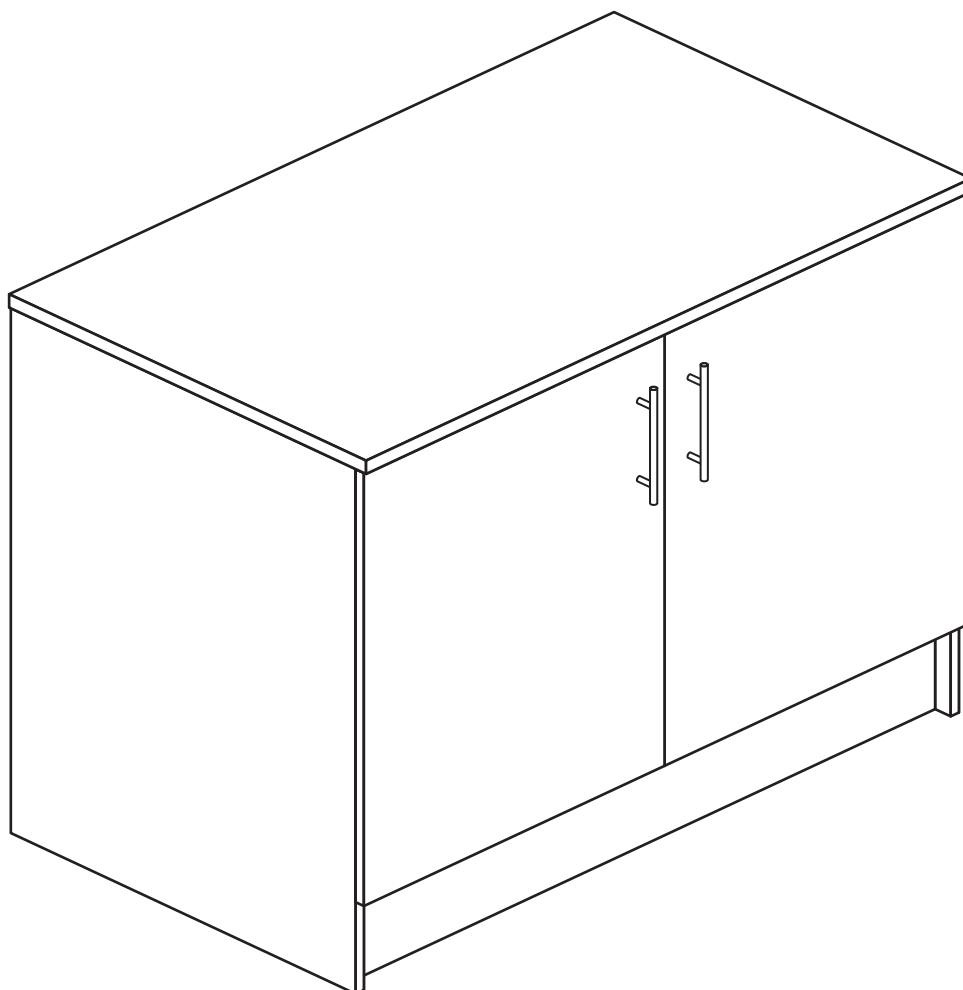

Dimensions

Width - 100cm

Depth - 59cm

Height - 89.5cm



**MADE IN
BRITAIN**

Important - Please read these instructions fully before starting assembly

If you need help or have damaged or missing parts, call the **Customer Helpline: 08456 400800**



Safety and Care Advice

Important - Please read these instructions fully before starting assembly

- **Warning:** This unit weighs approximately 42kgs. Please lift with care.

- Check you have all the components and tools listed on pages 2 and 3.

- Remove all fittings from the plastic bags and separate them into their groups.

- Keep children and animals away from the work area, small parts could choke if swallowed.

- Make sure you have enough space to layout the parts before starting.

- Do not stand or put weight on the product, this could cause damage.

- Assemble the item as close to its final position (in the same room) as possible.

- Assemble on a soft level surface to avoid damaging the unit or your floor (use opened out unit carton).



- We do not recommend the use of power drill/drivers **for inserting screws**, as this could damage the unit. Only use hand screwdrivers.

- **Safety note:** It is recommended that this unit is secured to a wall using the bracket supplied.

- Dispose of all packaging carefully and responsibly.

Care and maintenance

- Only clean using a damp cloth and mild detergent, do not use bleach or abrasive cleaners.

- From time to time check that there are no loose screws on this unit.

- This product should not be discarded with household waste. Take to your local authority waste disposal centre.

Note: If required the next page can be cut out and used as reference throughout the assembly. Keep this page with these instructions for future reference.

Components - Panels

If you have damaged or missing components, call the **Customer Helpline: 08456 400800** quoting the reference numbers below

Please check you have all the panels listed below

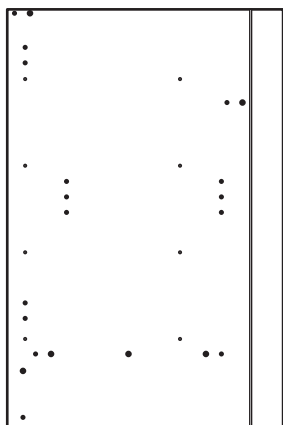

1 Left Side (D0315A)
(870 X 570mm)

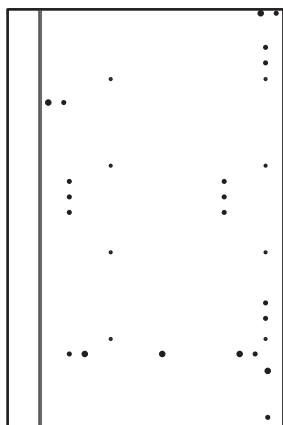

2 Right Side (D0316A)
(870 x 570mm)



3 Top (D0339A)
(1000 x 590mm)

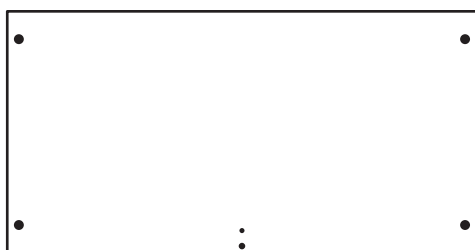

4 Base (D0323A)
(970 X 499mm)



5 Shelf (D0324A)
(969 X 427mm)



6 Rail (D0321A)
(970 x 60mm) x 2



7 Plinth (D0322A)
(970 x 150mm)



8 Munting (D0324A)
(689 x 60mm)

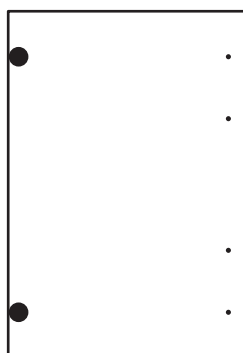

9 Door (D0317A)
(716 x 497mm) x 2



10 Back (X740)
(980 x 533mm)











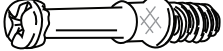

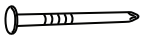
Components - Fittings

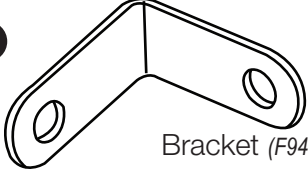
If you have damaged or missing components, call the **Customer Helpline: 08456 400800** quoting the reference numbers below

Please check you have all the fittings listed below

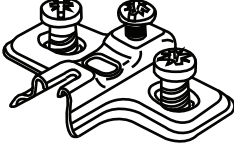
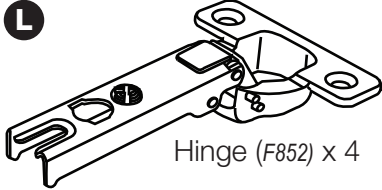
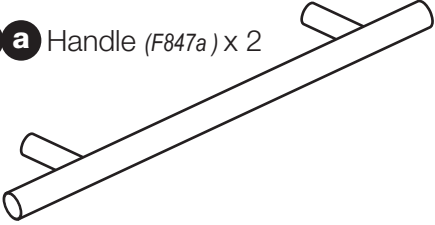
Note: The quantities below are the correct amount to complete the assembly. In some cases more fittings may be supplied than are required.

| | | |
|--|---|--|
| <p>A </p> <p>Wooden dowel (F22) x 14</p> | <p>B </p> <p>Metal dowel (F901) x 10</p> | <p>C </p> <p>Large locking nut (F900) x 10</p> |
| <p>D </p> <p>Nail (F51) x 14</p> | <p>E </p> <p>Shelf support (F110) x 4</p> | <p>F </p> <p>Bracket (F945) x 4</p> |
| <p>G </p> <p>25mm Screw (F50) x 4</p> | <p>H </p> <p>13mm Screw (F79) x 6</p> | <p>I </p> <p>13mm Screw (F63) x 8</p> |
| <p>J </p> <p>Door Buffer (F137) x 4</p> | <p>K </p> <p>Hinge Plate (F853) x 4</p> | <p>L </p> <p>Hinge (F852) x 4</p> |
| <p>M a </p> <p>Handle (F847a) x 2</p> | <p>M b </p> <p>Handle Screw (F847b) x 4</p> | <p>N </p> <p>40mm Screw (F910) x 2</p> |

Tools required

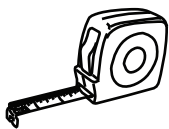

Rule



Cross-head screwdriver



Scissors



Hammer



Eye protection (when using a hammer or drill)



Electric drill

Ruler - Use this ruler to help correctly identify the screws

mm 10 20 30 40 50 60 70 80 90 100 110 120 130 140 150 160 170

Assembly Instructions

If you have damaged or missing components, call the
Customer Helpline: 08456 400800 quoting the reference
numbers below

Step 1

Fit 2 brackets to the left side

Fit a bracket **F** to the left side **1**, 100mm in from the back edge, see diagram.

Fit another bracket **F** to the left side **1**, 100mm down from the top edge, see diagram.

Secure each bracket using screw **H**.

Note: The brackets must be flush with the edges of the panel.

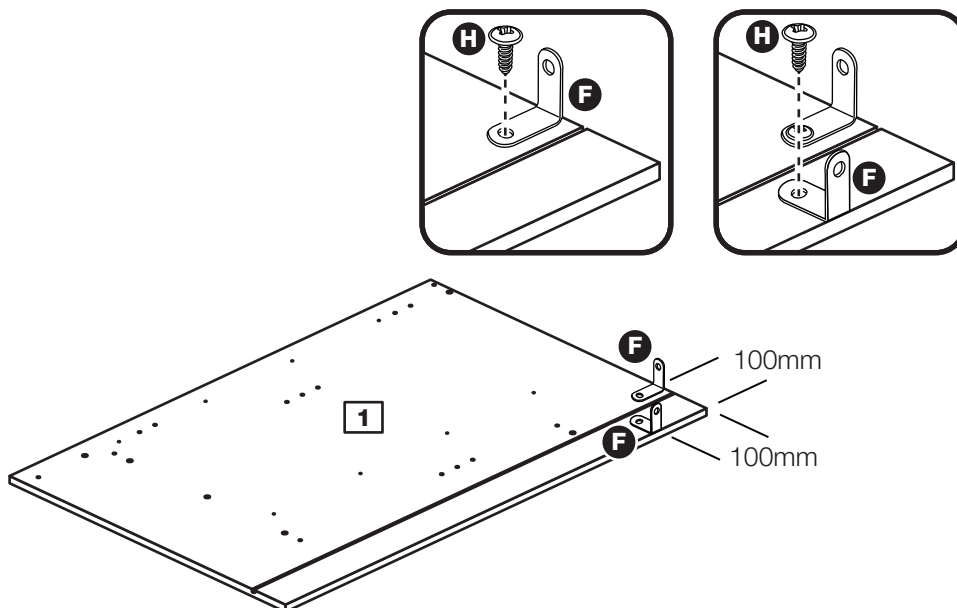

Step 2

Prepare the left side

a: Fit 2 hinge plates **K** onto the left side **1**, making sure that the slot is facing towards the front edge.

b: Screw 5 metal dowels **B** into the holes shown on the left side **1**.

Note: Tighten metal dowels up fully against the panels.

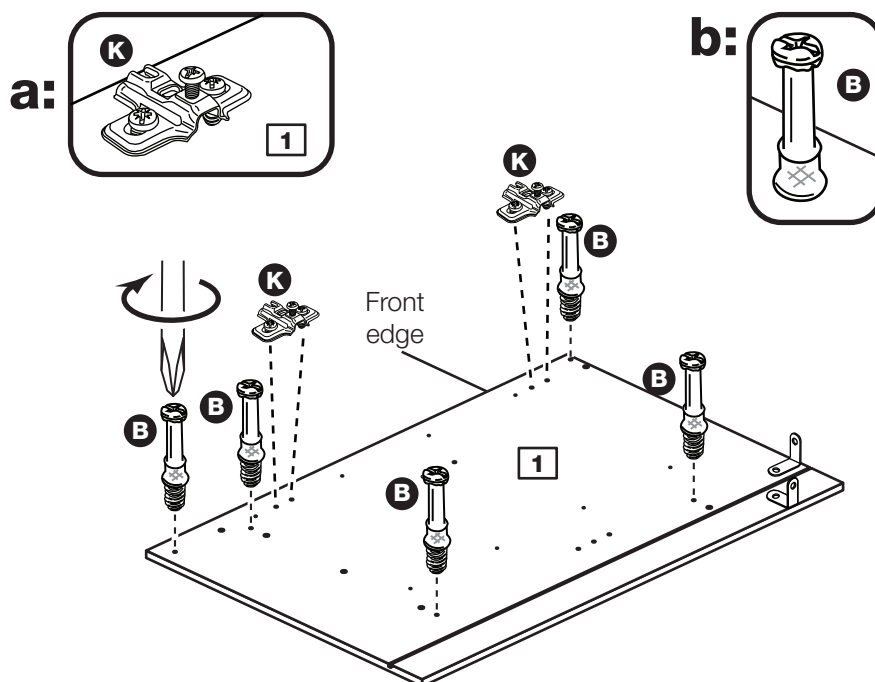

Assembly Instructions

Step 3

Fit 2 brackets to the right side

Fit a bracket **F** to the right side **2**, 100mm down from the back edge, see diagram.

Fit another bracket **F** to the right side **2**, 100mm down from the top edge, see diagram.

Secure each bracket using screw **H**.

Note: The brackets must be flush with the edges of the panel.

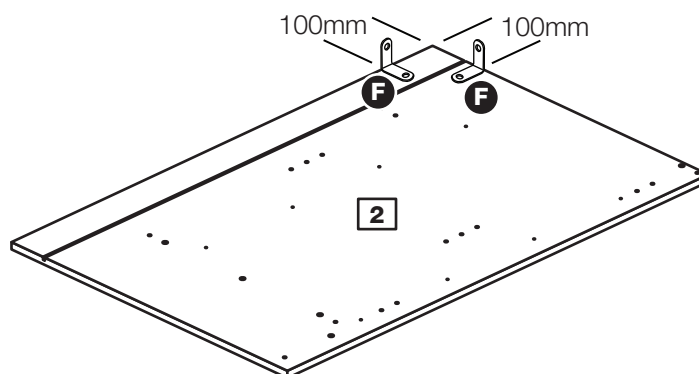
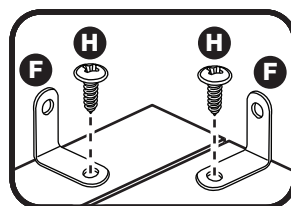

Step 4

Prepare the right side

a: Fit 2 hinge plates **K** onto the right side **2**, making sure that the slot is facing towards the front edge.

b: Screw 5 metal dowels **B** into the holes shown on the right side **2**.

Note: Tighten metal dowels up fully against the panels.

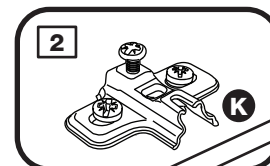
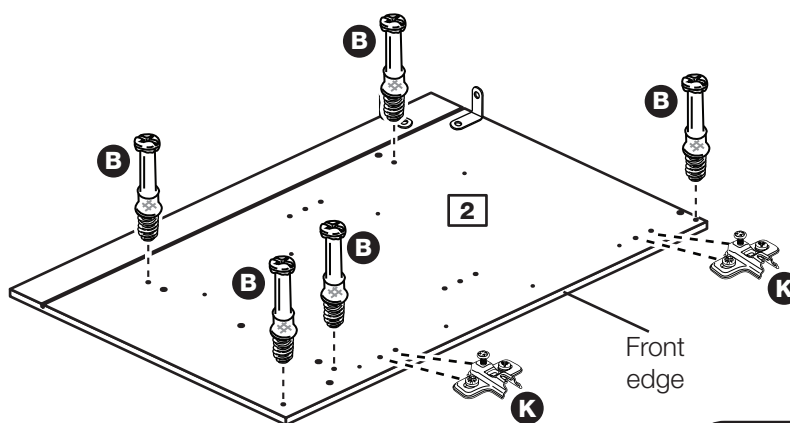

Assembly Instructions

Step 5

Prepare the base

Insert 4 large locking nuts **C** into the base **4** as shown.

Note: Arrow on locking nut **must** point towards hole in edge of panel.

Tap 6 wooden dowels **A** into the base **4** as shown.

Note: Wooden dowels **must not** stick out from the edge by more than 10mm or they may damage other panels.

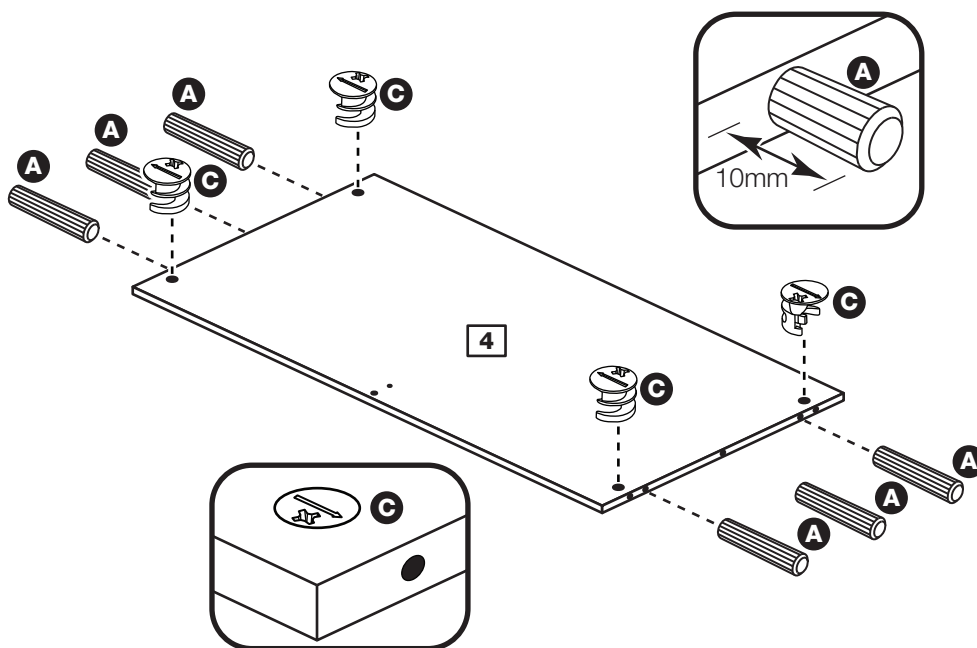

Step 6

Fit the base to the right side

Push the base **4** onto the right side **2**.

Use a screwdriver to tighten the 2 large locking nuts **C** fitted to the base **4**.

Note: Turn the large locking nuts **C** as far as they will go - more than 1/2 a turn.

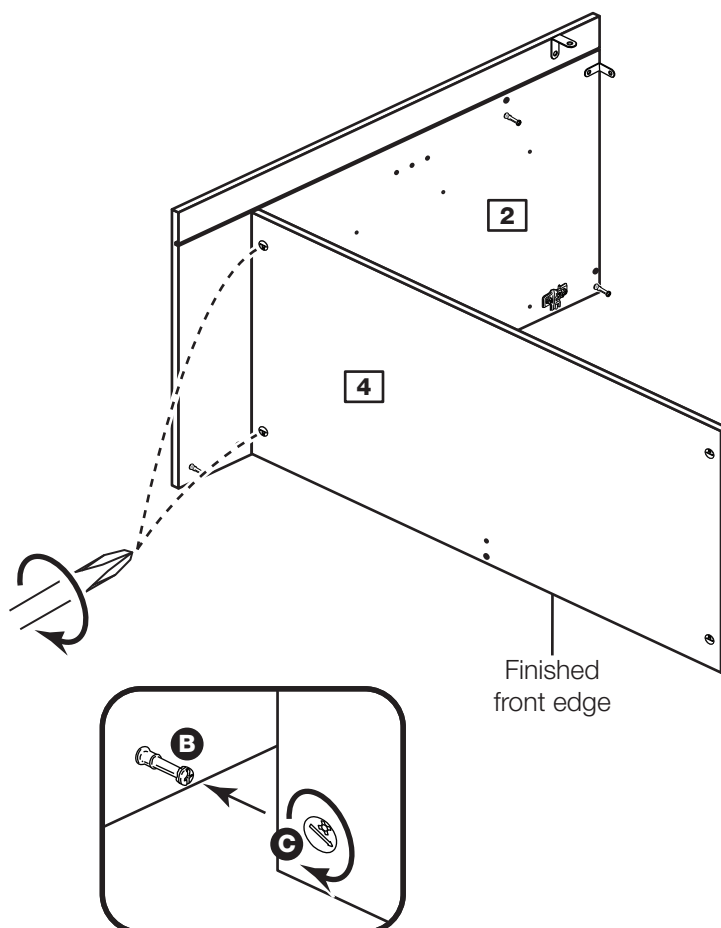

Assembly Instructions

Step 7

Prepare the 2 rails and munting

Insert 2 large locking nuts **C** and 2 wooden dowels **A** into each of the 2 rails **6**.

Tap 2 wooden dowels **A** into the munting **8**.

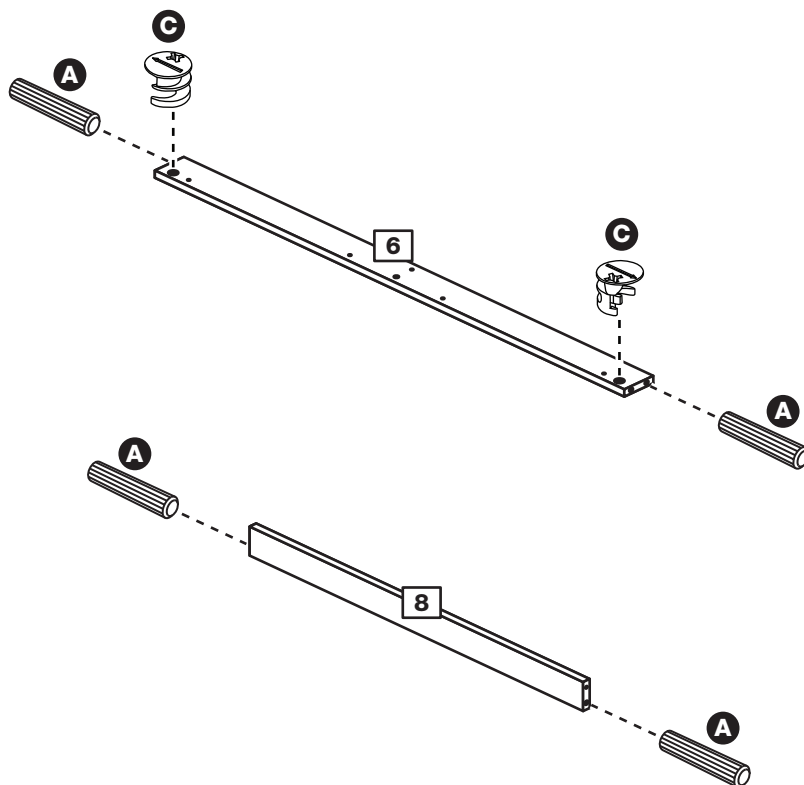

Step 8

Fit a rail to the right side

Push one of the rails **6** onto the right side **2** as shown.

Use a screwdriver to tighten the large locking nut **C**.

Note: Turn the large locking nuts **C** as far as they will go - more than 1/2 a turn.

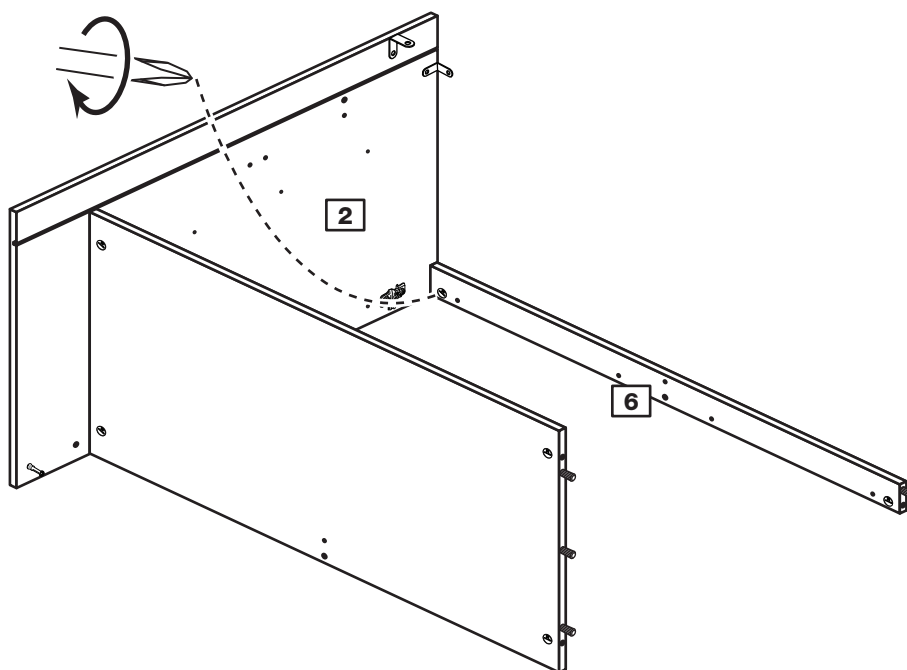

Assembly Instructions

Step 9

Fit the munting

Fit the munting **8** to the rail **6** and base **4** and secure using 2 screws **N**.

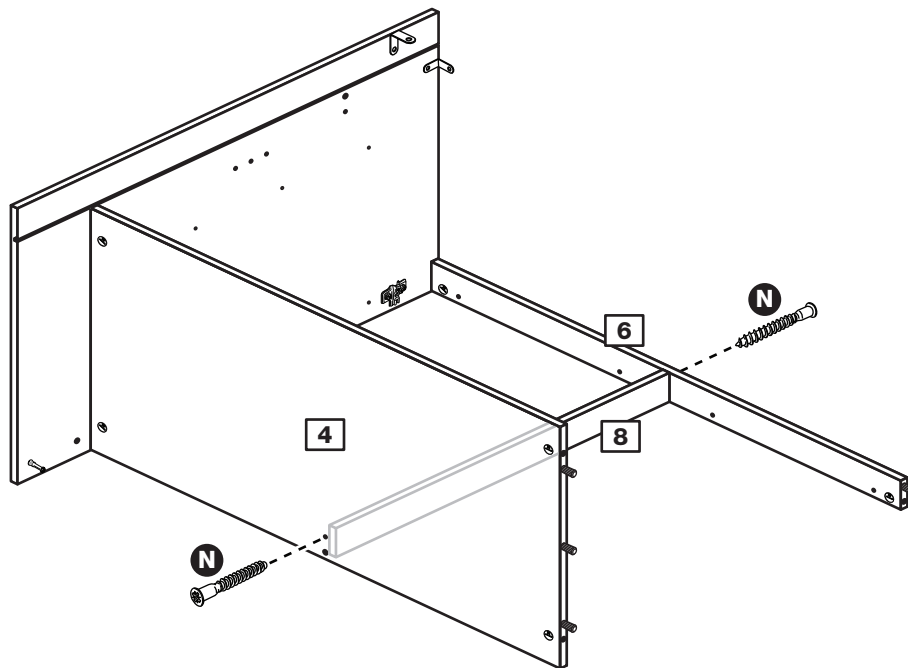

Step 10

Prepare the plinth

Insert 2 large locking nuts **C** and 2 wooden dowels **A** into the plinth **7**.

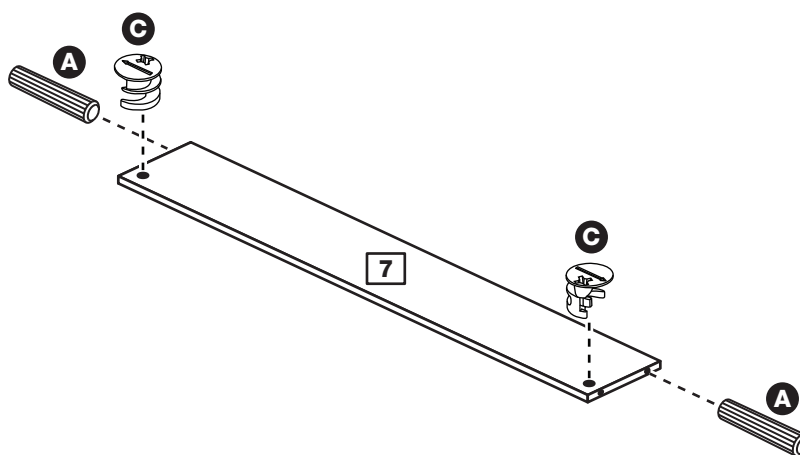

Assembly Instructions

Step 11

Fit the rail and plinth

Push the rail **6** and plinth **7** onto the right side **2** as shown.

Use a screwdriver to tighten the 2 large locking nuts **C** fitted to the 2 panels, as shown.

Note: Turn the large locking nuts **C** as far as they will go - more than 1/2 a turn.

Note: Support the rail **6** until the left side has been fitted in the next stage.

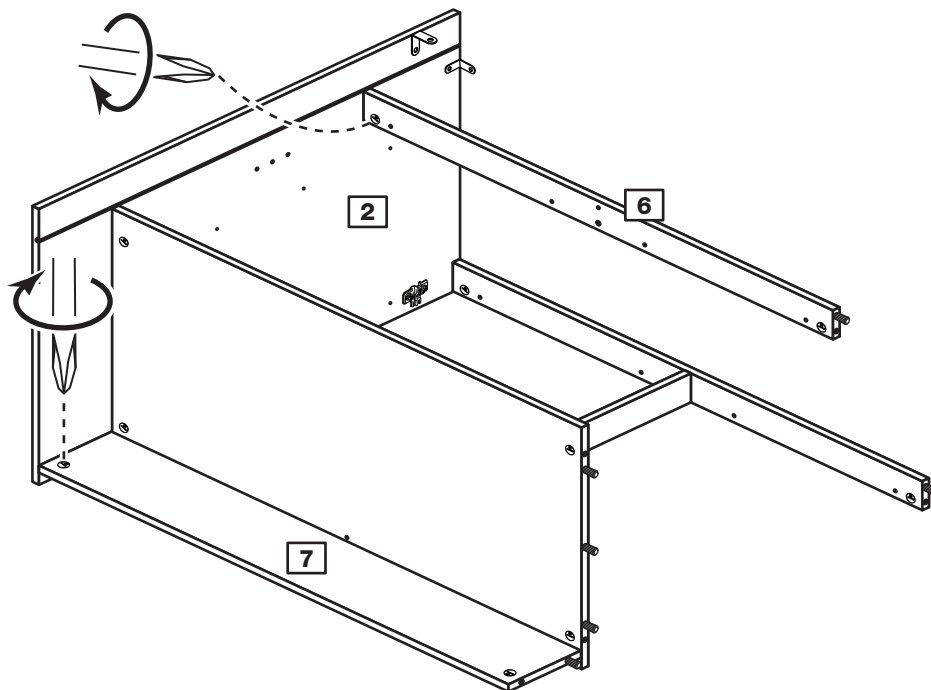

Step 12

Fit the left side

Push the left side **1** onto the assembly.

Use a screwdriver to tighten the 5 large locking nuts **C** fitted to the base **4**, rails **6** and plinth **7**.

Note: Turn the large locking nuts **C** as far as they will go - more than 1/2 a turn.

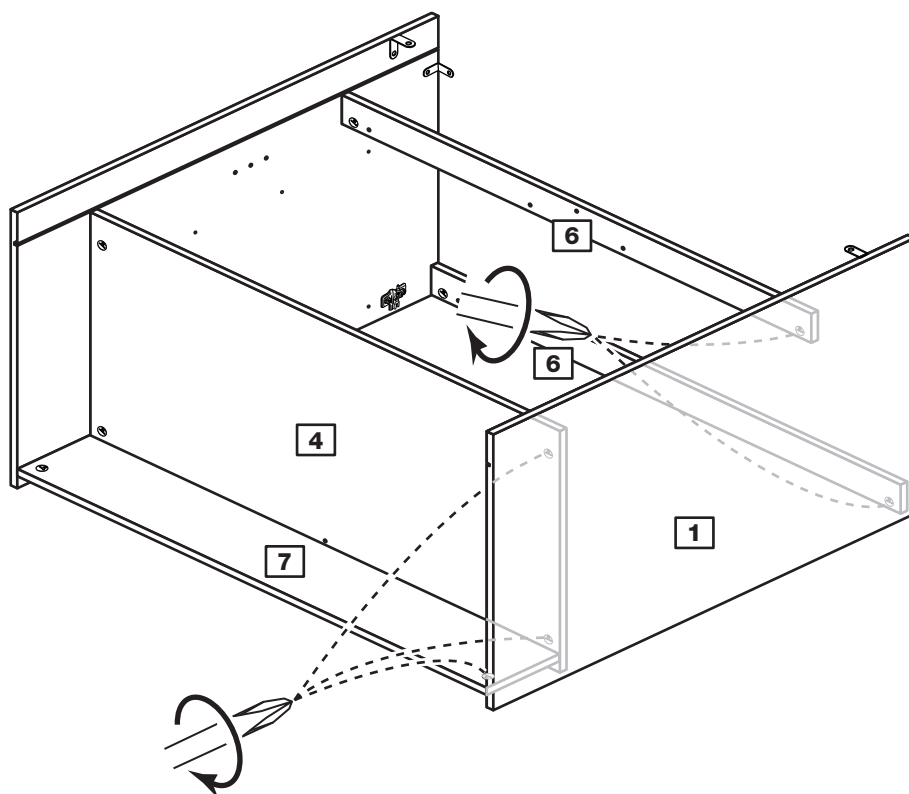

Assembly Instructions

Step 13

Fit the back

a: Square up the unit by making sure that measurement **x to x** equals **y to y**.

b: Slide the back **10** into the grooves along the left **1** and right **2** sides, as shown.

c: Secure the back **10** by tapping 7 nails **D** down into the back edge of the base **4** and 7 nails **D** into the back edge of the rail **6**.

Stand the unit up for the next stage.

a: The measurement from top corner X to bottom corner X must be equal to the measurement from top corner Y to bottom corner Y

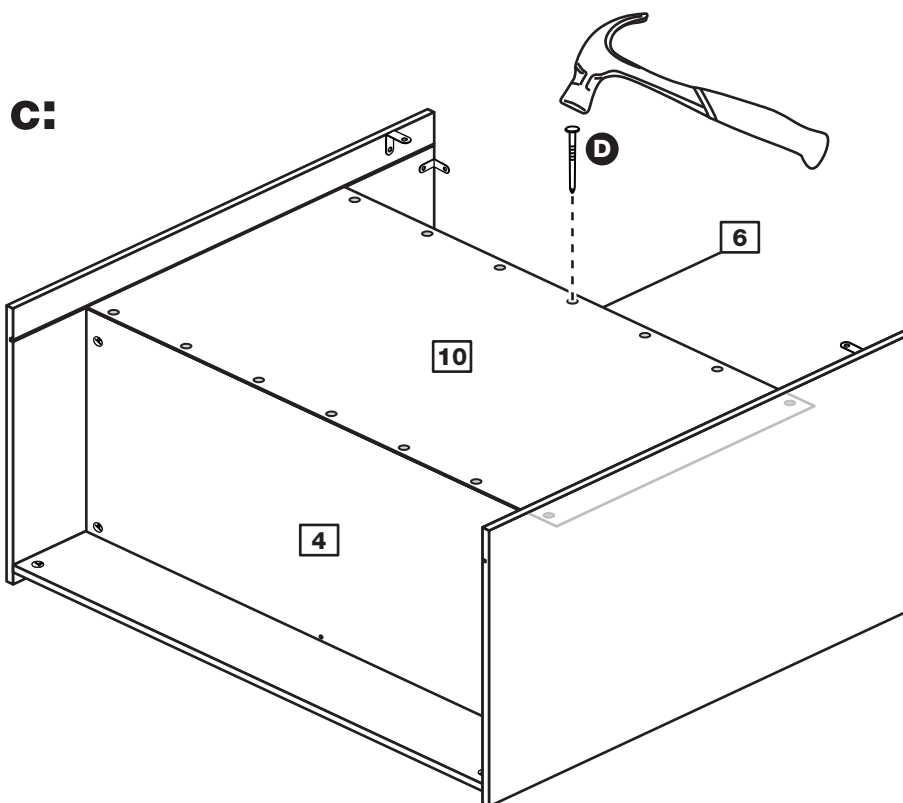
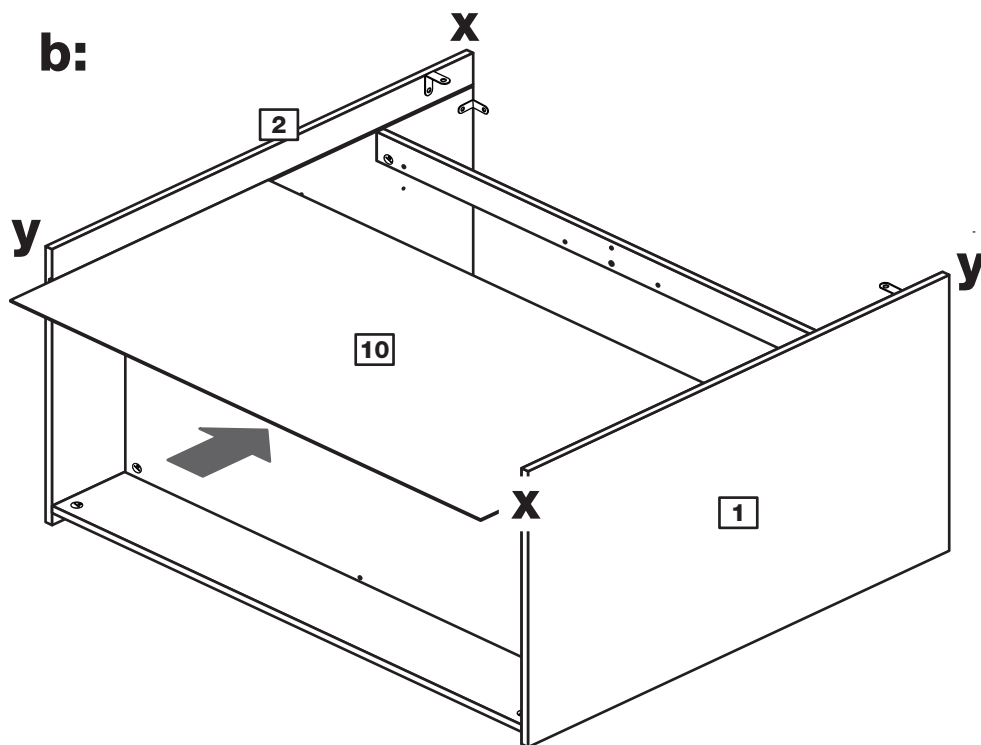

Assembly Instructions

Step 14

Fit the top

Position the top **3** onto the unit, making sure that the back edge is flush with the back edge of the sides **1** and **2**.

Secure the top **3** using screw **H** through the 2 brackets **F** fitted at the top edge of the side panels **1** and **2**.

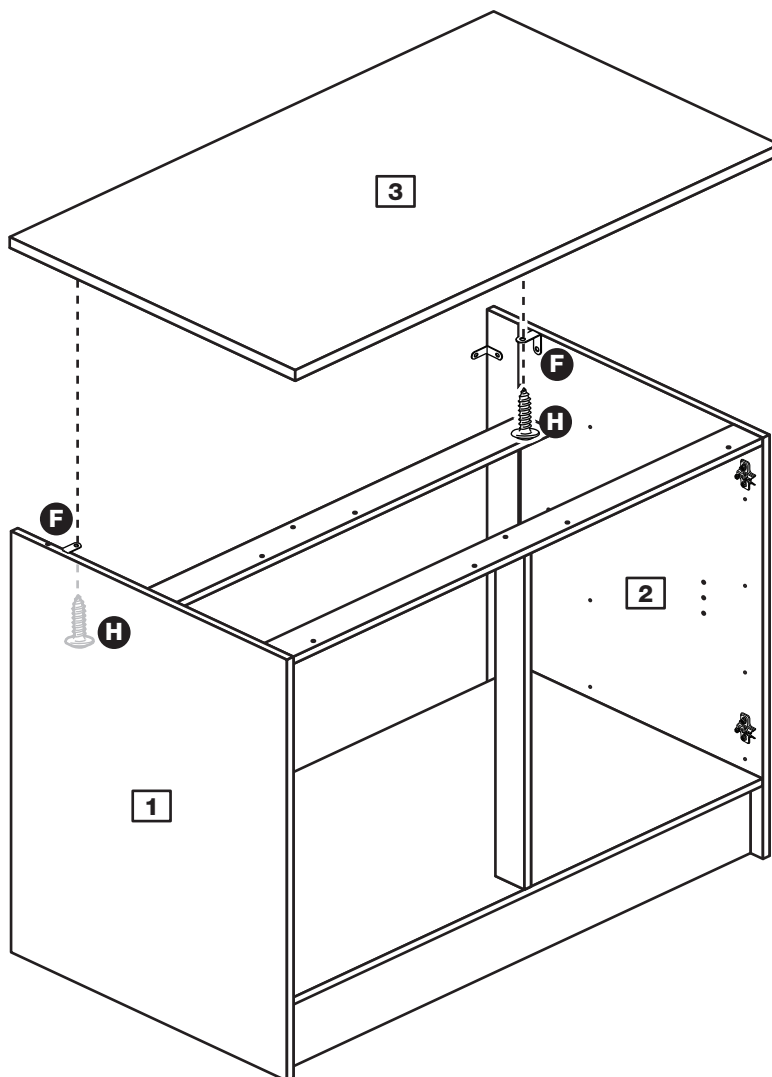

Step 15

Secure the front of the top

To secure the front of the top **3**, screw up through the 4 holes in the rail **6** at the front of the unit using screws **G**.

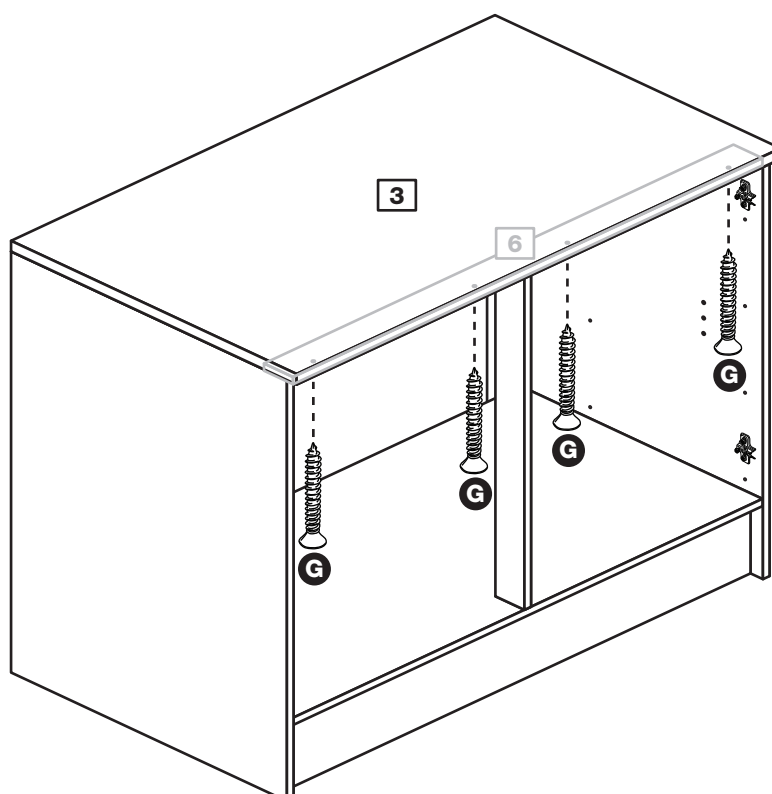

Assembly Instructions

Step 16

Secure the unit to the wall

Using the brackets **F** fitted to the back edge of the sides **1** and **2** screw the unit to the wall.

Fixings are not supplied as they will need to suit the wall type, and the length of screw will depend on the distance of the back of the Unit to the wall.



Warning: Take care when drilling the wall that you do not drill into any pipes, wires etc. If in doubt, consult an expert.

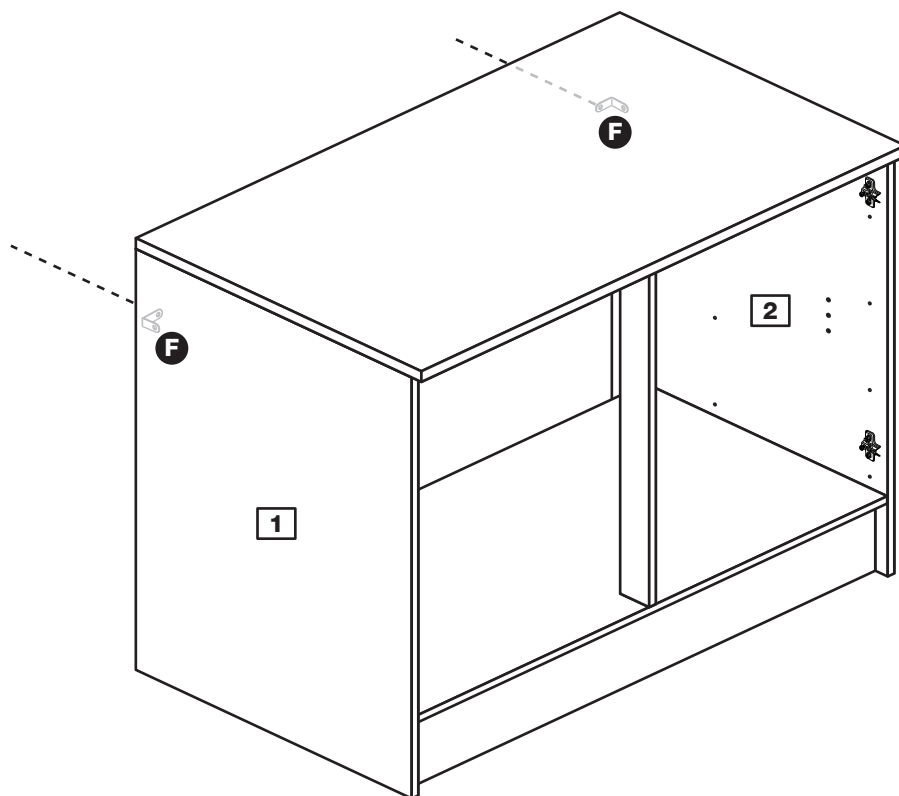

Step 17

Fit the shelf studs

Push 4 shelf studs **E** into the holes in the side panels **1** and **2** at the desired height.

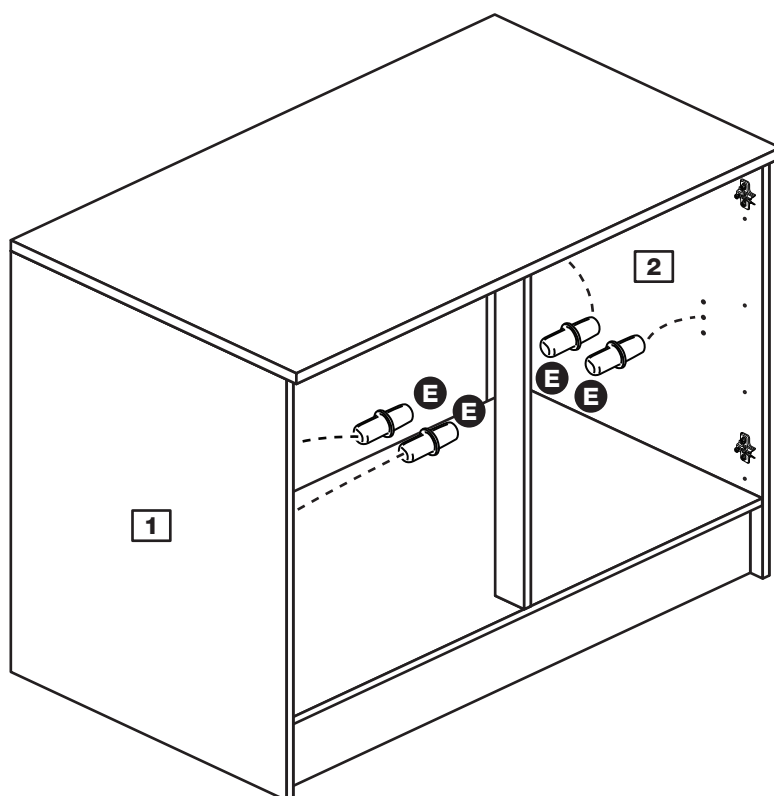

Assembly Instructions

Step 18

Fit the shelf

Manouvre the shelf **5** into the unit onto the shelf studs **E**.

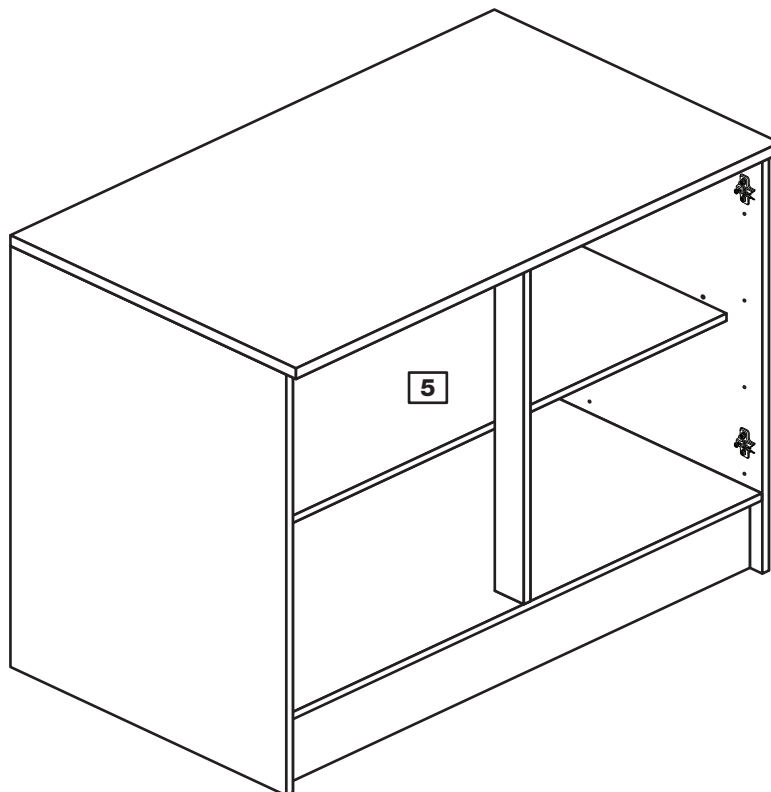

Step 19

Prepare the 2 doors

Push fit the 2 hinges **L** into the door **9**.

Secure each hinge with 2 screws **I**.

Note: Before securing with the screws, make sure that the hinges are positioned at 90 degrees with the front edge of the door.

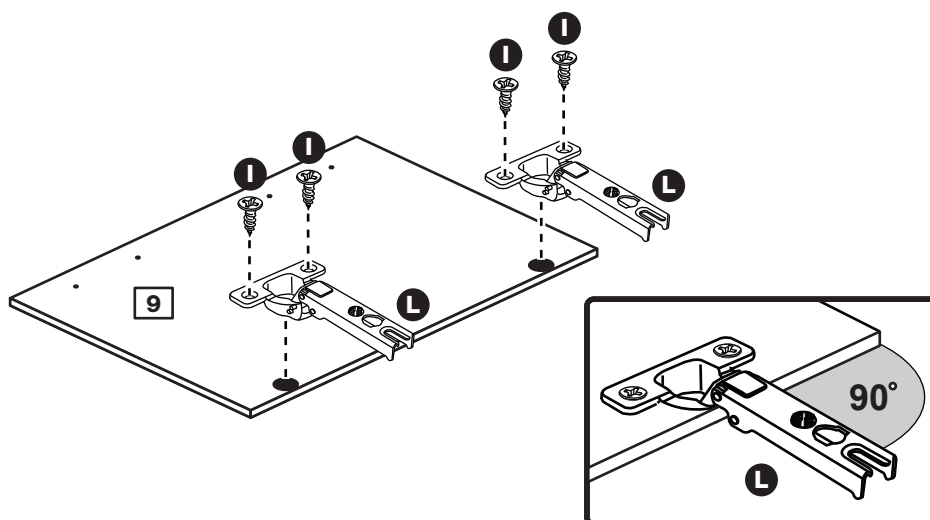

Assembly Instructions

Step 20

Drill the handle holes in the door

Important: Please follow these instructions carefully.

Lay the doors **9** down onto a smooth surface.

Important: Check that the holes and hinges are in the same place as the diagrams.

Note: We recommend the use of a small piece of waste wood, placed behind the hole while drilling, to reduce the possibility of any breakout.

Using the pilot hole in the rear face of the door **9**, drill through the holes indicated opposite, using a 2.5mm diameter drill.

Turn the door **9** over and open out the 2.5mm holes that you have just drilled by drilling back through them with a 5mm drill.

This will be the left door

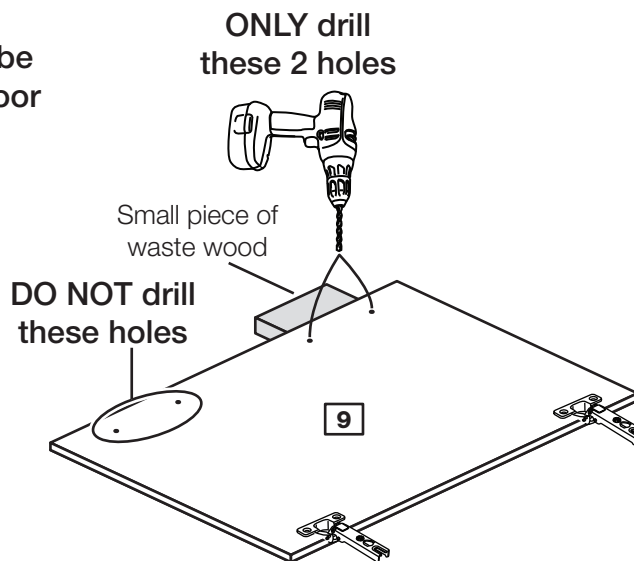

This will be the right door

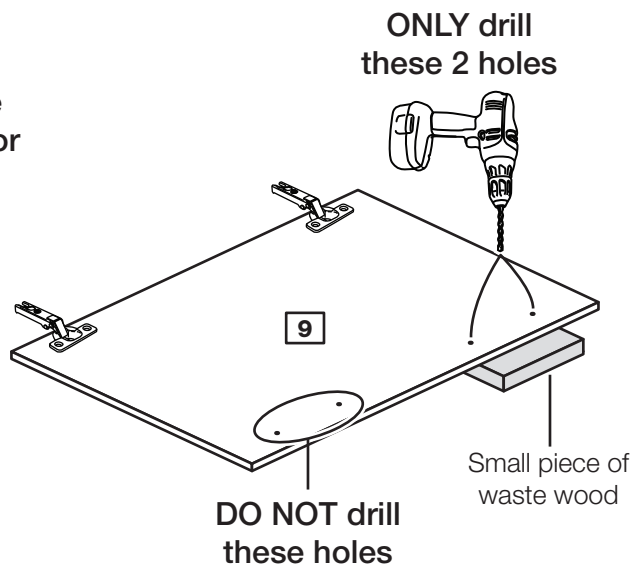

Assembly Instructions

Step 21

Fit doors and handles

2 people are needed here

Note: The easiest way to attach the door **9** is to fit the top hinge first, then align and fit the other hinges.

a: Push the hinge **L** onto the front part of the hinge plate **K**.

b: Keep the hinge **L** FLAT against the hinge plate **K** as you slide it across as far as it will go. Tighten screw A.

c: The hinge **L** must be flat against the hinge plate **K** prior to any adjustment.

d: The hinge **L** must NOT be AT AN ANGLE to the hinge plate **K** when assembled. This would indicate that the recess at the bottom of screw B had not located in the slot in the hinge plate and the hinge would not be secure. Remove the hinge from the hinge plate and then re-assemble being careful to follow instructions a-c.

e: Attach a handle **M a** to the door **9** using 2 screws **M b**.

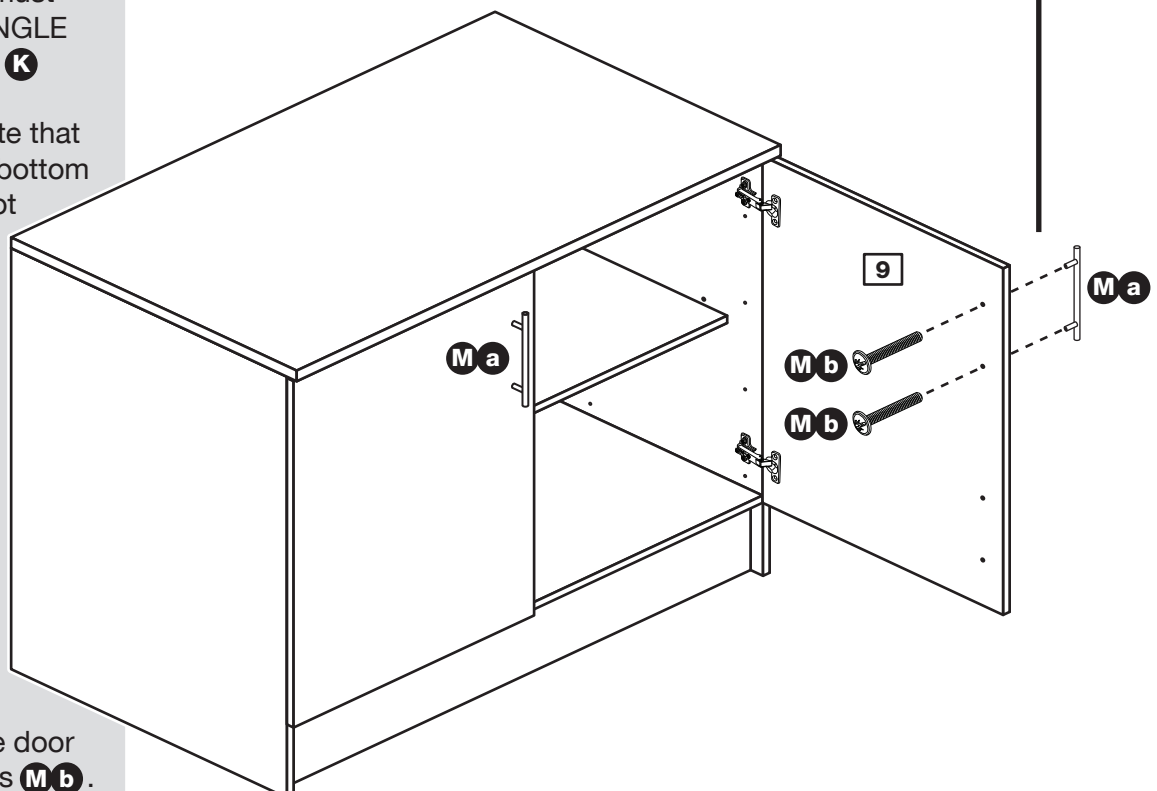
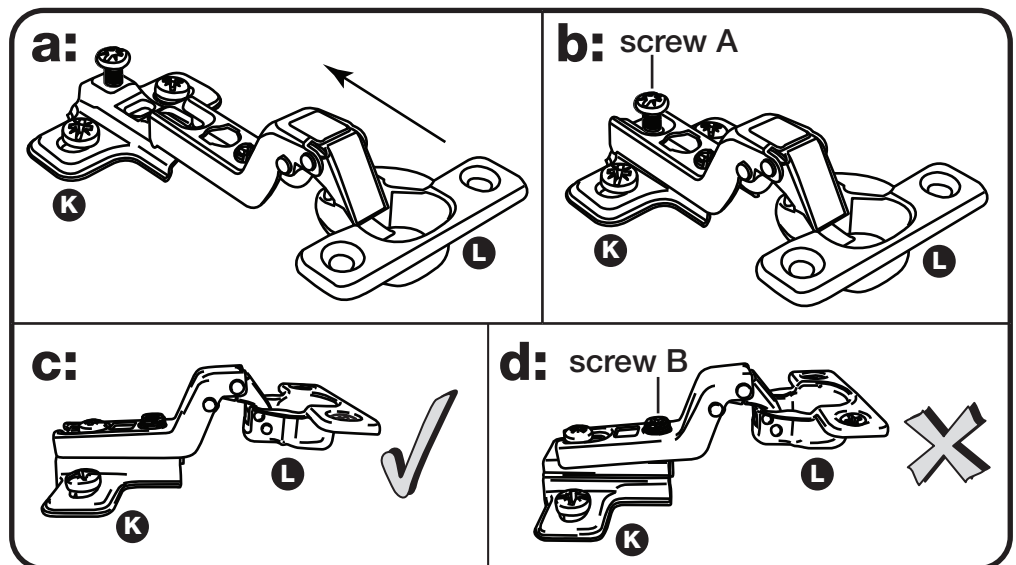

Assembly Instructions

Step 22

Adjust the doors if needed

a: Height adjustment.

Loosen screws A on hinge plates and move door up or down as required.
Retighten screw A.

b: Forward and Back adjustment.

Loosen screw B on hinge plate and move door in or out as required.
Retighten screw B.

c: Sideways adjustment.

To move door 'out' loosen screw C.
To move door 'in' tighten screw C

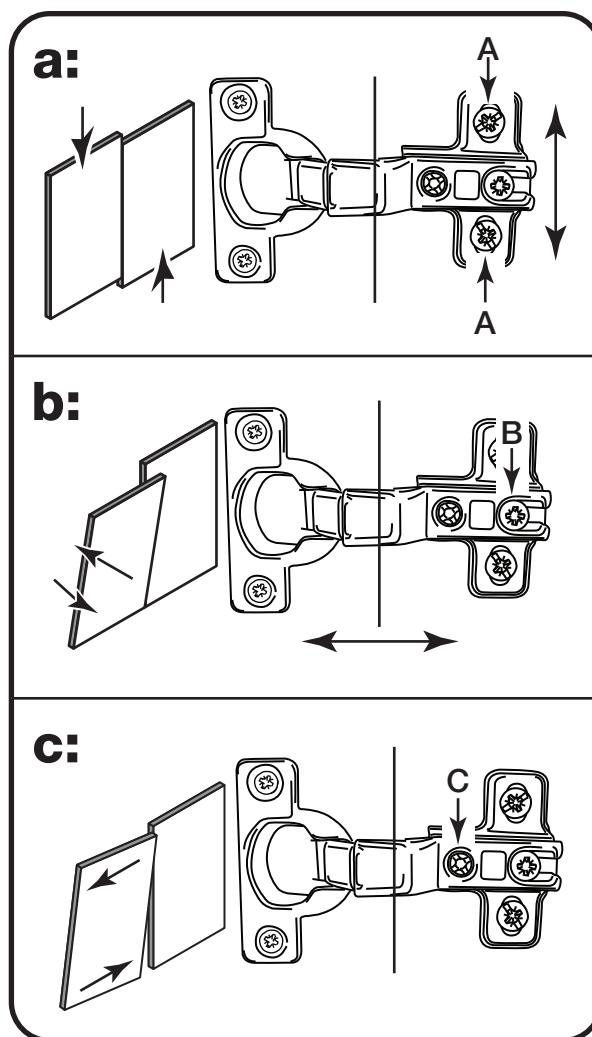

Step 23

Fit the door buffers to both doors

Stick a door buffer **J** onto each corner of the door **9** so that they hit the edge of the side panel when the door is closed.

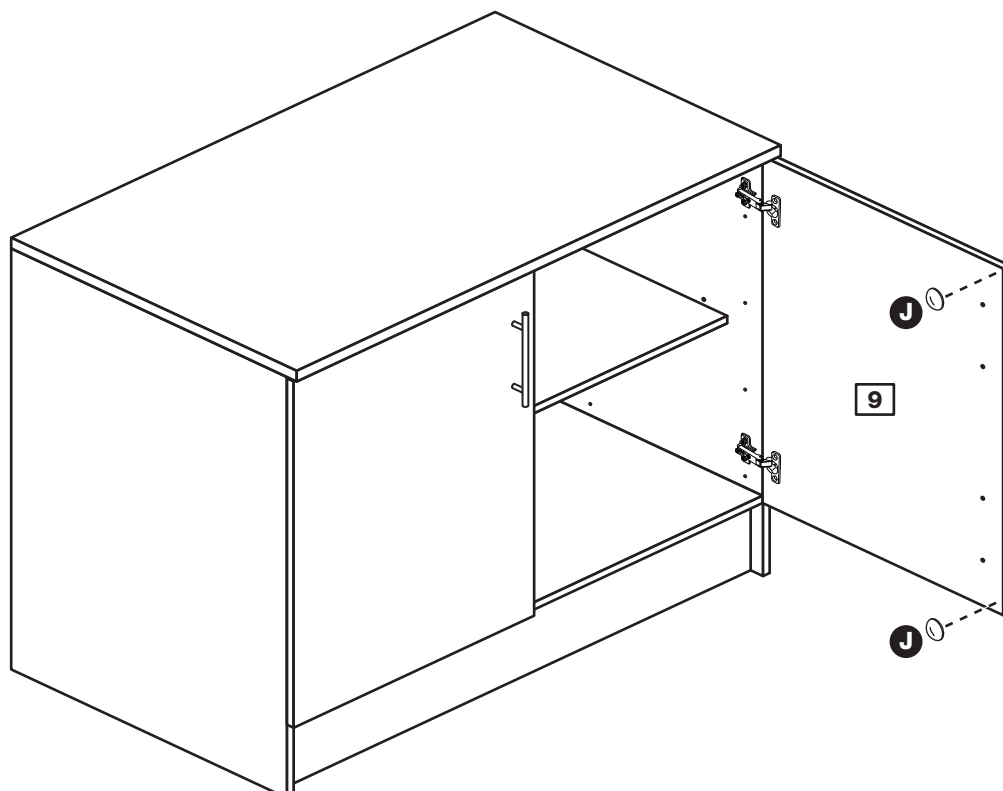

Assembly Instructions

Step 24

Assembly is complete



Warning: The unit is heavy. Lift with care.

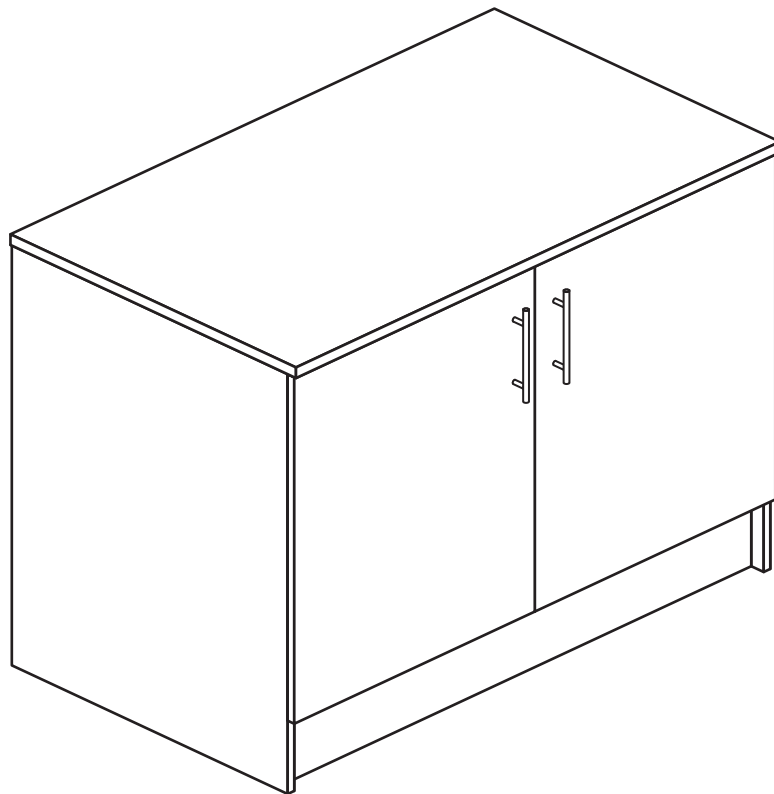

If you need help or have damaged or missing parts, call the **Customer Helpline: 08456 400800** and quote the reference numbers on the component pages.

Argos Ltd, 489-499 Avebury Boulevard, Central Milton Keynes, MK9 2NW

Athina - 1000 Base Unit

Assembly Instructions - Please keep for future reference

608/0811

608/0938

608/0873

608/0990

608/2981

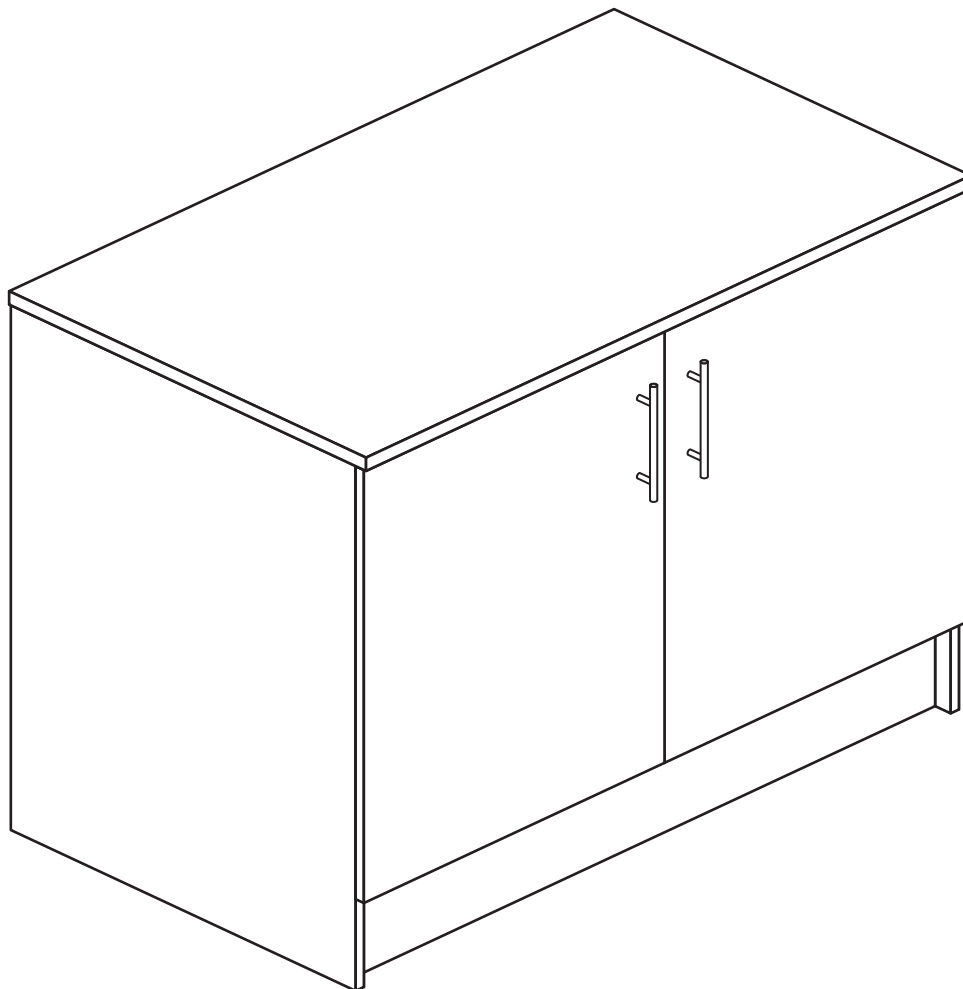

Dimensions

Width - 100cm

Depth - 59cm

Height - 89.5cm



**MADE IN
BRITAIN**

Important - Please read these instructions fully before starting assembly

If you need help or have damaged or missing parts, call the **Customer Helpline: 08456 400800**



Safety and Care Advice

Important - Please read these instructions fully before starting assembly

- **Warning:** This unit weighs approximately 42kgs. Please lift with care.

- Check you have all the components and tools listed on pages 2 and 3.

- Remove all fittings from the plastic bags and separate them into their groups.

- Keep children and animals away from the work area, small parts could choke if swallowed.

- Make sure you have enough space to layout the parts before starting.

- Do not stand or put weight on the product, this could cause damage.

- Assemble the item as close to its final position (in the same room) as possible.

- Assemble on a soft level surface to avoid damaging the unit or your floor (use opened out unit carton).



- We do not recommend the use of power drill/drivers **for inserting screws**, as this could damage the unit. Only use hand screwdrivers.

- **Safety note:** It is recommended that this unit is secured to a wall using the brackets supplied.

- Dispose of all packaging carefully and responsibly.

Care and maintenance

- Only clean using a damp cloth and mild detergent, do not use bleach or abrasive cleaners.

- From time to time check that there are no loose screws on this unit.

- This product should not be discarded with household waste. Take to your local authority waste disposal centre.

Note: If required the next page can be cut out and used as reference throughout the assembly. Keep this page with these instructions for future reference.

Components - Panels

If you have damaged or missing components, call the **Customer Helpline: 08456 400800** quoting the reference numbers below

Please check you have all the panels listed below

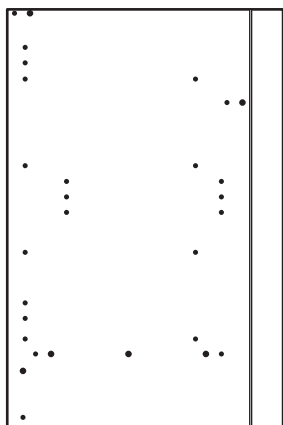

1 Left Side (D0315B)
(870 X 570mm)

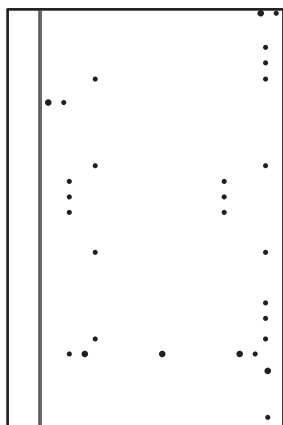

2 Right Side (D0316B)
(870 x 570mm)



3 Top (D0339A)
(1000 x 590mm)

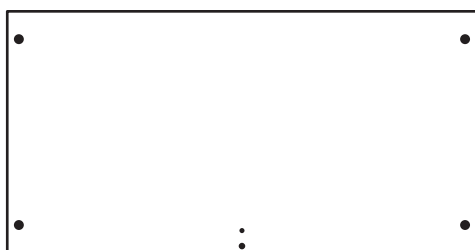

4 Base (D0323A)
(970 X 499mm)



5 Shelf (D0324A)
(969 X 427mm)



6 Rail (D0325A)
(970 x 60mm) x 2



7 Plinth (D0326A)
(970 x 150mm)



8 Munting (D0327A)
(689 x 59mm)

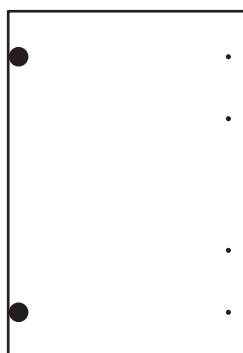

9 Door (D0317A)
(716 x 497mm) x 2



10 Back (X740)
(980 x 533mm)











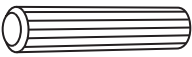
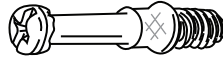

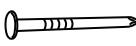
Components - Fittings

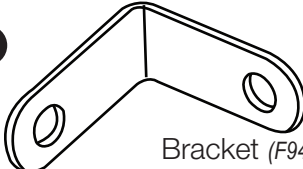
If you have damaged or missing components, call the **Customer Helpline: 08456 400800** quoting the reference numbers below

Please check you have all the fittings listed below

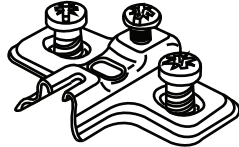
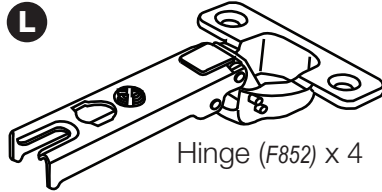
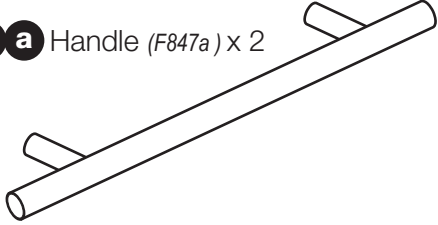
Note: The quantities below are the correct amount to complete the assembly. In some cases more fittings may be supplied than are required.

| | | |
|--|---|--|
| <p>A </p> <p>Wooden dowel (F22) x 14</p> | <p>B </p> <p>Metal dowel (F901) x 10</p> | <p>C </p> <p>Large locking nut (F900) x 10</p> |
| <p>D </p> <p>Nail (F51) x 14</p> | <p>E </p> <p>Shelf support (F110) x 4</p> | <p>F </p> <p>Bracket (F945) x 4</p> |
| <p>G </p> <p>25mm Screw (F50) x 4</p> | <p>H </p> <p>13mm Screw (F79) x 6</p> | <p>I </p> <p>13mm Screw (F63) x 8</p> |
| <p>J </p> <p>Door Buffer (F137) x 4</p> | <p>K </p> <p>Hinge Plate (F853) x 4</p> | <p>L </p> <p>Hinge (F852) x 4</p> |
| <p>M a </p> <p>Handle (F847a) x 2</p> | <p>M b </p> <p>Handle Screw (F847b) x 4</p> | <p>N </p> <p>40mm Screw (F910) x 2</p> |

Tools required

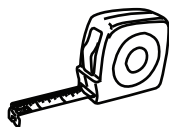

Rule



Cross-head screwdriver



Scissors



Hammer



Eye protection (when using a hammer or drill)



Electric drill

Ruler - Use this ruler to help correctly identify the screws

mm 10 20 30 40 50 60 70 80 90 100 110 120 130 140 150 160 170

Assembly Instructions

If you have damaged or missing components, call the
Customer Helpline: 08456 400800 quoting the reference
numbers below

Step 1

Fit 2 brackets to the left side

Fit a bracket **F** to the left side **1**, 100mm in from the back edge, see diagram.

Fit another bracket **F** to the left side **1**, 100mm down from the top edge, see diagram.

Secure each bracket using screw **H**.

Note: The brackets must be flush with the edges of the panel.

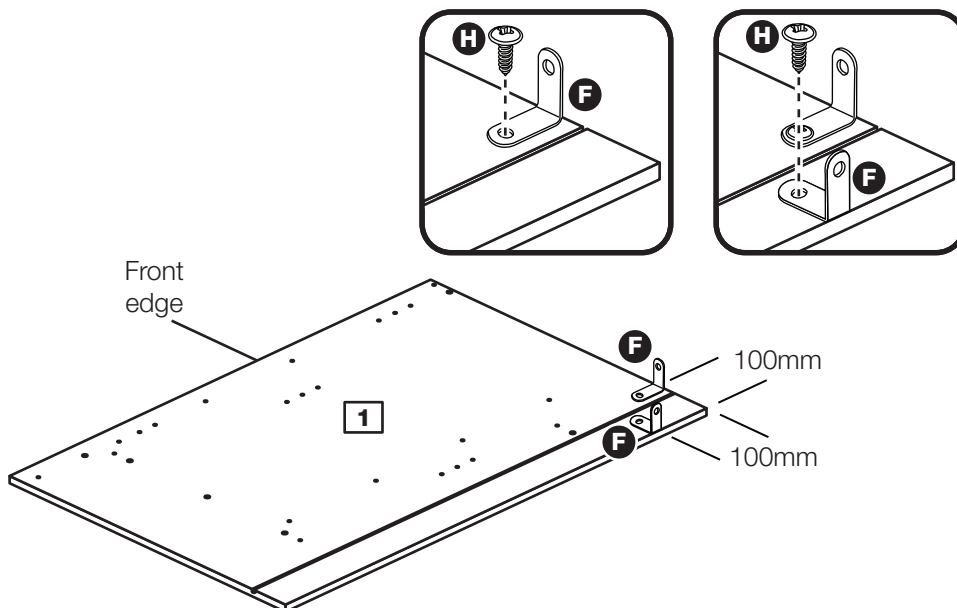

Step 2

Prepare the left side

a: Fit 2 hinge plates **K** onto the left side **1**, making sure that the slot is facing towards the front edge.

b: Screw 5 metal dowels **B** into the holes shown on the left side **1**.

Note: Tighten metal dowels up fully against the panels.

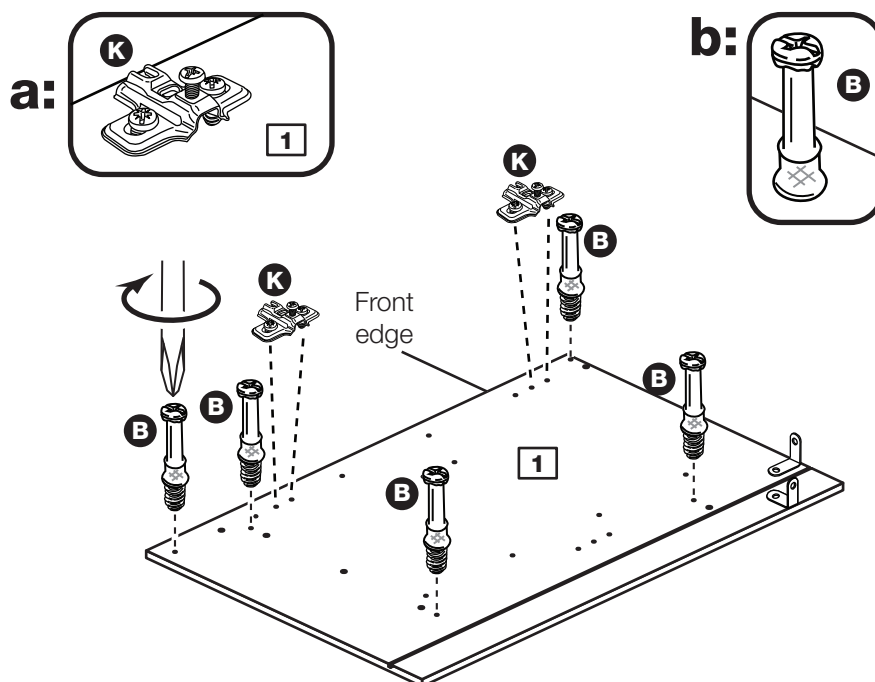

Assembly Instructions

Step 3

Fit 2 brackets to the right side

Fit a bracket **F** to the right side **2**, 100mm down from the back edge, see diagram.

Fit another bracket **F** to the right side **2**, 100mm down from the top edge, see diagram.

Secure each bracket using screw **H**.

Note: The brackets must be flush with the edges of the panel.

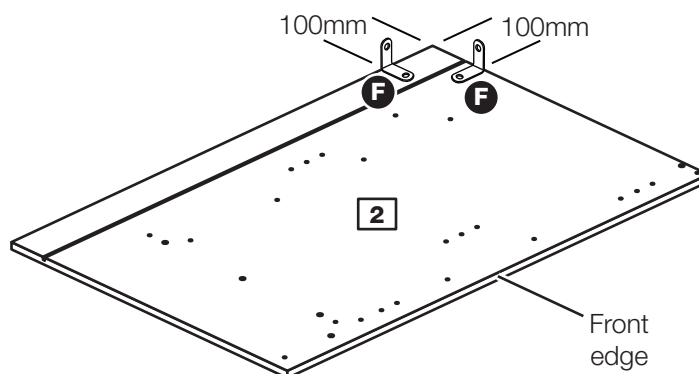
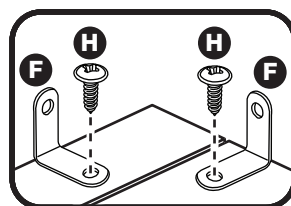

Step 4

Prepare the right side

a: Fit 2 hinge plates **K** onto the right side **2**, making sure that the slot is facing towards the front edge.

b: Screw 5 metal dowels **B** into the holes shown on the right side **2**.

Note: Tighten metal dowels up fully against the panels.

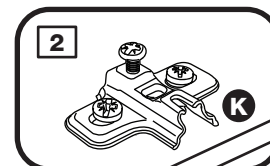
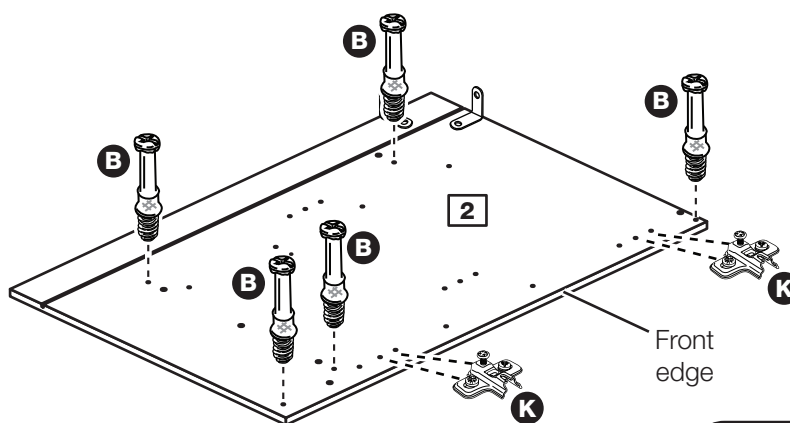

Assembly Instructions

Step 5

Prepare the base

Insert 4 large locking nuts **C** into the base **4** as shown.

Note: Arrow on locking nut **must** point towards hole in edge of panel.

Tap 6 wooden dowels **A** into the base **4** as shown.

Note: Wooden dowels **must not** stick out from the edge by more than 10mm or they may damage other panels.

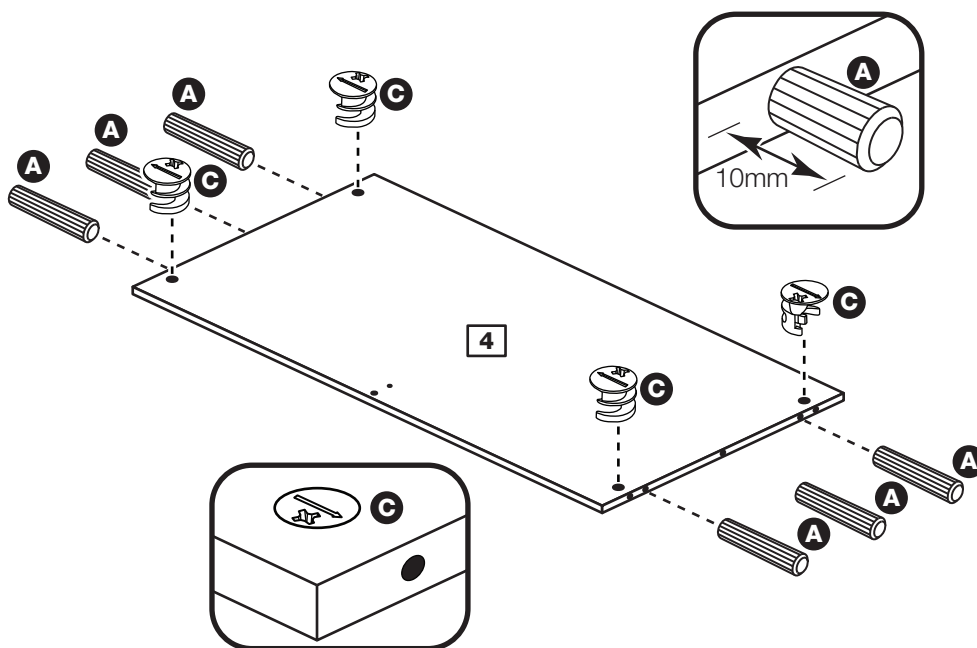

Step 6

Fit the base to the right side

Push the base **4** onto the right side **2**.

Use a screwdriver to tighten the 2 large locking nuts **C** fitted to the base **4**.

Note: Turn the large locking nuts **C** as far as they will go - more than 1/2 a turn.

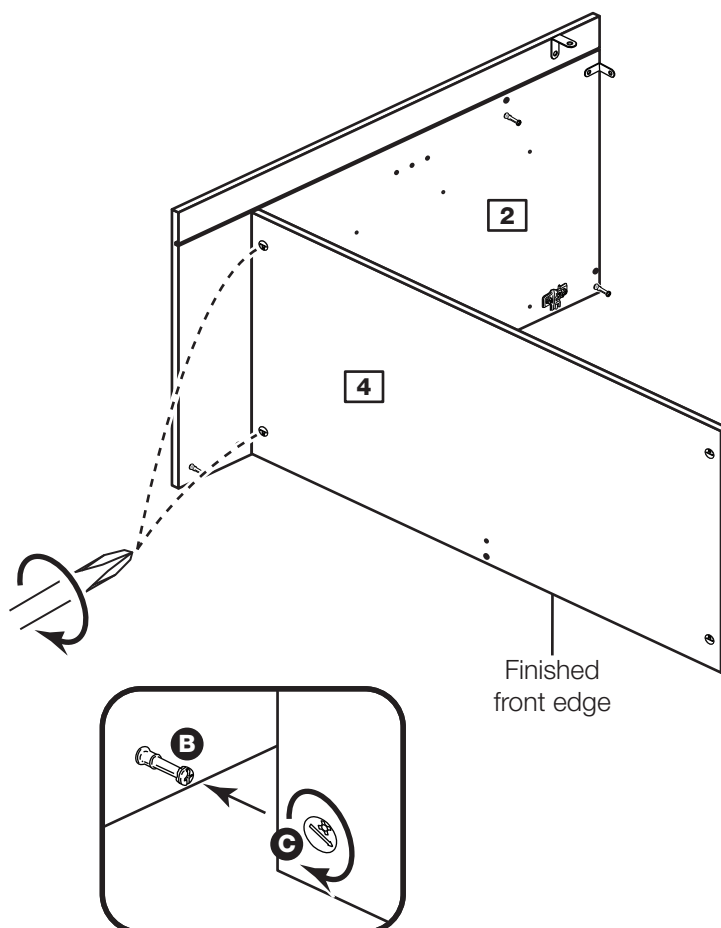

Assembly Instructions

Step 7

Prepare the 2 rails and munting

Insert 2 large locking nuts **C** and 2 wooden dowels **A** into each of the 2 rails **6**.

Tap 2 wooden dowels **A** into the munting **8**.

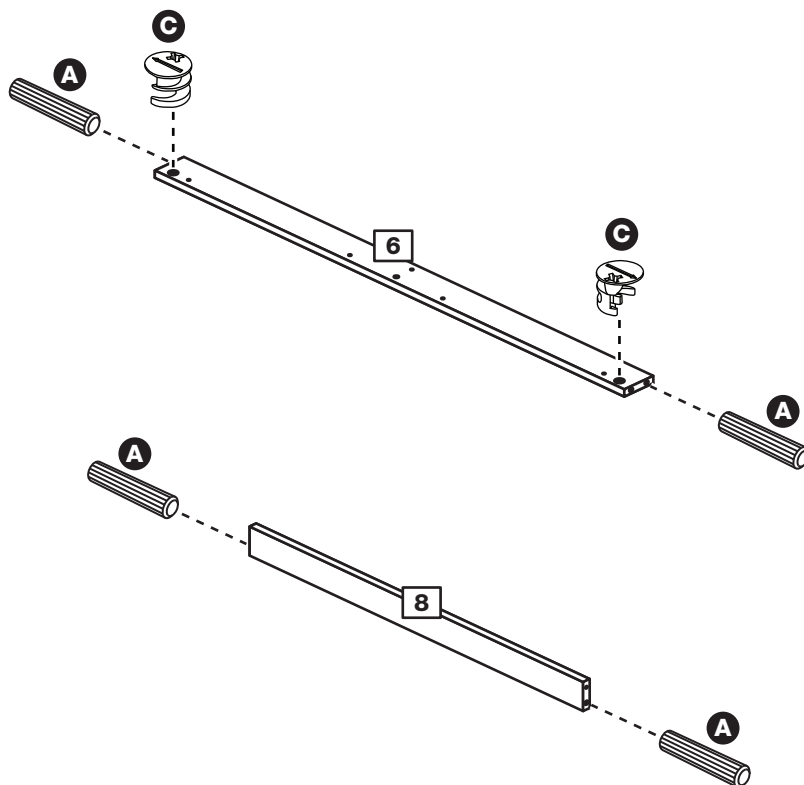

Step 8

Fit a rail to the right side

Push one of the rails **6** onto the right side **2** as shown.

Use a screwdriver to tighten the large locking nut **C**.

Note: Turn the large locking nuts **C** as far as they will go - more than 1/2 a turn.

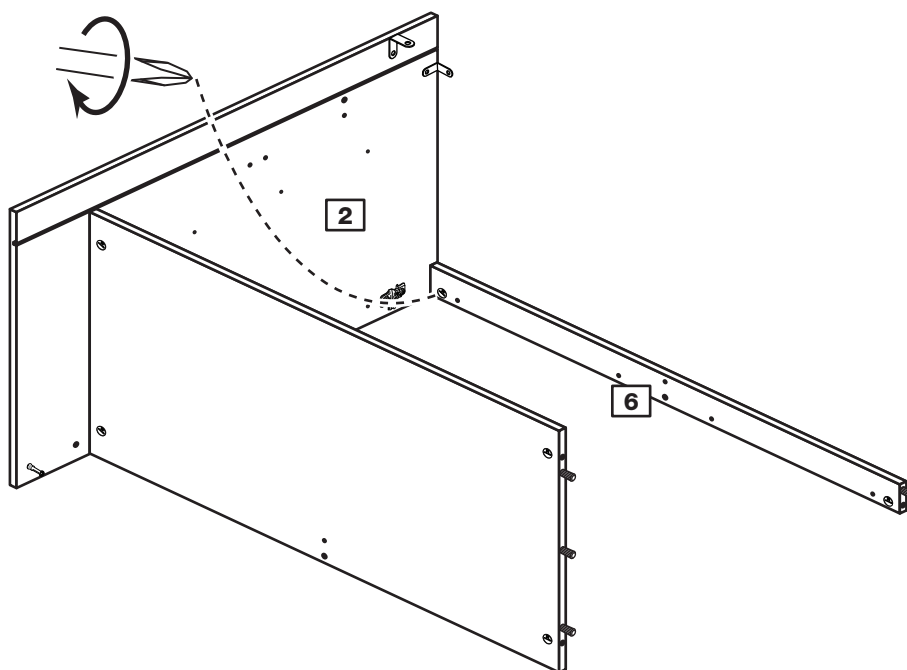

Assembly Instructions

Step 9

Fit the munting

Fit the munting **8** to the rail **6** and base **4** and secure using 2 screws **N**.

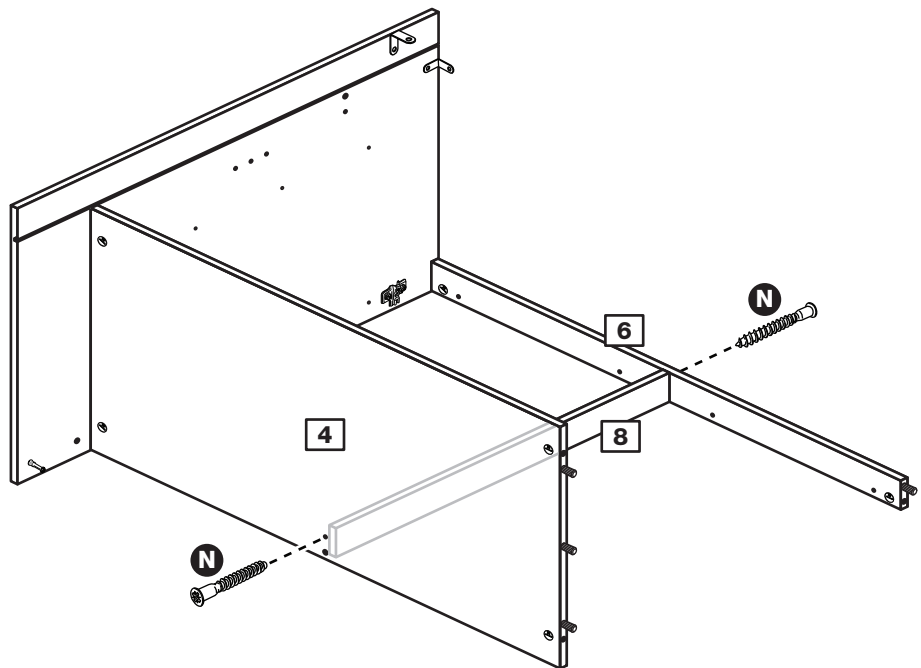

Step 10

Prepare the plinth

Insert 2 large locking nuts **C** and 2 wooden dowels **A** into the plinth **7**.

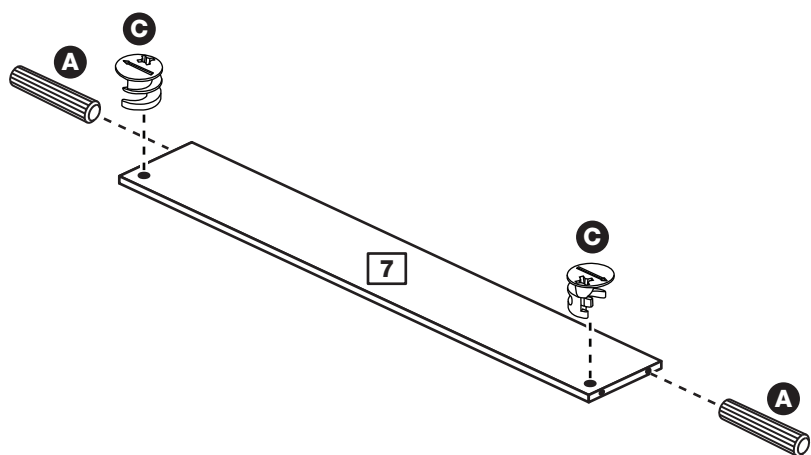

Assembly Instructions

Step 11

Fit the rail and plinth

Push the rail **6** and plinth **7** onto the right side **2** as shown.

Use a screwdriver to tighten the 2 large locking nuts **C** fitted to the 2 panels, as shown.

Note: Turn the large locking nuts **C** as far as they will go - more than 1/2 a turn.

Note: Support the rail **6** until the left side has been fitted in the next stage.

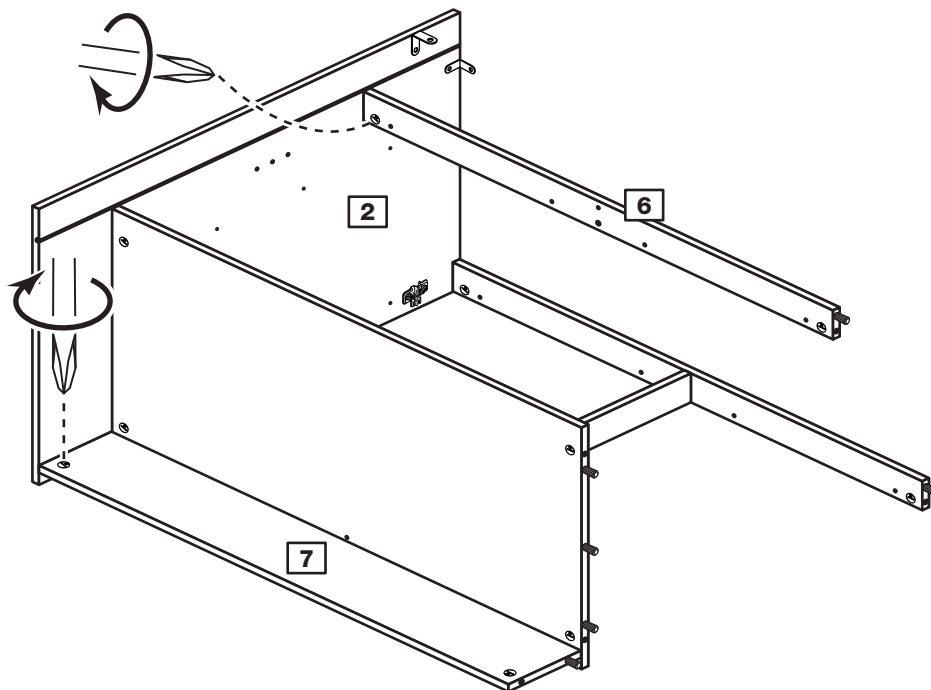

Step 12

Fit the left side

Push the left side **1** onto the assembly.

Use a screwdriver to tighten the 5 large locking nuts **C** fitted to the base **4**, rails **6** and plinth **7**.

Note: Turn the large locking nuts **C** as far as they will go - more than 1/2 a turn.

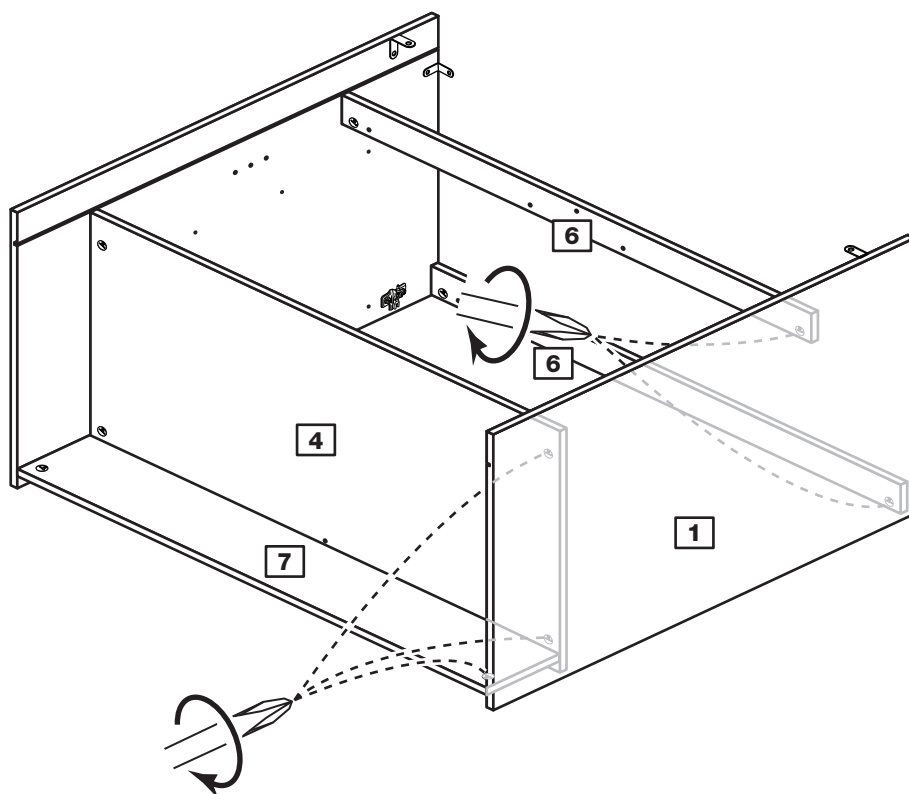

Assembly Instructions

Step 13

Fit the back

a: Square up the unit by making sure that measurement **x to x** equals **y to y**.

b: Slide the back **10** into the grooves along the left **1** and right **2** sides, as shown.

c: Secure the back **10** by tapping 7 nails **D** down into the back edge of the base **4** and 7 nails **D** into the back edge of the rail **6**.

Stand the unit up for the next stage.

a: The measurement from top corner X to bottom corner X must be equal to the measurement from top corner Y to bottom corner Y

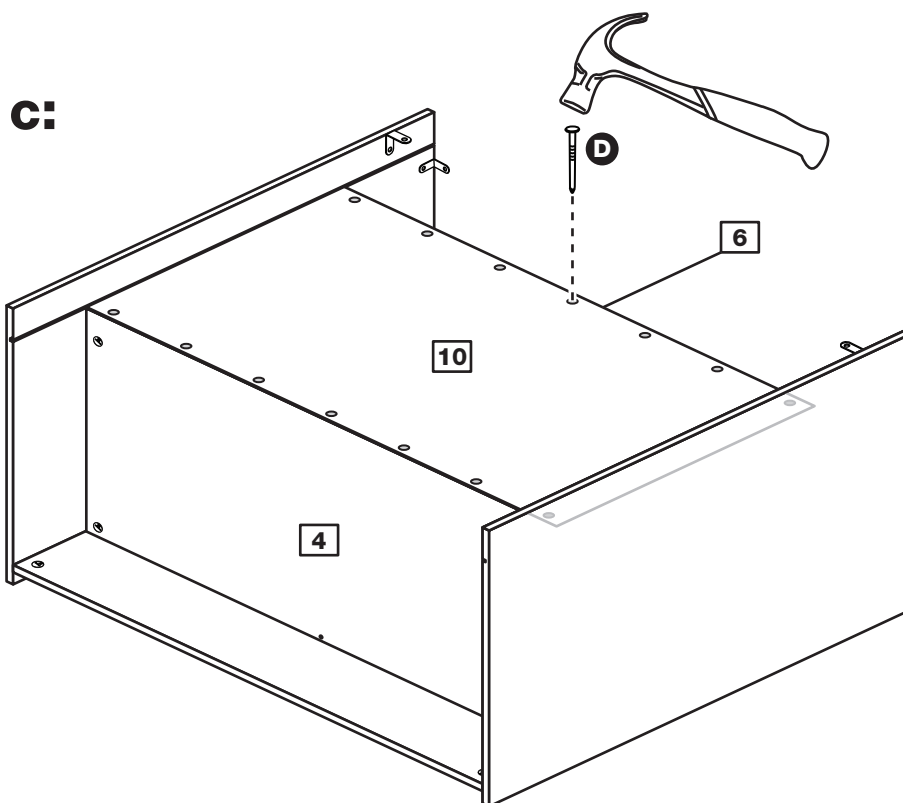
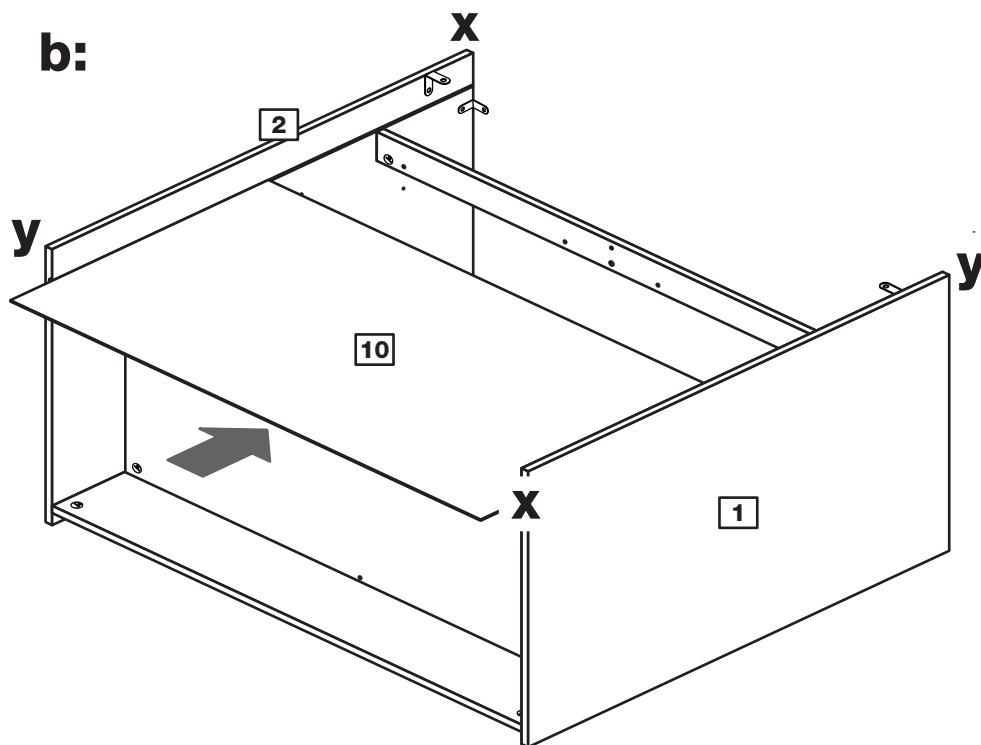

Assembly Instructions

Step 14

Fit the top

Position the top **3** onto the unit, making sure that the back edge is flush with the back edge of the sides **1** and **2**.

Secure the top **3** using screw **H** through the 2 brackets **F** fitted at the top edge of the side panels **1** and **2**.

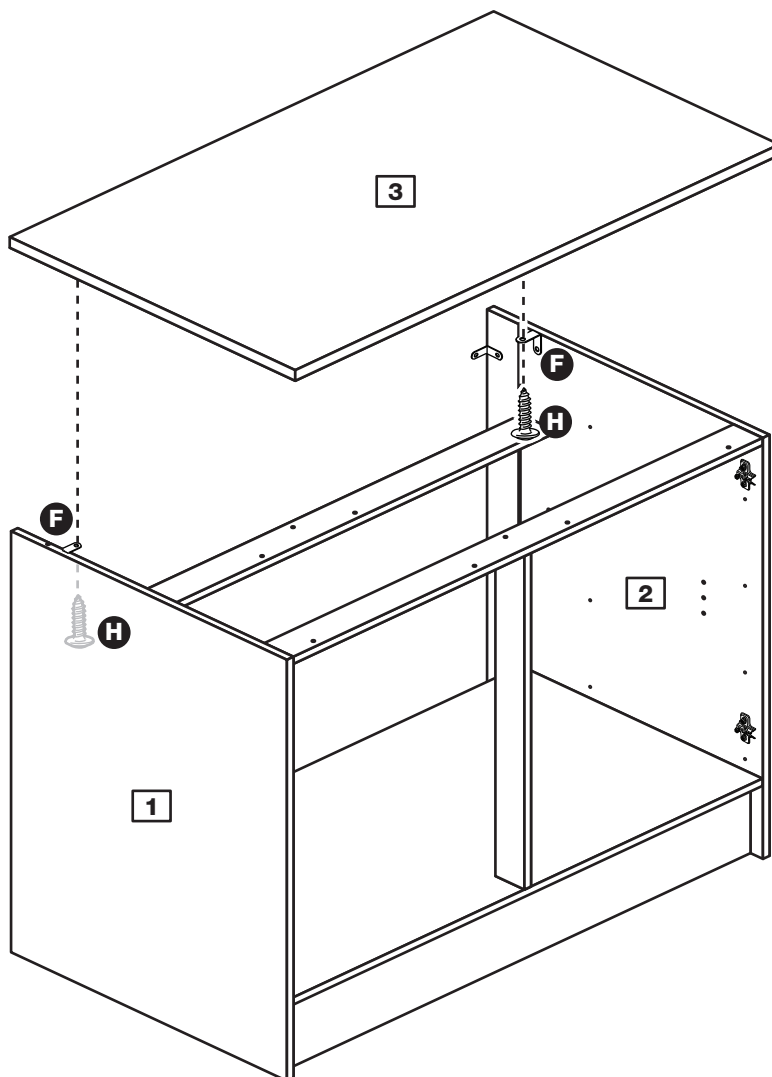

Step 15

Secure the front of the top

To secure the front of the top **3**, screw up through the 4 holes in the rail **6** at the front of the unit using screws **G**.

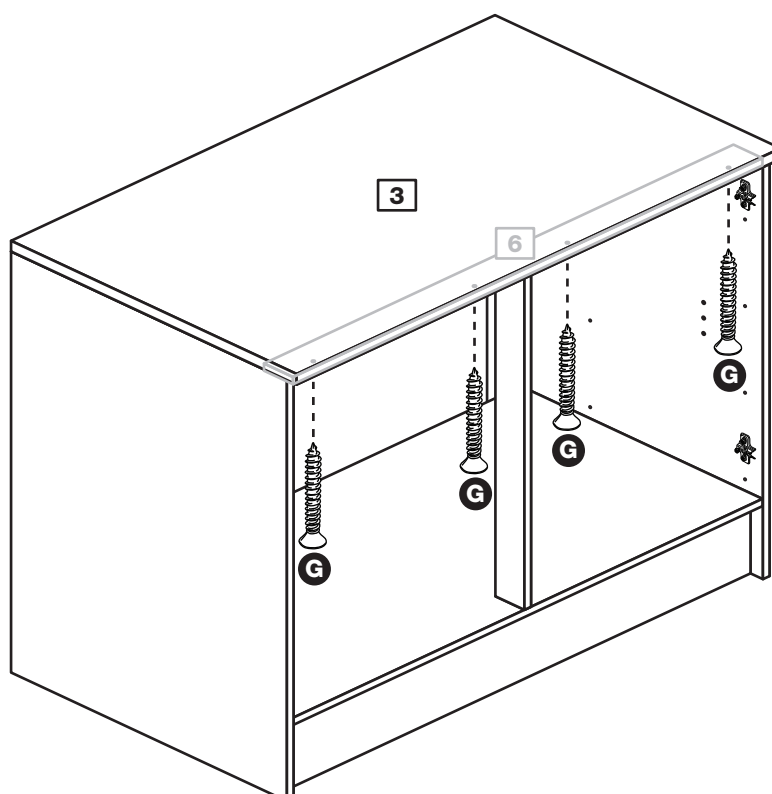

Assembly Instructions

Step 16

Secure the unit to the wall

Using the brackets **F** fitted to the back edge of the sides **1** and **2** screw the unit to the wall.

Fixings are not supplied as they will need to suit the wall type, and the length of screw will depend on the distance of the back of the Unit to the wall.



Warning: Take care when drilling the wall that you do not drill into any pipes, wires etc. If in doubt, consult an expert.

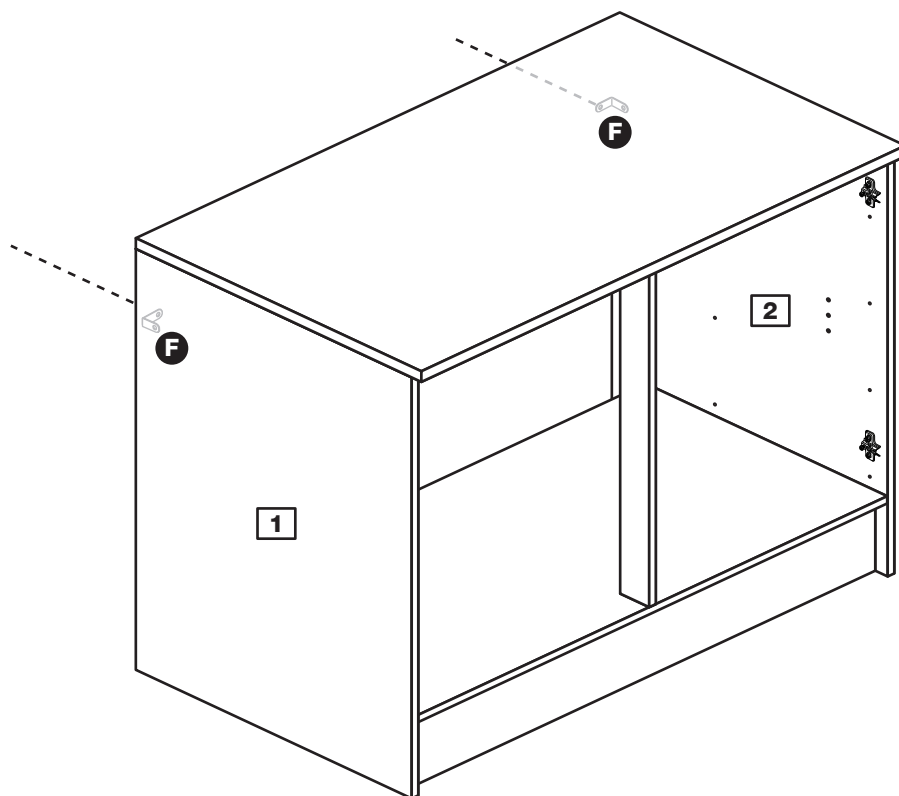

Step 17

Fit the shelf studs

Push 4 shelf studs **E** into the holes in the side panels **1** and **2** at the desired height.

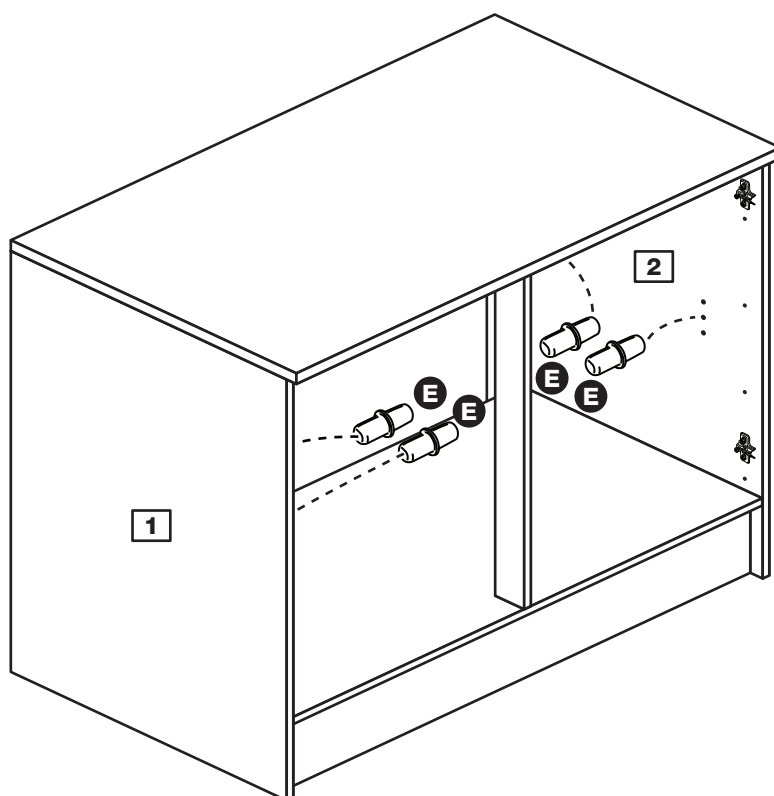

Assembly Instructions

Step 18

Fit the shelf

Manouvre the shelf **5** into the unit onto the shelf studs **E**.

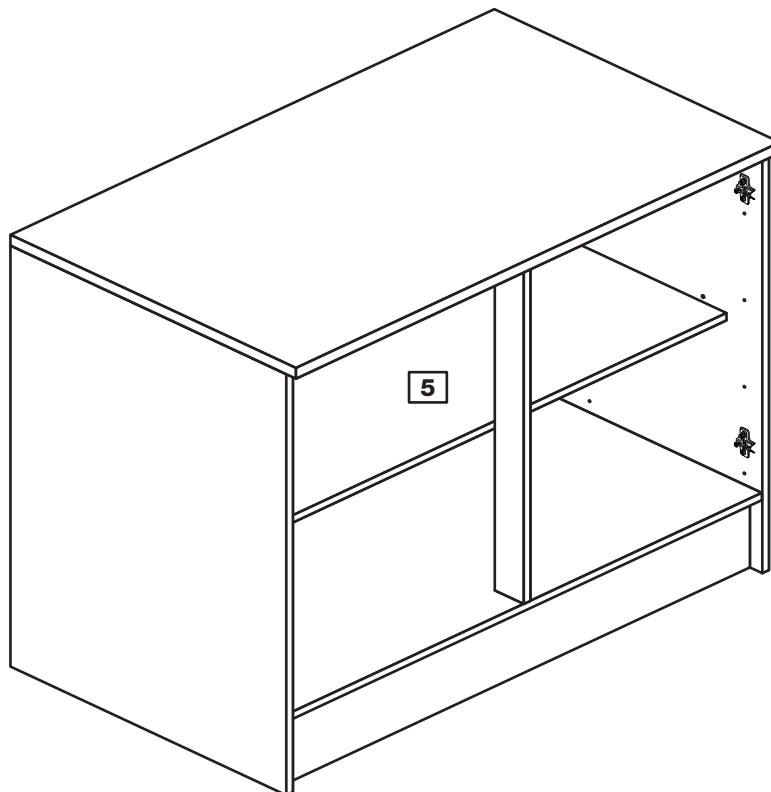

Step 19

Prepare the 2 doors

Push fit the 2 hinges **L** into the door **9**.

Secure each hinge with 2 screws **I**.

Note: Before securing with the screws, make sure that the hinges are positioned at 90 degrees with the front edge of the door.

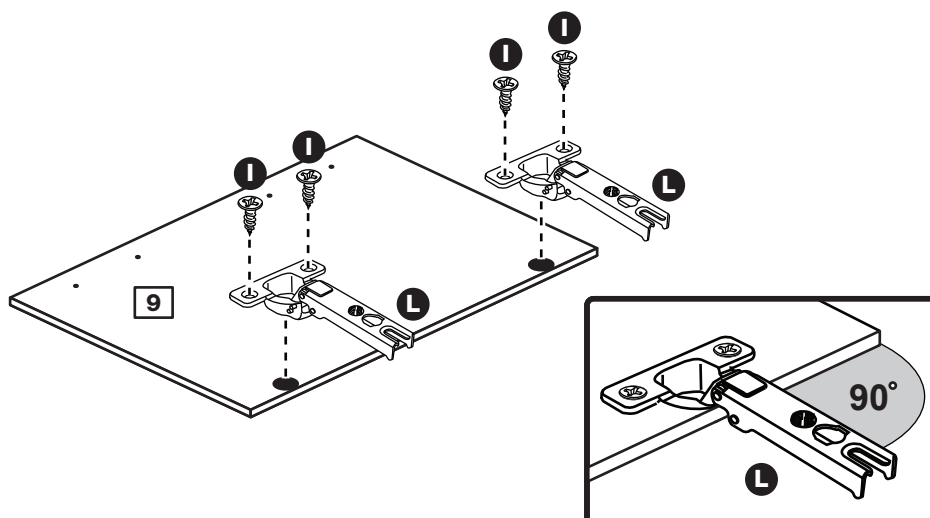

Assembly Instructions

Step 20

Drill the handle holes in the door

Important: Please follow these instructions carefully.

Lay the doors **9** down onto a smooth surface.

Important: Check that the holes and hinges are in the same place as the diagrams.

Note: We recommend the use of a small piece of waste wood, placed behind the hole while drilling, to reduce the possibility of any breakout.

Using the pilot hole in the rear face of the door **9**, drill through the holes indicated opposite, using a 2.5mm diameter drill.

Turn the door **9** over and open out the 2.5mm holes that you have just drilled by drilling back through them with a 5mm drill.

IMPORTANT Carefully choose which 2 holes you need to drill in each of the doors

This will be the left door

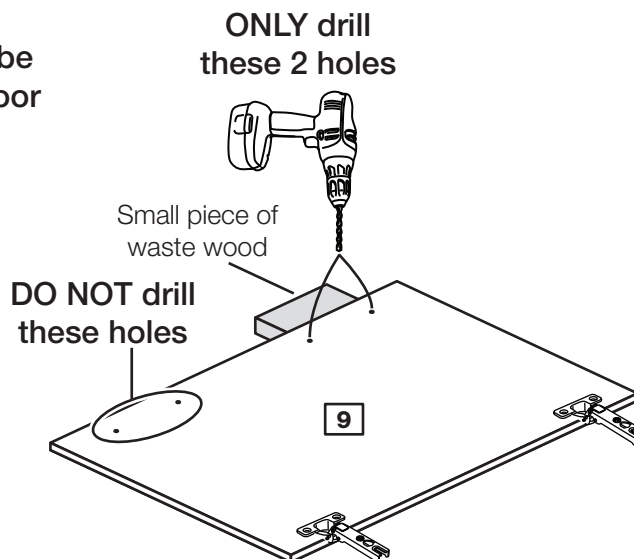

This will be the right door

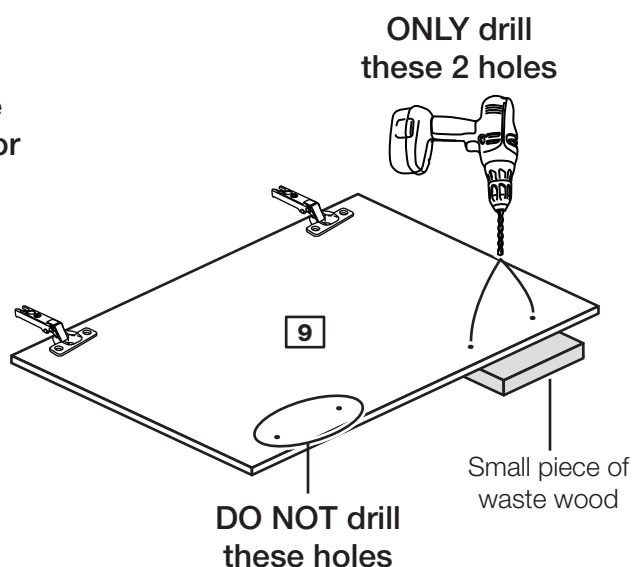

Assembly Instructions

Step 21

Fit doors and handles

2 people are needed here

Note: The easiest way to attach the door **9** is to fit the top hinge first, then align and fit the other hinges.

a: Push the hinge **L** onto the front part of the hinge plate **K**.

b: Keep the hinge **L** FLAT against the hinge plate **K** as you slide it across as far as it will go. Tighten screw A.

c: The hinge **L** must be flat against the hinge plate **K** prior to any adjustment.

d: The hinge **L** must NOT be AT AN ANGLE to the hinge plate **K** when assembled. This would indicate that the recess at the bottom of screw B had not located in the slot in the hinge plate and the hinge would not be secure. Remove the hinge from the hinge plate and then re-assemble being careful to follow instructions a-c.

e: Attach a handle **M a** to the door **9** using 2 screws **M b**.

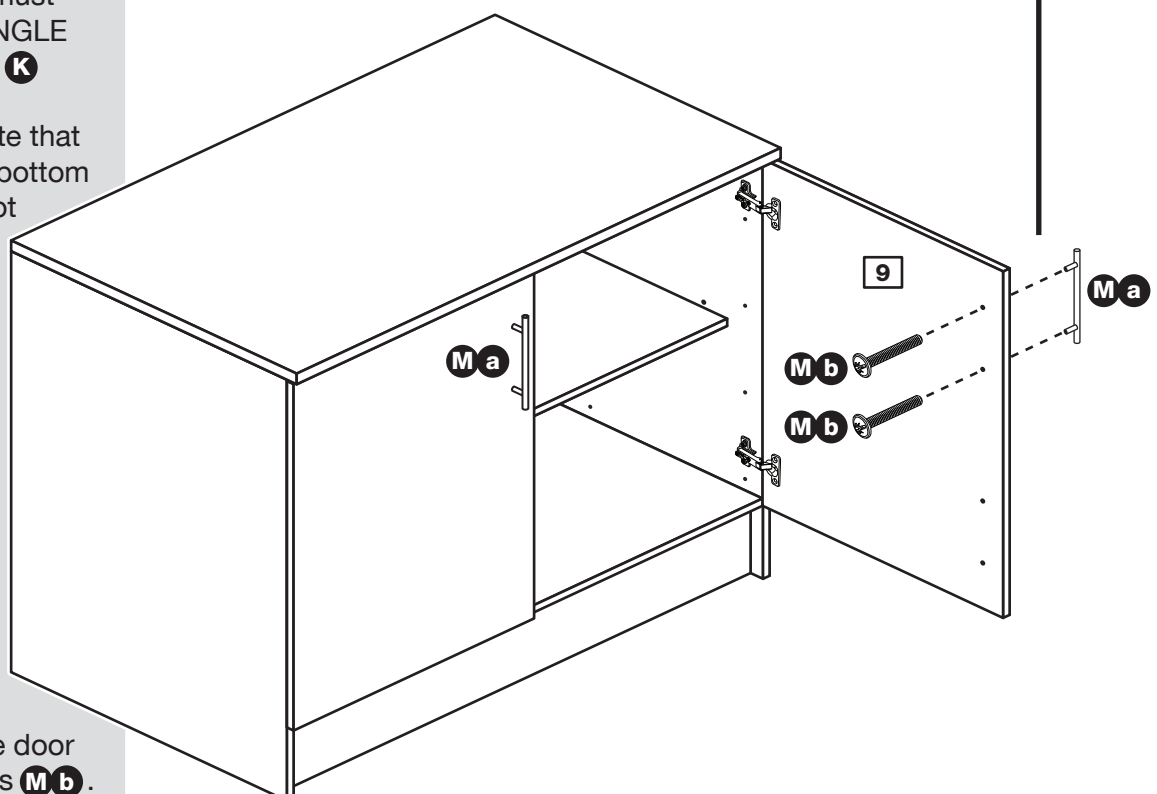
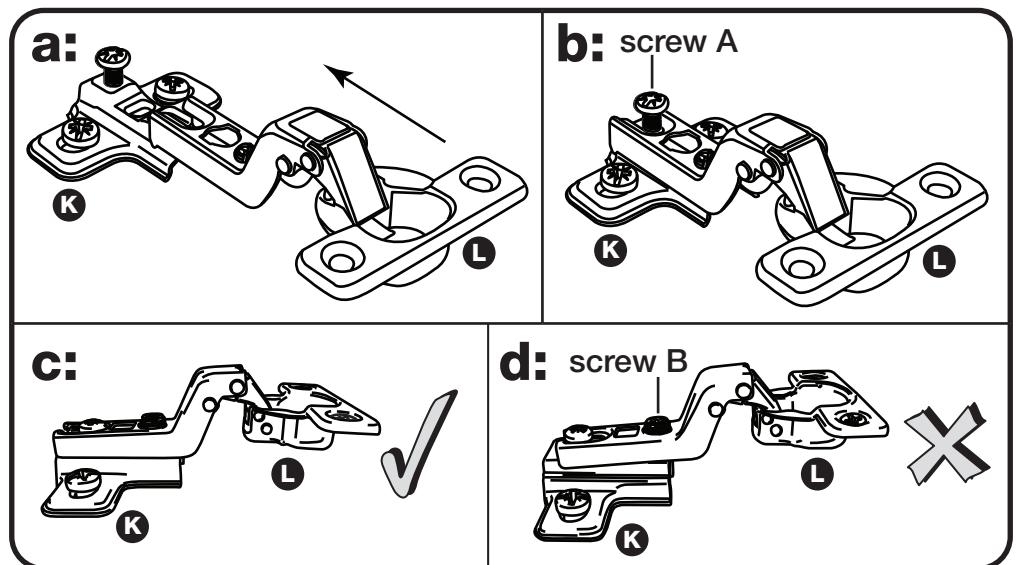

Assembly Instructions

Step 22

Adjust the doors if needed

a: Height adjustment.

Loosen screws A on hinge plates and move door up or down as required.
Retighten screw A.

b: Forward and Back adjustment.

Loosen screw B on hinge plate and move door in or out as required.
Retighten screw B.

c: Sideways adjustment.

To move door 'out' loosen screw C.
To move door 'in' tighten screw C

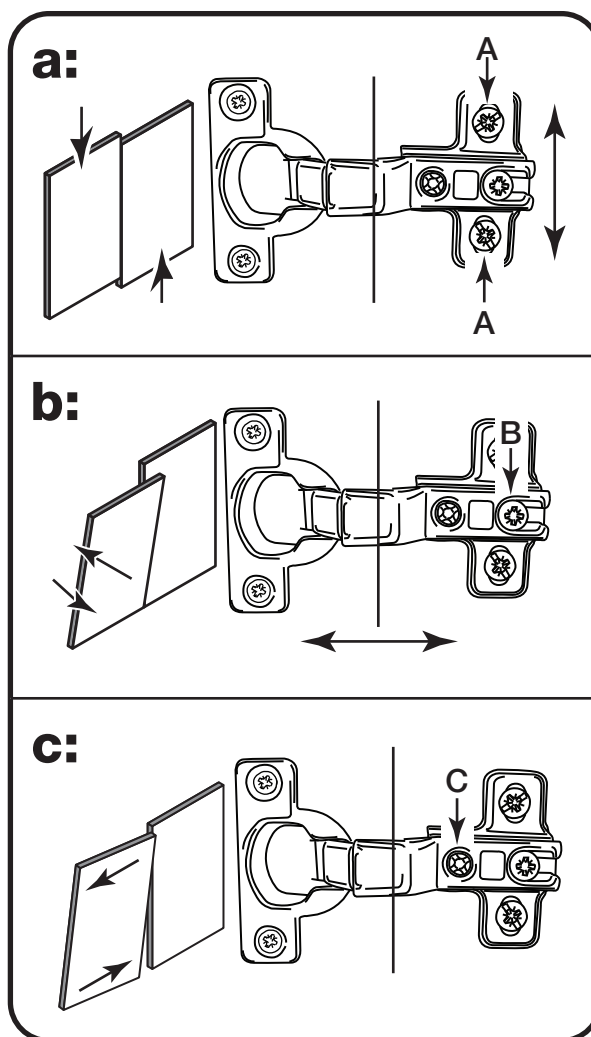

Step 23

Fit the door buffers to both doors

Stick a door buffer **J** onto each corner of the door **9** so that they hit the edge of the side panel when the door is closed.

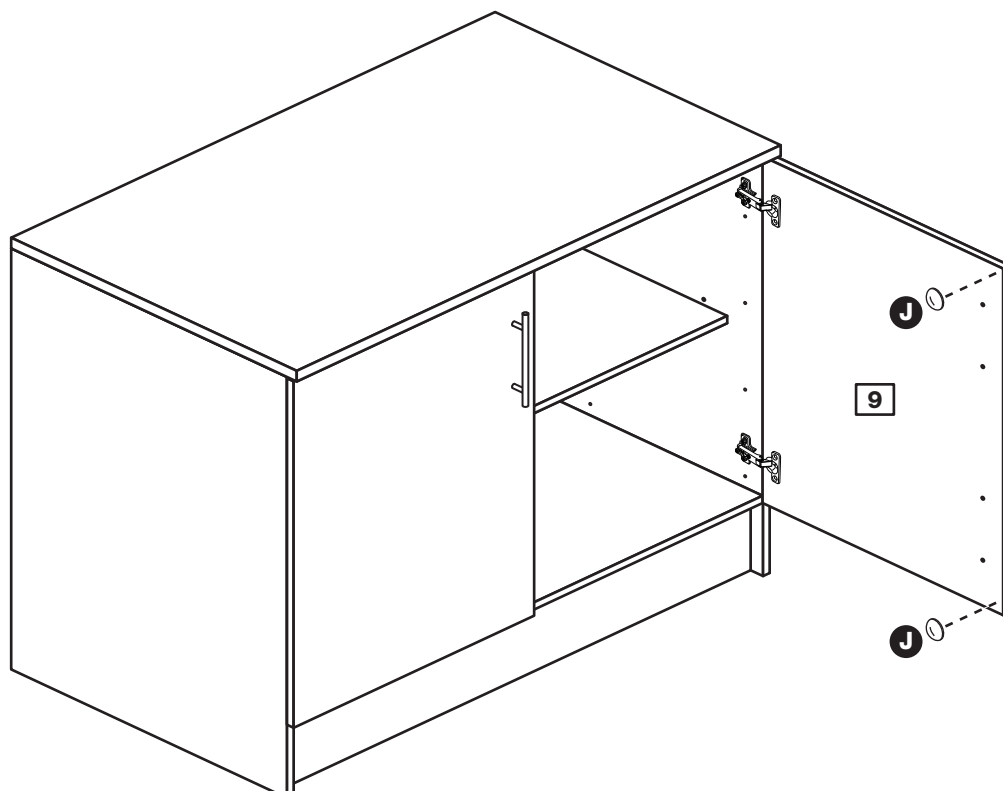

Assembly Instructions

Step 24

Assembly is complete



Warning: The unit is heavy. Lift with care.

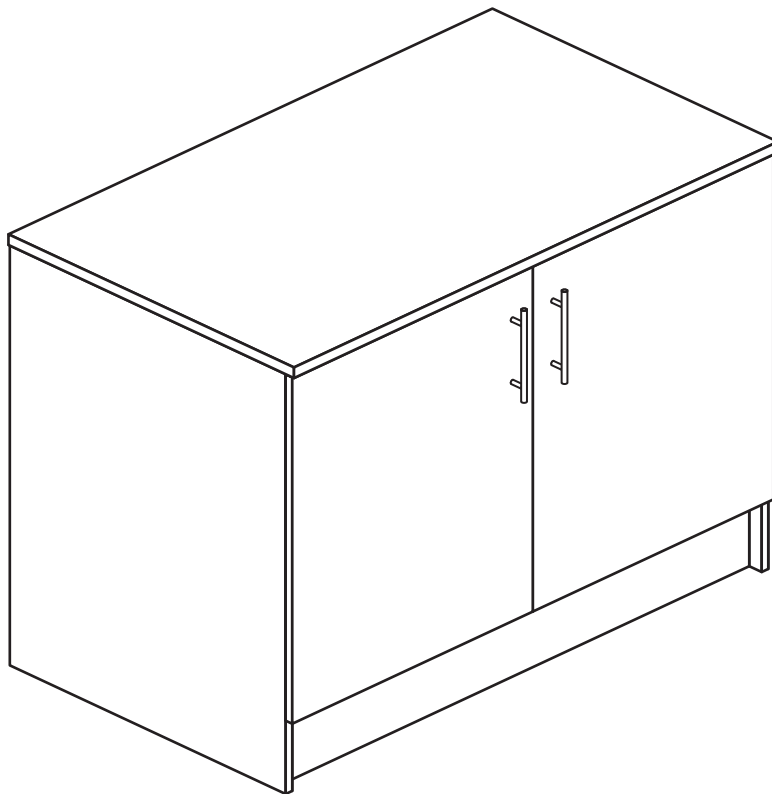

If you need help or have damaged or missing parts, call the **Customer Helpline: 08456 400800** and quote the reference numbers on the component pages.

Argos Ltd, 489-499 Avebury Boulevard, Central Milton Keynes, MK9 2NW

