

EN ASSEMBLY INSTRUCTIONS ES CONSIGNES DE MONTAGE FR INSTRUCCIONES DE MONTAJE IT MONTAGEANLEITUNG
DE MONTAGE-VOORSCHRIFTEN NL ISTRUZIONI D'ASSEMBLAGGIO PT INSTRUÇÕES DE MONTAGEM PL INSTRUKCJA
MONTAŻU HU ÖSSZESZERELÉSI ÚTMUTATÓ RO INSTRUCȚIE DE MONTAJ CZ POKYNY K MONTÁŽI SK POKYNY NA MONTÁŽ
HR UPUTE ZA POSTAVLJANJE LT MONTAVIMO INSTRUKCIJA LV MONTĀŽAS INSTRUKCIJA AL UDHËZUES MONTIMI
BG ИНСТРУКЦИЯ ЗА МОНТАЖ RU ИНСТРУКЦИЯ ПО МОНТАЖУ UA ІНСТРУКЦІЯ З МОНТАЖУ SLD NAVODILO ZA MONTAŽO
SRB UPUTSTVA ZA MONTAŽU

Bahamas Balcony

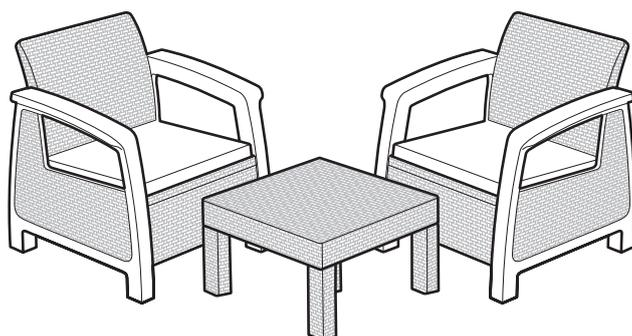

Bahamas Lounge

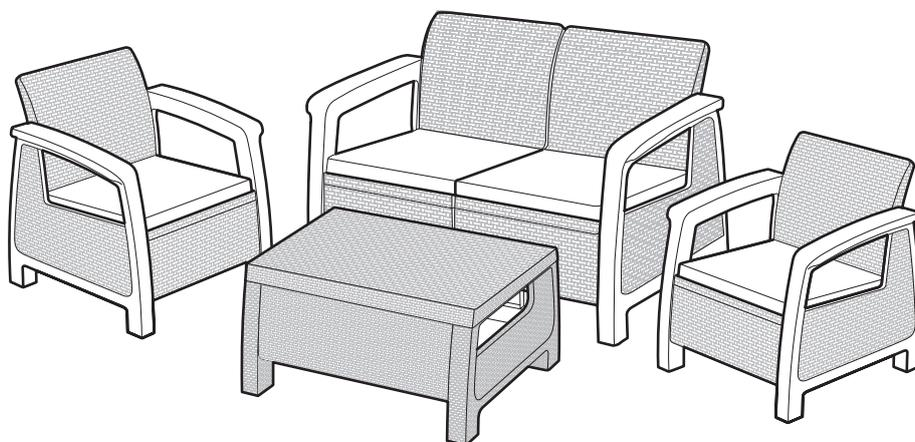

Bahamas Storage

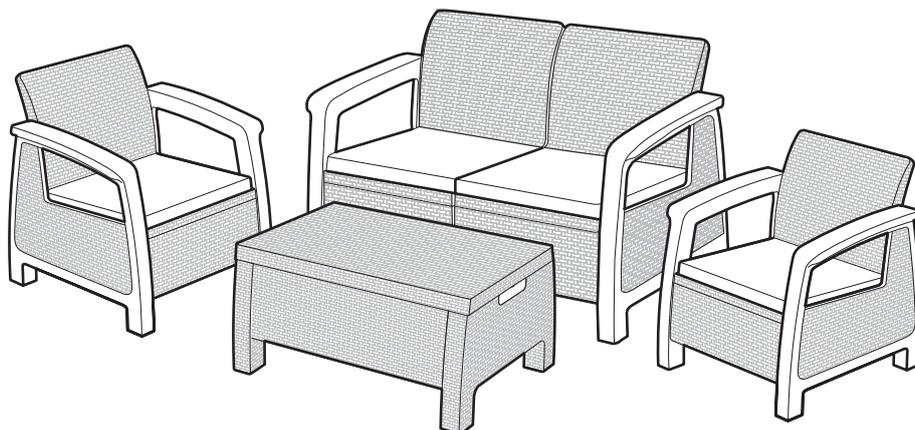

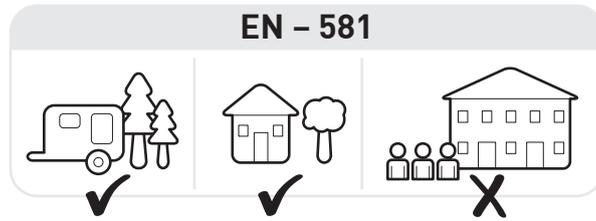
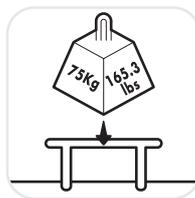
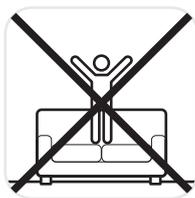
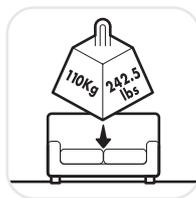

- EN** IF THERE ARE MISSING OR BROKEN PARTS, PLEASE DO NOT RETURN THE PRODUCT TO THE STORE.
Please log onto our website, or contact Customer Service at:
- FR** S'IL Y A DES PIÈCES MANQUANTES OU CASSÉES, NE RETOURNEZ PAS LE PRODUIT AU MAGASIN.
Veuillez visiter notre site Internet, ou contacter notre Service Clientèle:
- ES** SI HUBIERA ALGUNA PARTE FALTANTE O DAÑADA, NO DEVUELVA EL PRODUCTO A LA TIENDA.
Inicie sesión en nuestro sitio en Internet o contáctese con nuestro servicio de atención al cliente:
- DE** BITTE BRINGEN SIE IHR PRODUKT NICHT GLEICH ZUM LADEN ZURÜCK, FALLS TEILE FEHLEN ODER DEFEKT SIND.
Bitte loggen Sie in unsere Website ein oder wenden Sie sich an unseren Kundenservice:
- NL** IN GEVAL VAN ONTBREKENDE OF GEBROKEN ONDERDELEN HET PRODUCT NIET NAAR DE WINKEL RETOURNEREN.
Ga naar onze website of neem contact op met Klantenservice:
- IT** IN CASO DI PARTI MANCANTI O DANNEGGIATE, EVITARE DI RESTITUIRE IL PRODOTTO AL NEGOZIO.
Accedere al nostro sito web o contattare il Servizio Clienti:
- PT** SE HOVER PEÇAS EM FALTA OU PARTIDAS, NÃO DEVOLVA O PRODUTO À LOJA.
Entre na nossa página de Internet ou contacte o Serviço de Clientes:
- PL** W PRZYPADKU BRAKUJĄCYCH BĄDŹ ZŁAMANYCH CZĘŚCI PROSIMY NIE ZWRACAĆ PRODUKTU DO SKLEPU.
W takim przypadku prosimy zalogować się na naszej stronie internetowej lub skontaktować się z Działem Obsługi Klienta:
- HU** HIÁNYZÓ VAGY TÖRÖTT ELEMÉK ESETÉN KÉRJÜK NE KÜLDJE VISSZA A TERMÉKET AZ ÜZLETBE
Ebben az esetben jelentkezzen be az internetes oldalunkon vagy lépjen kapcsolatba az Ügyfélszolgálati Osztállyal:
- RO** DACĂ SÎNT PIESE CARE LIPSESC SAU CARE SÎNT RUPTE VĂ ROG SĂ NU RETURNAȚI PRODUSUL LA MAGAZINUL
În acest caz vă rog să vă logați pe pagina Internet sau să contactați Serviciul Clienti:
- CZ** V PŘÍPADĚ CHYBĚJÍCÍCH NEBO POŠKOZENÝCH SOUČÁSTÍ PROSÍME NEVRACEJTE PRODUKT DO OBCHODU
V takovém případě se přihlaste na naši internetovou stránku nebo kontaktujte oddělení péče o zákazníka:
- SK** V PRÍPADE CHÝBAJÚCICH ALEBO POŠKODENÝCH SÚČASŤÍ PROSÍME NEVRACAJTE PRODUKT DO OBCHODU
V takom prípade sa prihláste na našu internetovú stránku alebo kontaktujte oddelenie starostlivosti o zákazníka:
- HR** U SLUČAJU NEDOSTATKA ILI SLOMLJENIH DIJELOVA, MOLIMO NEMOJTE VRATITI PROIZVOD U TRGOVINU.
U tom slučaju, prijavite se na našoj web stranici ili kontaktirajte službu za korisnike:
- LT** DALIŲ TRŪKUMO AR SULŪŽIMO ATVEJU PRAŠOME PRODUKTO NEGRAŽINTI Į PARDUOTUVĘ.
Tokiu atveju prašome prisijungti mūsų internetinėje svetainėje arba susisiekti su Kliento aptarnavimo skyriumi:
- LV** DETAĻU TRŪKUMA VAI SABOJĀTU DETAĻU GADĪJUMĀ LŪDZAM PRODUKTU NEATDOT VEIKALĀ.
Tādā gadījumā lūdzam ieloties mūsu interneta lapā vai kontaktēties ar Klienta Apkalpošanas Daļu:
- BG** НЪСЕ ЈУ МУНГОЈНЪ ДИСА ПЈЕСЕ ОСЕ КЕНИ ПЈЕСЕ ТЪ ТЫЕРА ЈУ ЛУТЕМИ ТА МОС КТХЕНИ ПРОДУКТИН НЪ ДУҚАНИН.
Нѐ кѐтѐ раст ју лутеми тѐ идентификohenи нѐ uebfaen tonѐ тѐ интернетит ose тѐ контактони Degѐn e Shѐrbimit тѐ Klientit:
- RU** В СЛУЧАЙ, ЧЕ ИМА ЛИПСВАЩИ ИЛИ СЧУПЕНИ ЧАСТИ, ВИ МОЛИМ ДА НЕ ВРЪЩАТЕ ПРОДУКТА В МАГАЗИНА.
Влезте на нашия сайт или се свържете с отдел "Обслужване на клиенти":
- UA** В СЛУЧАЕ ОТСУТСТВИЯ ИЛИ БРАКОВАННЫХ ЧАСТЕЙ ПРОСЬБА НЕ ВОЗВРАЩАТЬ ПРОДУКТ В МАГАЗИН.
В данном случае просьба зарегистрироваться на нашем веб-сайте или связаться с Отделом Обслуживания Клиентов:
- AL** У ВИПАДКУ ВІДСУТНОСТІ АБО ПОШКОДЖЕННЯ ЧАСТИН ПРОХАННЯ НЕ ПОВЕРТАТИ ПРОДУКТ В МАГАЗИН.
В даному випадку прохання зареєструватися на нашому веб-сайті або зв'язатися з Відділом Обслуговування Клієнтів:
- SLO** V PRIMERU, ČE NI VSEH DELOV OZIROMA SO DELI POLOMLJENI, PROSIMO, DA NE VRAČATE IZDELKA V TRGOVINU.
V takšnem primeru prosimo, da se prijavite na naši spletni strani oziroma se obrnete na Oddelek za storitve za stranke:
- SRB** U SLUČAJU AKO NE DOSTAJU DELOVI ILI AKO SU POLOMLJENI, MOLIMO VAS NEMOJTE DA VRATITE PROIZVOD U PRODAVNICU.
U tom slučaju, molimo vas da se prijavite na našem sajtu ili kontaktirajte Korisnički servis:

WWW.KETER.COM

US: # 1-888-374-4262
Canada: # 1-800-661-6721
UK: # 0121-5060008

France: # 33-1-49-46-71-00
Italy: # 39-02-4451241
Benelux & Germany: # 31-(0)-884722277

Spain: # 34-976-460-267
Scandinavia: # 45-72-44-06-05
East Europe Hungary: # 36-52-565-900 / www.curver-lifestyle.com
East Europe Poland: # 48-59-841-12-30 / www.curver-lifestyle.pl

Keter Plastic Ltd.
2 Sapir St., Industrial Area, Herzliya 46852, Israel Tel: +972-9-9591212 Fax: +972-9-9554993

ASSEMBLY PARTS | PIÈCES À ASSEMBLER | MONTAGETEILE | PIEZAS DE ENSAMBLE | ONDERDELEN | PARTI DA MONTARE | PEÇAS DE MONTAGEM | CZĘŚCI MONTAŻOWE | ALKATRÉSZEK | PIESE DE MONTAJ | MONTÁŽNÍ SOUČÁSTI | MONTÁŽNE SÚČASTI | MONTAŽNI DIJELOVI | MONTAVIMO DALYS | MONTĀŽAS DETALAS | PĒSĒT PĒR MONTĪM | МОНТАЖНИ ЕЛЕМЕНТИ | ФУРНИТУРА | ФУРНИТУРА | MONTAŽNI DELI | MONTAŽNI DELOVI

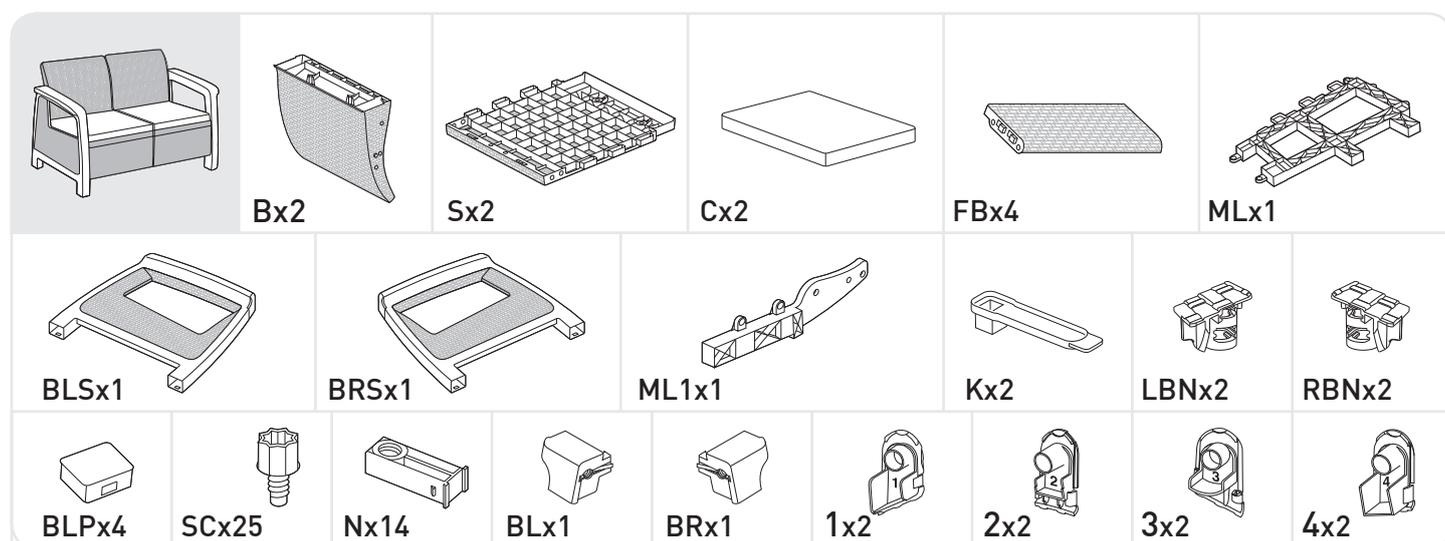
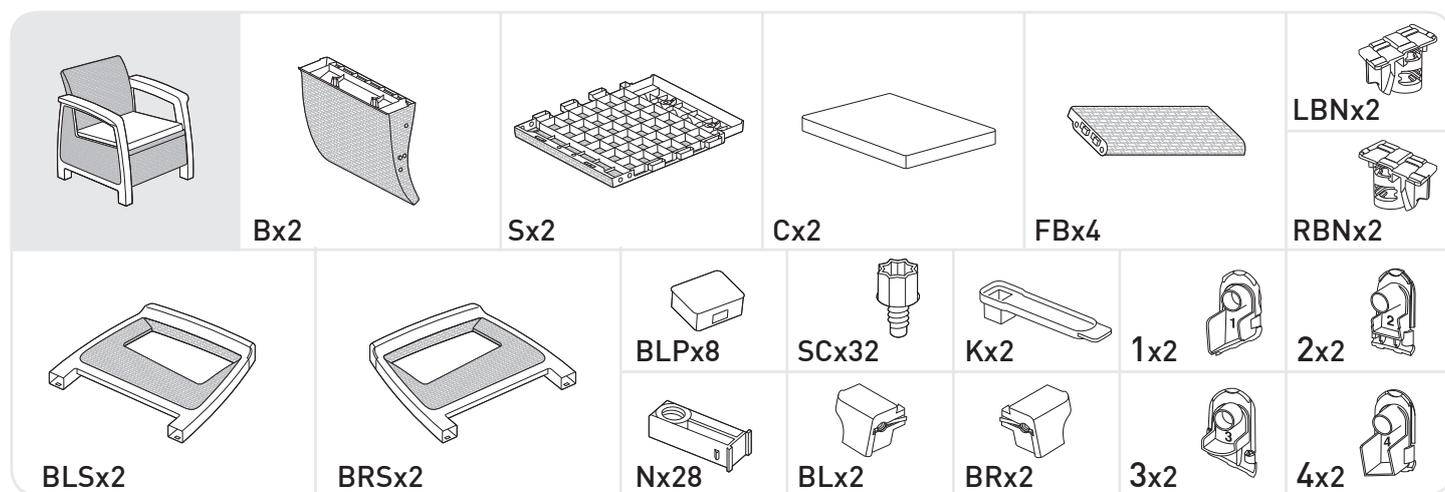
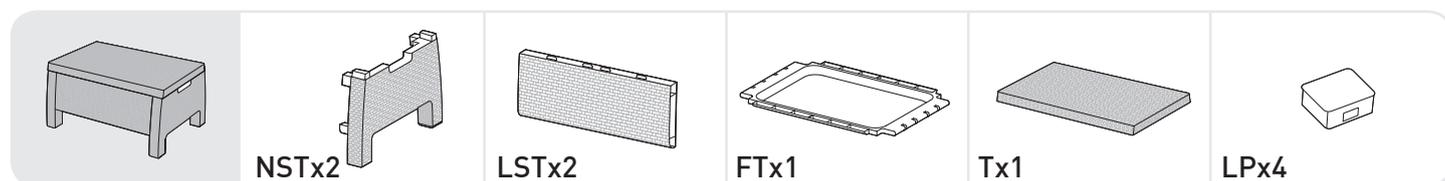
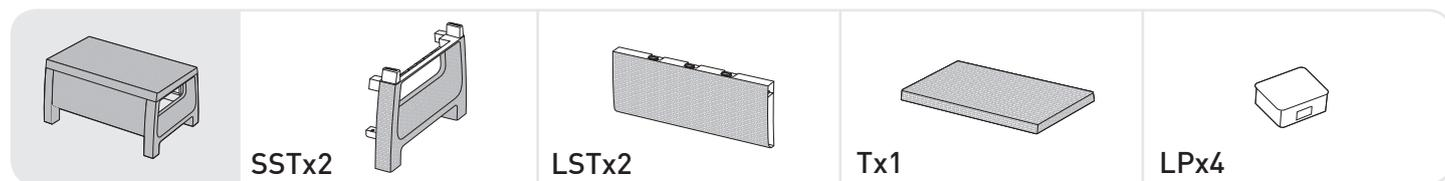
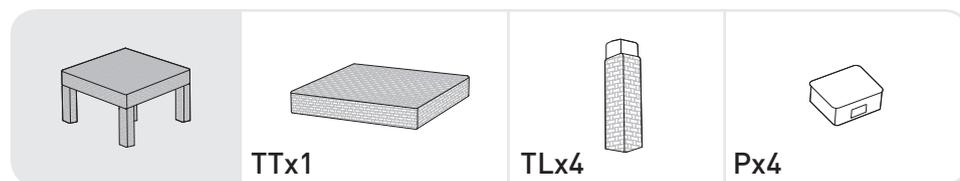

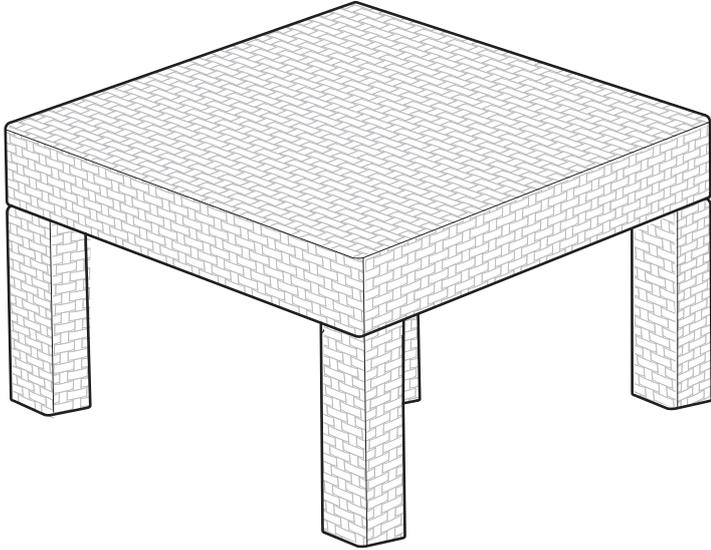

1 |  TTx1 |  TLx4 |  Px4

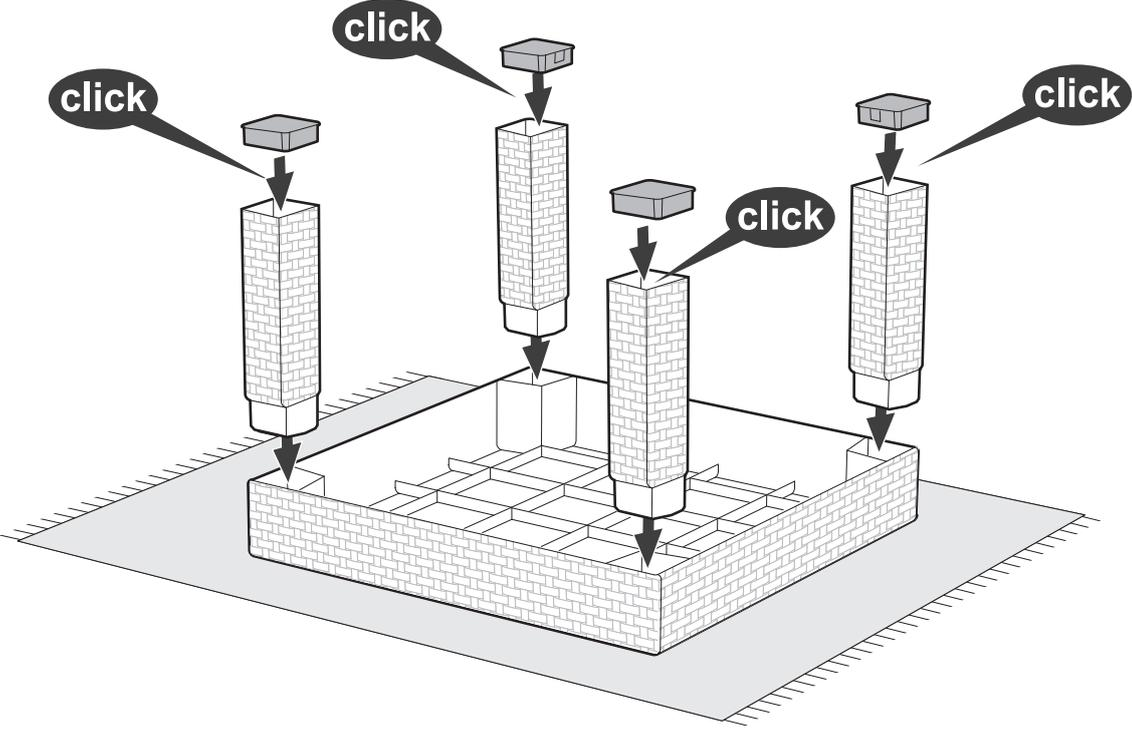

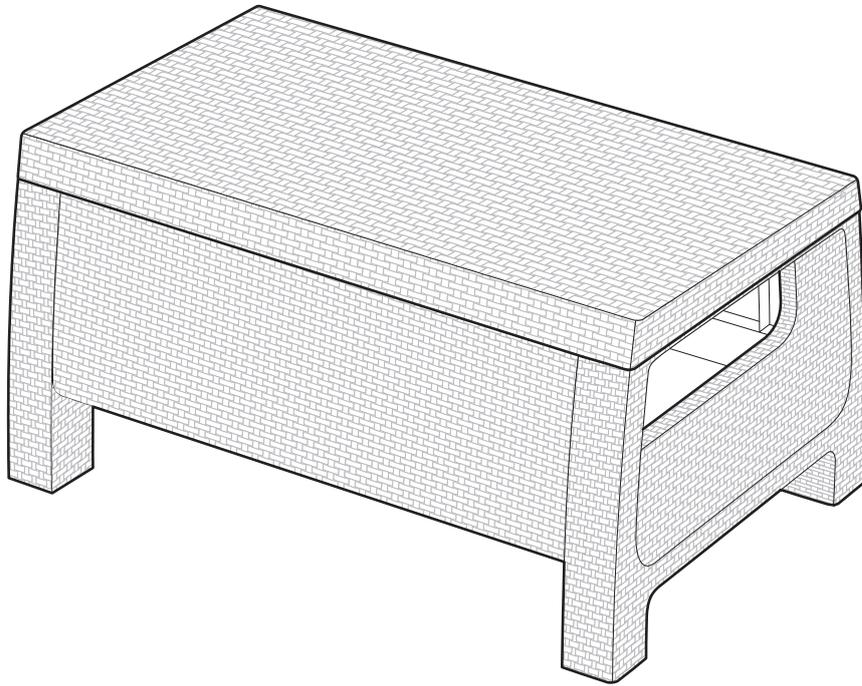
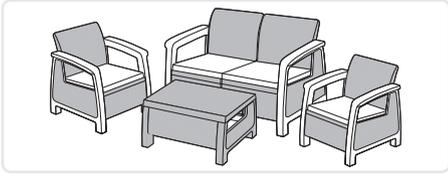

1



LSTx2



SSTx2

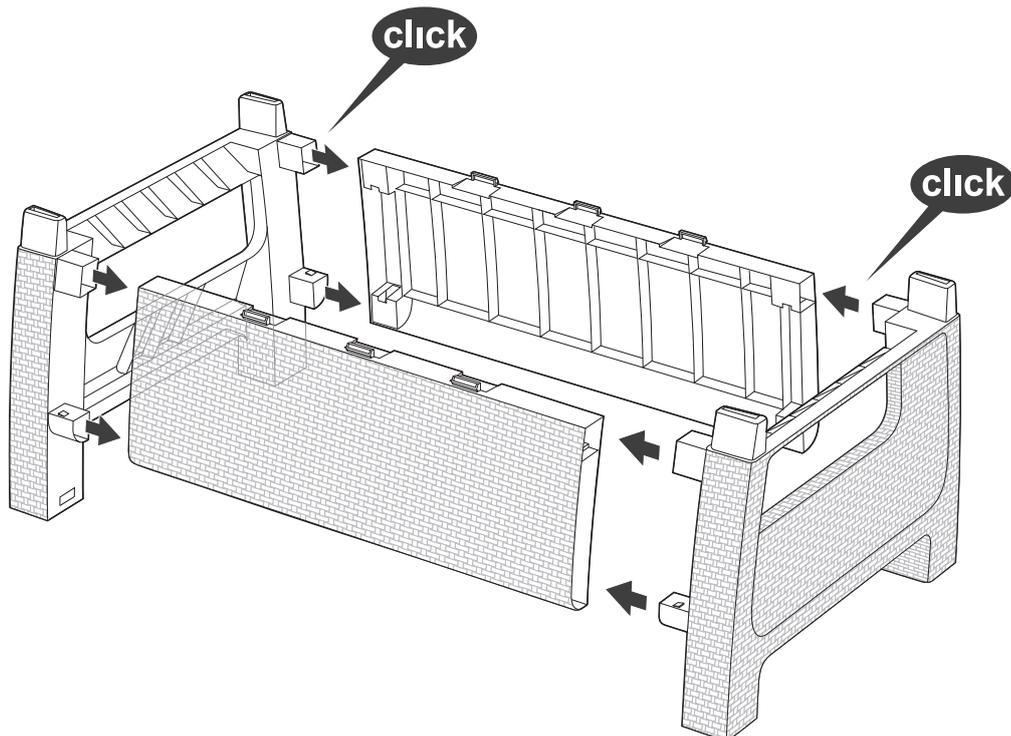

2



LPx4

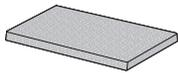

Tx1

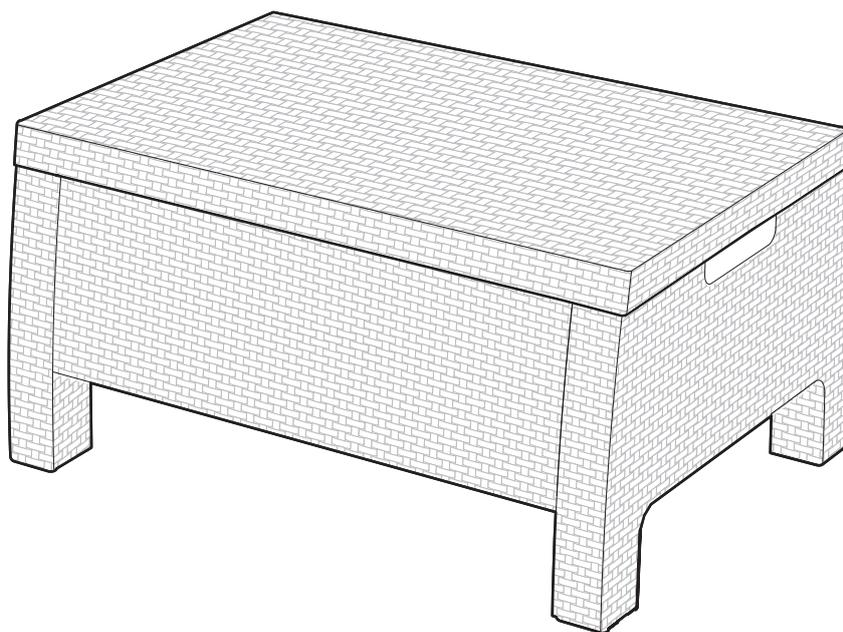
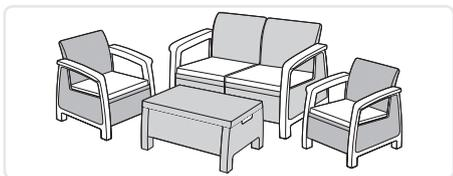
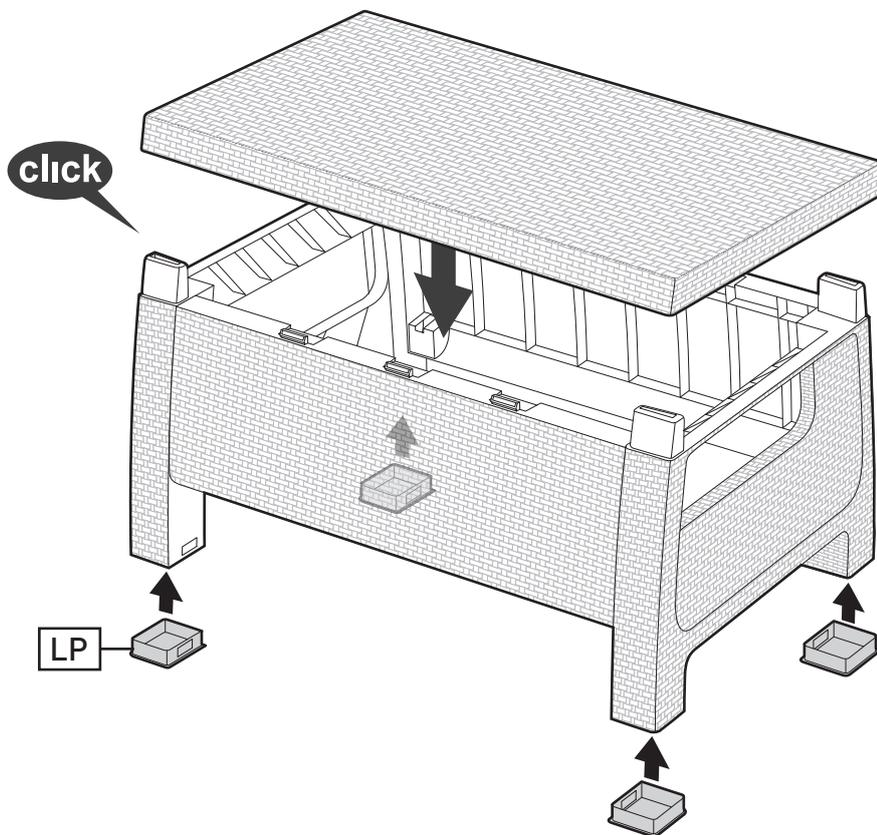

1

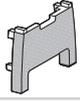

NSTx1



LPx2

X2

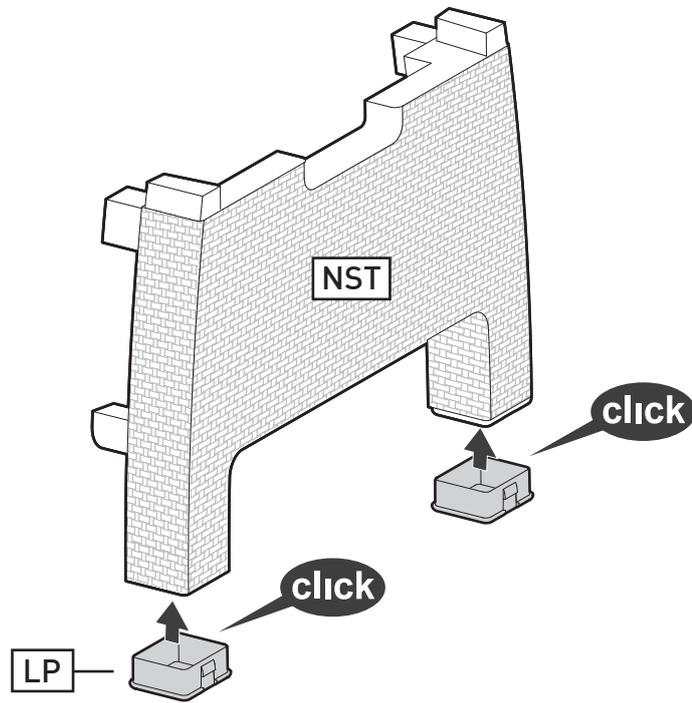

2



LSTx2

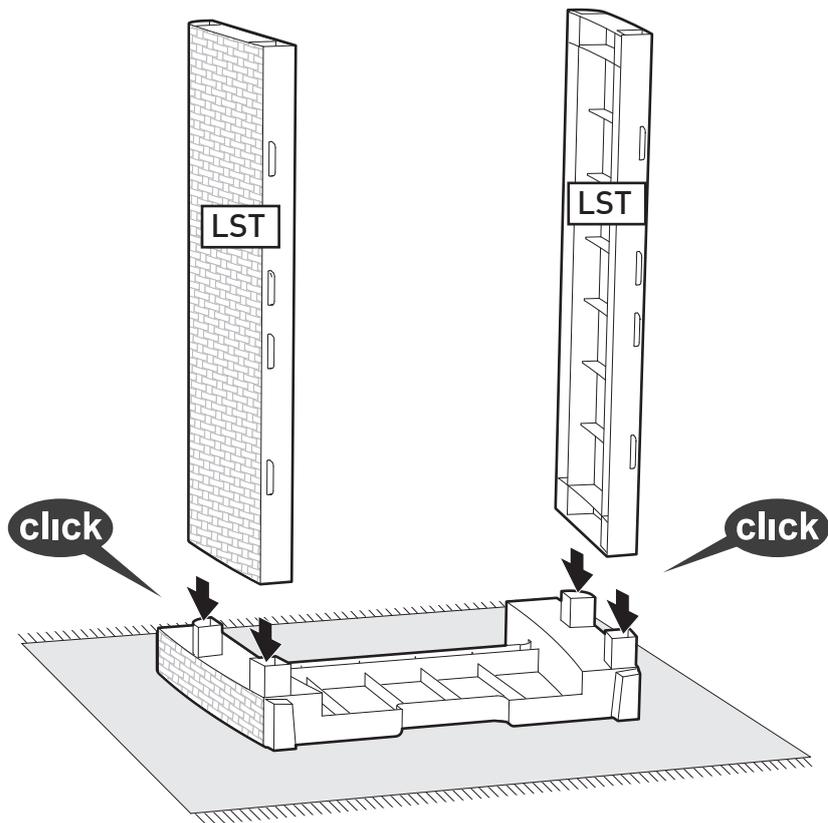

3



FTx1

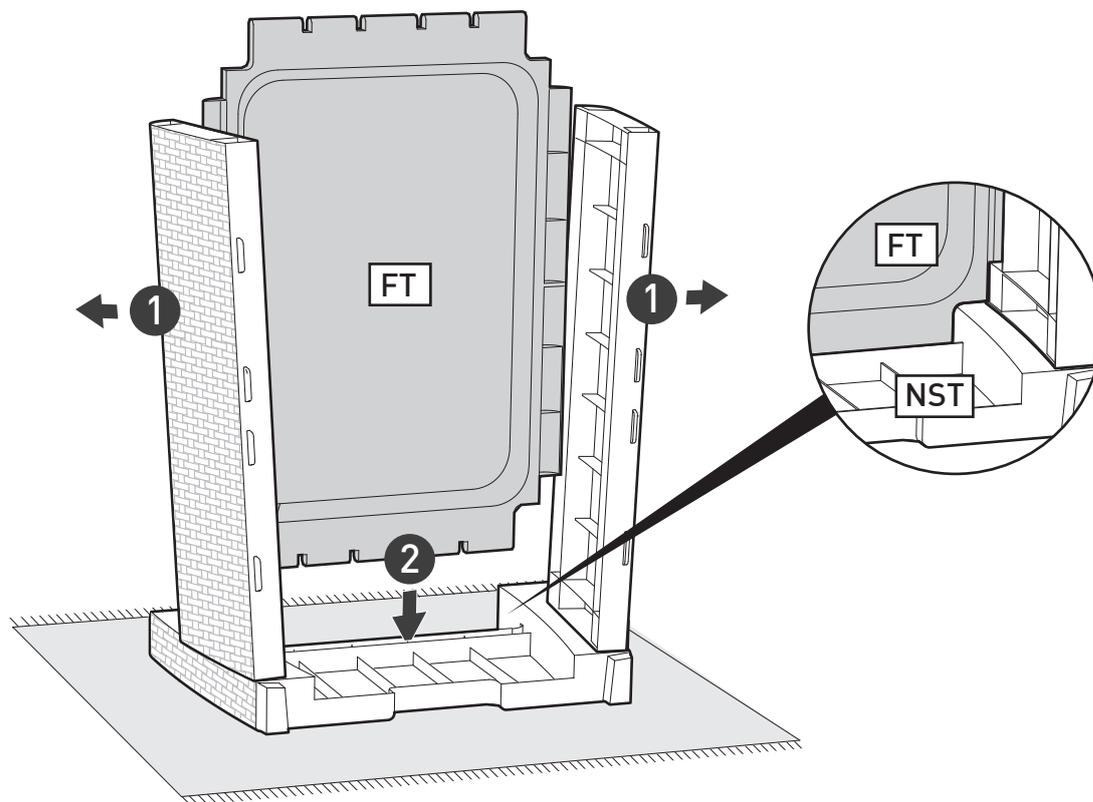

4



NSTx1

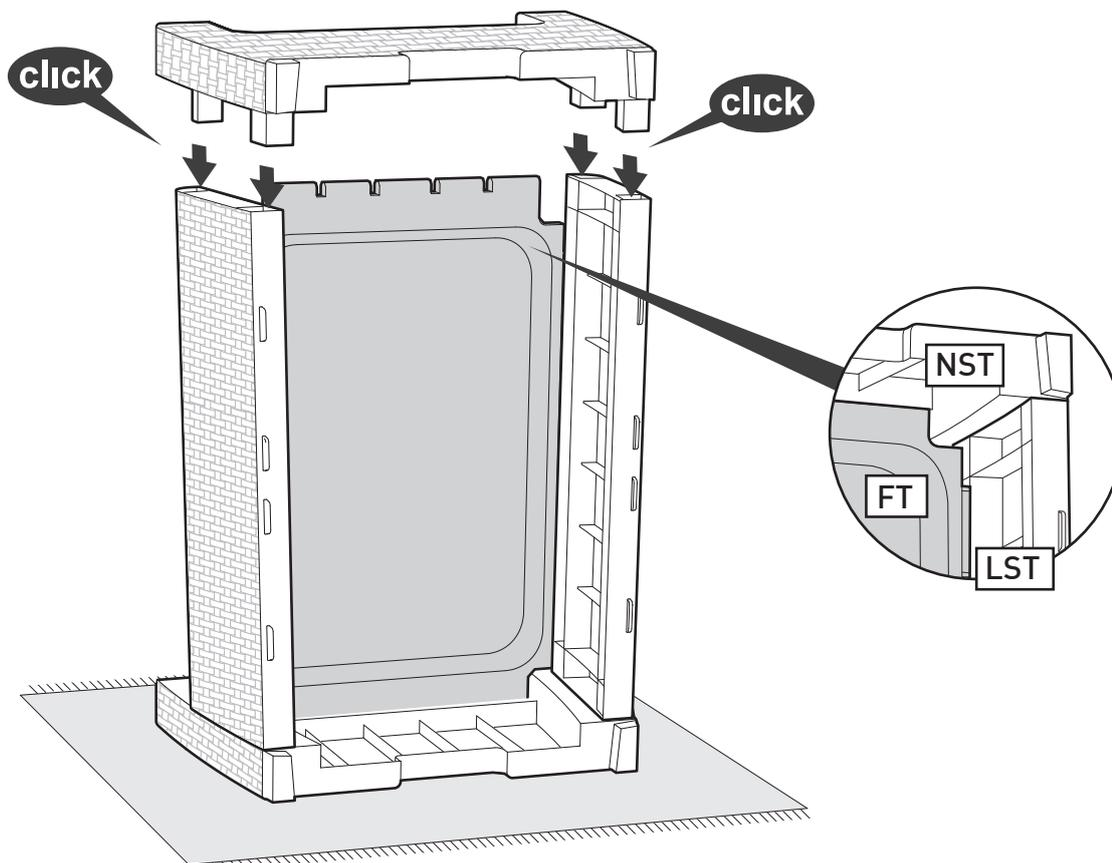

5

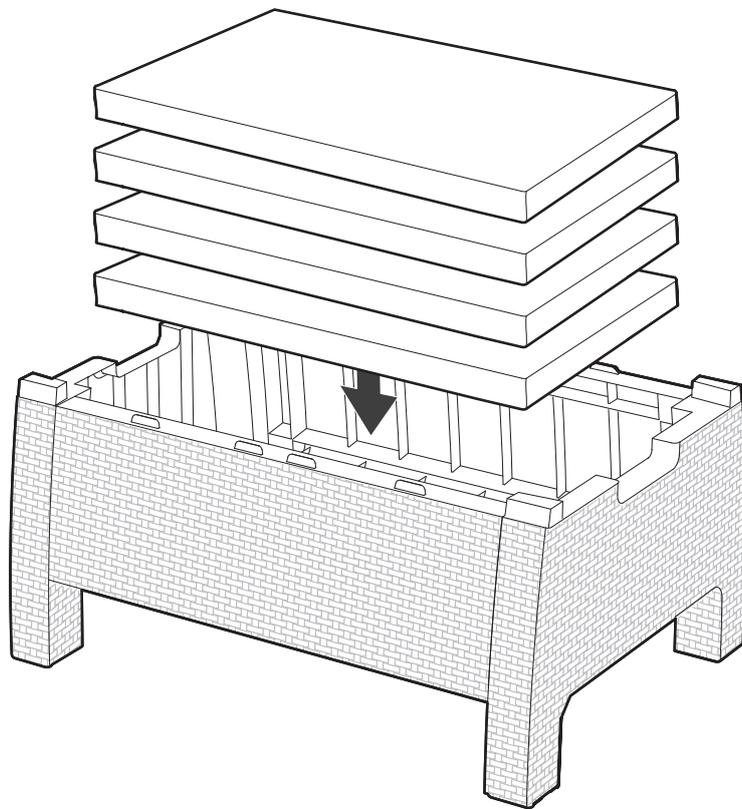

6

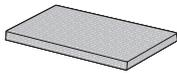

Tx1

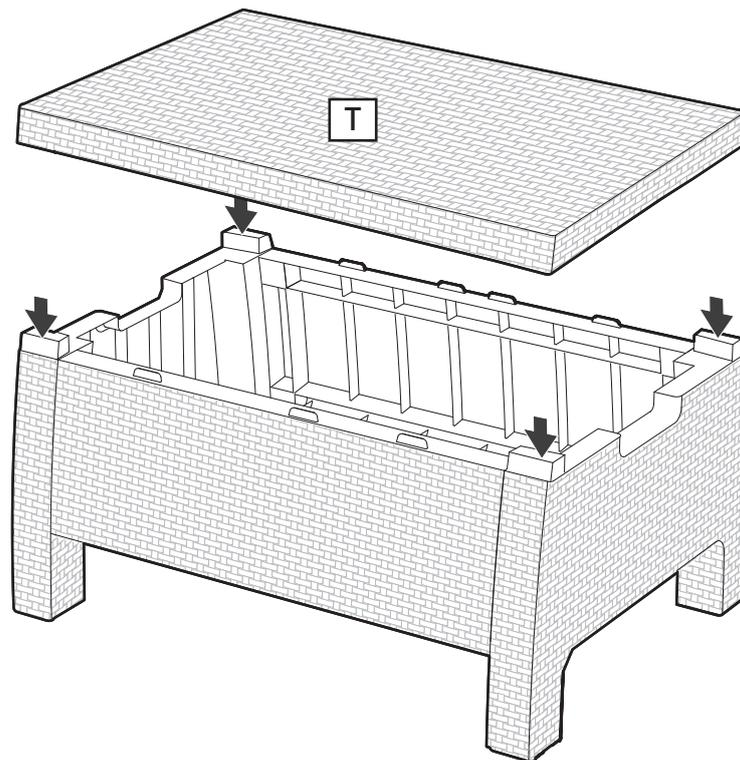

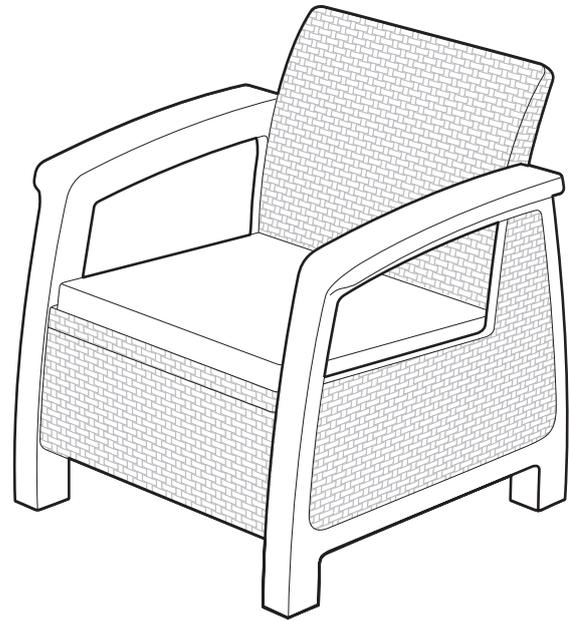
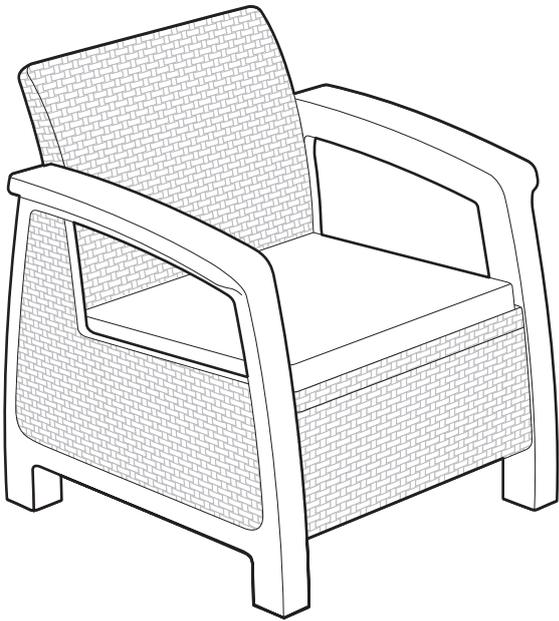
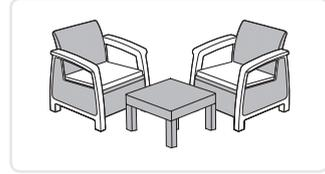
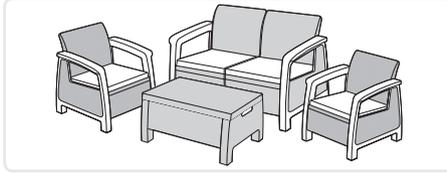
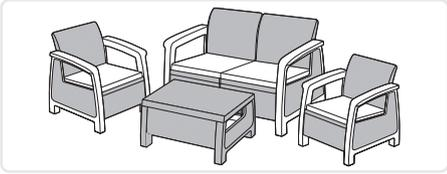

1



Bx1

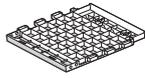

Sx1

X2

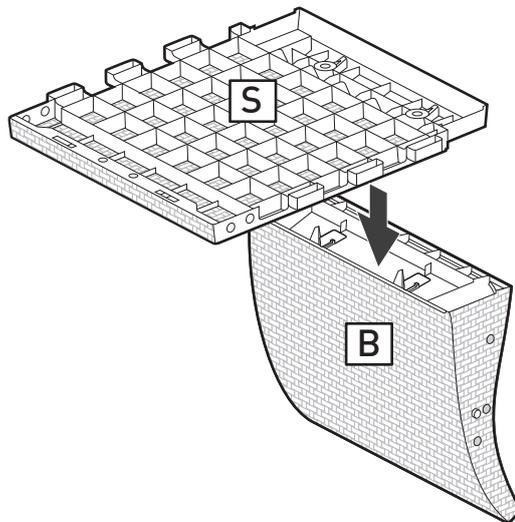

2



LBNx1



RBNx1



SCx2

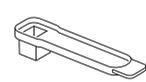

Kx1

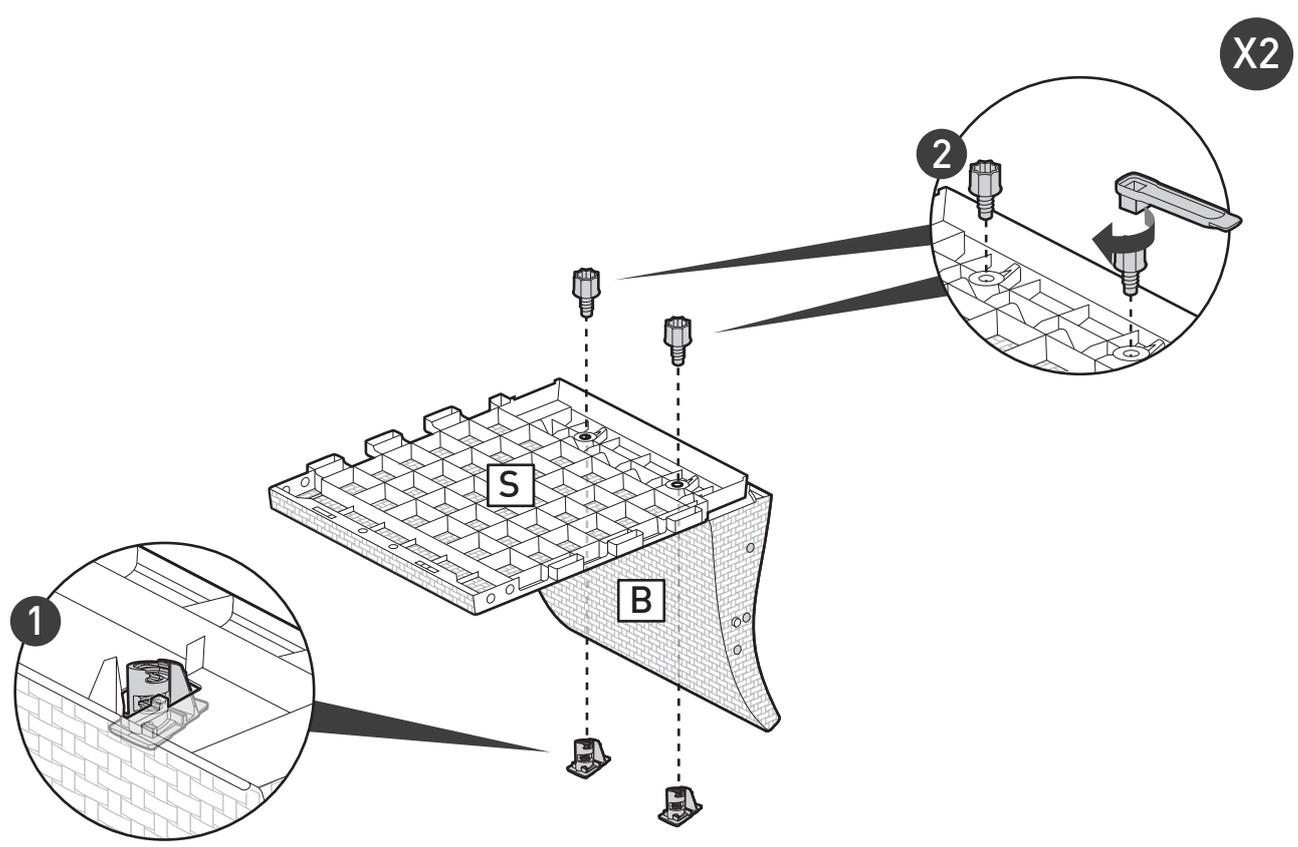

3



FBx1

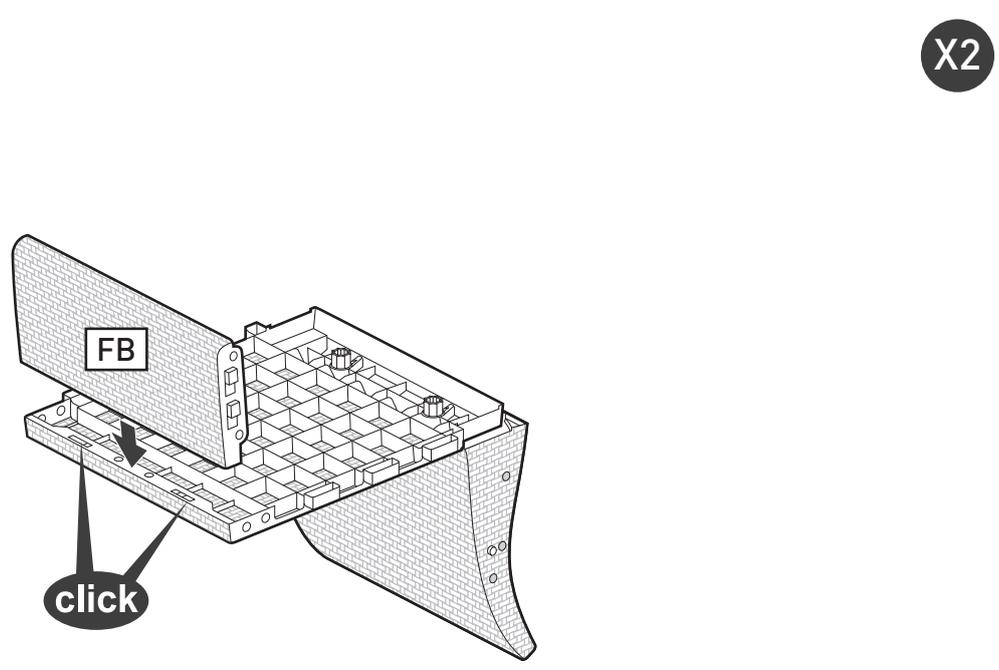

4

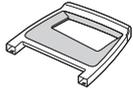

BLSx1



BRSx1



BLx1



BRx1

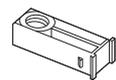

Nx2

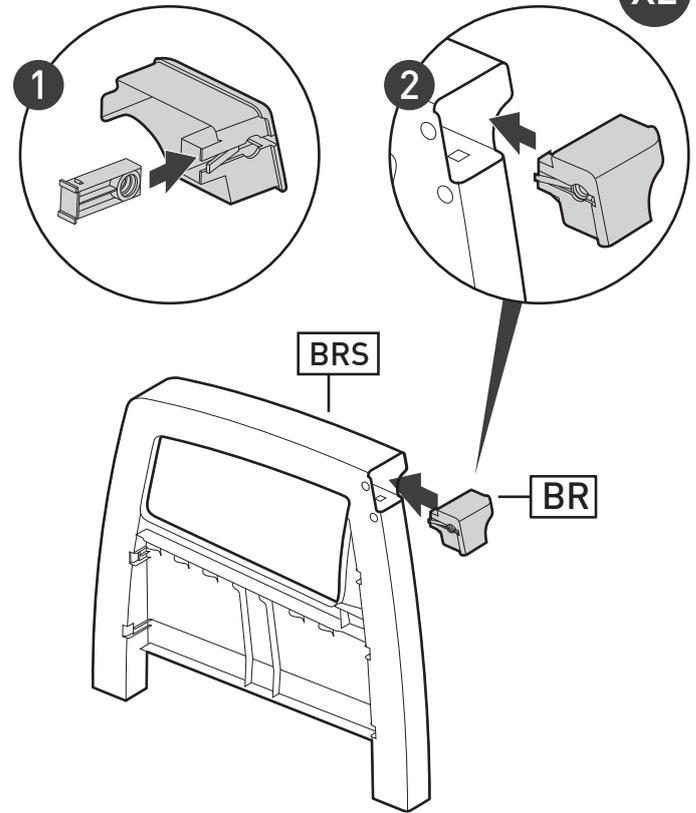
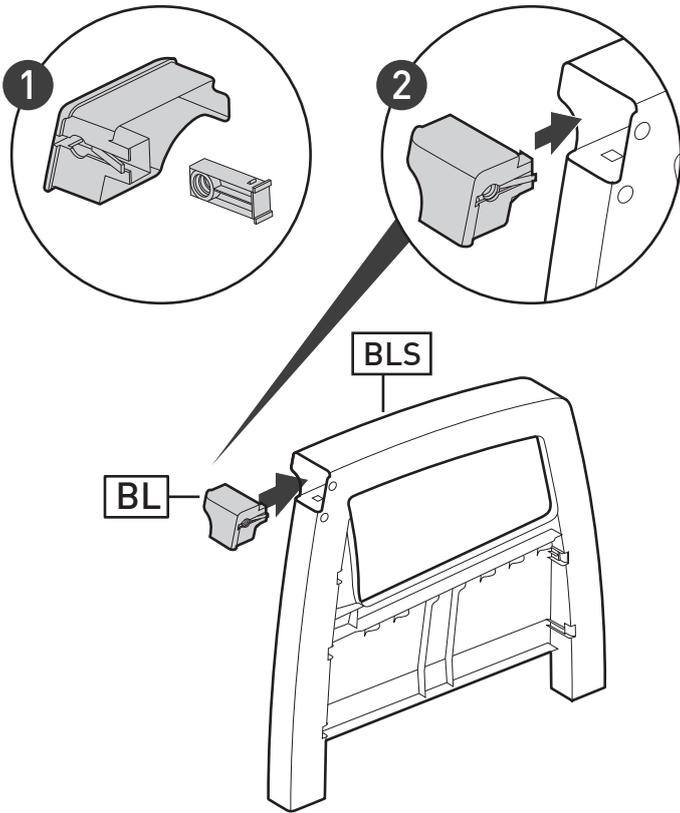

5

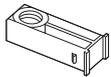

Nx12

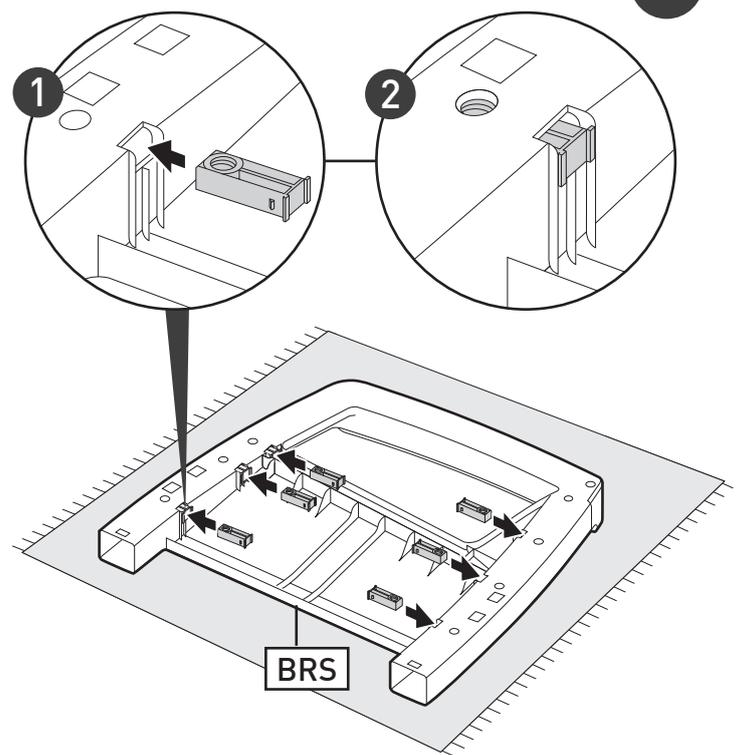
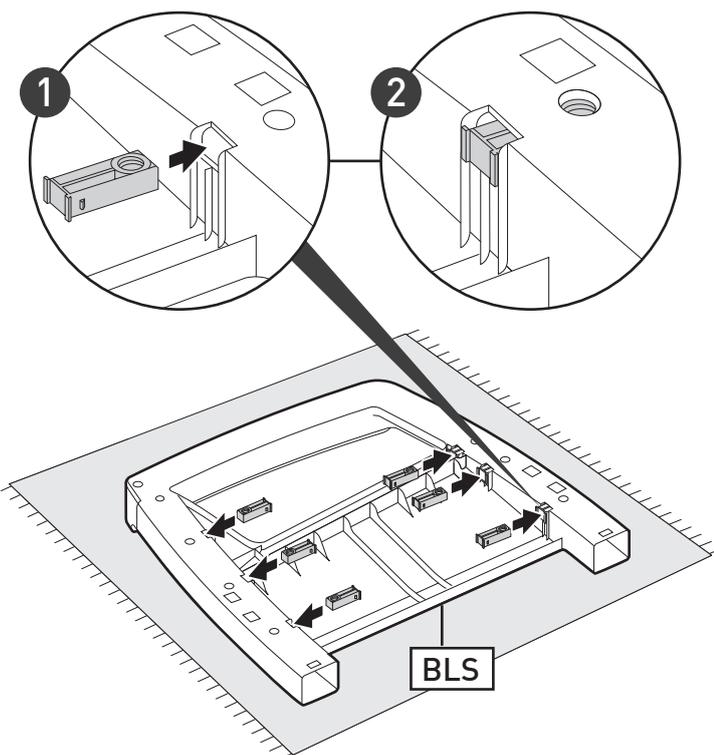

6

X2

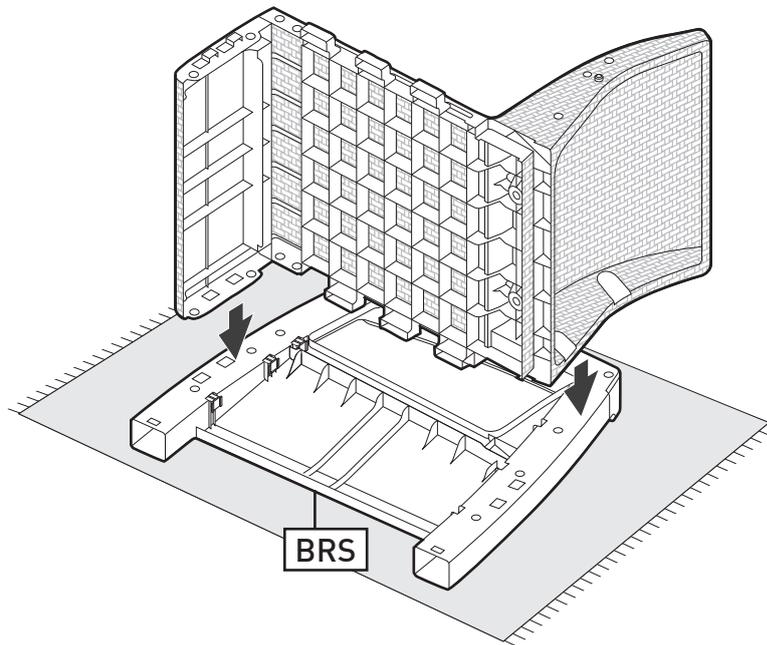

7



FBx1

X2

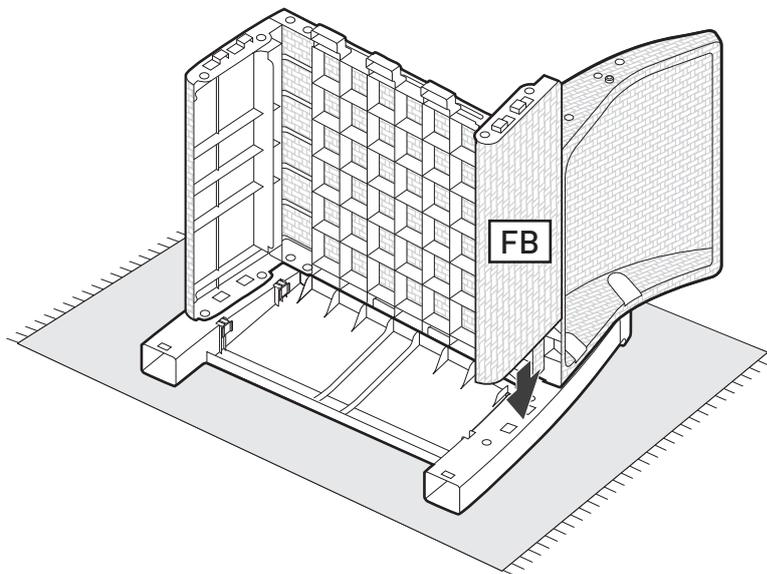

8



x7

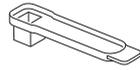

Kx1

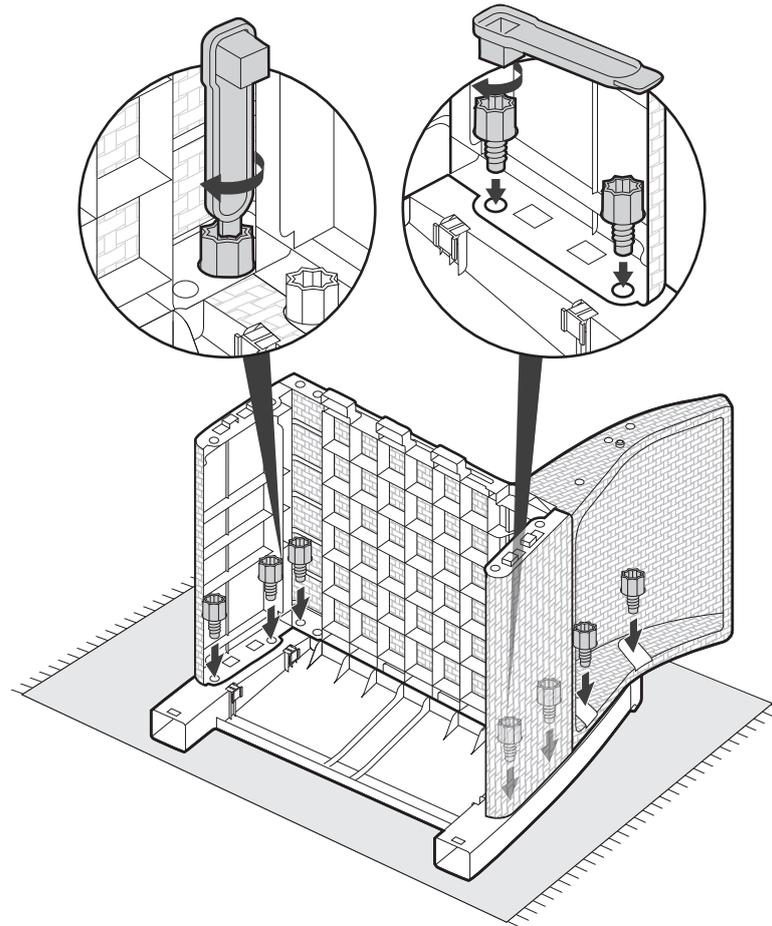

X2

9

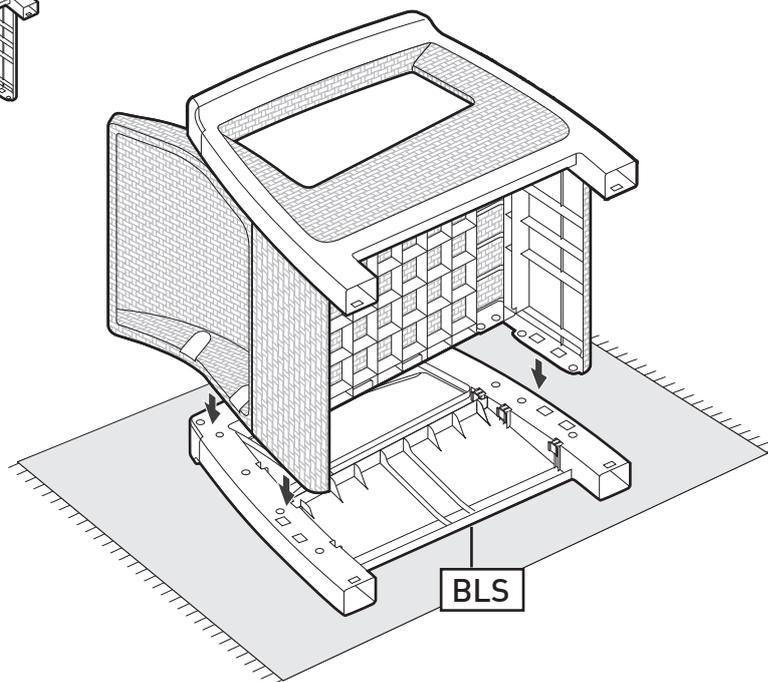
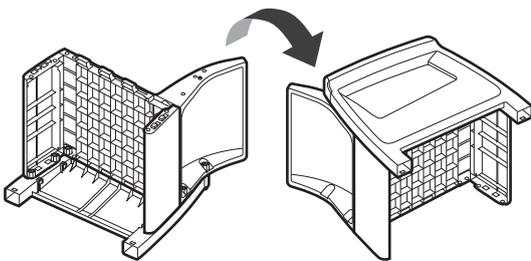

X2

10



SCx7

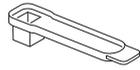

Kx1

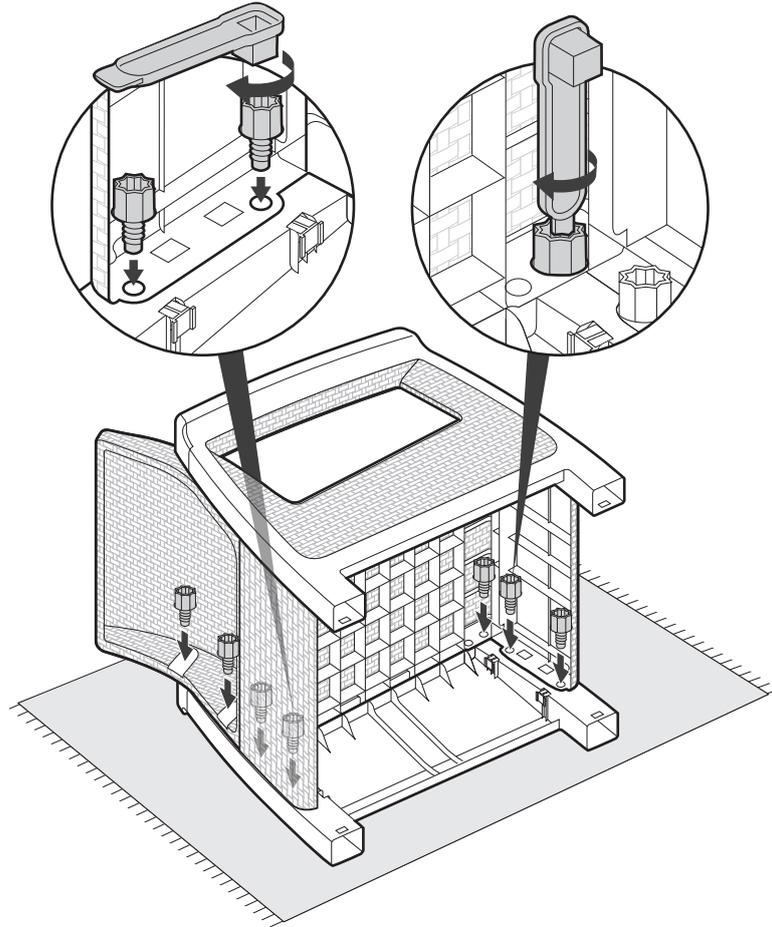

X2

11



BLPx4

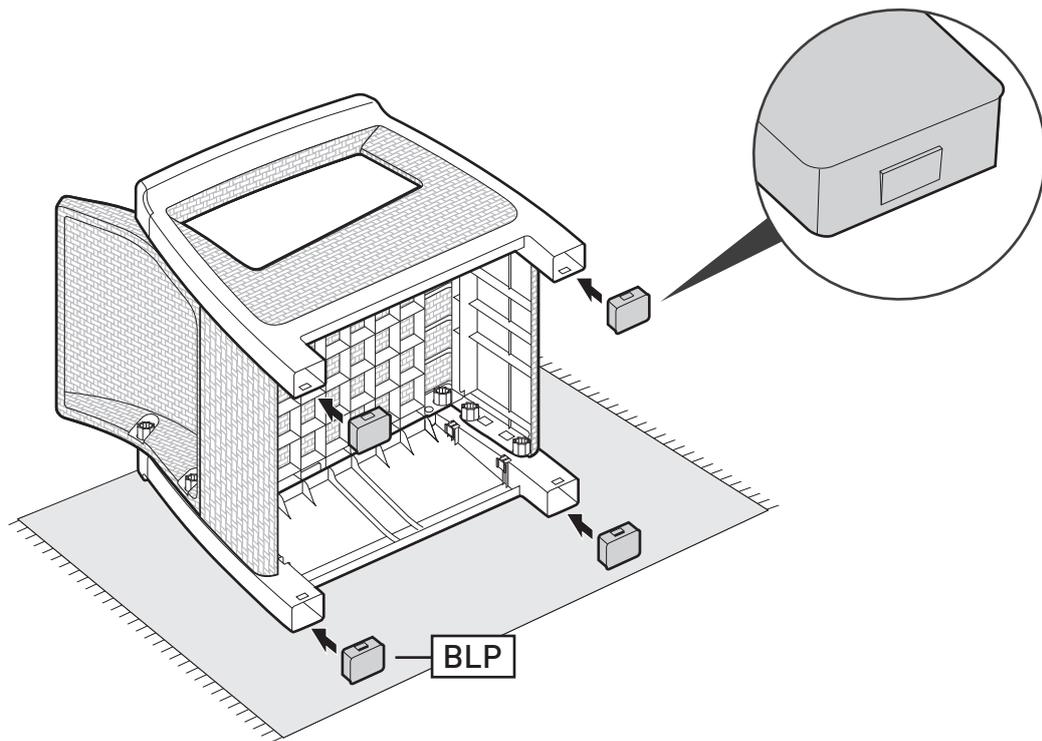

X2

BLP

12



1x1



2x1



3x1



4x1

X2

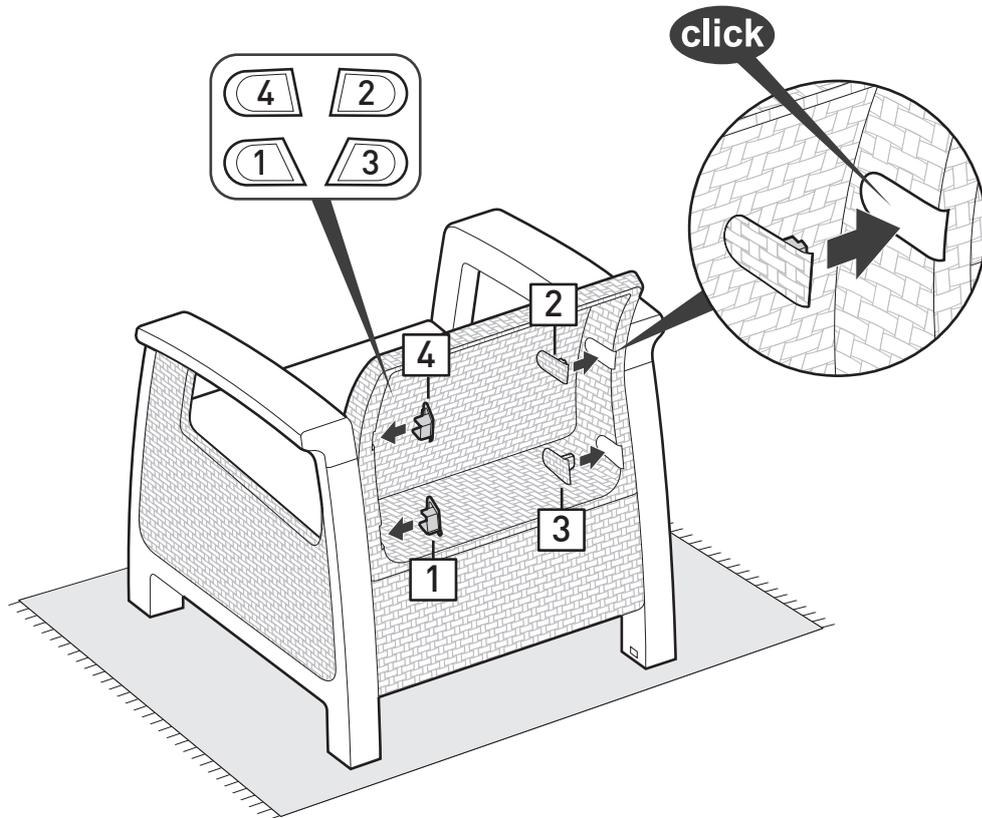

13

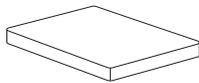

Cx1

X2

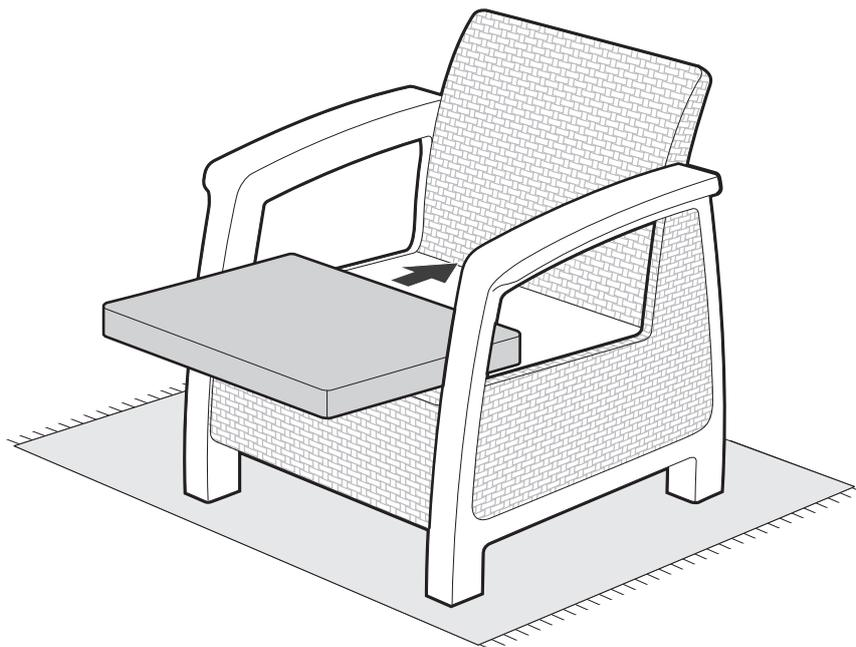

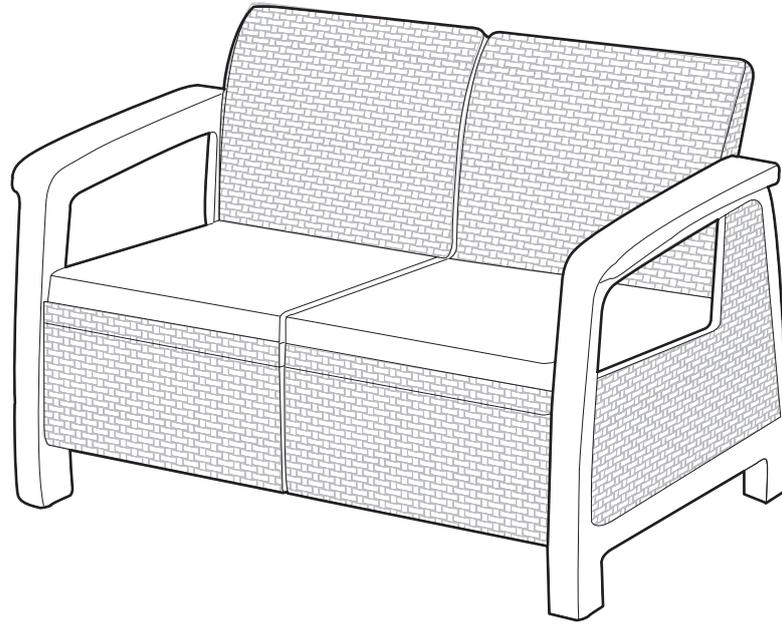
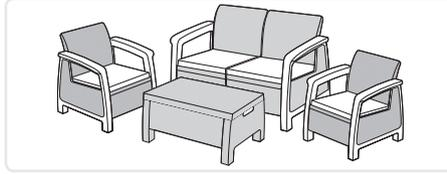
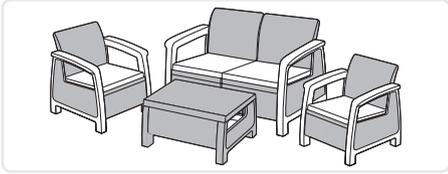

1



Bx2

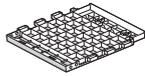

Sx2

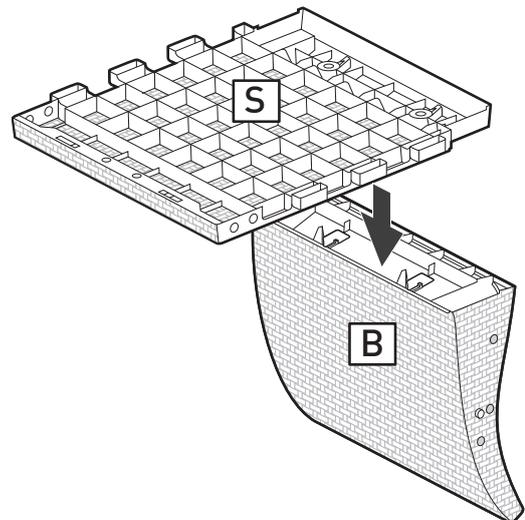
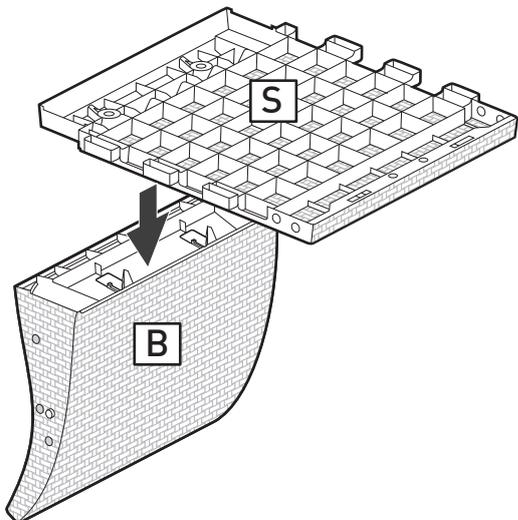

2



LBNx2



RBNx2



SCx4

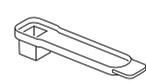

Kx1

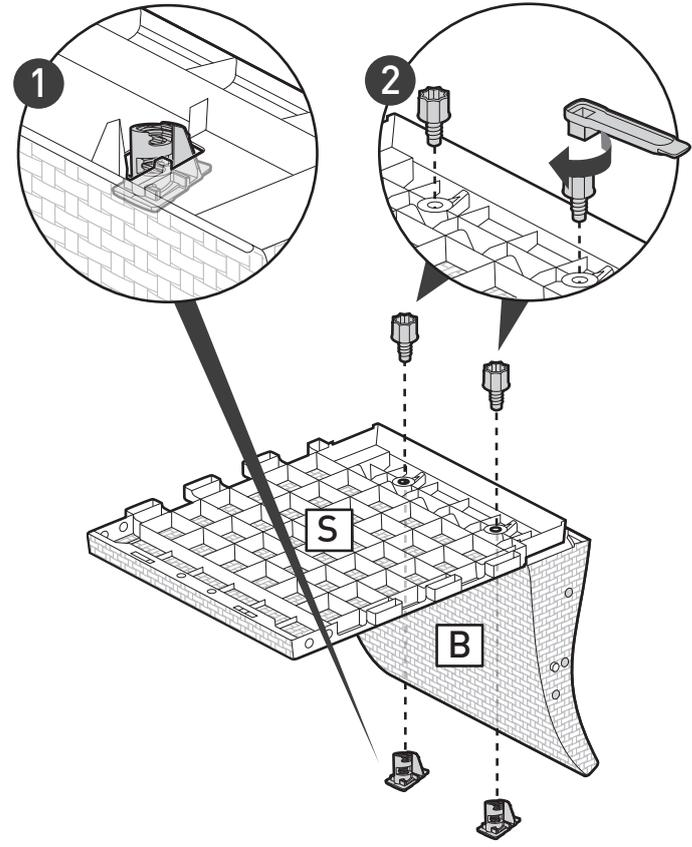
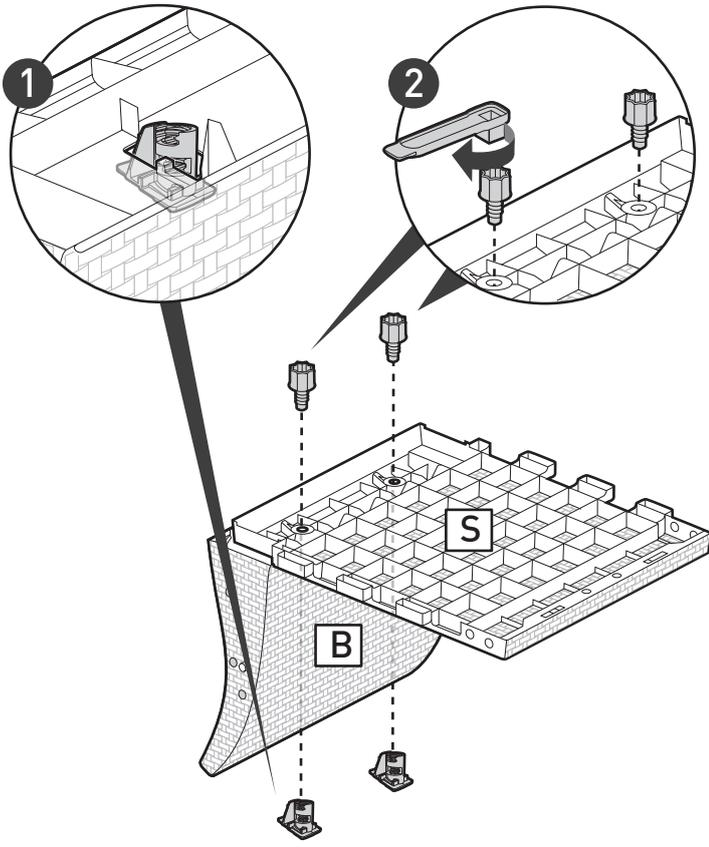

3



FBx2

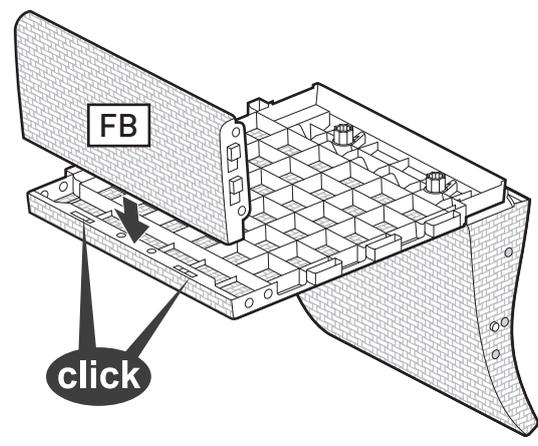
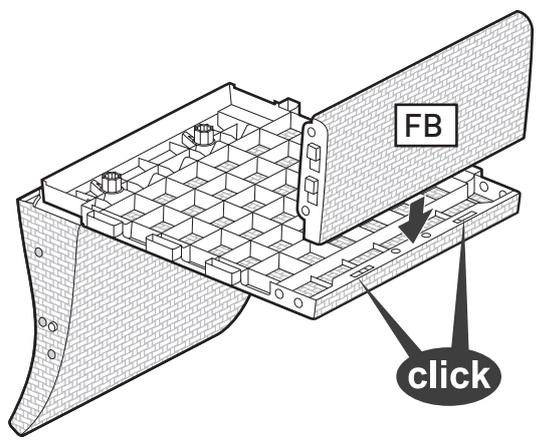

4

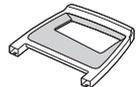

BLSx1

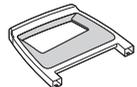

BRSx1



BLx1



BRx1

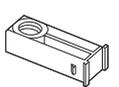

Nx2

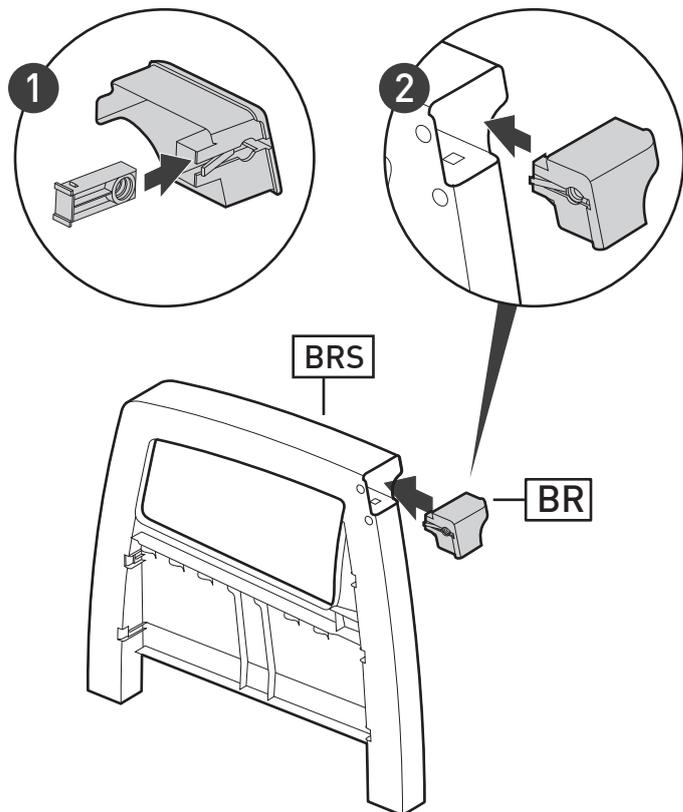
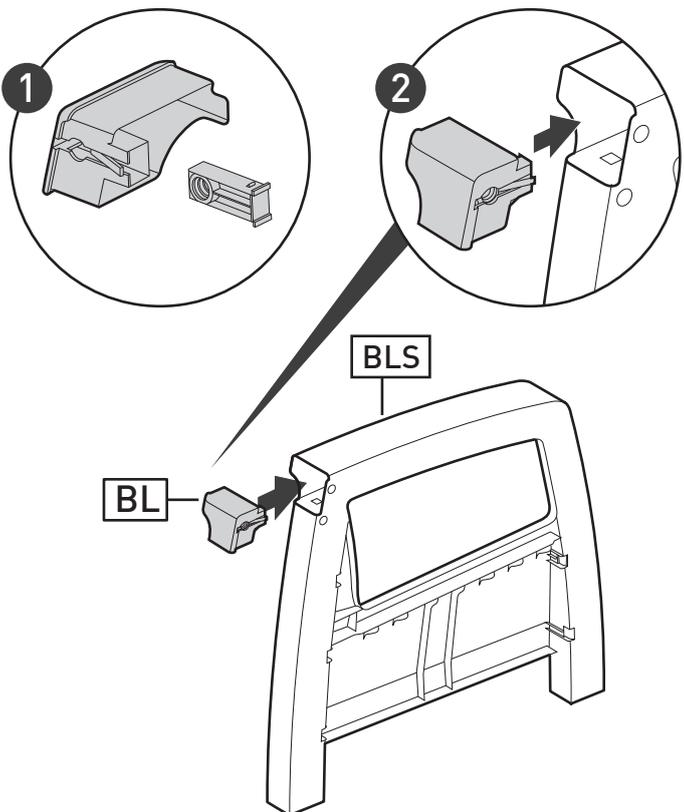

5

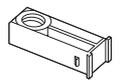

Nx12

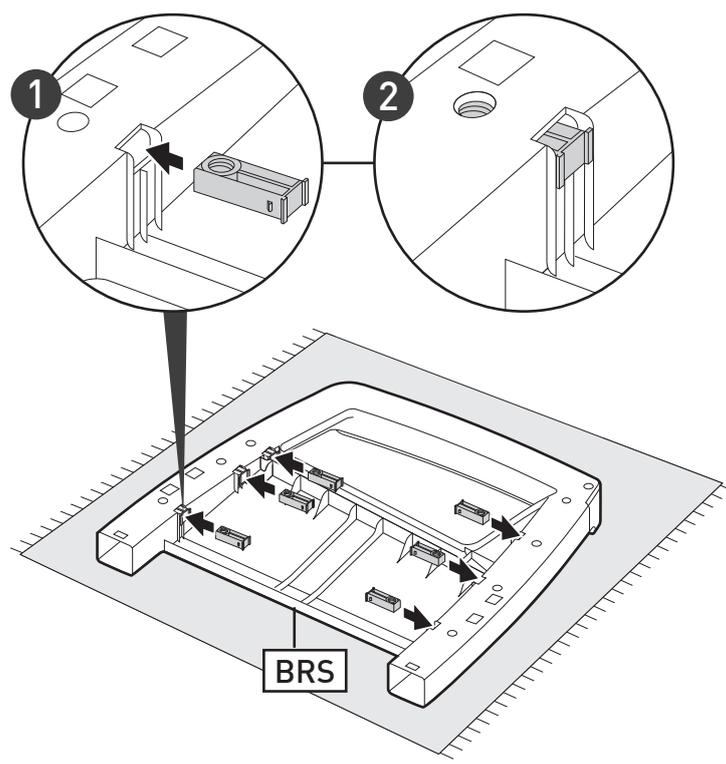
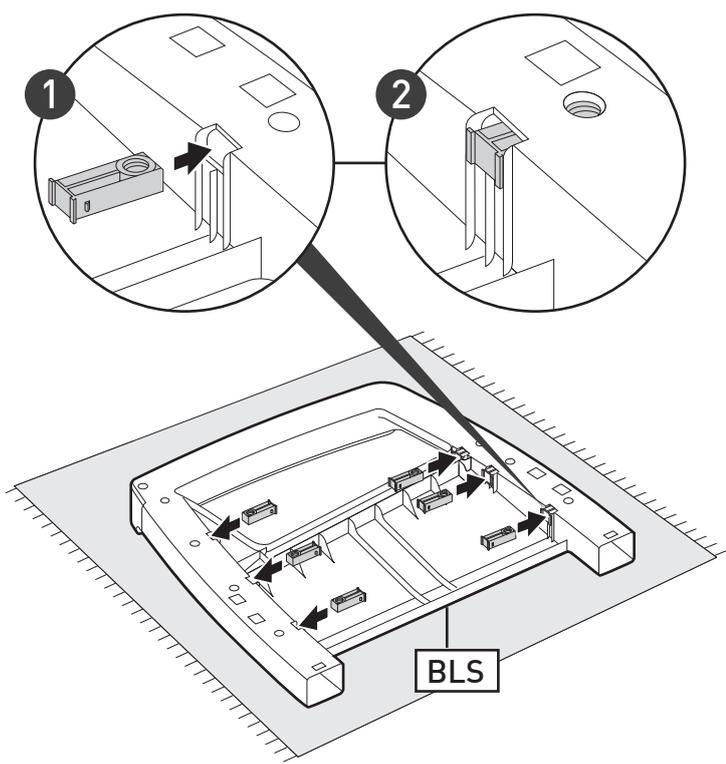

6

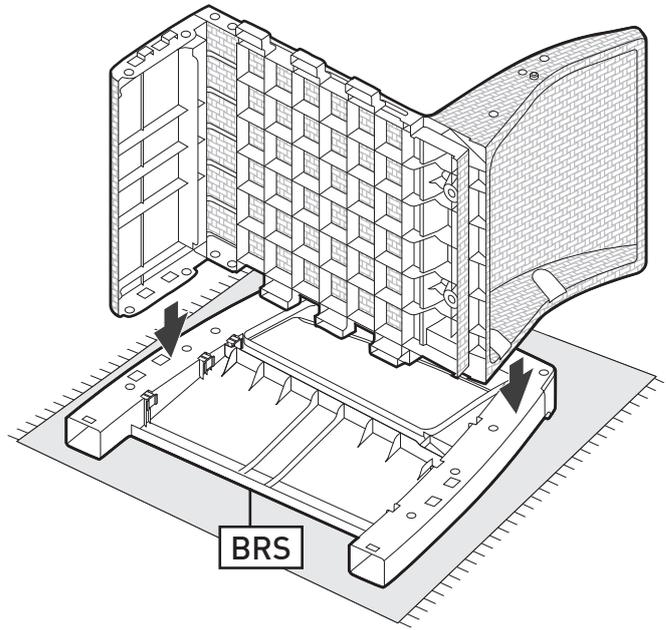
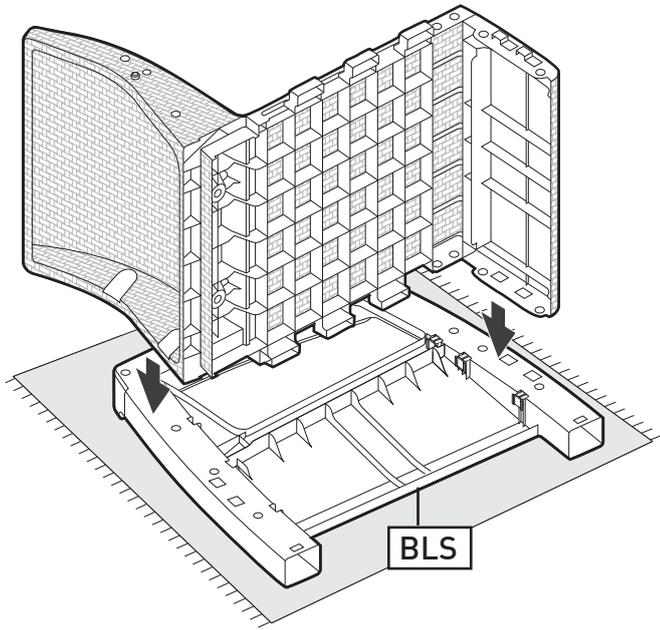

7



FBx2

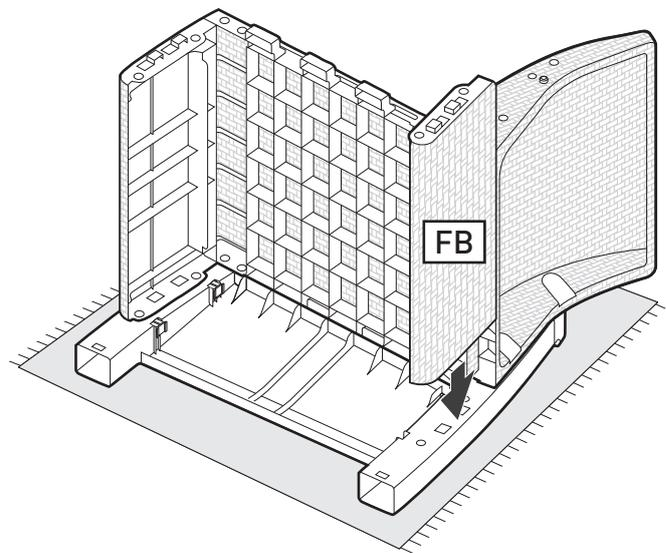
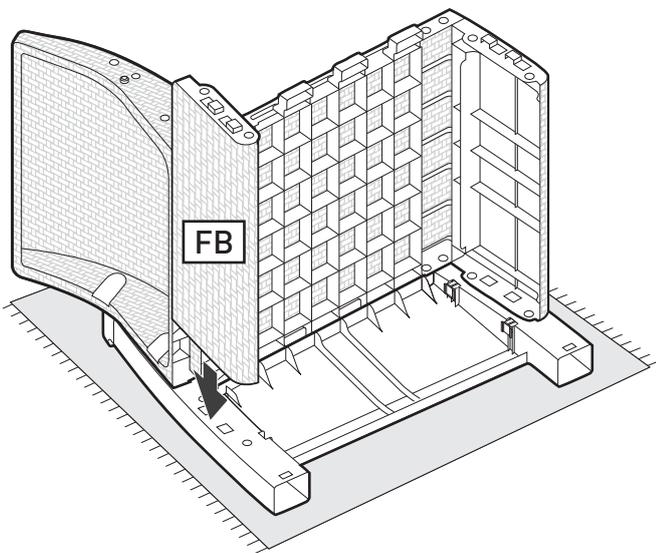

8



SCx14

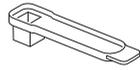

Kx1

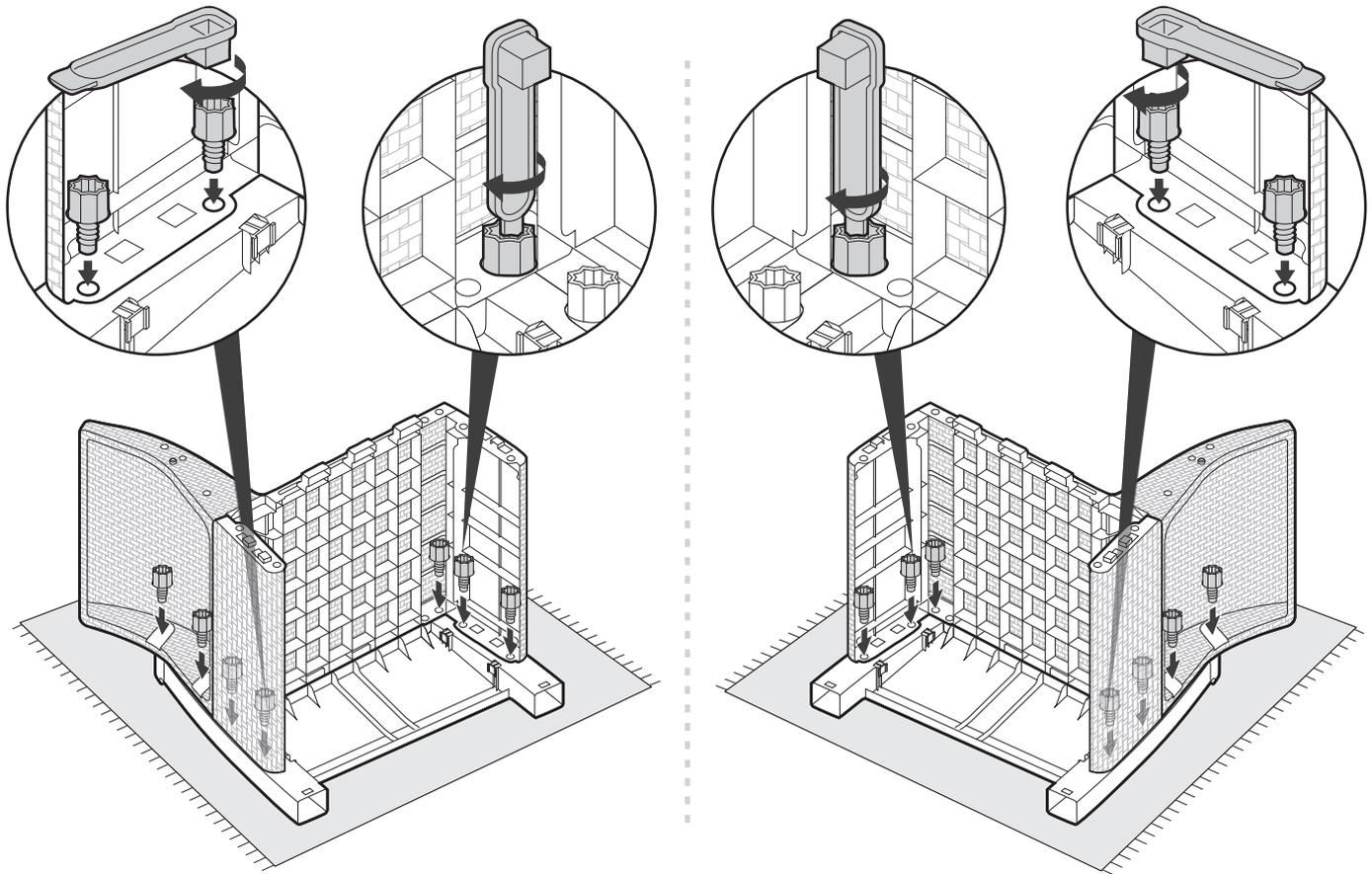

9

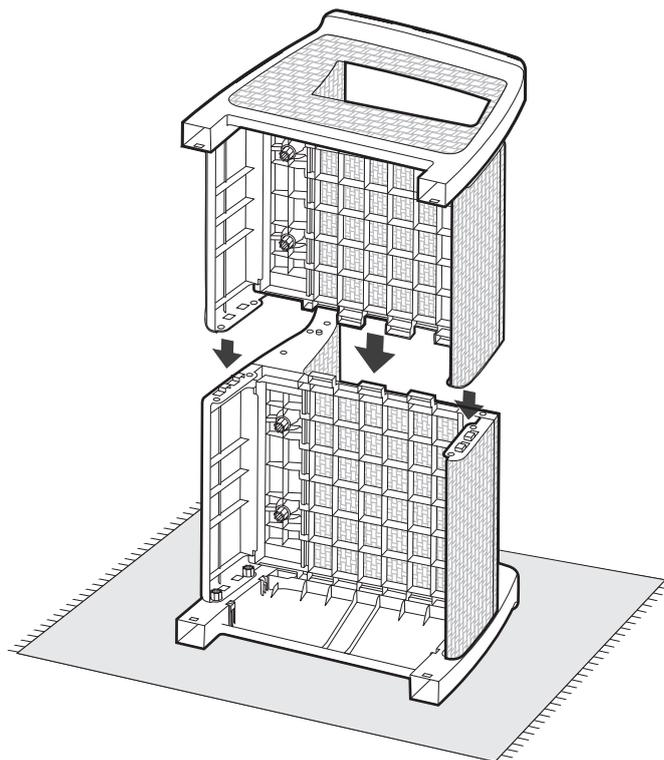

10

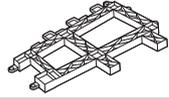

MLx1

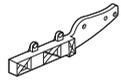

ML1x1

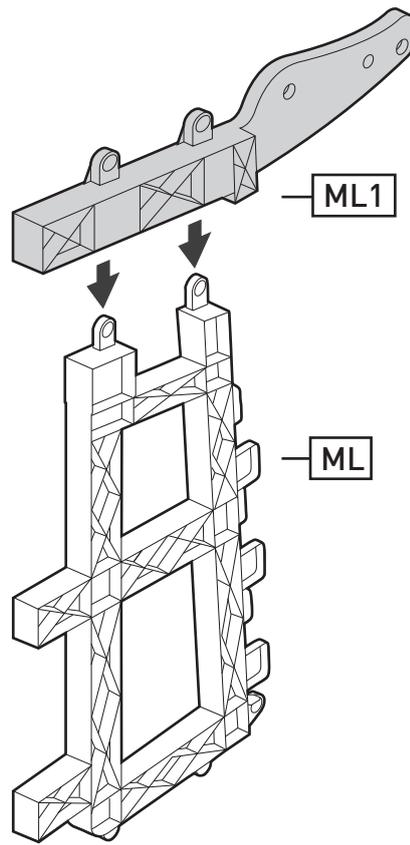

11

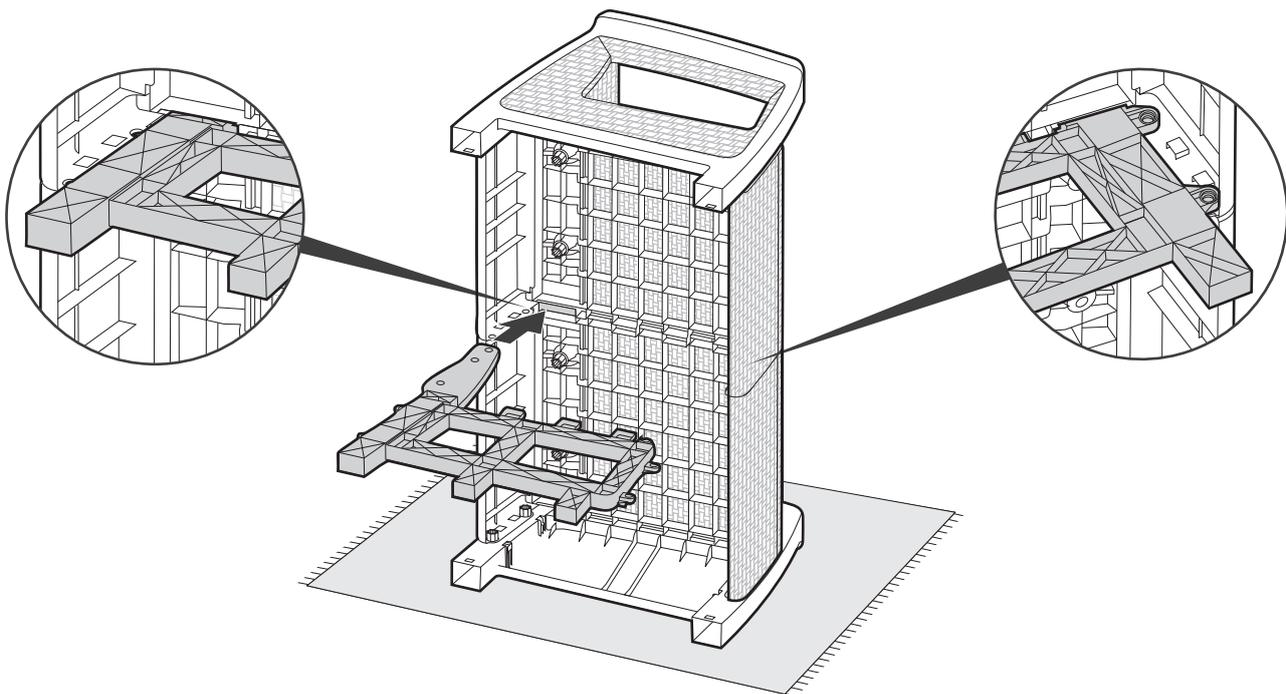

12



SCx7

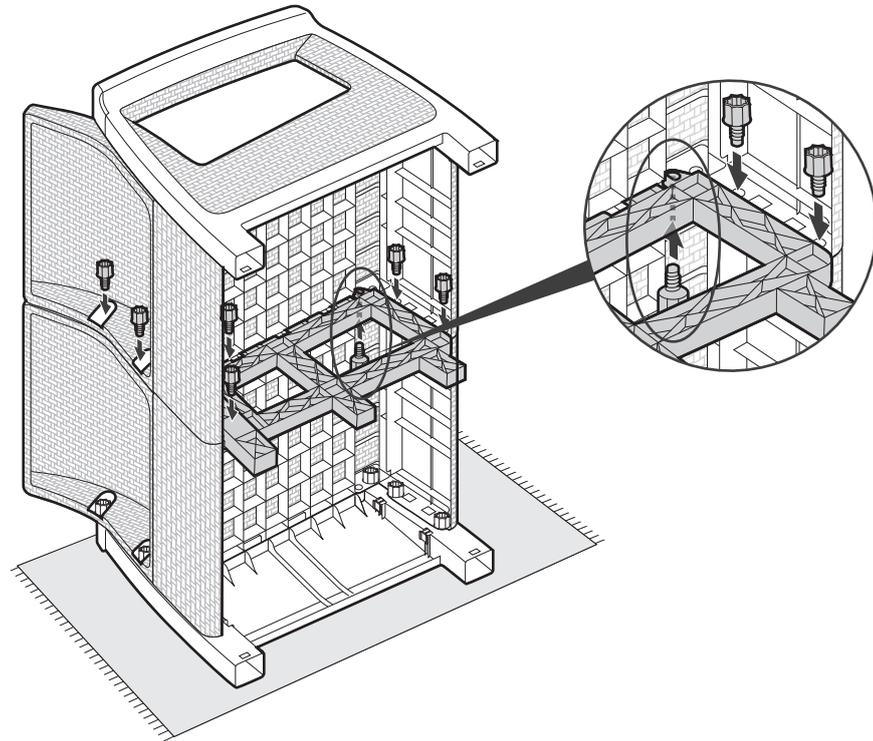

13



BLPx4

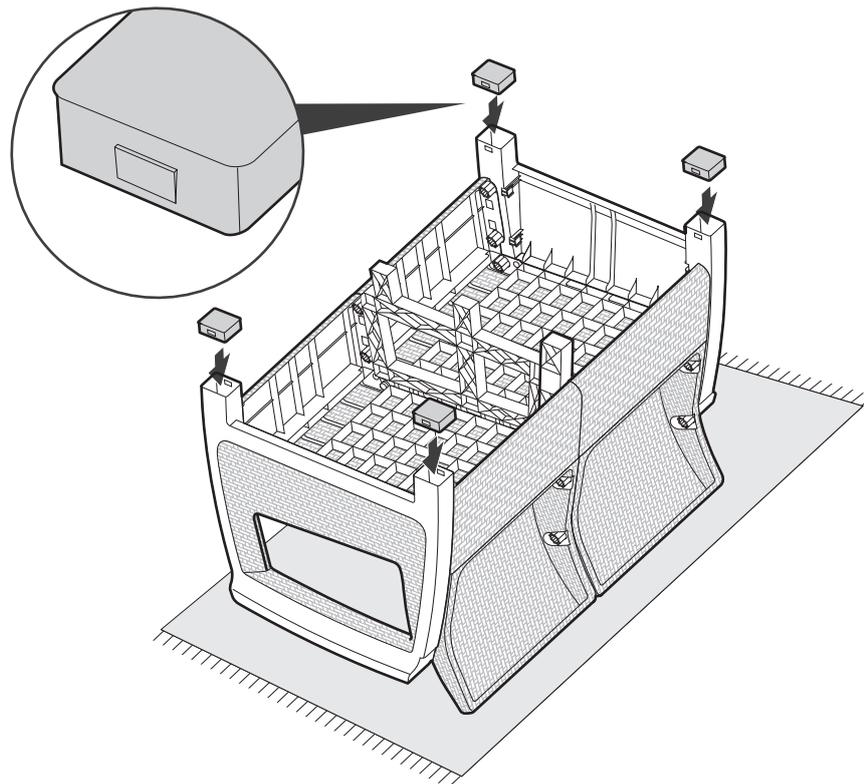

14



1x2



2x2



3x2



4x2

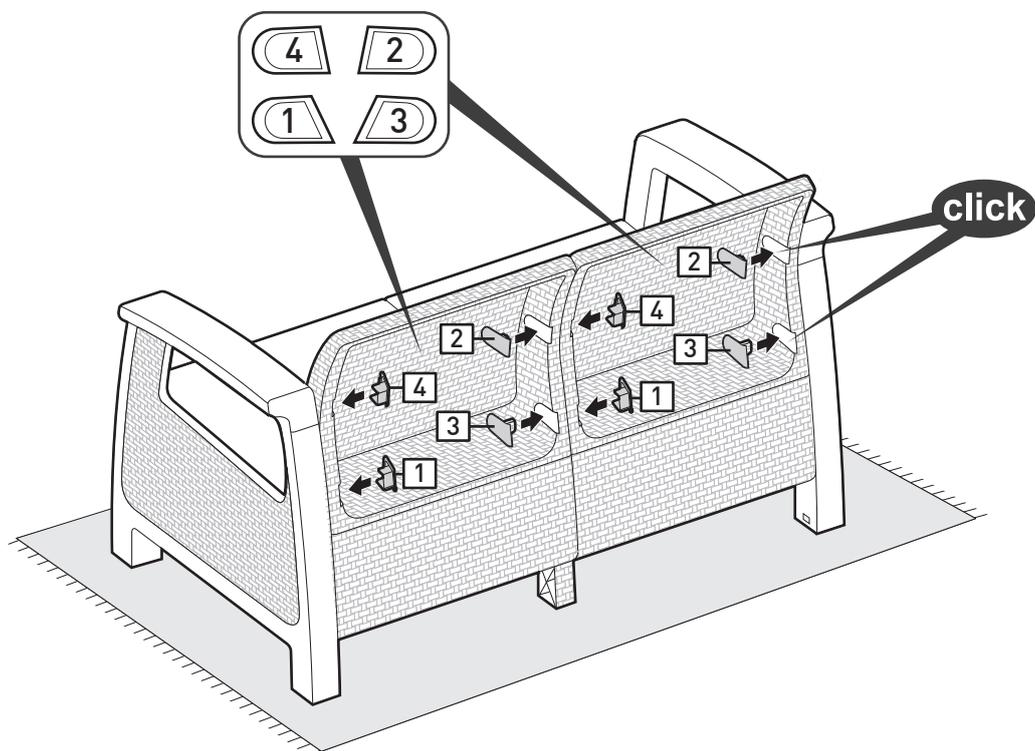

15

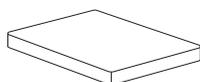

Cx2

