

Assembly Instructions

c: After the sitting test, re - tighten bolts again, if any adjustment needed.

c:

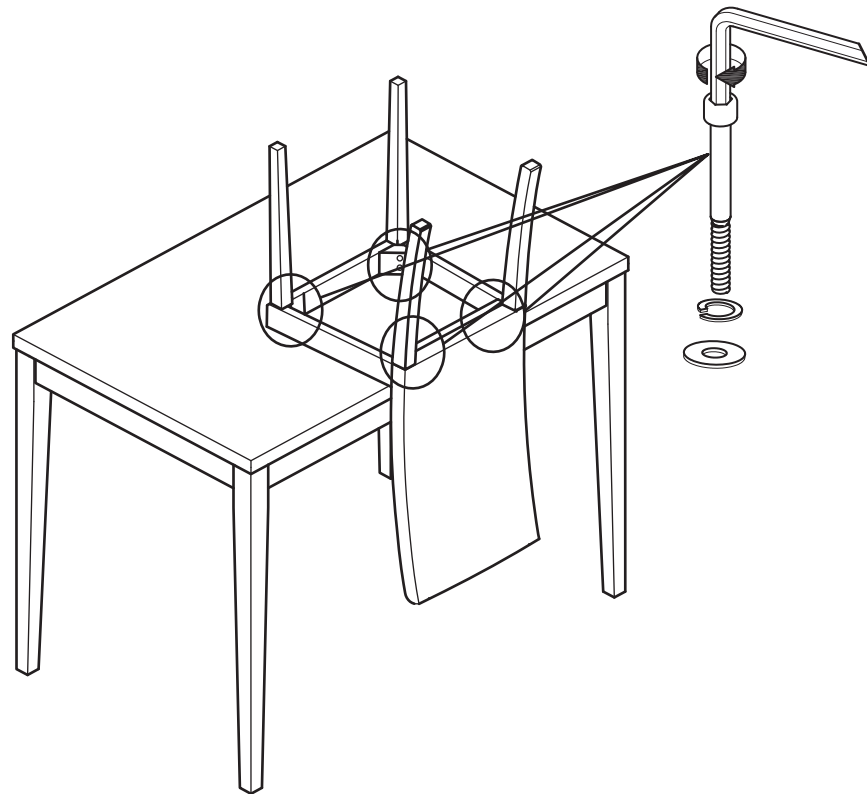

d: It is highly recommend to re - tighten all the bolts again after using the chair for 7 days.

d:

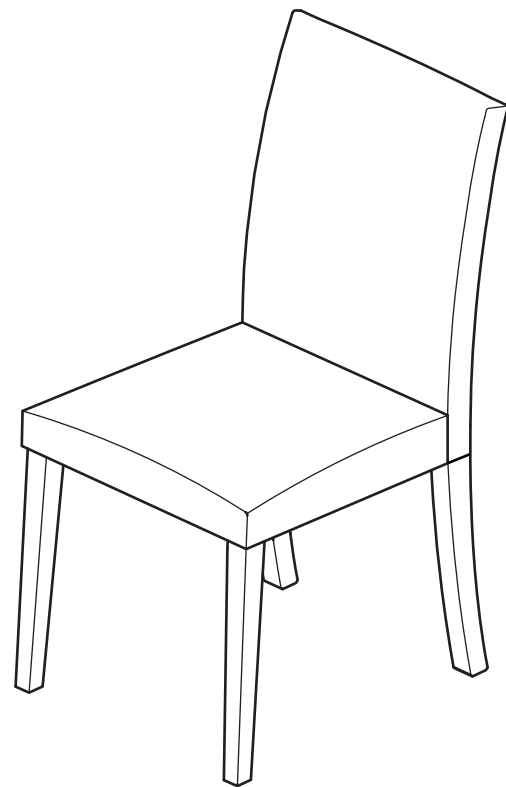

Note : Please keep the allen key to re - tighten all bolts again when required.

Assembly is complete.

If you need help or have damaged or missing parts, call the **Customer Helpline: 0845 6400800**

Winslow Chair

Assembly Instructions - Please keep for future reference

600/1182

600/1199

658/9666

658/9673

658/9680

658/9697

658/9707

658/9721

658/9769

658/9831

658/9848

656/4643

656/4650

632/3372

603/3796

603/3806

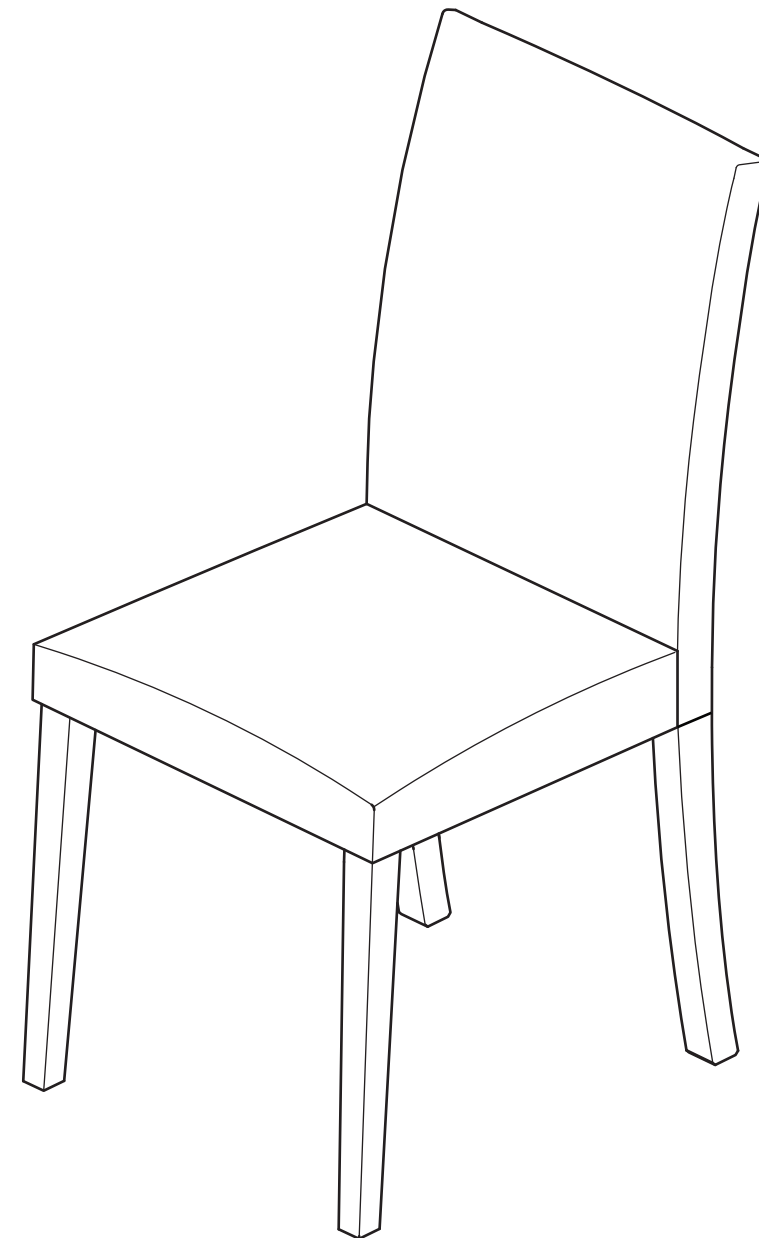

Dimensions

Width - 43cm
Depth - 52.5cm
Height - 85cm

Important – Please read these instructions fully before starting assembly

If you need help or have damaged or missing parts, call the **Customer Helpline: 08456 400800**

Safety and Care Advice

Important – Please read these instructions fully before starting assembly

- Check you have all the components and tools listed on page 2 and 3.

- Remove all fittings from the plastic bags and separate them into their groups.

- Keep children and animals away from the work area, small parts could choke if swallowed.

- Make sure you have enough space to layout the parts before starting.

- Do not stand or put weight on the product during assembly, this could cause damage.

- Assemble the item as close to its final position (in the same room) as possible.

- Assemble on a soft level surface to avoid damaging the unit or your floor.

- Parts of the assembly will be easier with 2 people.



- We do not recommend the use of power drill/drivers **for inserting screws**, as this could damage the unit. Only use hand screwdrivers.

- Dispose of all packaging carefully and responsibly.

- Maximum safe weight of user: 110 Kgs.

Care and maintenance

- Only clean using a damp cloth and mild detergent, do not use bleach or abrasive cleaners.

- From time to time check that there are no loose screws on this unit.

- This product should not be discarded with household waste. Take to your local authority waste disposal centre.

Assembly Instructions

Step 2

Note : Stand the chair on a level floor.

a: Tightly screw all bolts.

Note : Step 2 is essential to prevent the chair from wobbling due to legs uneven.

a:

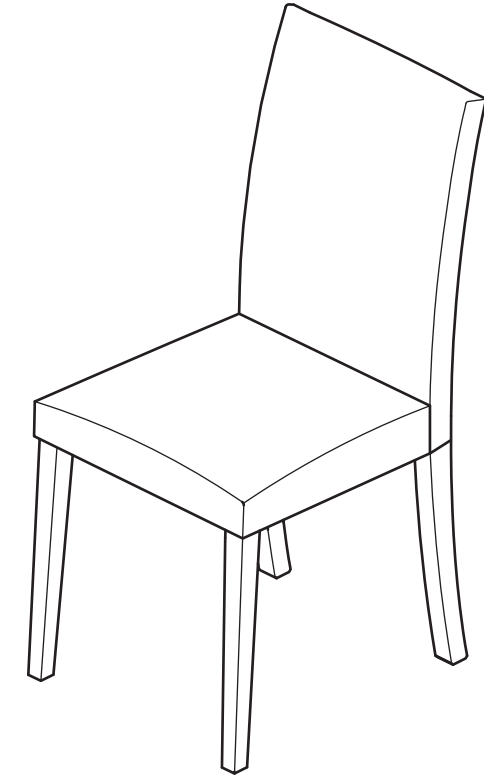

b: Sit on the chair to level the legs.

b:

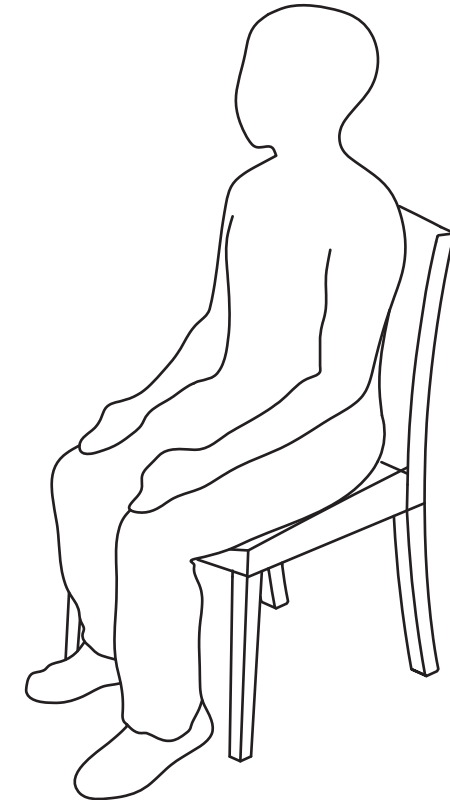

Assembly Instructions

C: Turn over the chair. Put legs **3** into front corners of the seat frame **2**. Insert bolts **A** with spring washers **B** and washers **C** into each of the 2 holes in the front corners. Tighten bolts with allen key **E**.

Do not fully tighten.

C:

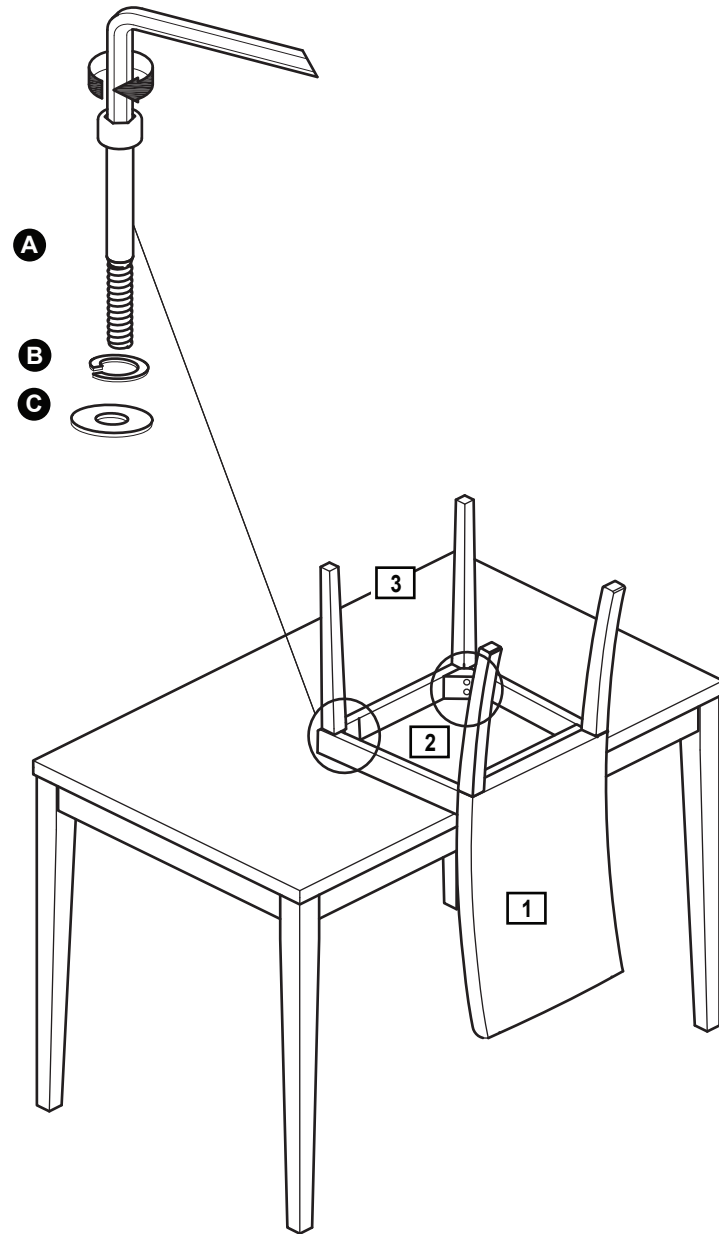

Components - Parts

If you have damaged or missing components, call the **Customer Helpline: 08456 400800**

Please check you have all the parts listed below

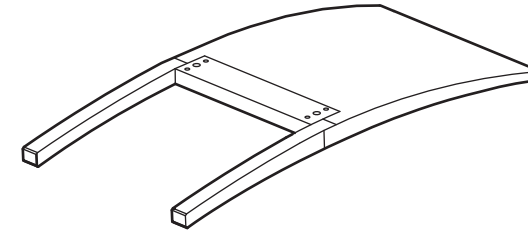

1 Chair back x 1

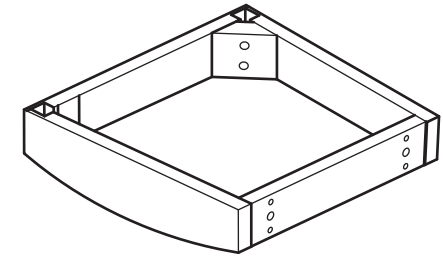

2 Seat x 1

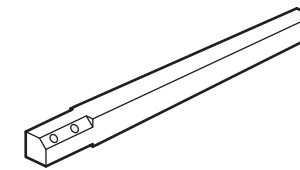





3 Leg x 2

Components - Fittings

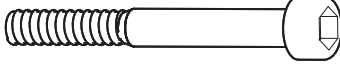
Please check you have all the fittings listed below

Note: The quantities below are the correct amount to complete the assembly. In some cases more fittings may be supplied than are required.

A  Bolt x 8	B  Spring washer x 8	C  Washer x 8
D  Wooden dowel x 2	E  Allen key x 1	

Assembly Instructions

Step 1

a: Insert wooden dowels **D** into each centre hole in the back of the seat **2**.

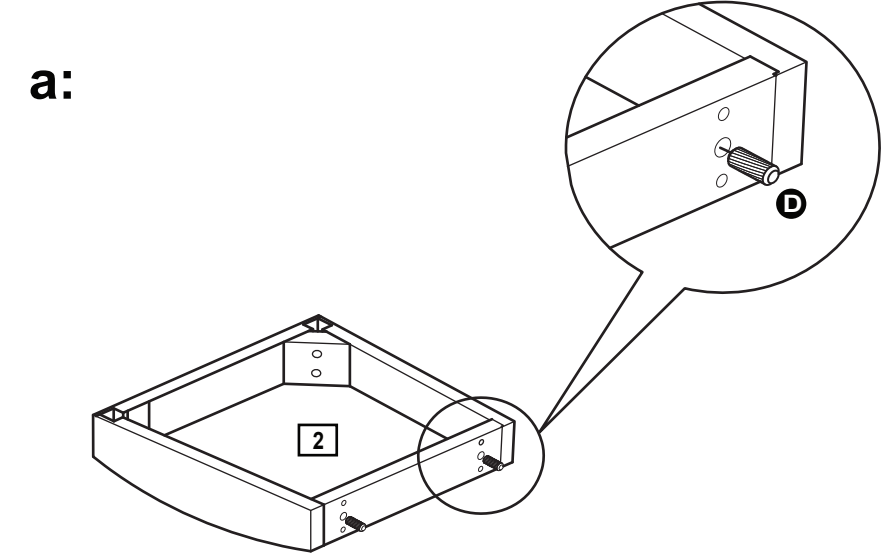

b: Insert bolts **A** with spring washers **B** and washers **C** through the holes at the back of the seat **2** into the chair back **1**. Tighten bolts with allen key **E**.

Do not fully tighten.

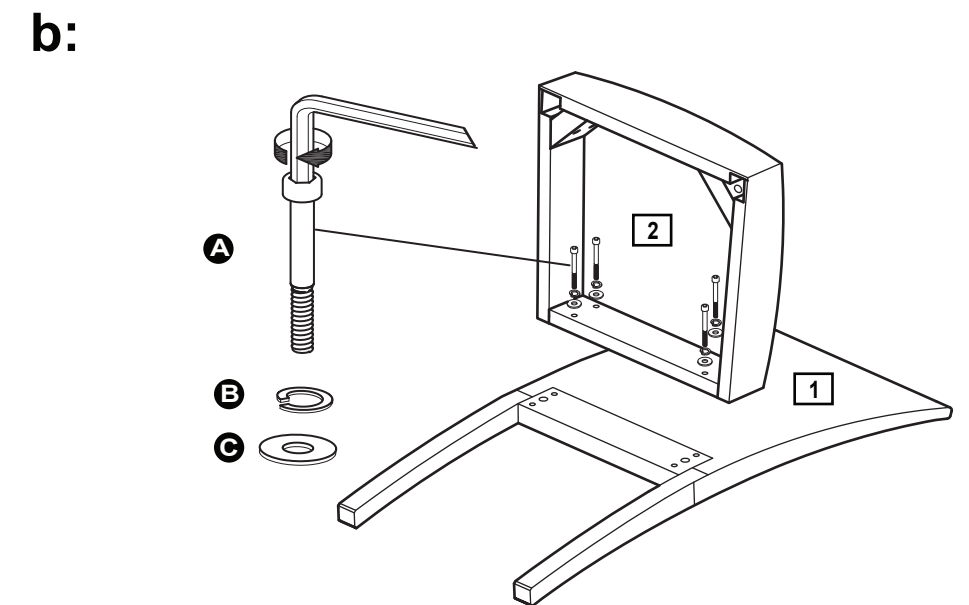

Dining Chair

Assembly Instructions - Please keep for future reference

603/3796

603/5213

603/5189

603/3806

603/5196

603/5237

603/5172

603/5206

603/5220

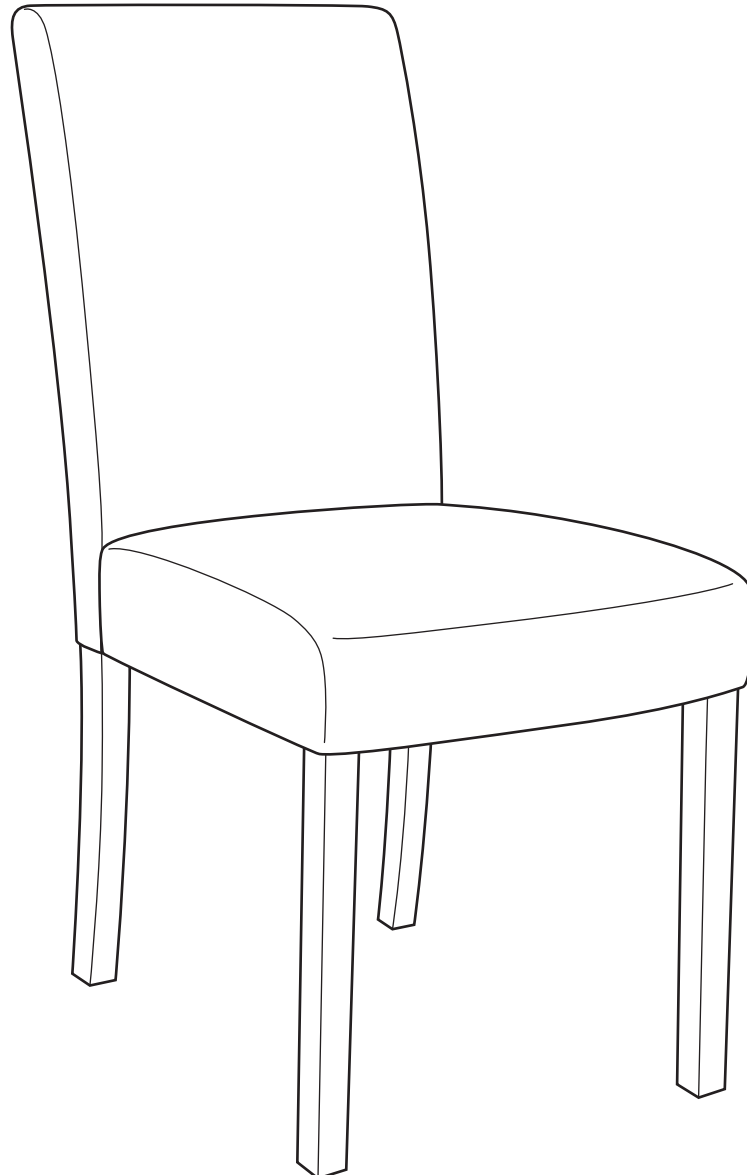

Dimensions

Width - 44cm

Depth - 54cm

Height - 86cm

Important - Please read these instructions fully before starting assembly

If you need help or have damaged or missing parts, call the **Customer Helpline: 08456 400800**



Safety and Care Advice

Important - Please read these instructions fully before starting assembly

- Assemble this product on a flat surface.
- Assemble all parts loosely before tightening any bolts.
- Do not discard any of the packaging until you have checked that you have all the parts and the pack of fittings.

- Discard all extra fittings and keep fittings out of reach of children.
- Unit weight: 4.9kgs.
- Maximum safe weight of user: 110kgs.
- Retain Assembly Instructions for future reference.



- We do not recommend the use of power drill/drivers **for inserting screws**, as this could damage the unit. Only use hand screwdrivers.
- Dispose of all packaging carefully and responsibly.

Warnings

- This product should only be used on firm, level ground.
- Make sure the legs remain in contact with the ground.
- Do not stand on the product.

Care and maintenance

- Please clean the unit surface using either damp (not wet) cloth and a mild domestic soap solution or by using an appropriate polish.
- Do not use any abrasive materials when cleaning.
- From time to time check that there are no loose bolts on this unit.

Components - Parts

If you have damaged or missing components, call the **Customer Helpline: 08456 400800**

Please check you have all the parts listed below

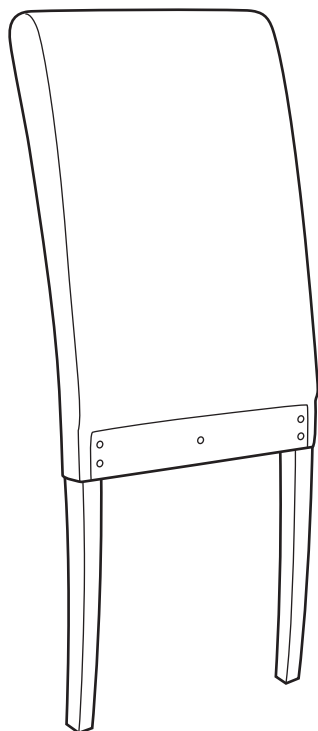

1 Backrest
(36 x 10 x 86cm)

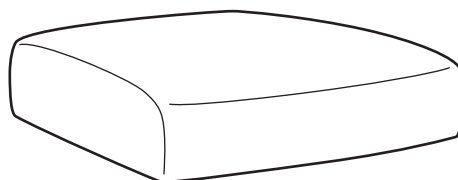

2 Seat
(43.5 x 41 x 9.5cm)

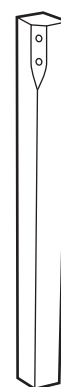





3 Leg x 2
(3 x 3 x 43cm)

Components - Fittings

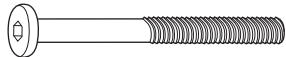
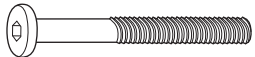
Please check you have all the fittings listed below

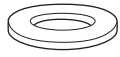
Note: The quantities below are the correct amount to complete the assembly. In some cases more fittings may be supplied than are required.

<p>A </p> <p>M6 x 85mm Bolt x 4</p>	<p>B </p> <p>M6 x 55mm Bolt x 5</p>	<p>C </p> <p>Spring washer x 9</p>
<p>D </p> <p>Washer x 9</p>	<p>E </p> <p>Allen key x 1</p>	

Ruler - Use this ruler to help correctly identify the screws

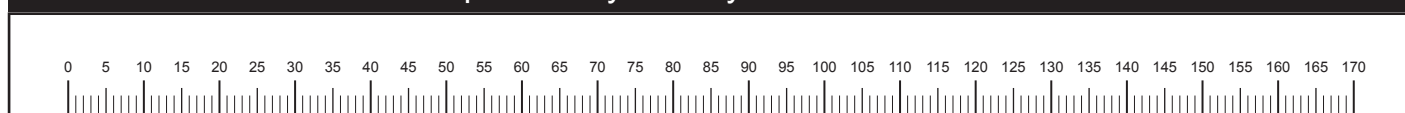

Assembly Instructions

Step 1

Attaching legs

Place the seat **2** upside down on a flat protected surface.

Insert the legs **3** into the holes of the seat as shown and fix using bolts **B**, spring washer **C** and washers **D**.



Important:

Fasten bolts using allen key **E** but do not fully tighten at this stage.

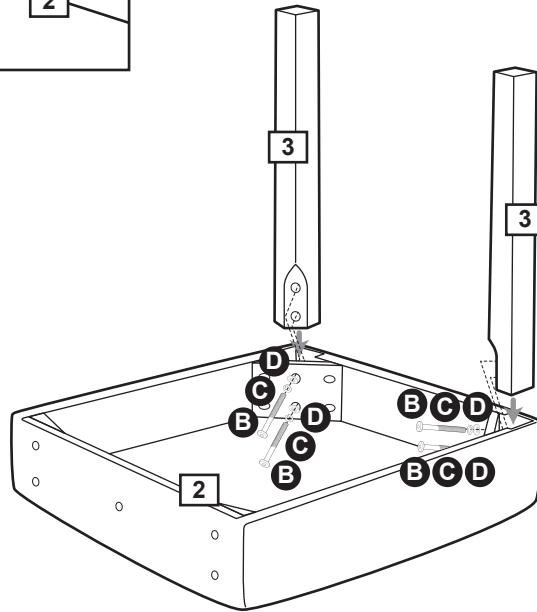
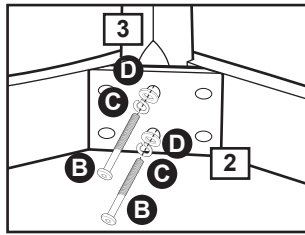

Step 2

Attaching backrest

Place the backrest on a flat protected surface.

Position the seat **2** on the backrest **1** as shown and fix using bolts **A** & **B**, spring washers **C** and washers **D**.



Important:

Fasten bolts using allen key **E** but do not fully tighten at this stage.

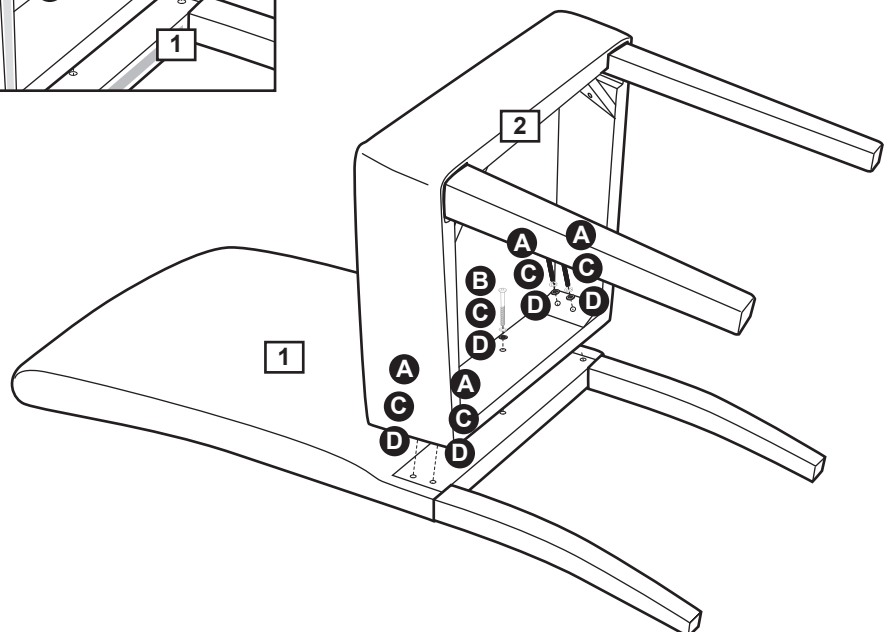
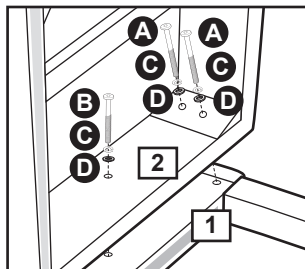

Assembly Instructions

Step 3

Aligning & securing the legs

Carefully turn the chair upright and place on a flat surface.

a: Tighten all bolts using allen key **E**.

Note: This step is essential to prevent the chair from wobbling due to uneven legs.

b: Carefully sit on the chair and make adjustments to ensure the legs are flat even on the floor.

c: After the sitting test, re-tighten bolts again if any adjustment is needed.

Note: It is highly recommended to re-tighten all bolts after using the chair for 7 days.

Note: Keep allen key to re-tighten bolts when required.

Assembly is complete.

a:

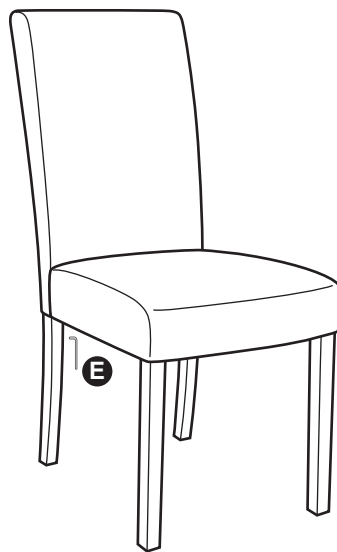

b:

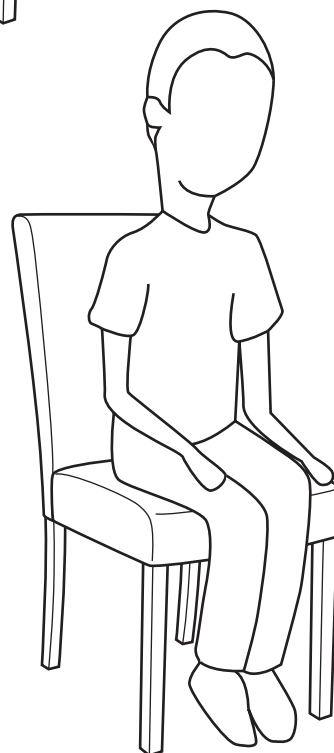

c:

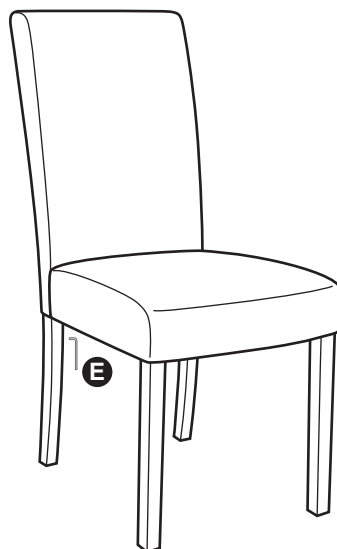

If you need help or have damaged or missing parts, call the **Customer Helpline: 08456 400800**

Aston Chair

Assembly Instructions - Please keep for future reference

603/5213

603/5189

603/5196

603/5237

603/5172

603/5206

603/5220

603/3796

603/3806

257/9814

246/4273

278/9192

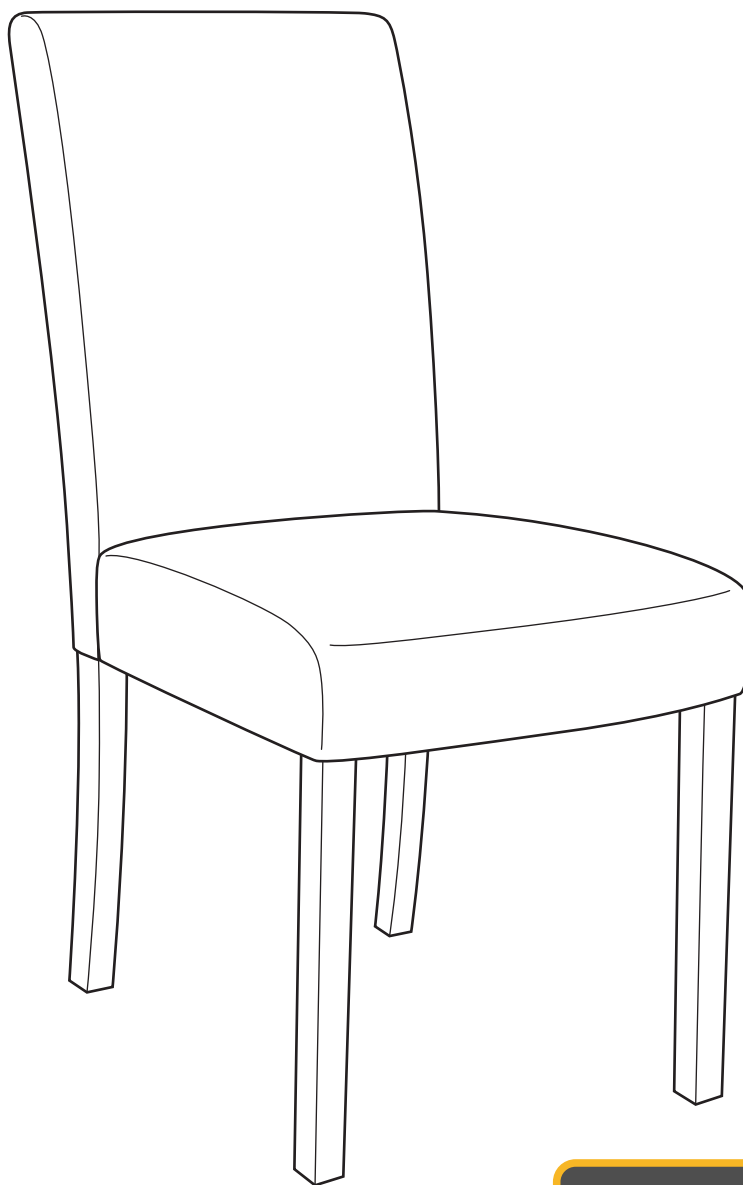

Dimensions

Width - 43.5cm

Depth - 54cm

Height - 86.5cm



Stabilyne seat:
Patented, Recyclable & just plain **TOUGH!**

Important - Please read these instructions fully before starting assembly

If you need help or have damaged or missing parts, call the **Customer Helpline:**
Argos = 0345 640 0800



Safety and Care Advice

Important - Please read these instructions fully before starting assembly

- Check you have all the components and tools listed on the following pages.
- Remove all fittings from the plastic bags and separate them into their groups.
- Keep children and animals away from the work area, small parts could choke if swallowed.
- Make sure you have enough space to layout the parts before starting.
- Parts of the assembly will be easier with 2 people.

- During assembly do not stand or put weight on the product, this could cause damage.
- Assemble the item as close to its final position (in the same room) as possible.
- Assemble on a soft level surface to avoid damaging the unit or your floor.
- Do not stand on the chair.
- Do not use this chair as step ladder.

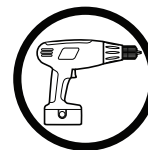

- To reduce the likelihood of damaging your product please ensure that your power drill is set on a low torque setting.
- Unit weight: 4.58 kgs.
- Maximum safe weight of user: 110kgs.

Care and maintenance

- Only clean using a damp cloth and mild detergent, do not use bleach or abrasive cleaners.
- From time to time check that there are no loose screws on this unit.
- This product should not be discarded with household waste. Take to your local authority waste disposal centre.

Handy Hints

- Assemble all parts and bolts loosely during assembly, only once the product is complete should you fully tighten the bolts.
- Regularly check and ensure that all bolts and fittings are tightened properly.

Components - Parts

If you have damaged or missing components, call the
Customer Helpline: Argos = 0345 640 0800

Please check you have all the parts listed below

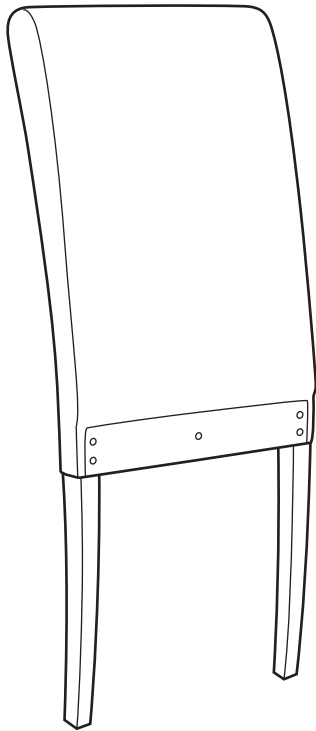

1 Backrest
(36 x 9 x 86.5cm)

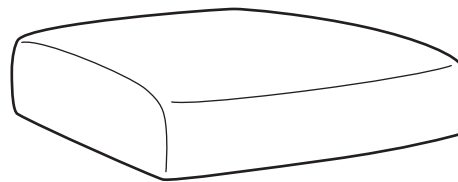

2 Seat
(43.5 x 41.5 x 10cm)







3 Leg x 2
(3 x 3 x 43cm)

Components - Fittings

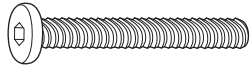
Please check you have all the fittings listed below

Note: The quantities below are the correct amount to complete the assembly. In some cases more fittings may be supplied than are required.

<p>A </p> <p>M6 x 50mm Bolt x 9</p>	<p>B </p> <p>Spring washer x 9</p>	<p>C </p> <p>Flat washer x 9</p>
<p>D </p> <p>Allen key x 1</p>		

Assembly Instructions

Step 1

Attaching legs

Place the seat **2** upside down on a flat protected surface.

Insert the legs **3** into the holes of the seat as shown and fix using bolts **A**, spring washers **B** and washers **C**.



Important:

Fasten bolts using allen key **D** but do not fully tighten at this stage.

Note:

Use oval head of allen key when tightening bolts on corner positions.

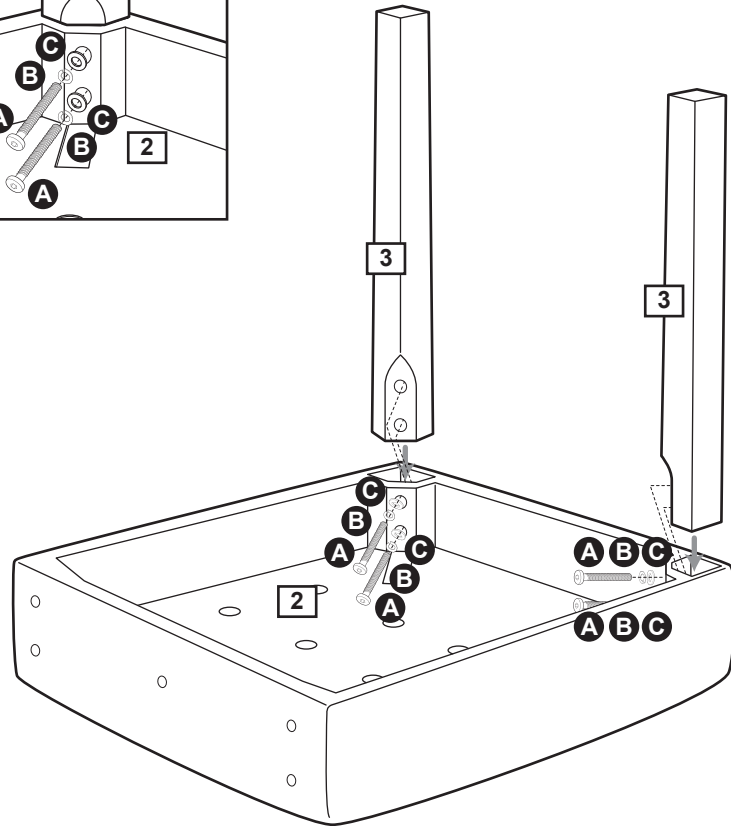
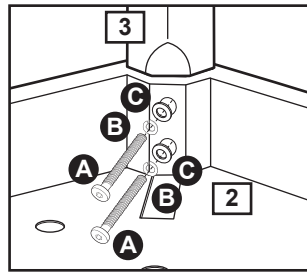

Step 2

Attaching backrest

Place the backrest on a flat protected surface.

Position the seat **2** on the backrest **1** as shown and fix using bolts **A**, spring washers **B** and washers **C**.



Important:

Fasten bolts using allen key **D** but do not fully tighten at this stage.

Note:

Use oval head of allen key when tightening bolts on corner positions.

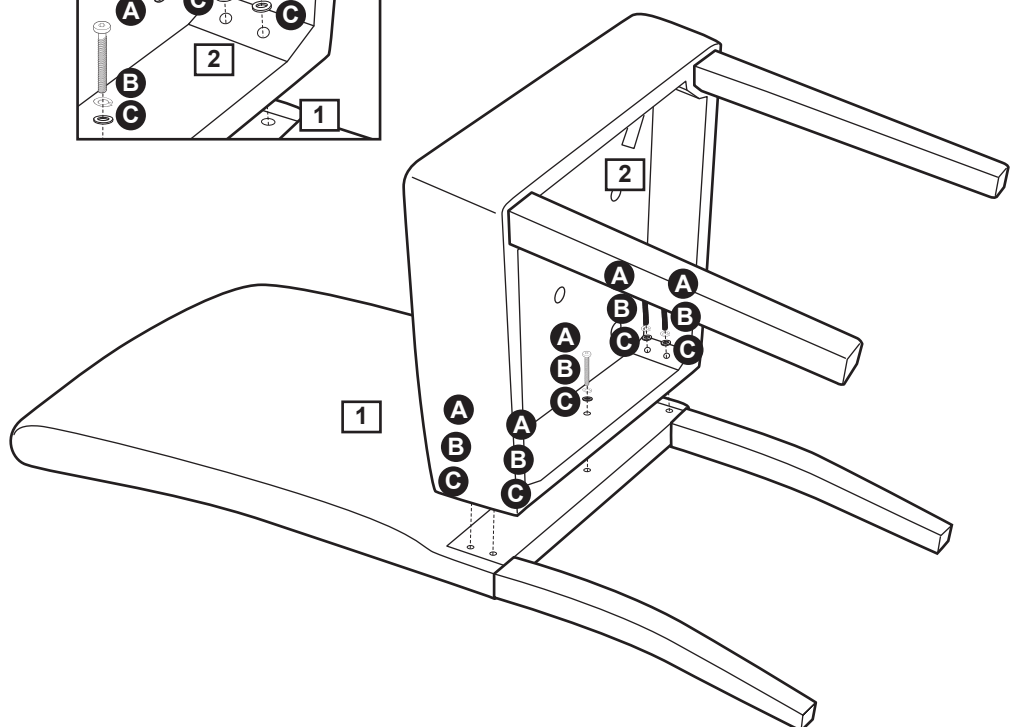
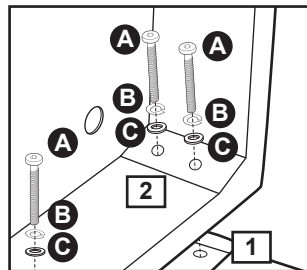

Assembly Instructions

Step 3

Aligning & securing the legs

Carefully turn the chair upright and place on a flat surface.

a: Tighten all bolts using allen key **D**.

Note:

Use oval head of allen key when tightening bolts on corner positions.

Note: This step is essential to prevent the chair from wobbling due to uneven legs.

b: Carefully sit on the chair and make adjustments to ensure the legs are flat even on the floor.

c: After the sitting test, re-tighten bolts again if any adjustment is needed.

Note: It is highly recommended to re-tighten all bolts after using the chair for 7 days.

Note: Keep allen key to re-tighten bolts when required.

Assembly is complete.

a:

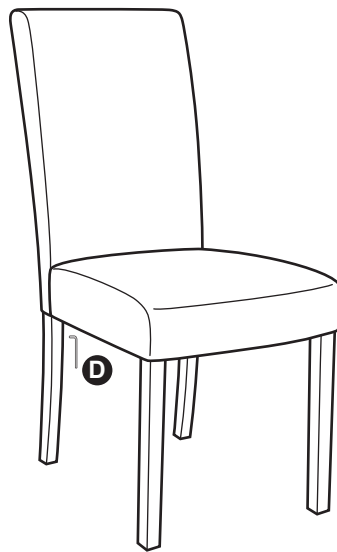

b:

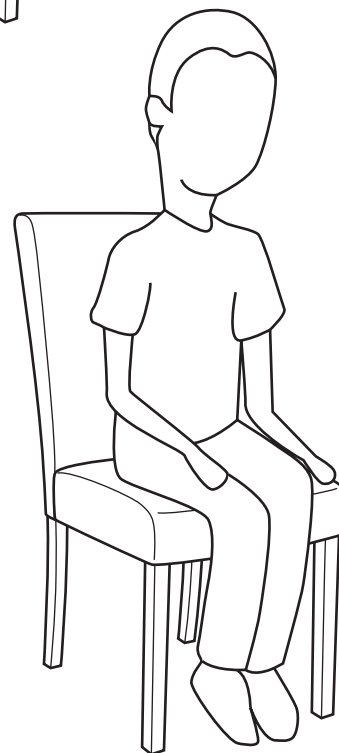

c:

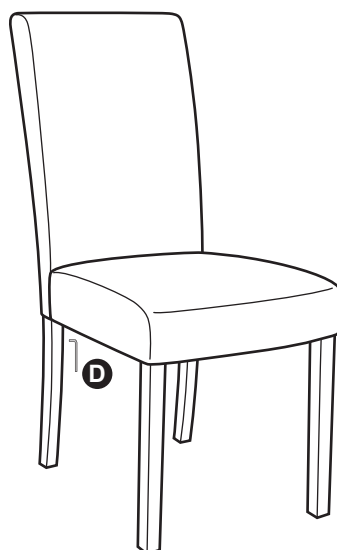

If you need help or have damaged or missing parts, call the **Customer Helpline:**
Argos = 0345 640 0800

Aston Chair

Assembly Instructions - Please keep for future reference

603/5213

603/5189

603/5196

603/5237

603/5172

603/5206

603/5220

603/3796

603/3806

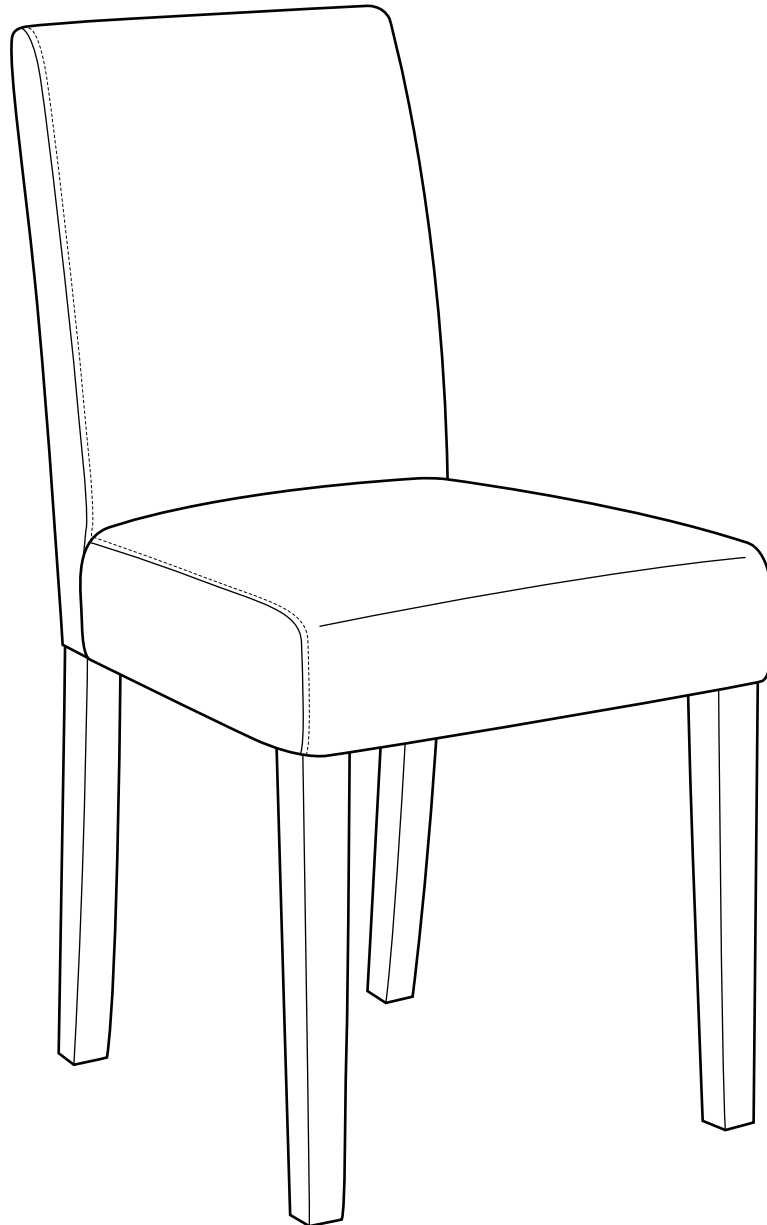

Dimensions

Width - 43cm

Depth - 52cm

Height - 85.5cm

Important - Please read these instructions fully before starting assembly

If you need help or have damaged or missing parts, call the **Customer Helpline: 08456 400800**



Safety and Care Advice

Important - Please read these instructions fully before starting assembly

- We suggest you spend a short time reading through this leaflet and follow the simple step by step assembly instructions.
- Do not discard any of the packaging until you have checked that you have all the parts and the pack of fittings.
- Assemble this product on a flat surface.

- Assemble all parts loosely before tightening any bolts.
- Discard all extra fittings and keep fittings out of reach of children.
- Unit weight: 5kgs.
- Retain Assembly Instructions for future reference.



- We do not recommend the use of power drill/drivers **for inserting screws**, as this could damage the unit. Only use hand screwdrivers.
- Dispose of all packaging carefully and responsibly.

Warnings

- This product should only be used on firm, level ground.
- Make sure the legs remain in contact with the ground.
- Do not stand on the product.

Care and maintenance

- Please clean the table surface using either damp (not wet) cloth and a mild domestic soap solution or by using an appropriate polish.
- Do not use any abrasive materials when cleaning.
- From time to time check that there are no loose bolts on this unit.

Components - Parts

If you have damaged or missing components, call the **Customer Helpline: 08456 400800**

Please check you have all the parts listed below

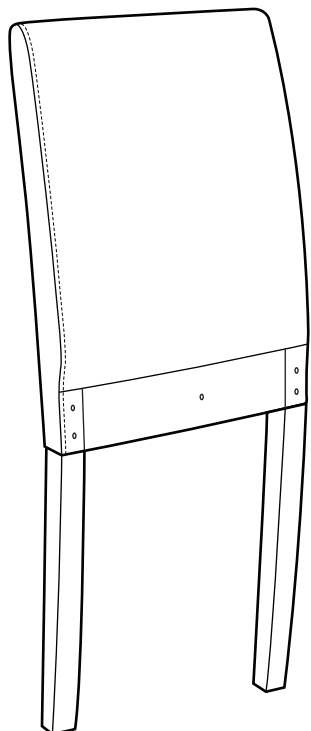

1 Backrest
(34.5 x 85.5 x 10cm)

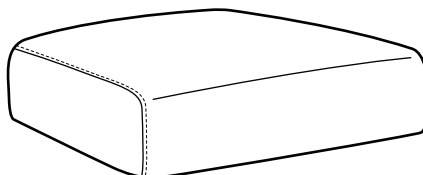

2 Seat
(43 x 41.5 x 11.5cm)





3 Front leg x 2
(43 x 4 x 3.2cm)

Components - Fittings

Please check you have all the fittings listed below

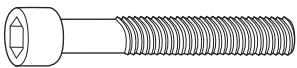
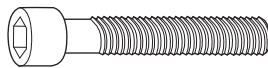
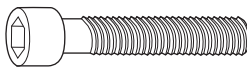
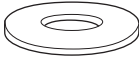
Note: The quantities below are the correct amount to complete the assembly. In some cases more fittings may be supplied than are required.

<p>A </p> <p>M8 x 80mm Bolt x 4</p>	<p>B </p> <p>M8 x 60mm Bolt x 4</p>	<p>C </p> <p>M8 x 50mm Bolt x 1</p>
<p>D </p> <p>Washer x 9</p>	<p>E </p> <p>Allen key x 1</p>	

Ruler - Use this ruler to help correctly identify the screws

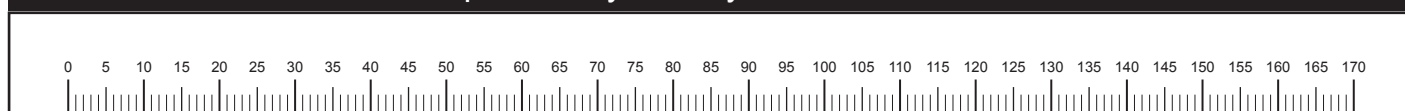

Assembly Instructions

Step 1

Attaching legs

Place the seat **2** upside down on a flat protected surface.

Peel off bottom cloth cover of seat to be able to secure the legs. Pull the cloth from the back side of the seat.

Insert the legs **3** into the holes of the seat as shown and fix using bolts **B** and washers **D**.



Important:
Do not fully tighten bolts at this stage.

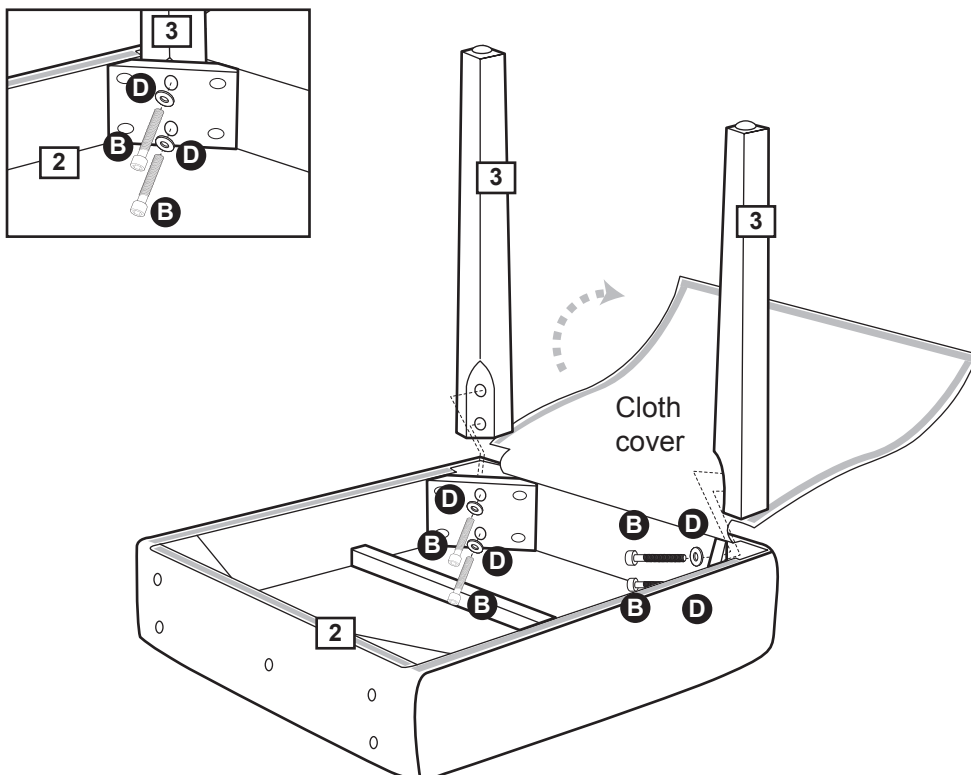

Step 2

Attaching backrest

Place the backrest on a flat protected surface.

Position the seat **2** on the backrest **1** as shown and fix using bolts **A** & **C** and washers **D**. Tighten the bolts using allen key **E**.

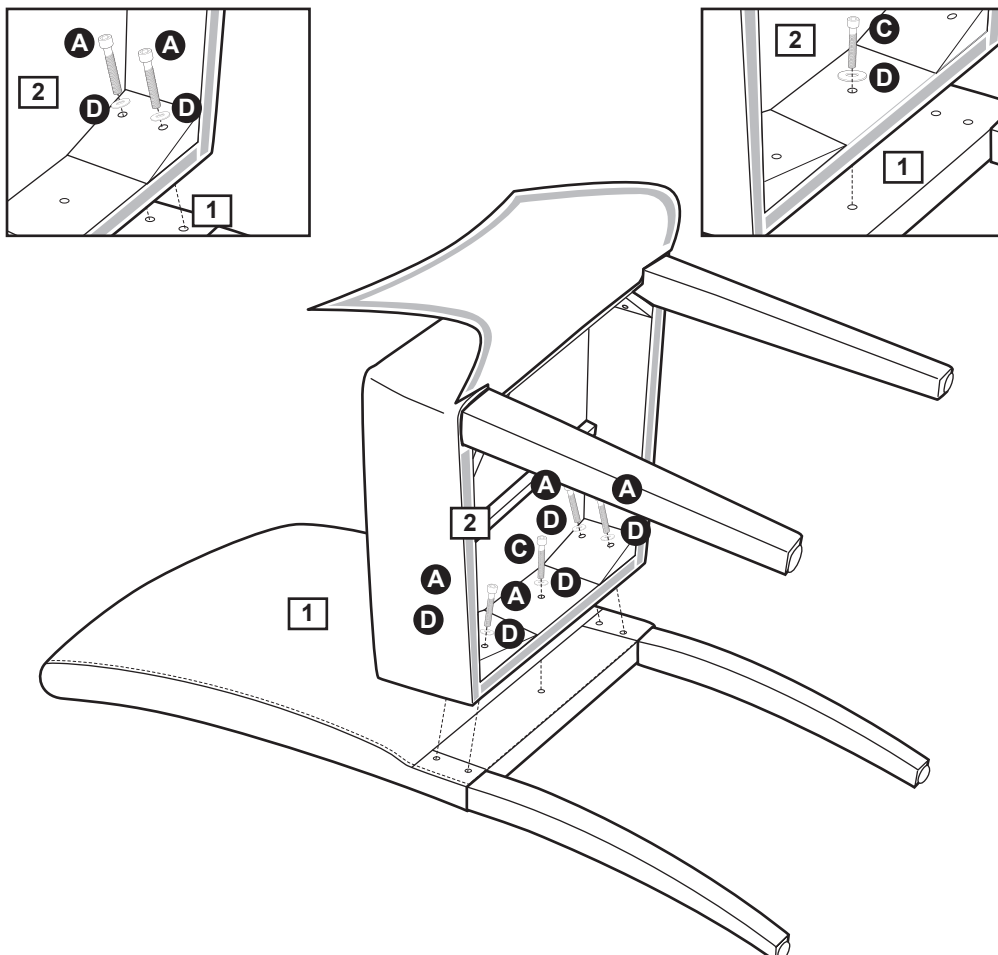

Assembly Instructions

Step 3

Aligning the legs

Carefully turn over the chair and place on a flat surface.

Tighten all the bolts on the legs using allen key while making adjustments to ensure the legs are even on the floor.

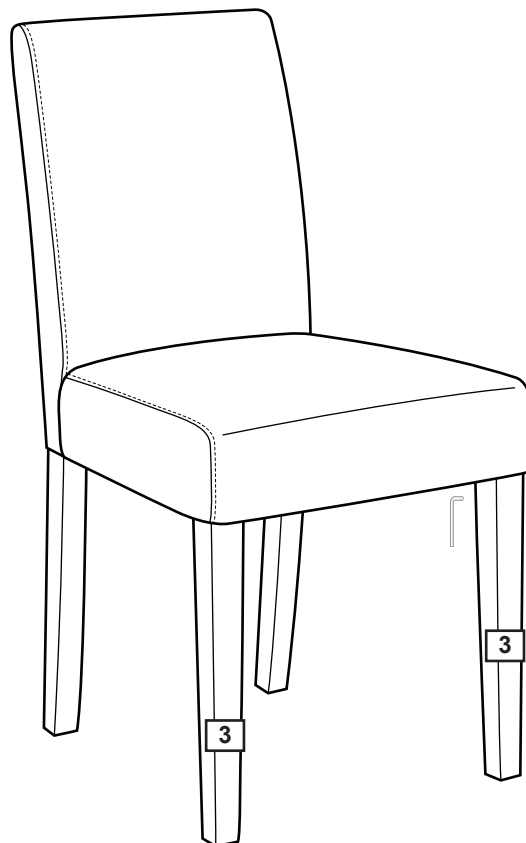

Step 4

Re-attaching the bottom cloth cover

Re-attach the bottom cloth cover as shown and fasten with the magic tape.

Carefully turn over the chair.

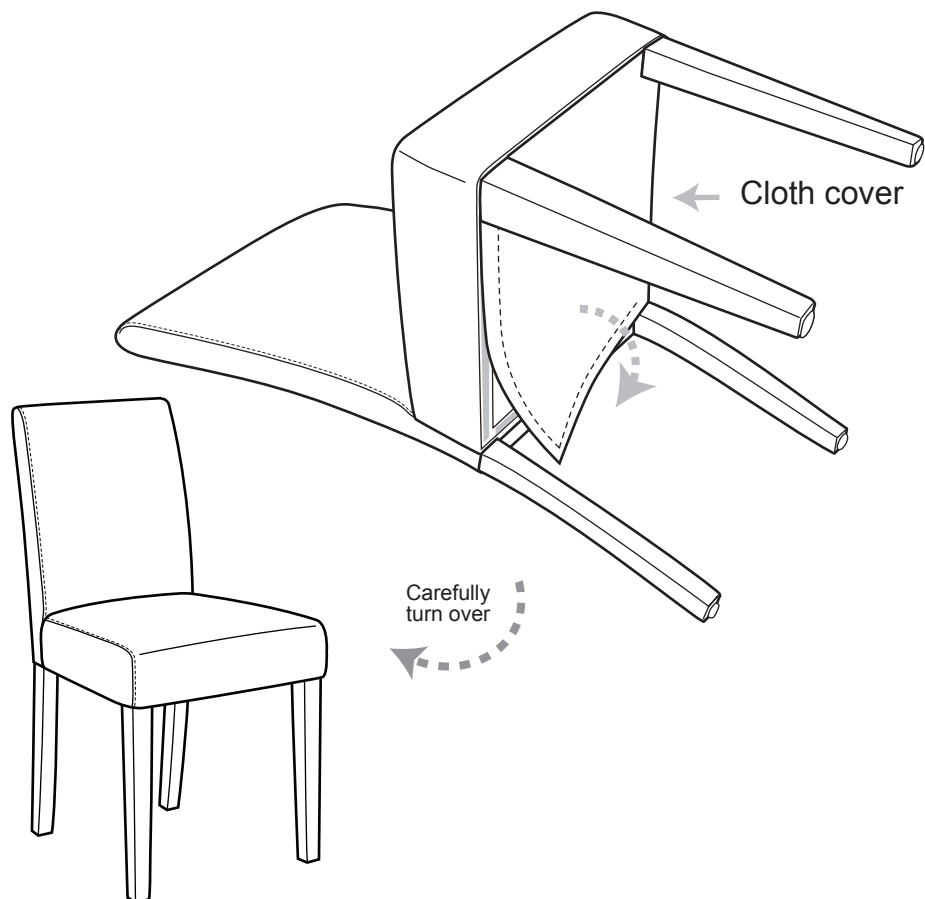

Assembly is complete.

If you need help or have damaged or missing parts, call the **Customer Helpline: 08456 400800**