

# Oslo Oak Table

Assembly Instructions - Please keep for future reference

603/3071

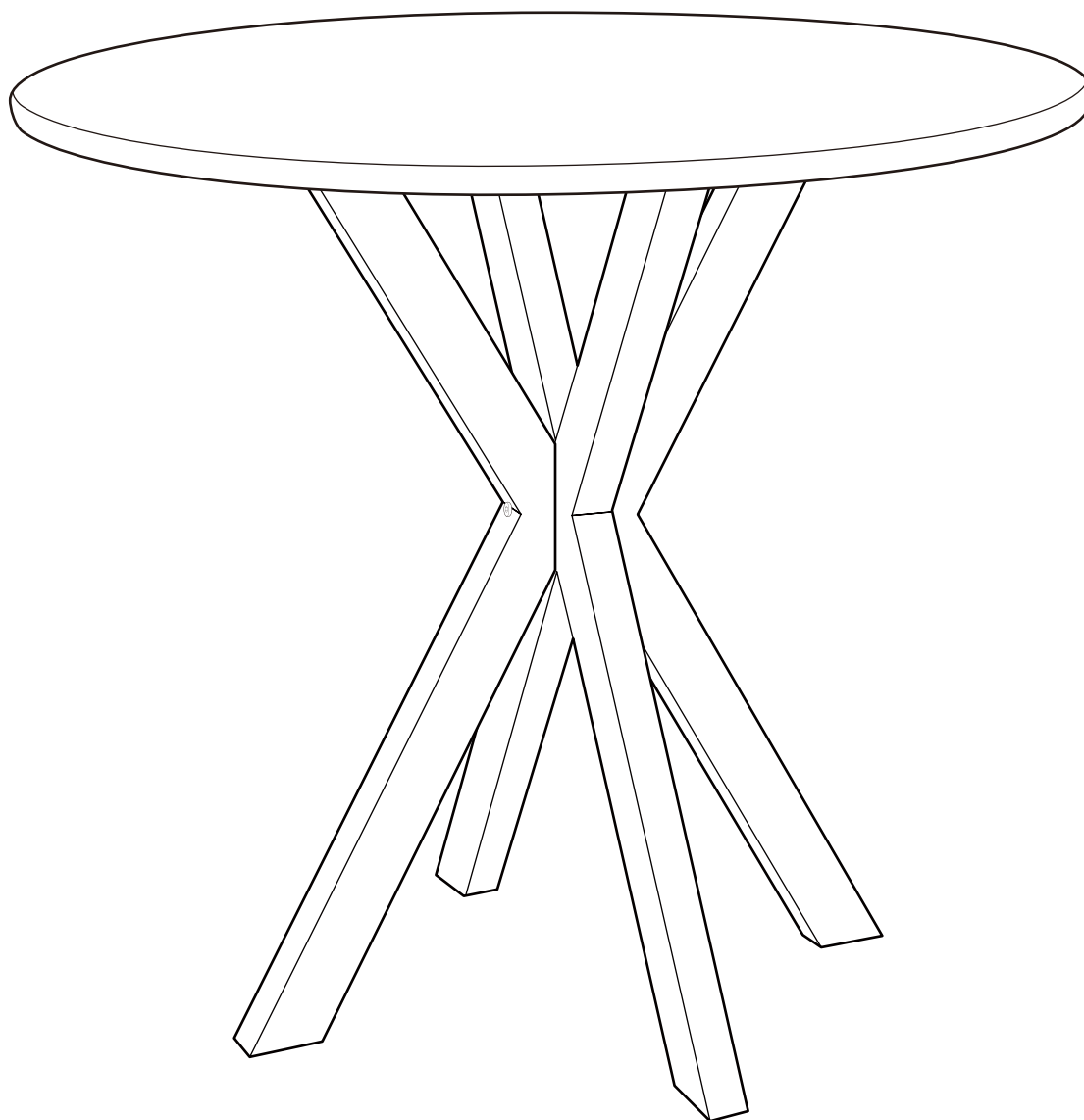

## Dimensions

Width - 100cm  
Depth - 100cm  
Height - 75cm

**Important - Please read these instructions fully before starting assembly**

If you need help or have damaged or missing parts, call the **Customer Helpline: 08456 400800**



# Safety and Care Advice

## Important - Please read these instructions fully before starting assembly

- We suggest you spend a short time reading through this leaflet and follow the simple step by step assembly instructions.
- Do not discard any of the packaging until you have checked that you have all the parts and the pack of fittings.
- Assemble this product on a flat surface.

- Assemble all parts loosely before tightening any bolts.
- Discard all extra fittings and keep fittings out of reach of children.
- Unit weight: 21kgs.
- At least 2 people are required to assemble this product.
- Retain Assembly Instructions for future reference.



- We do not recommend the use of power drill/drivers **for inserting screws**, as this could damage the unit. Only use hand screwdrivers.
- Dispose of all packaging carefully and responsibly.

## Warnings

- This product should only be used on firm, level ground.
- Make sure the legs remain in contact with the ground.
- Do not stand on the product.

## Care and maintenance

- Please clean the table surface using either damp (not wet) cloth and a mild domestic soap solution or by using an appropriate polish.
- Do not use any abrasive materials when cleaning.
- From time to time check that there are no loose bolts on this unit.

# Components - Parts

If you have damaged or missing components, call the **Customer Helpline: 08456 400800**

Please check you have all the parts listed below



**1** Table Top  
(100 x 100 x 2cm)



**2** Mounting board  
(48 x 48 x 1.5cm)

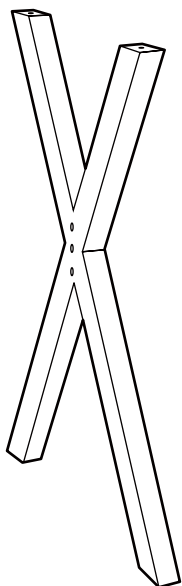

**3** Big leg  
(80 x 71.5 x 6cm)

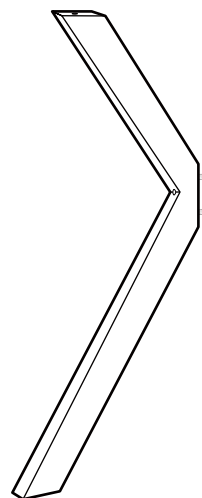





**4** Small leg x 2  
(40 x 71.5 x 6cm)

# Components - Fittings

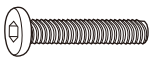
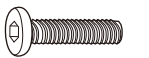
Please check you have all the fittings listed below

**Note:** The quantities below are the correct amount to complete the assembly. In some cases more fittings may be supplied than are required.

<p><b>A</b> </p> <p>M6 x 60mm Bolt x 2</p>	<p><b>B</b> </p> <p>M6 x 30mm Bolt x 8</p>	<p><b>C</b> </p> <p>Spring Washer x 4</p>
<p><b>D</b> </p> <p>Washer x 4</p>	<p><b>E</b> </p> <p>Allen Key x 1</p>	

**Ruler** - Use this ruler to help correctly identify the screws



# Assembly Instructions

## Step 1

### Attaching legs

Attach the small legs **4** to the big leg **3** by inserting the wooden dowels into holes as shown. Then secure using bolts **A**. Tighten bolts using allen key **E**.

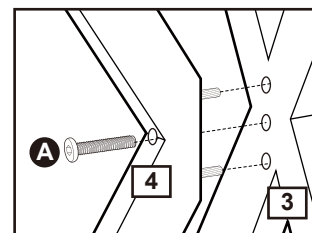
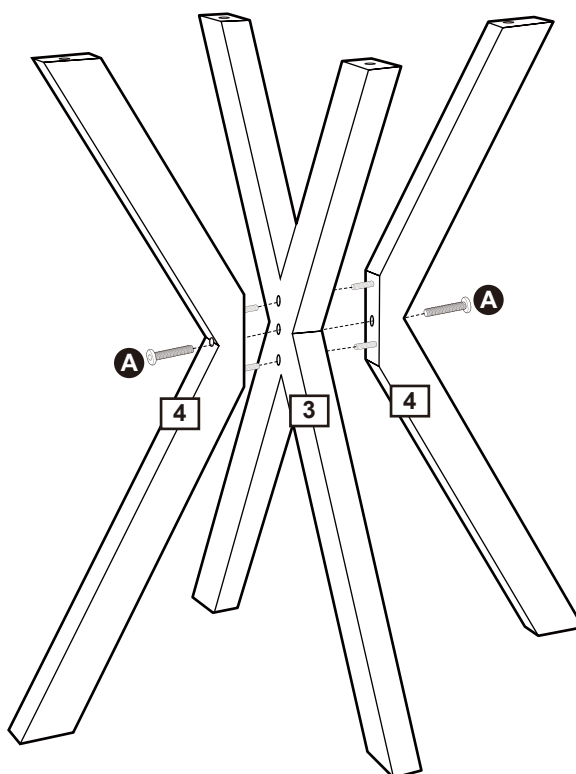

## Step 2

### Attaching mounting board

Attach the mounting board **2** onto legs and ensure that the surface with the label "TOP" is facing up as shown. Then fix using bolts **B**. Tighten bolts using allen key **E**.

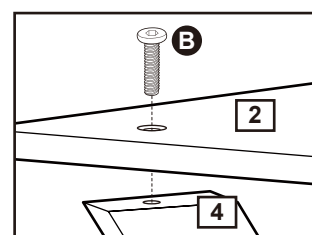
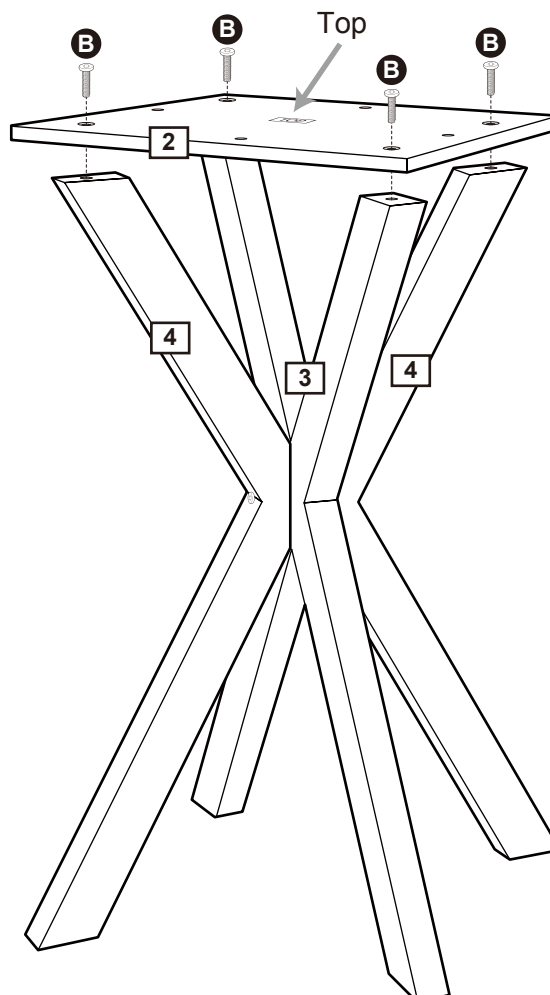

# Assembly Instructions

## Step 3

### Attaching table top

Attach the table top **1** onto the mounting board **2** as shown and secure using bolts **B** washer **D** and spring washer **C**. Tighten bolts using allen key **E**.

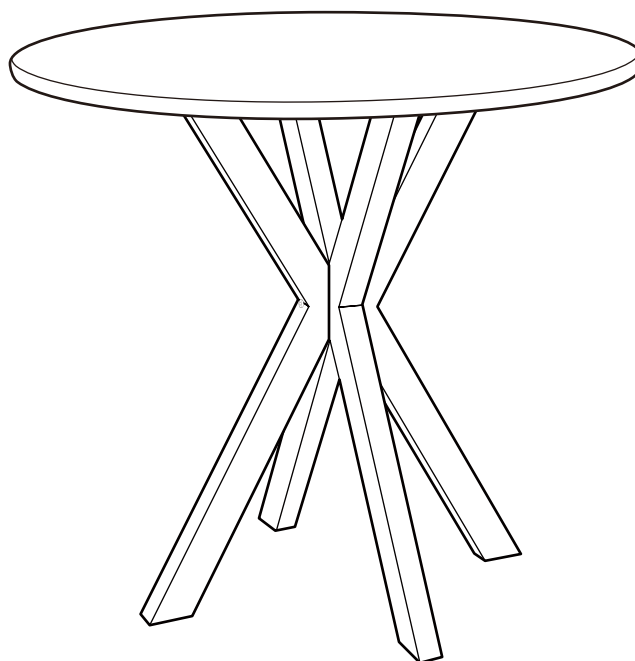
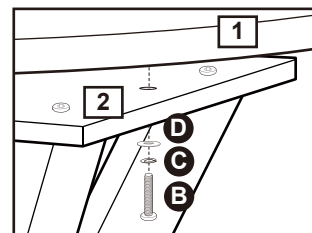
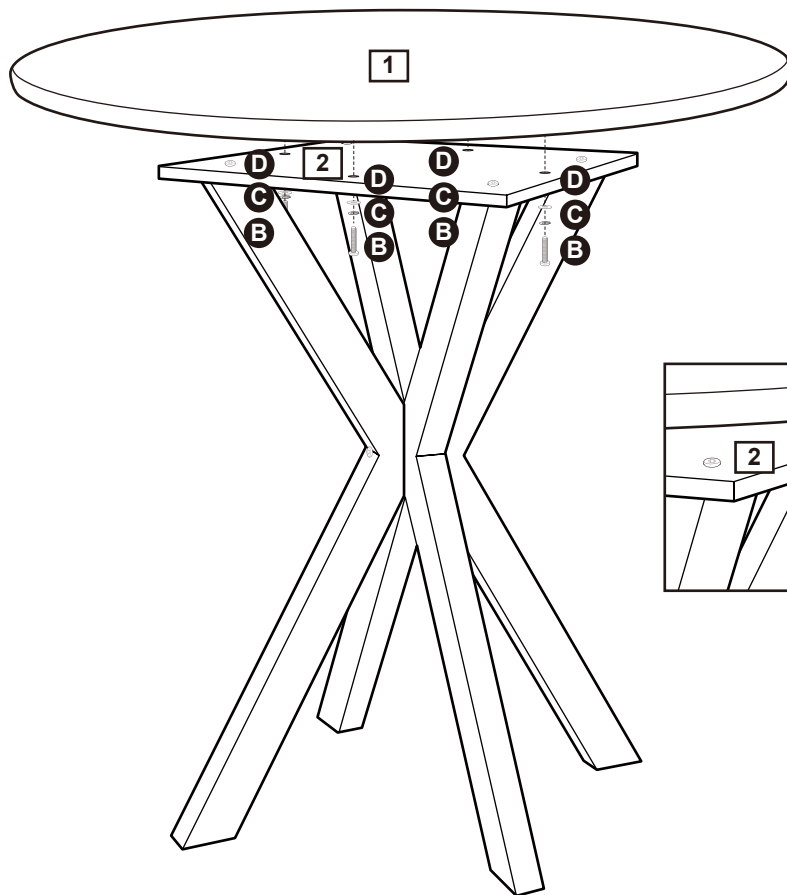

**Assembly is complete.**

If you need help or have damaged or missing parts, call the **Customer Helpline: 08456 400800**

# Oslo Oak Table

Assembly Instructions - Please keep for future reference

603/3071

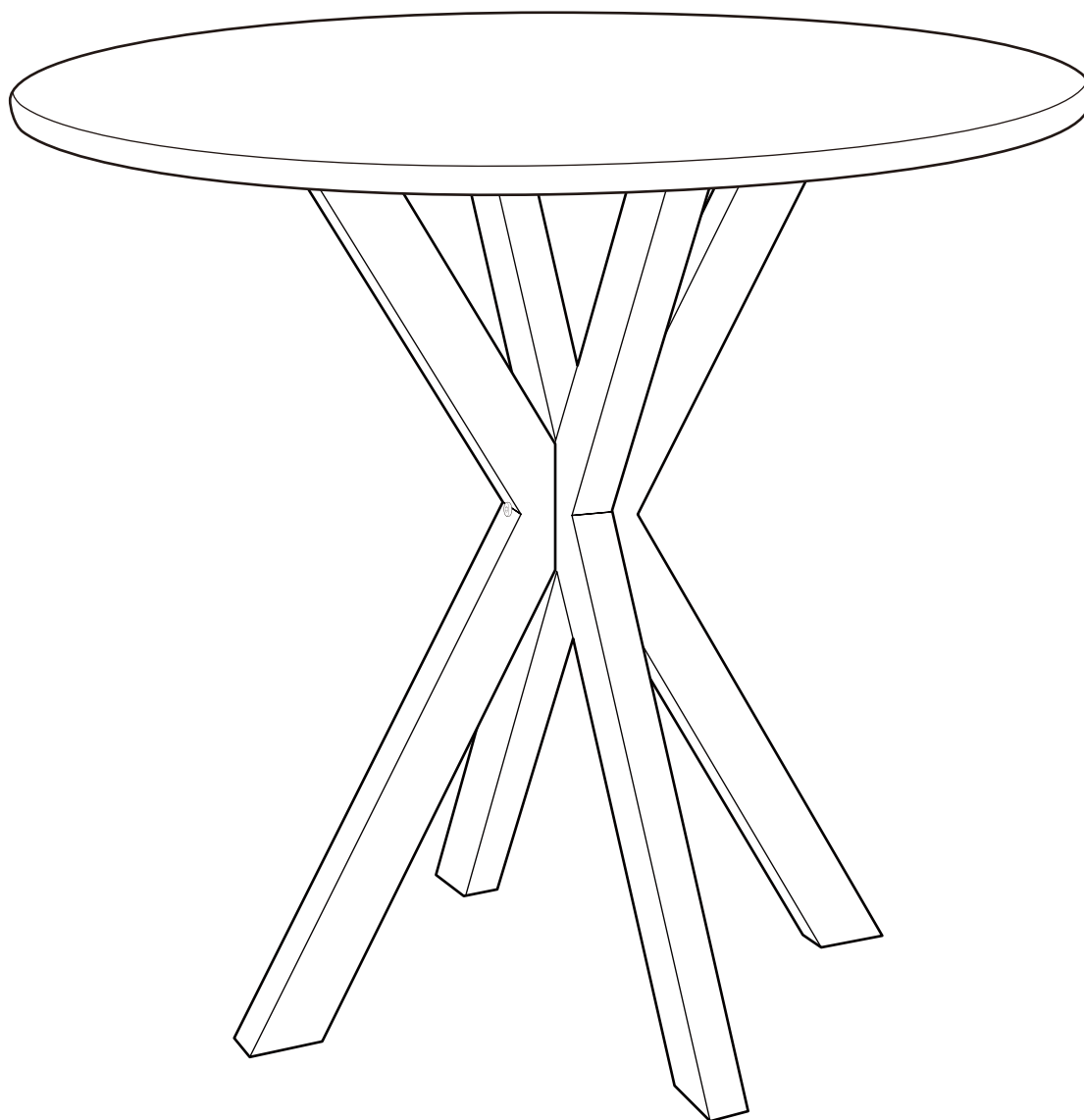

## Dimensions

Width - 100cm

Depth - 100cm

Height - 75cm

**Important - Please read these instructions fully before starting assembly**

If you need help or have damaged or missing parts, call the **Customer Helpline: 08456 400800**



# Safety and Care Advice

## Important - Please read these instructions fully before starting assembly

- We suggest you spend a short time reading through this leaflet and follow the simple step by step assembly instructions.
- Do not discard any of the packaging until you have checked that you have all the parts and the pack of fittings.
- Assemble this product on a flat surface.

- Assemble all parts loosely before tightening any bolts.
- Discard all extra fittings and keep fittings out of reach of children.
- Unit weight: 21kgs.
- At least 2 people are required to assemble this product.
- Retain Assembly Instructions for future reference.



- We do not recommend the use of power drill/drivers **for inserting screws**, as this could damage the unit. Only use hand screwdrivers.
- Dispose of all packaging carefully and responsibly.

## Warnings

- This product should only be used on firm, level ground.
- Make sure the legs remain in contact with the ground.
- Do not stand on the product.

## Care and maintenance

- Please clean the table surface using either damp (not wet) cloth and a mild domestic soap solution or by using an appropriate polish.
- Do not use any abrasive materials when cleaning.
- From time to time check that there are no loose bolts on this unit.

# Components - Parts

If you have damaged or missing components, call the **Customer Helpline: 08456 400800**

Please check you have all the parts listed below



**1** Table Top  
(100 x 100 x 2cm)



**2** Mounting board  
(48 x 48 x 1.5cm)

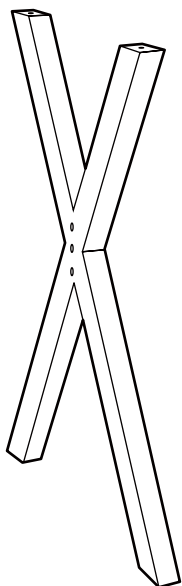

**3** Big leg  
(80 x 71.5 x 6cm)

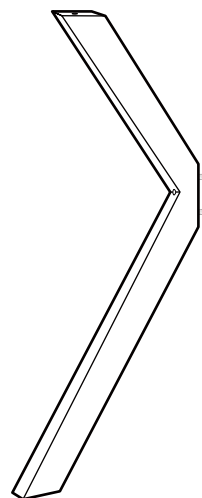





**4** Small leg x 2  
(40 x 71.5 x 6cm)

# Components - Fittings

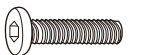
Please check you have all the fittings listed below

**Note:** The quantities below are the correct amount to complete the assembly. In some cases more fittings may be supplied than are required.

<p><b>A</b> </p> <p>M6 x 60mm Bolt x 2</p>	<p><b>B</b> </p> <p>M6 x 30mm Bolt x 8</p>	<p><b>C</b> </p> <p>Spring Washer x 4</p>
<p><b>D</b> </p> <p>Washer x 4</p>	<p><b>E</b> </p> <p>Allen Key x 1</p>	

**Ruler** - Use this ruler to help correctly identify the screws





# Assembly Instructions

## Step 1

### Attaching legs

Attach the small legs **4** to the big leg **3** by inserting the wooden dowels into holes as shown. Then secure using bolts **A**. Tighten bolts using allen key **E**.

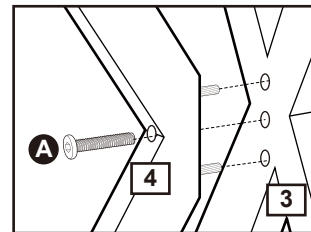
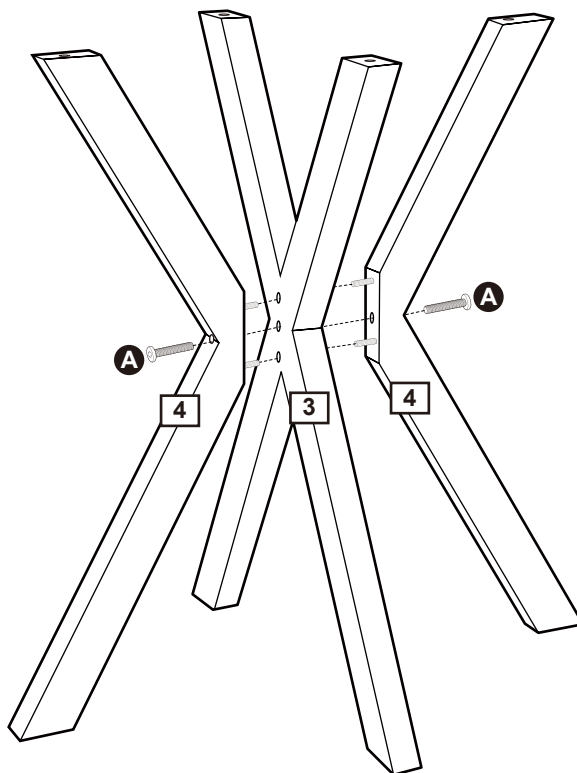

## Step 2

### Attaching mounting board

Attach the mounting board **2** onto legs and ensure that the surface with the label "TOP" is facing up as shown. Then fix using bolts **B**. Tighten bolts using allen key **E**.

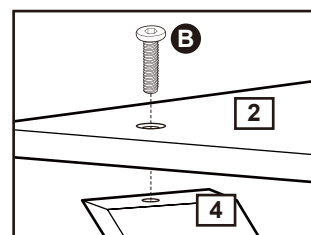
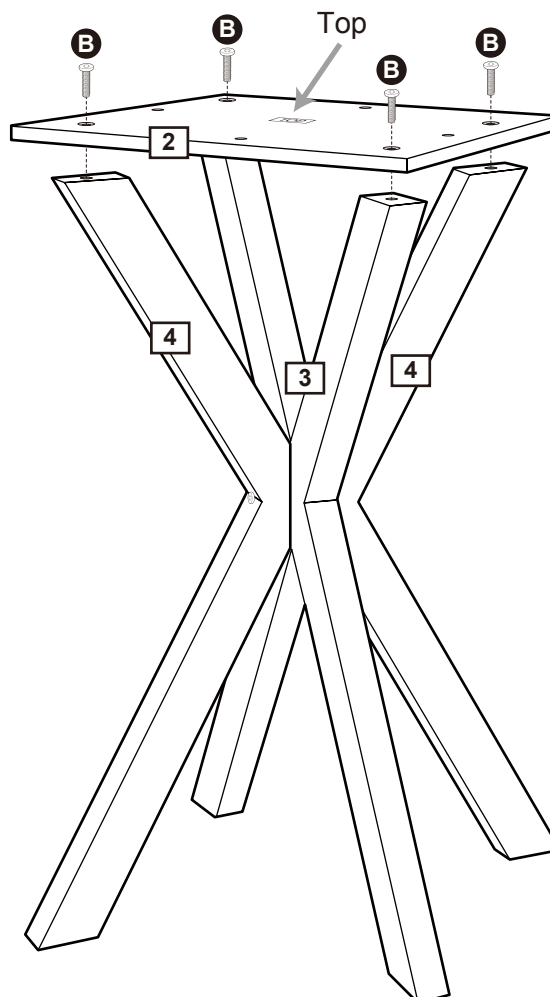

# Assembly Instructions

## Step 3

### Attaching table top

Attach the table top **1** onto the mounting board **2** as shown and secure using bolts **B** washer **D** and spring washer **C**. Tighten bolts using allen key **E**.

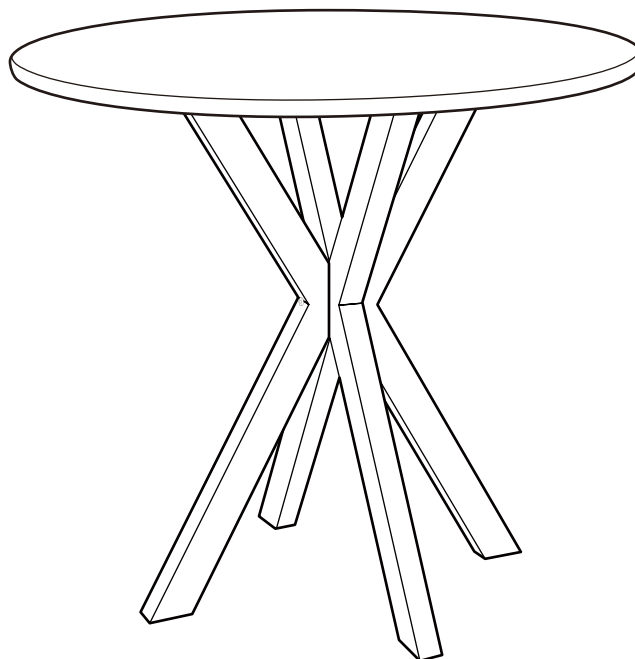
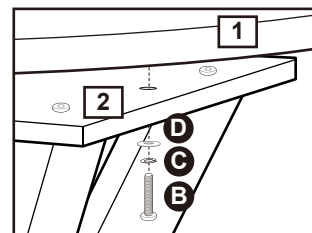
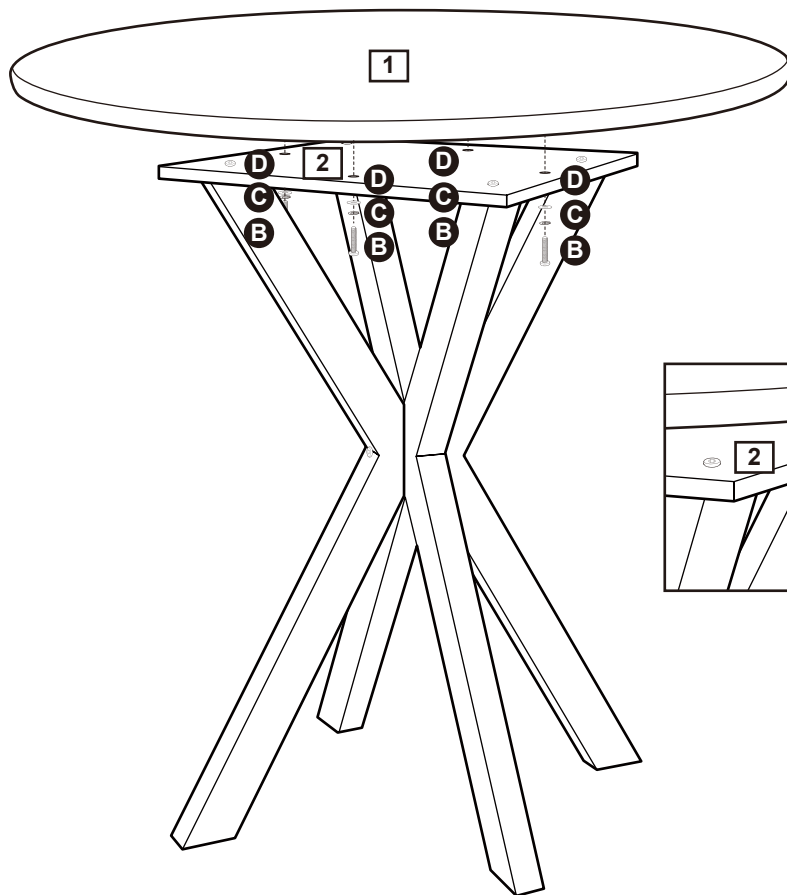

**Assembly is complete.**

If you need help or have damaged or missing parts, call the **Customer Helpline: 08456 400800**