

Cat. No. 6029731 KINGSTON OAKSTAIN PAIR OF CHOC CHAIRS
6029779 KINGSTON OAKSTAIN PAIR OF CREAM CHAIRS
6029803 KINGSTON WALNUTSTAIN PAIR OF CHOC CHAIRS
6029834 KINGSTON WALNUTSTAIN PAIR OF CREAM CHAIRS

Simple Assembly Instruction

Page 1

Please keep for reference

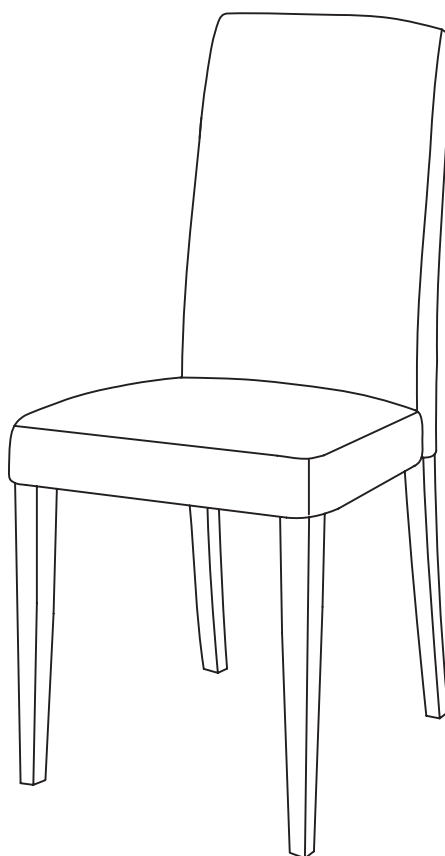

IMPORTANT

- 1. Please read these instructions carefully to familiarise yourself with the assembly procedure.*
- 2. Check that you have all the component parts and fittings listed on the next page.*
- 3. Ensure you have enough space to lay out all the parts before assembly.*
- 4. To avoid scratching it is recommended that you assemble the chair on a soft level surface.*
- 5. The maximum weight of user - 100kgs*

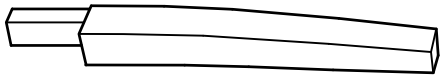

Ⓐ Front Leg x 2

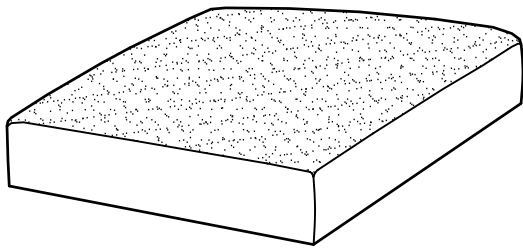

Ⓑ Seat x 1

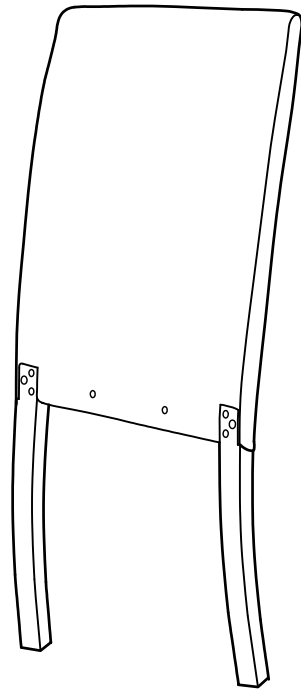

Ⓒ Back Stand x 1

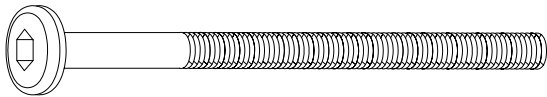

Ⓓ Long JCBC Screw x 4

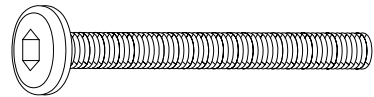

Ⓔ Short JCBC Screw x 6



Ⓕ Spring Washer x 10

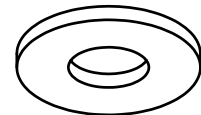

Ⓖ Flat Washer x 10

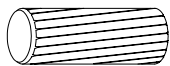

Ⓗ Wooden Dowel x 2

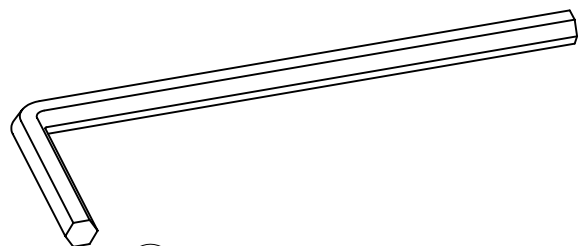

Ⓘ Allen Key x 1

1. Place the chair seat (B) on top of the table. Insert the front legs (A) into the seat as shown in the **fig.1**. Secure the short JCBC screws (E) using spring washers (F) and flat washers (G) as shown in **Fig.1**.

Insert the dowels (H) into the holes of the chair seat as shown in **Fig.1**.

Do not fully tighten all screws at this stage.

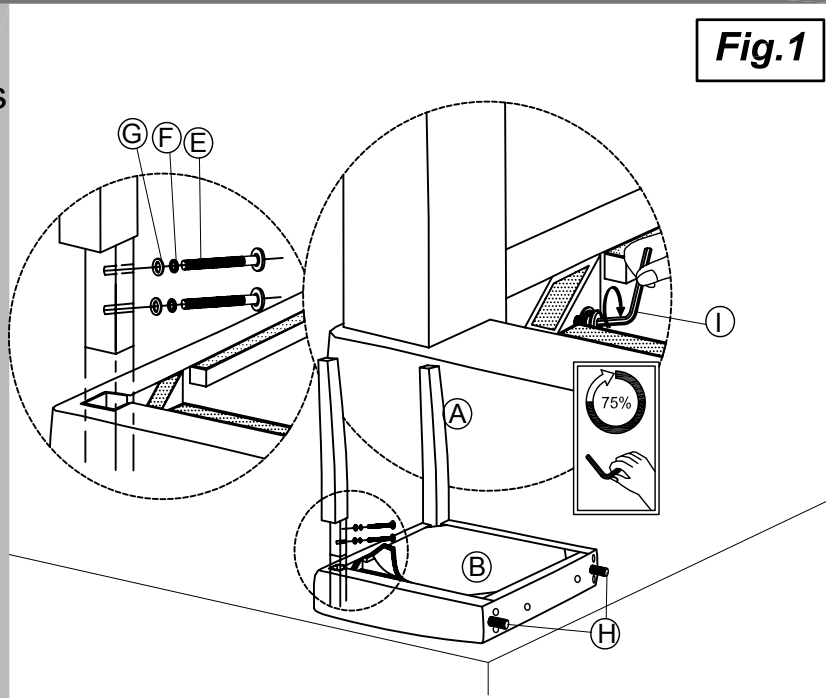

Fig.1

2. Fix the back stand (C) onto the dowels as shown in **Fig.2**. Secure the long JCBC screws (D) using spring washers (F) and flat washers (G) as shown in **Fig.2**.

Secure the short JCBC screws (E) using spring washers (F) and flat washers (G) as show in **Fig.2**.

Do not fully tighten all screws at this stage.

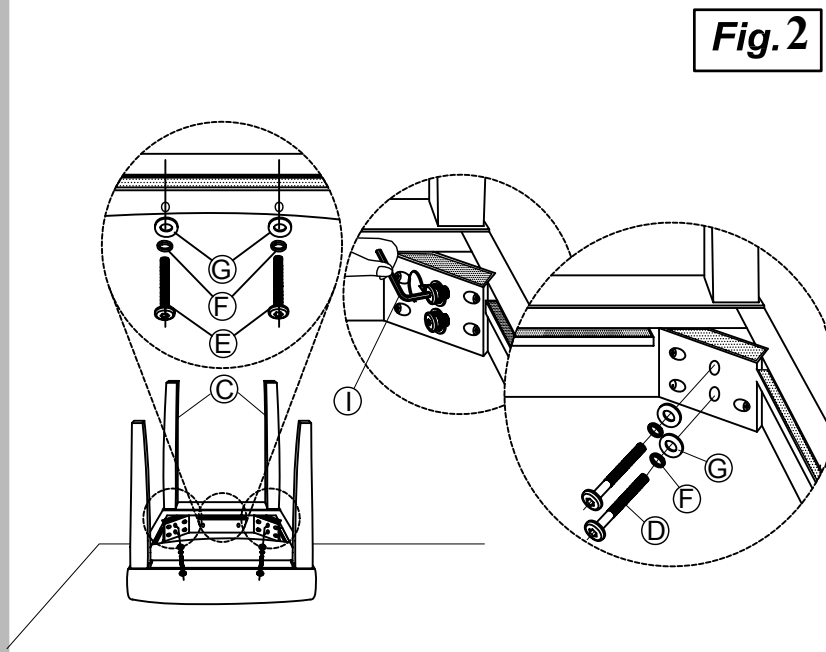

Fig.2

3. Fully tighten all screws using allen key (I).

Finally, zap on the velcro tape at the bottom of the seat.

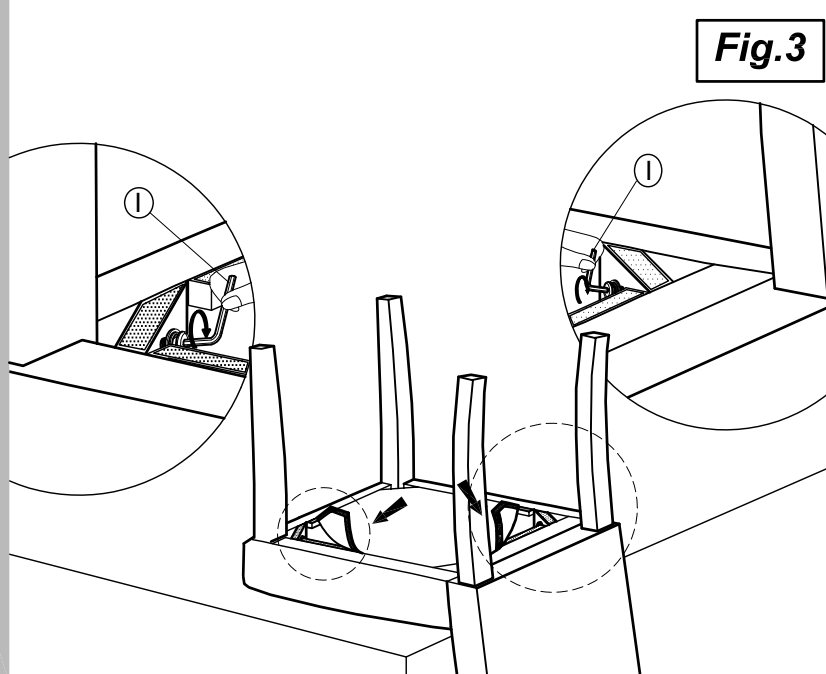

Fig.3

Dining Chair

Assembly Instructions - Please keep for future reference

603/4135

603/2333

603/2900

603/0452

602/9834

603/2364

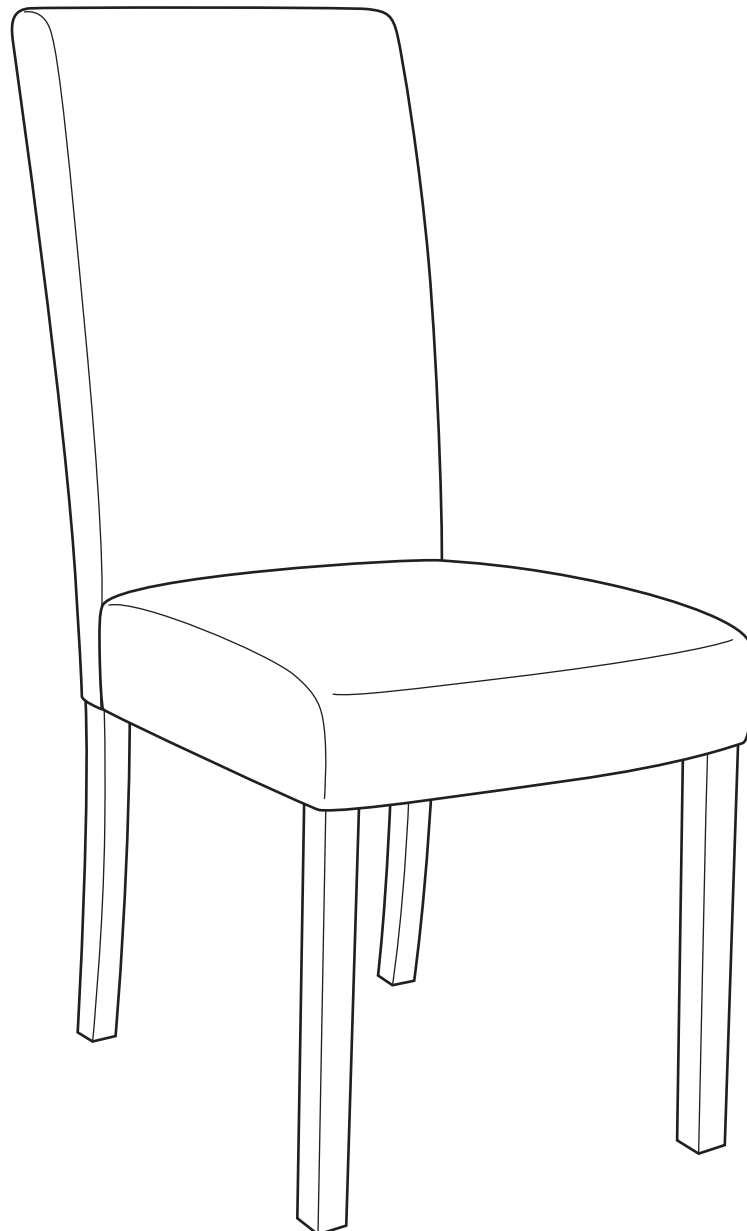

Dimensions

Width - 44cm

Depth - 54cm

Height - 92cm

Important - Please read these instructions fully before starting assembly

If you need help or have damaged or missing parts, call the **Customer Helpline: 08456 400800**



Safety and Care Advice

Important - Please read these instructions fully before starting assembly

- Assemble this product on a flat surface.
- Assemble all parts loosely before tightening any bolts.
- Do not discard any of the packaging until you have checked that you have all the parts and the pack of fittings.

- Discard all extra fittings and keep fittings out of reach of children.
- Unit weight: 4.9kgs.
- Maximum safe weight of user: 110kgs.
- Retain Assembly Instructions for future reference.



- We do not recommend the use of power drill/drivers **for inserting screws**, as this could damage the unit. Only use hand screwdrivers.
- Dispose of all packaging carefully and responsibly.

Warnings

- This product should only be used on firm, level ground.
- Make sure the legs remain in contact with the ground.
- Do not stand on the product.

Care and maintenance

- Please clean the unit surface using either damp (not wet) cloth and a mild domestic soap solution or by using an appropriate polish.
- Do not use any abrasive materials when cleaning.
- From time to time check that there are no loose bolts on this unit.

Components - Parts

If you have damaged or missing components, call the **Customer Helpline: 08456 400800**

Please check you have all the parts listed below

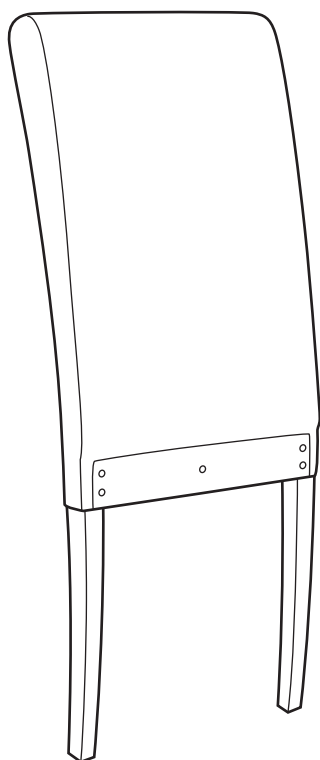

1 Backrest
(36 x 10 x 92cm)

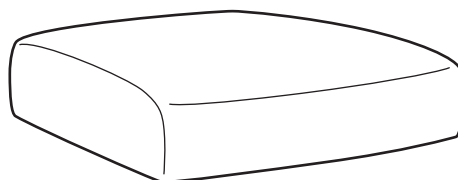

2 Seat
(43.5 x 41 x 9.5cm)

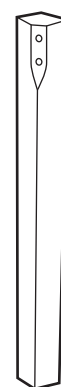





3 Leg x 2
(3 x 3 x 43cm)

Components - Fittings

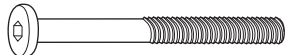
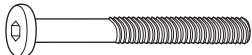
Please check you have all the fittings listed below

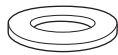
Note: The quantities below are the correct amount to complete the assembly. In some cases more fittings may be supplied than are required.

<p>A </p> <p>M6 x 85mm Bolt x 4</p>	<p>B </p> <p>M6 x 55mm Bolt x 5</p>	<p>C </p> <p>Spring washer x 9</p>
<p>D </p> <p>Washer x 9</p>	<p>E </p> <p>Allen key x 1</p>	

Ruler - Use this ruler to help correctly identify the screws

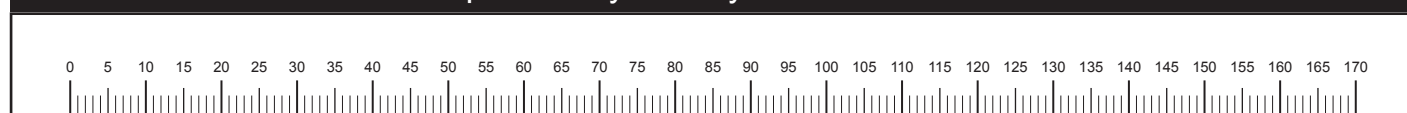

Assembly Instructions

Step 1

Attaching legs

Place the seat **2** upside down on a flat protected surface.

Insert the legs **3** into the holes of the seat as shown and fix using bolts **B**, spring washer **C** and washers **D**. Tighten the bolts using allen key **E**.



Important:

Do not fully tighten bolts at this stage.

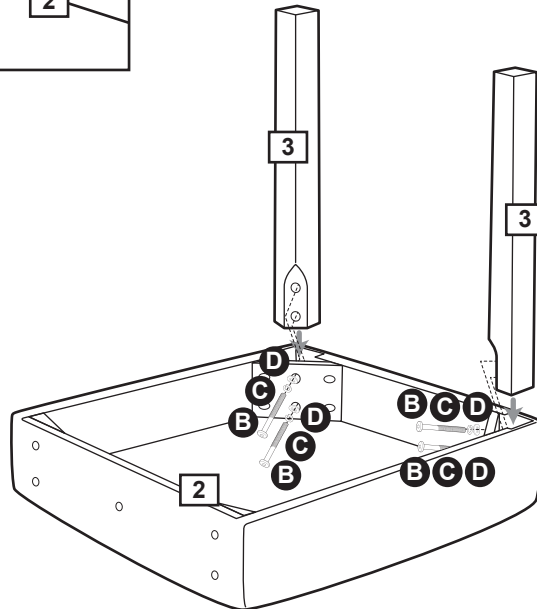
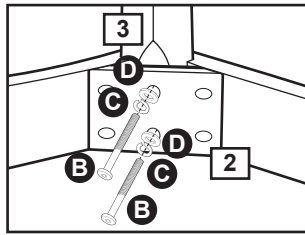

Step 2

Attaching backrest

Place the backrest on a flat protected surface.

Position the seat **2** on the backrest **1** as shown and fix using bolts **A** & **B**, spring washers **C** and washers **D**. Tighten bolts using allen key **E**.



Important:

Do not fully tighten bolts at this stage.

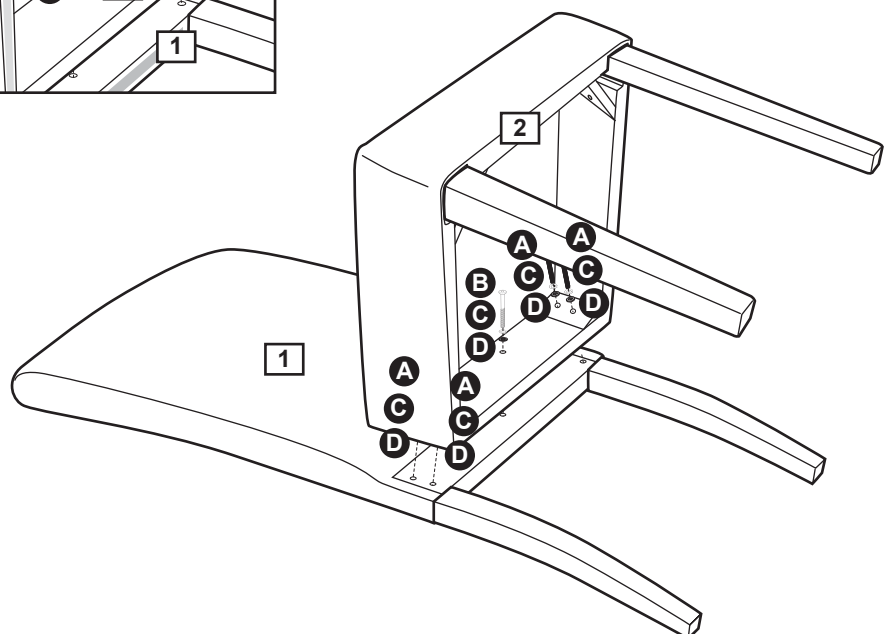
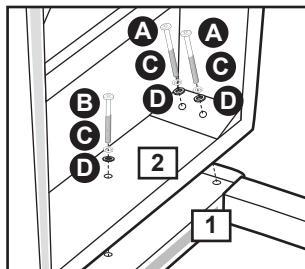

Assembly Instructions

Step 3

Aligning & securing the legs

Carefully turn the chair upright and place on a flat surface.

a: Tighten all bolts using allen key **E**.

Note: This step is essential to prevent the chair from wobbling due to uneven legs.

b: Carefully sit on the chair and make adjustments to ensure the legs are flat even on the floor.

c: After the sitting test, re-tighten bolts again if any adjustment is needed.

Note: It is highly recommended to re-tighten all bolts after using the chair for 7 days.

Note: Keep allen key to re-tighten bolts when required.

Assembly is complete.

a:

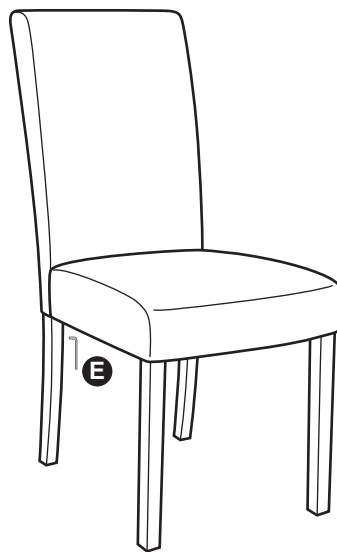

b:

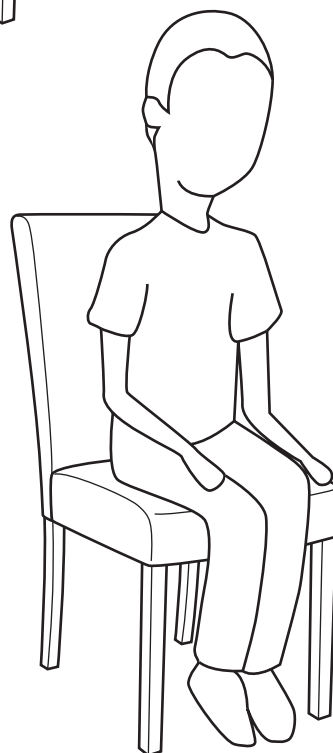

c:

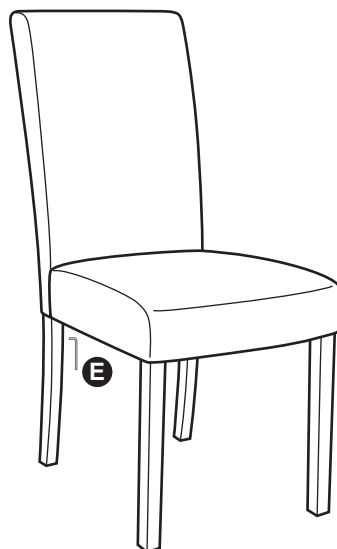

If you need help or have damaged or missing parts, call the **Customer Helpline: 08456 400800**

Please keep for reference



IMPORTANT

- 1. Please read these instructions carefully to familiarise yourself with the assembly procedure.*
- 2. Check that you have all the component parts and fittings listed on the next page.*
- 3. Ensure you have enough space to lay out all the parts before assembly.*
- 4. To avoid scratching it is recommended that you assemble the table on a soft level surface.*

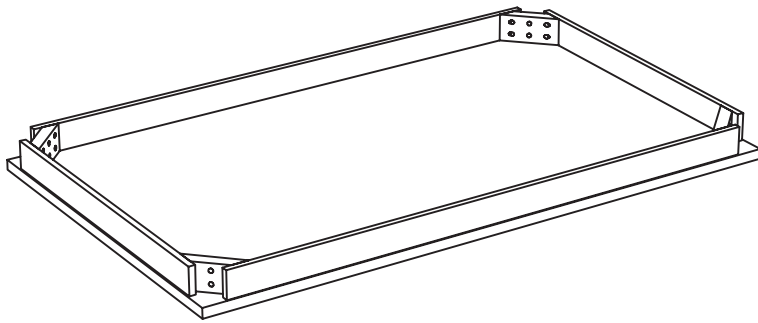

(A) Table top x 1



(B) Table Leg x 4

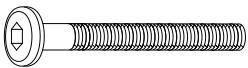

(C) JCBC x 8



(D) Spring Washer x 8

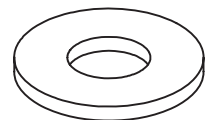

(E) Flat Washer x 8



(F) Alen Key

1. Lay the table top (A) face down on your work surface using scrap packaging to protect the top.
2. Fit leg (B) to one of four corner brackets and secure using the JCBC (C), spring washers (D) and flat washers (E). Tighten with alen key (F).

Repeat the procedure with the other three legs.

Make sure all the bolts are fully tightened.

Carefully turn your table upright.

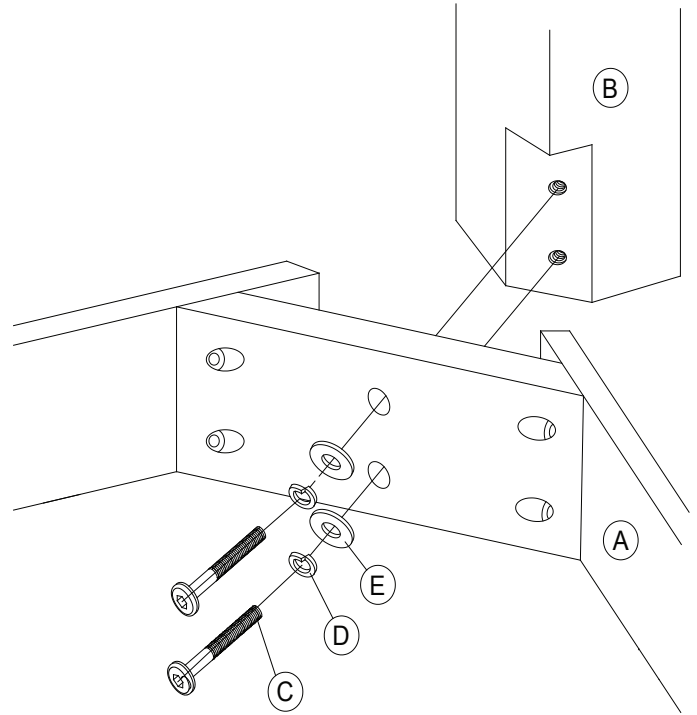

Dining Table

Assembly Instructions - Please keep for future reference

602/9669

603/0940

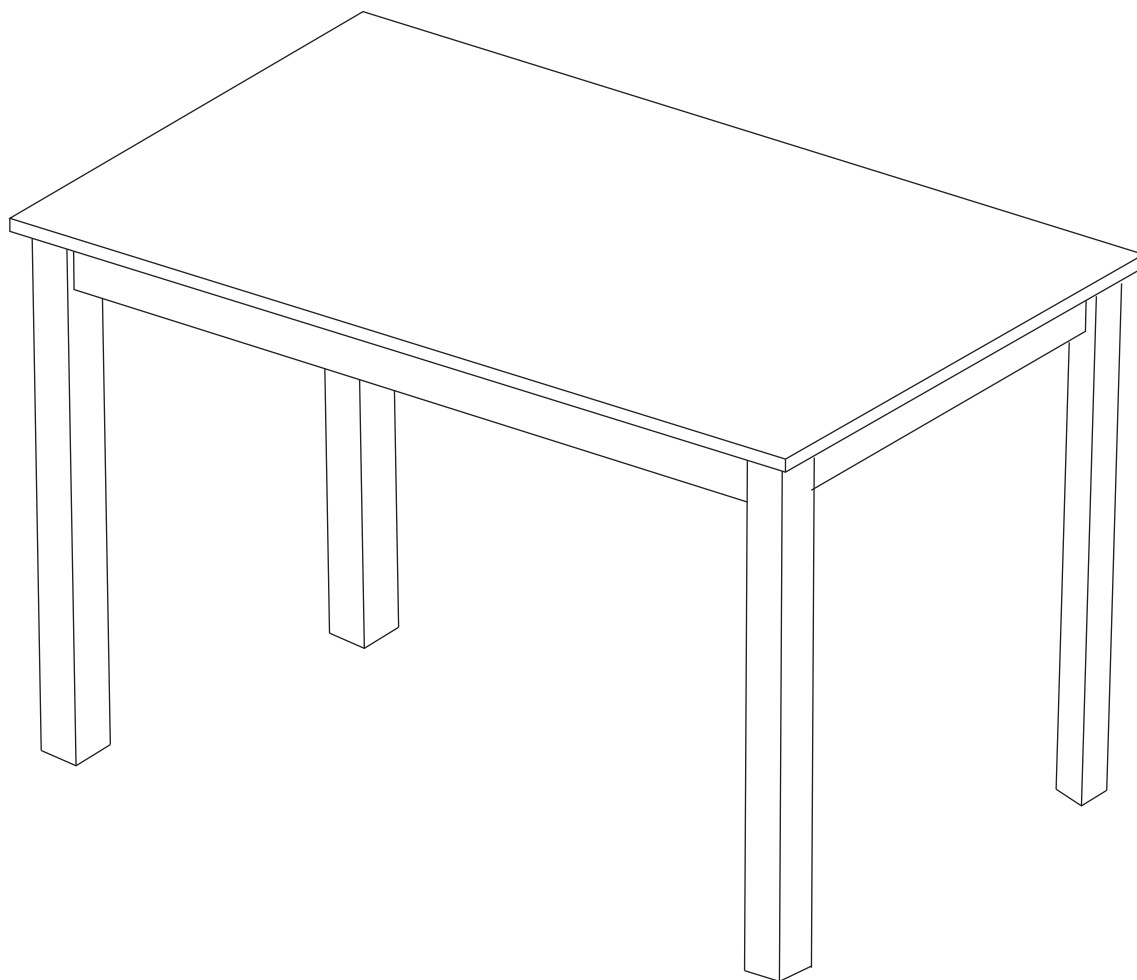

Dimensions

Width - 90cm

Length - 150cm

Height - 74cm

Important Please read these instructions fully before starting assembly

If you need help or have damaged or missing parts, call the Customer Helpline:0845 6400 800



Safety and Care Advice

Important Please read these instructions fully before starting assembly

- Check you have all the components and tools listed on pages 2 and 3.
- Remove all fittings from the plastic bags and separate them into their groups.
- Keep children and animals away from the work area, small parts could choke if swallowed.
- Make sure you have enough space to layout the parts before starting.

- Do not stand or put weight on this product during assembly, this could cause damage.
- Assemble the item as close to its final position (in the same room) as possible.
- Assemble on a soft level surface to avoid damaging the unit or your floor.
- Parts of the assembly will be easier with 2 people.



- We do not recommend the use of power drill/drivers **for inserting screws**, as this could damage the unit. Only use hand screwdrivers.
- Dispose of all packaging carefully and responsibly.

Care and maintenance

- Only clean using a damp cloth and mild detergent, do not use bleach or abrasive cleaners.
- From time to time check that there are no loose screws on this unit.
- This product should not be discarded with household waste. Take to your local authority waste disposal centre.

Components - Panels

Please check you have all the panels listed below

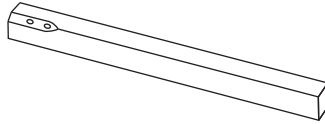
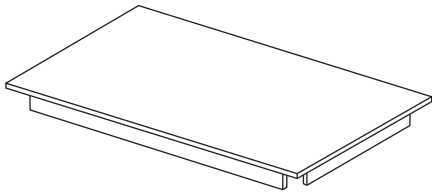

1 Table Top





2 Table Leg x 4

Components - Fittings

If you have damaged or missing components, call the Customer Helpline: 0845 6400 800

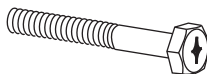
Please check you have all the fittings listed below

Note: The quantities below are the correct amount to complete the assembly. In some cases more fittings may be supplied than are required.

<p>A </p> <p>65mm Hex Bolt</p>	<p>B </p> <p>Spring washer x 8</p>	<p>C </p> <p>Flat washer x 8</p>
<p>D </p> <p>Hex Screw Spanner</p>		

Tools required

Ruler - Use this ruler to help correctly identify the screws

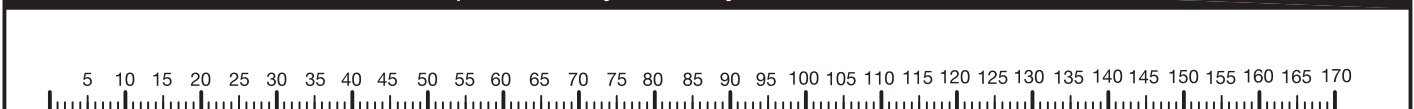

Assembly Instructions

Step 1

Table Leg

Locate the table leg **2** at 4 corners of table top **1**.

Assemble hex bolt **A**, spring washers **B** and flat washer **C** through corner block using hex spanner **D**

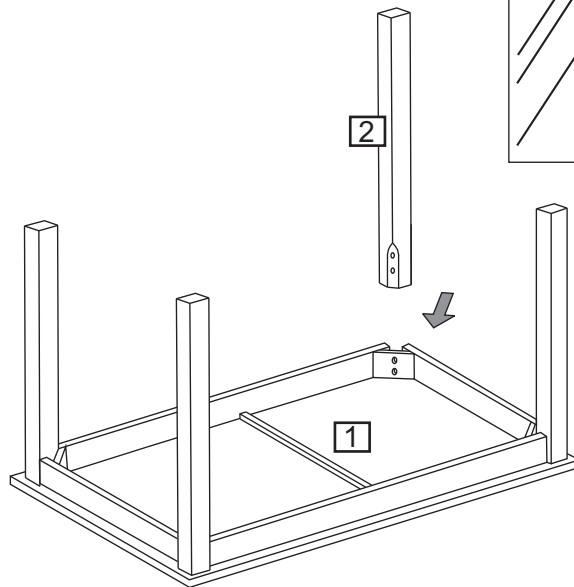
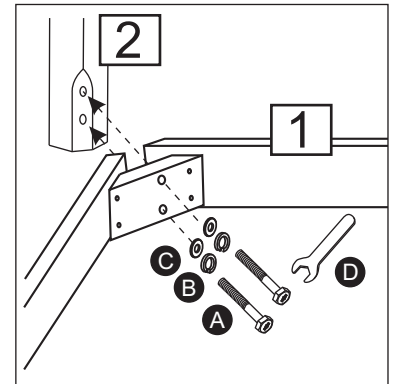

Tighten the bolts, and repeat for all legs.

Step 2

Carefully turn the table over, and put the table on the floor

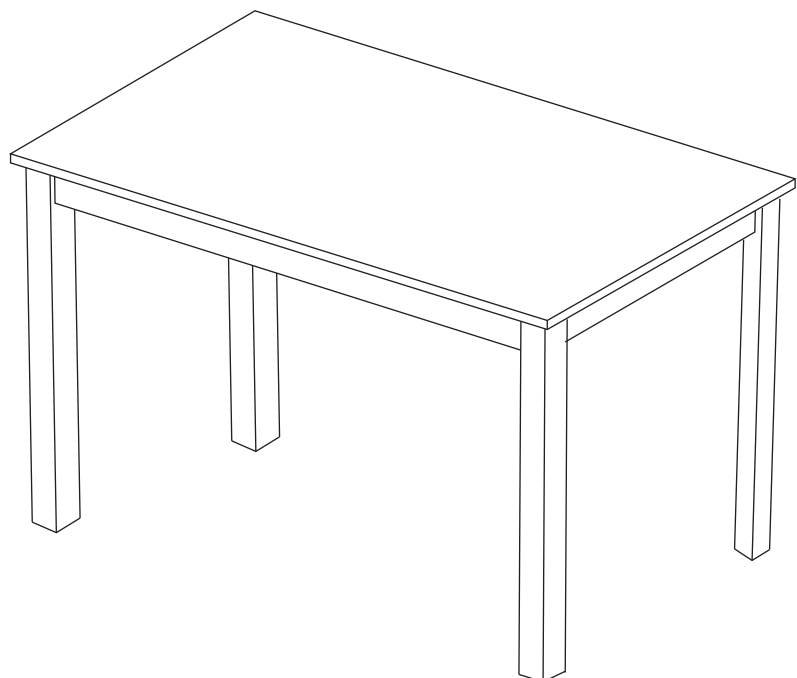

The assembly is complete.

Dining Table

Assembly Instructions - Please keep for future reference

602/9669

603/0940

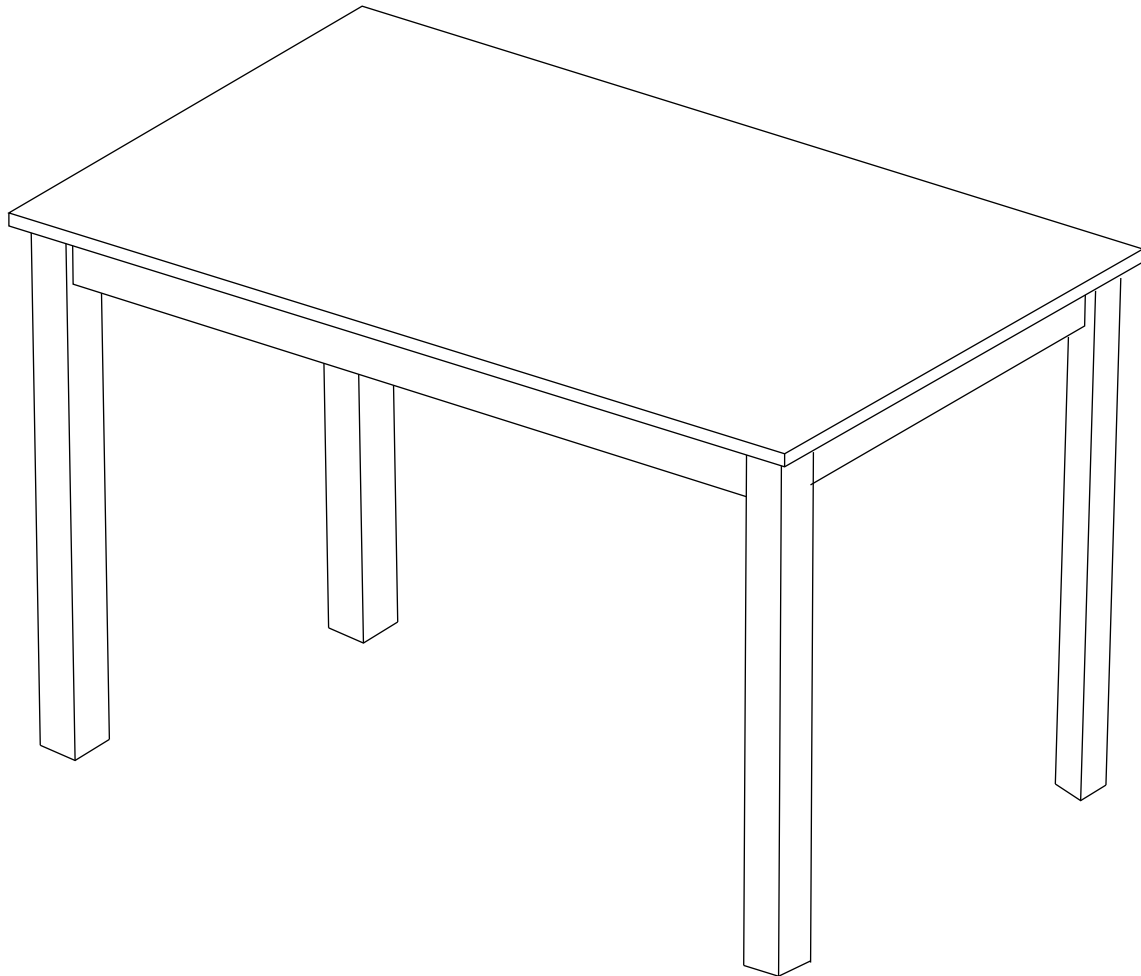

Dimensions

Width - 90cm

Deep - 150cm

Height - 74cm

Important Please read these instructions fully before starting assembly

If you need help or have damaged or missing parts, call the Customer Helpline: 0845 6400 800



Safety and Care Advice

Important Please read these instructions fully before starting assembly

- Check you have all the components and tools listed on pages 2 and 3.
- Remove all fittings from the plastic bags and separate them into their groups.
- Keep children and animals away from the work area, small parts could choke if swallowed.
- Make sure you have enough space to layout the parts before starting.

- Do not stand or put weight on this product during assembly, this could cause damage.
- Assemble the item as close to its final position (in the same room) as possible.
- Assemble on a soft level surface to avoid damaging the unit or your floor.
- Parts of the assembly will be easier with 2 people.



- We do not recommend the use of power drill/drivers **for inserting screws**, as this could damage the unit. Only use hand screwdrivers.
- Dispose of all packaging carefully and responsibly.

Care and maintenance

- Only clean using a damp cloth and mild detergent, do not use bleach or abrasive cleaners.
- From time to time check that there are no loose screws on this unit.
- This product should not be discarded with household waste. Take to your local authority waste disposal centre.

Components - Panels

Please check you have all the panels listed below

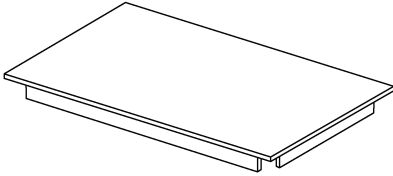

1 Table Top x 1
(150 x 90)cm

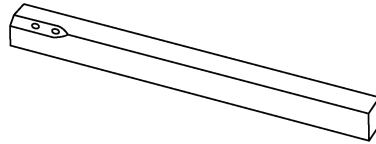



2 Table Leg x 4
(72 x 5.4)cm

Components - Fittings

If you have damaged or missing components, call the **Customer Helpline**: 08456 400800

Please check you have all the panels listed below

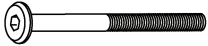
Note: The quantities below are the correct amount to complete the assembly. In some cases more fittings may be supplied than are required

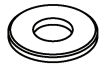
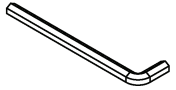
<p>A </p> <p>JCBB Screw M8 x 70 x 8</p>	<p>B </p> <p>Spring Washer 5/16" x 8</p>	<p>C </p> <p>Flat Washer 5/16" x 8</p>
<p>D </p> <p>5mm Hex Key x 1</p>		

Tools required

Ruler - Use this ruler to help correctly identify the screws

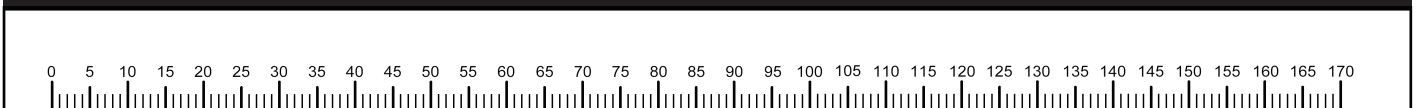

Assembly Instructions

Step 1

Table Leg

Locate the table leg **2** at 4 corners of table top **1**.

Assemble bolts **A**, spring washers **B** and flat washer **C** through corner block using hex key **D**.

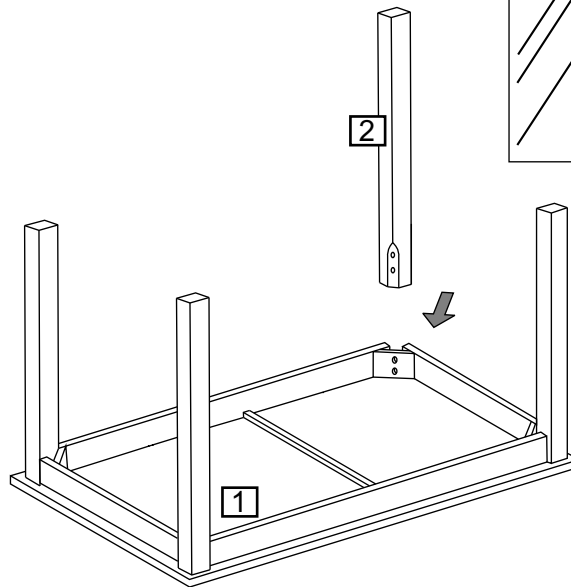
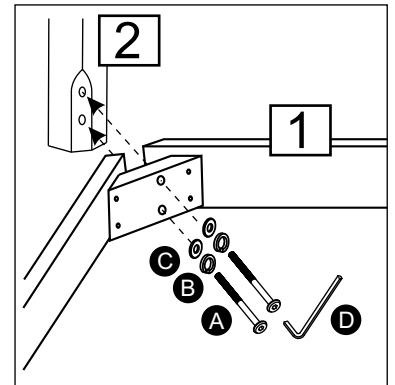

Tighten the bolts, and repeat for all legs

Step 2

Carefully turn the table over, and put the table on the floor

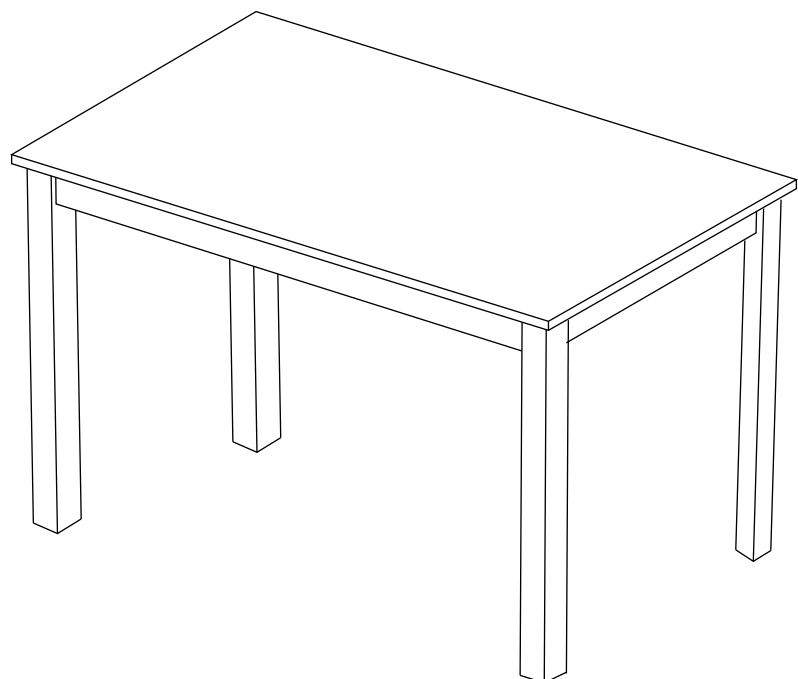

The assembly is complete.

Dining Chair

Assembly Instructions - Please keep for future reference

600/1584

603/2364

603/0452

600/3654

160/609

603/0830

603/2333

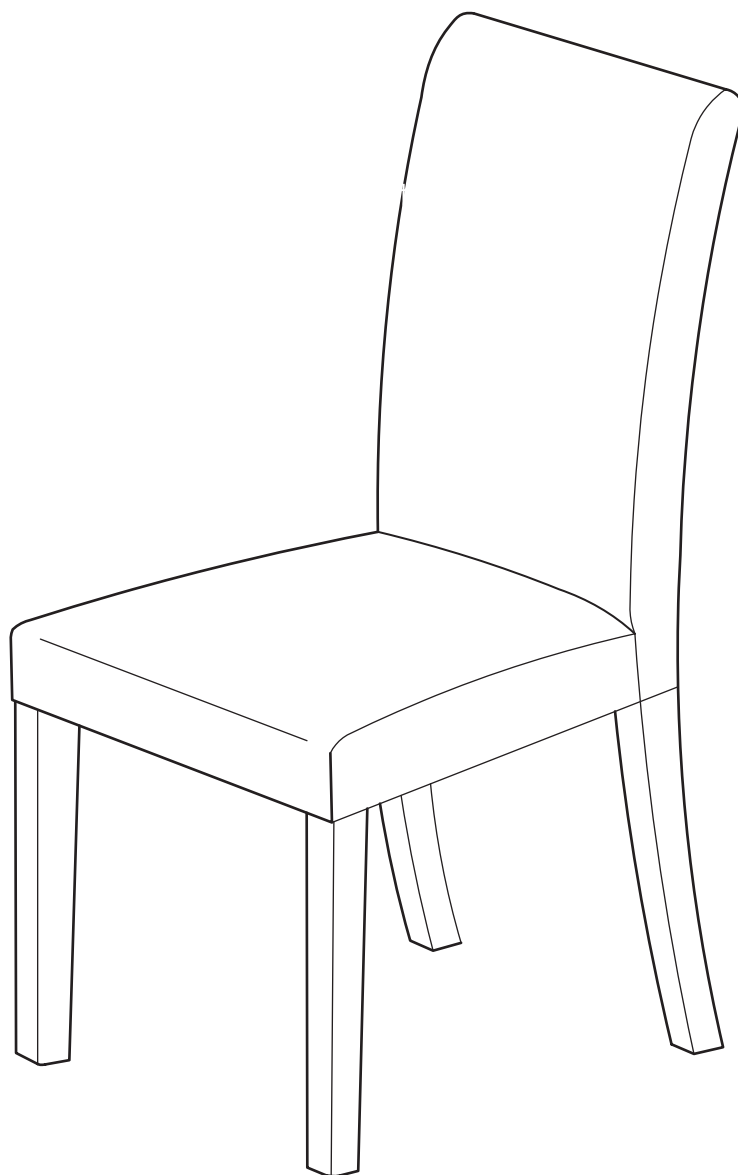

Dimensions

Width - 43.5cm

Deep - 52.5cm

Height - 92cm

Important Please read these instructions fully before starting assembly

If you need help or have damaged or missing parts, call the **Customer Helpline: 0845 640 0800**



afety and Care Advice

Important Please read these instructions fully before starting assembly

- Check you have all the components and tools listed on pages and .
- Remove all fittings from the plastic bags and separate them into their groups.
- Keep children and animals away from the work area, small parts could choke if swallowed.
- Make sure you have enough space to layout the parts before starting.

- Do not stand or put weight on the product, this could cause damage.
- Assemble the item as close to its final position (in the same room as possible).
- Assemble on a soft level surface to avoid damaging the unit or your oor.
- Parts of the assembly will be easier with people.



- We do not recommend the use of power drill drivers **for inserting screws**, as this could damage the unit. Only use hand screwdrivers.
- Dispose of all packaging carefully and responsibly.

Care and maintenance

- Only clean using a damp cloth and mild detergent, do not use bleach or abrasive cleaners.

- From time to time check that there are no loose screws on this unit.

- This product should not be discarded with household waste. Take to your local authority waste disposal centre.

Components - Panels

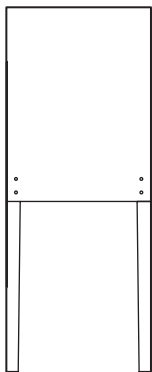

1 Back frame (36.5 x 92cm)

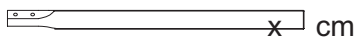

2 Leg x 2 (3.2 43)

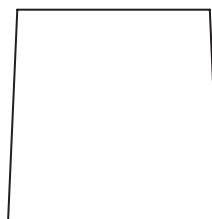



3 Box seat (43.5 x 41.5cm)

Components - Fittings

If you have damaged or missing components, call the **Customer Helpline: 0845 640 0800**

Please check you have all the fittings listed below

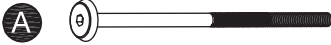
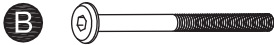
Note: The quantities below are the correct amount to complete the assembly. In some cases more fittings may be supplied than are required.

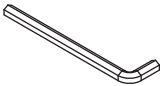
 <p>A</p> <p>M6x85mm Bolt x 8</p>	 <p>B</p> <p>M6x55mm Bolt x 10</p>	 <p>C</p> <p>Ø18x1mm Washer x 18</p>
 <p>D</p> <p>Ø11x1.5mm Spring washer x 16</p>	 <p>E</p> <p>4mm Hex Key x 1</p>	

Tools required



Ruler/tape
measure

Ruler - Use this ruler to help correctly identify the screws

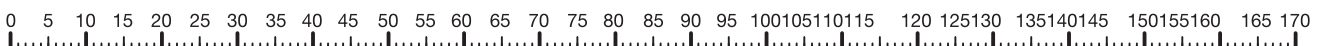

Assembly Instructions

Step 1

Fitting legs

Locate the corners of the box seat opposite to the center hole.

Insert the legs **2** into the corners of the box seat **3**.

Assemble bolts **B**, spring washers **D** and washers **C** through each corner block of the box seat **3** using hex key **E**.

Tighten the bolts.

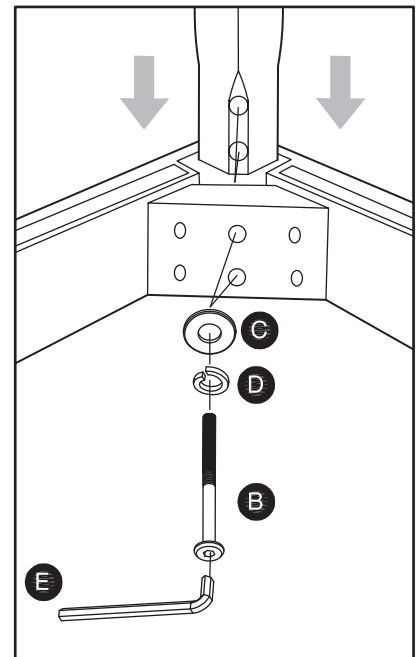
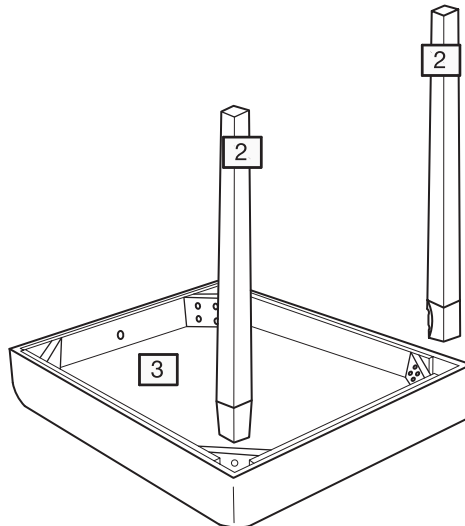

Step 2

Attaching back frame

Place the box seat **3** on the back frame **1**.

Assemble the bolt **B** and washer **C** onto the back frame **1** using hex key **E**.

Do not tighten the bolts at this point.

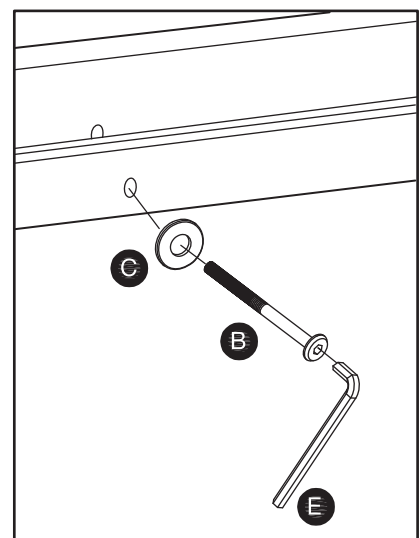
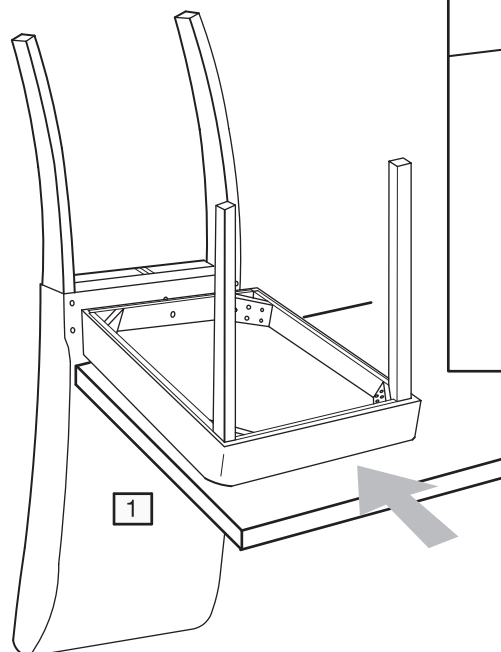

Assembly Instructions

Step 3

Fitting bolts

Assemble bolts **A**, spring washers **D** and washers **C** through each corner block of the box seat **3** to the back frame **1**.

Do not tighten the bolts at this point in time.

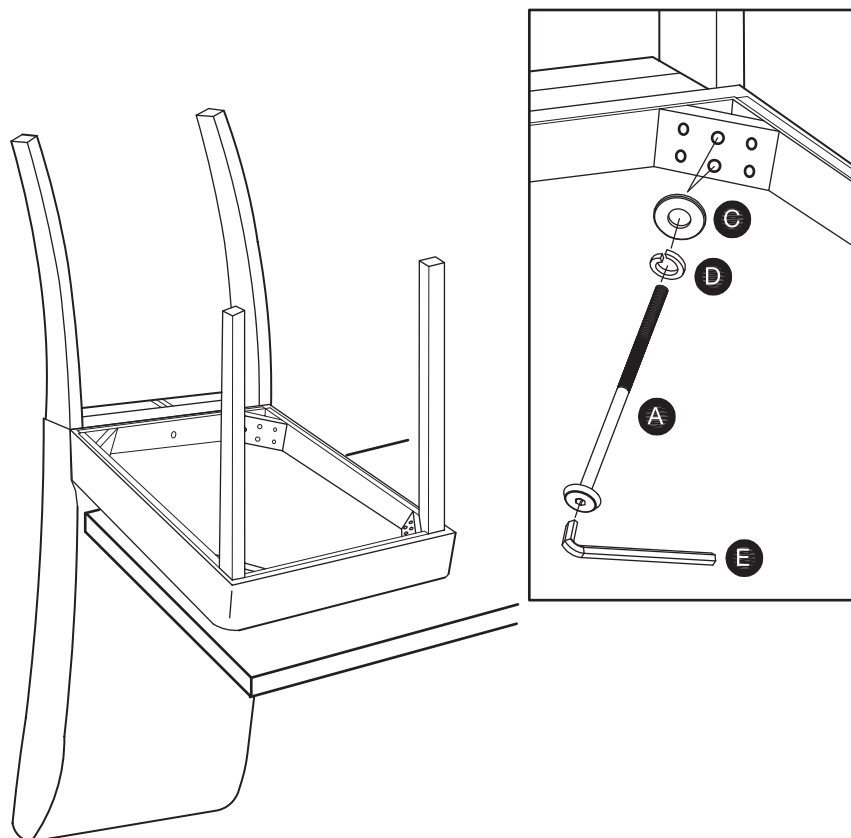

Step 4

Carefully turn the chair over, and put the chair on the oor.

Step 5

Tighten each loose bolt a little at a time while making sure the chair remains level. Repeat until all loose bolts are tight.

Repeat with remaining chairs.

