

Savannah Dining Table

Assembly Instructions – Please keep for future reference

602/3919

603/1217

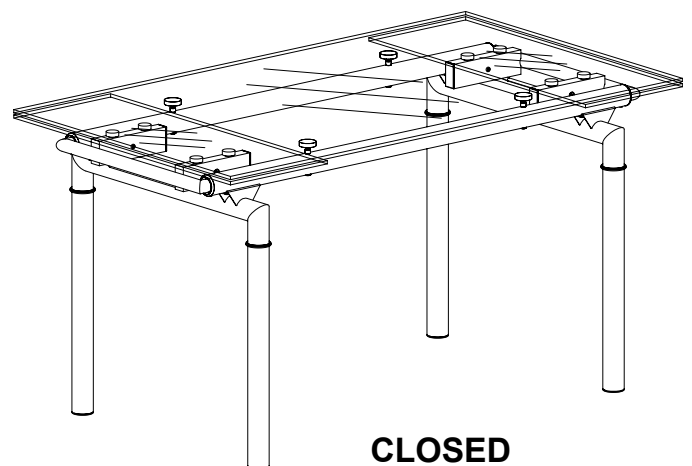
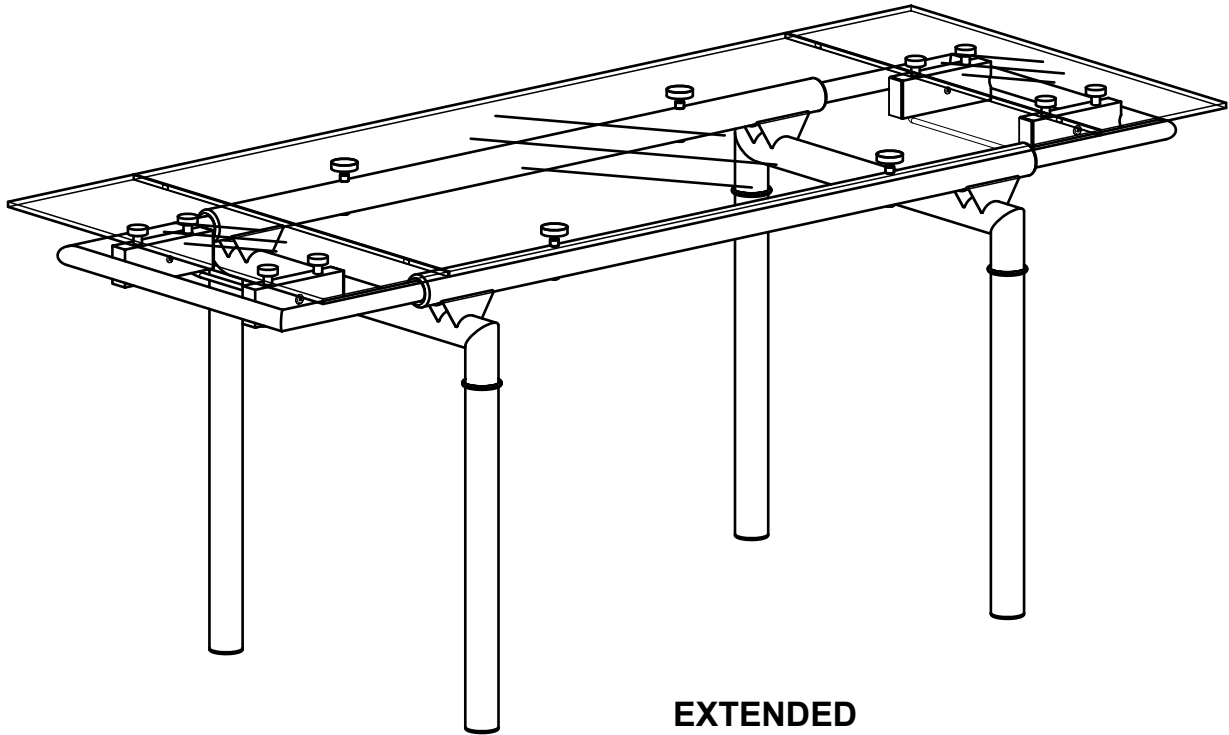

Dimensions

Extended	Closed
Width - 200cm	Width - 140cm
Depth - 80cm	Depth - 80cm
Height - 75cm	Height - 75cm

Important – Please read these instructions fully before starting assembly

If you need help or have damaged or missing parts, call the Customer Helpline: 01799 513466



Safety and Care Advice

Important – Please read these instructions fully before starting assembly

- Check you have all the components and tools listed on pages 2 and 3.
- Remove all fittings from the plastic bags and separate them into their groups.
- Keep children and animals away from the work area, small parts could choke if swallowed.
- Make sure you have enough space to layout the parts before starting.
- Do not stand or put excessive weight on the product, this could cause damage.
- Assemble the item as close to its final position (in the same room) as possible.
- Parts of the assembly will be easier with 2 people.
- Dispose of all packaging carefully and responsibly.
- Place the product on flat and steady surface during use.
- Assemble on a soft level surface to avoid damaging the unit or your floor.
- Keep these instructions for further use.
- To ensure an easier assembly, we strongly advise that all fittings are only finger tightened during initial assembly. Only upon completion of the assembly should all fixing points be fully tightened.

Glass safety

- This product complies with BS7376: 2004.
- Imported by:
Justwise Group Ltd
6 The Shires
Shirehill Industrial Estate
Saffron Walden
Essex
CB11 3AP
- Product stock ref: DTSAV (Clear Glass)
DTSAVB (Black Glass)
- P/O No:
- If the glass is chipped or broken, stop using the product and consult the Manufacturer of Supplier.

WARNINGS

- a) Do not place very hot or very cold items on the glass surface(s) unless adequately thick table mats are used to prevent such items from coming into contact with the glass..
- b) Do not sit or stand upon the glass surface(s).
- c) Do not use the glass as a chopping surface. Do not strike the glass with hard or pointed items.
- d) When cleaning glass panels use a damp cloth or leather with washing up liquid or soft soap if necessary, do not use washing powders or any other substance containing abrasives since these substances scratch glass.

Care and maintenance

- Only clean using a damp cloth and mild detergent, do not use bleach or abrasive cleaners.
- From time to time check that there are no loose screws on this unit.
- This product should not be discarded with household waste. Take to your local authority waste disposal centre.

Components - Parts

Please check you have all the parts listed below

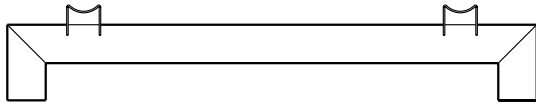

1 Leg frame x 2
(70 x 12.6cm)

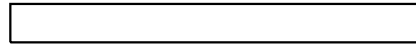

2 Leg x 4
(54.8 x Ø5.1cm)

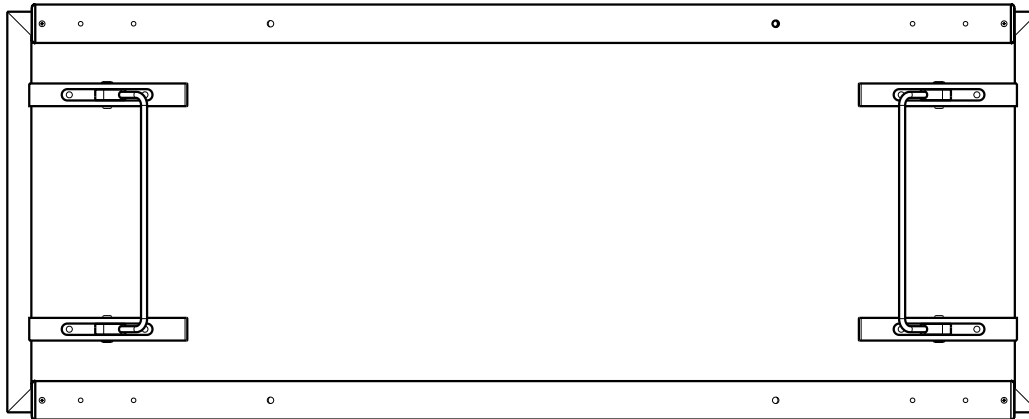

3 Top frame (138 x 60.7cm)

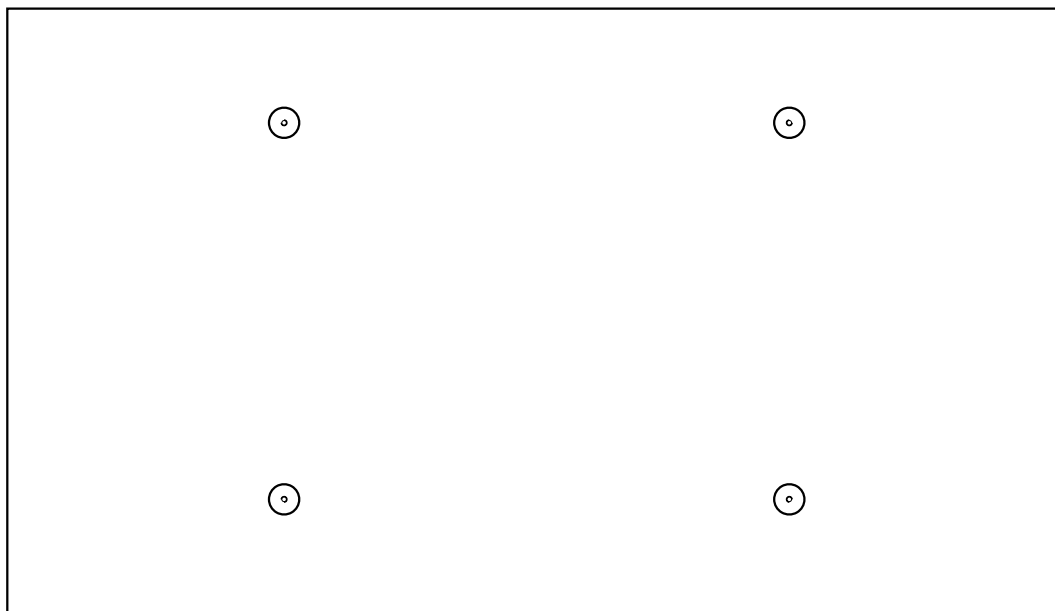

4 Glass top (140 x 80cm)

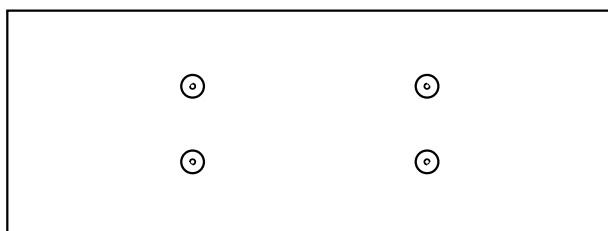











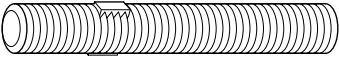

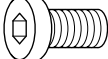
5 Glass extension leaves x 2 (80 x 30cm)

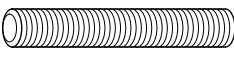
Components - Fittings

If you have damaged or missing components, call the **Customer Helpline: 01799 513466**

Please check you have all the fittings listed below

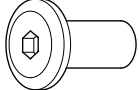
Note: The quantities below are the correct amount to complete the assembly. In some cases more fittings may be supplied than are required.

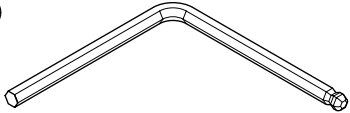
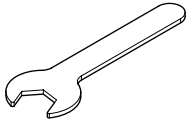
<p>A</p>  <p>75mm Large stud x 4</p>	<p>B</p>  <p>Leg spacer x 4</p>	<p>C</p>  <p>13mm Allen screw x 16</p>
<p>D</p>  <p>Spring washer x 8</p>	<p>E</p>  <p>Ø16mm Plain washer x 8</p>	<p>F</p>  <p>68mm Medium stud x 4</p>
<p>G</p>  <p>Nut x 4</p>	<p>H</p>  <p>10mm Threaded spacer x 4</p>	<p>J</p>  <p>15mm Short stud x 8</p>
<p>K</p>  <p>Rubber washer x 8</p>	<p>L</p>  <p>14mm Threaded spacer x 8</p>	<p>M</p>  <p>Ø18mm Plain washer x 4</p>
<p>N</p>  <p>Nut x 4</p>	<p>O</p>  <p>Rubber pad x 4</p>	<p>P</p>  <p>Allen key x 1</p>
<p>Q</p>  <p>Spanner x 1</p>		

Tools required



Ruler/tape
measure

Ruler – Use this ruler to help correctly identify the screws



Assembly Instructions

Step 1

Assembling leg frames

Place leg frame **1** upside down onto the floor.

Screw large threaded rods **A** into leg frames **1** as shown.

Note: Screw the short end in until it stops.

Locate leg spacers **B** over the threaded rods.

Screw legs **2** onto threaded rods and tighten.

Repeat for other leg frame.

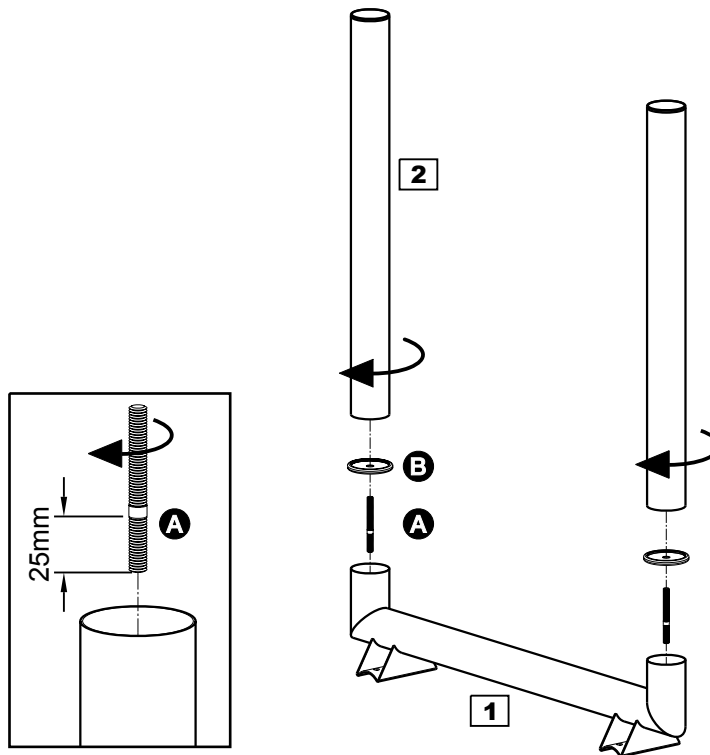

Step 2

Assembling side rails

Place top frame **3** upside down onto a clean flat surface.

Assemble leg frames to the top frame using fixings **C**, **D** and **E**.

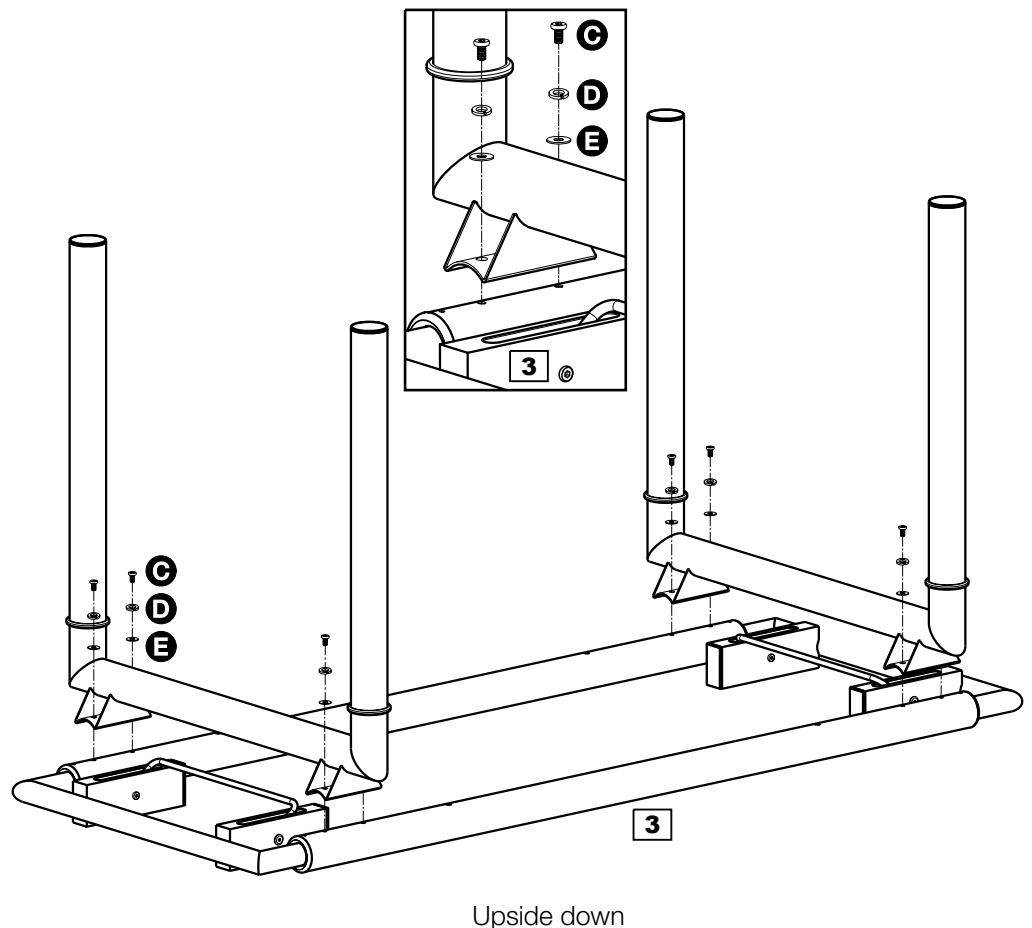

Upside down

Assembly Instructions

Step 3

Preparing glass top

Place glass top **4** upside down onto a clean flat surface.

Screw medium threaded rods **F** into the metal discs on the underside of glass top **4**.

Screw nuts **G** onto threaded rods and use the spanner to tighten onto the metal discs.

Screw threaded spacers **H** half way onto the threaded rods.

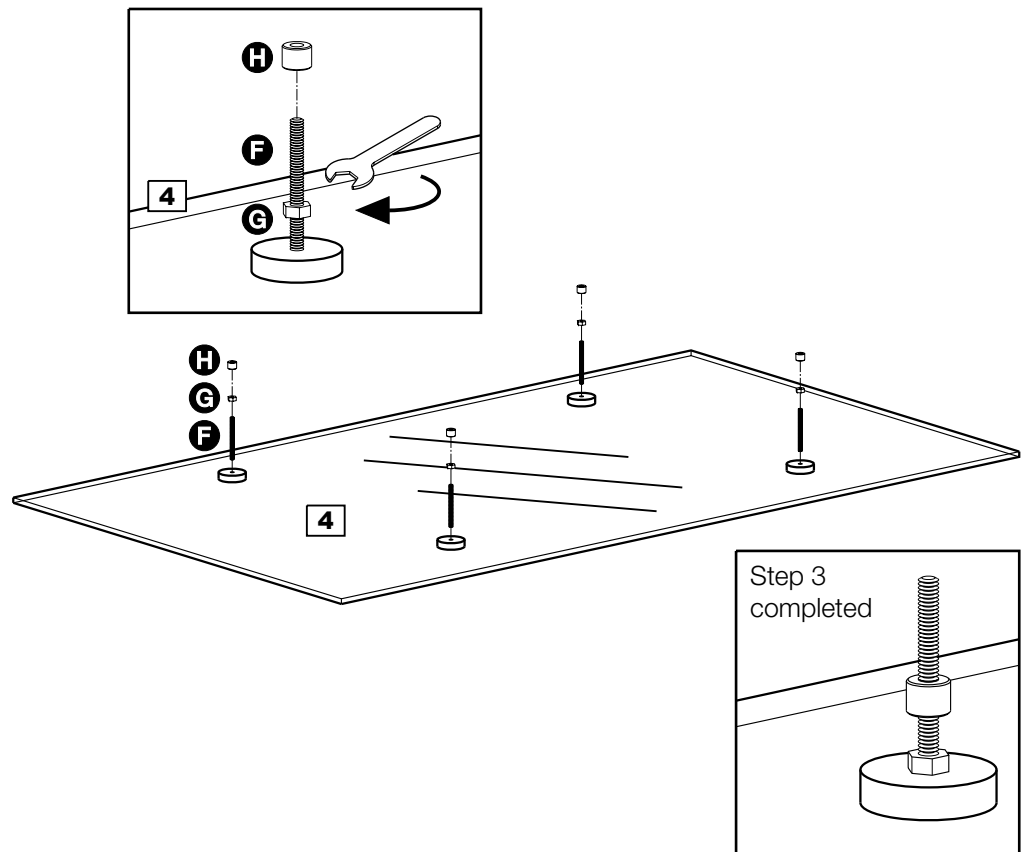

Step 4

Preparing extension leaves

Place extension leaves **5** upside down onto a clean flat surface.

Screw short threaded rods **J** into the metal discs on the underside of extension leaves **5**.

Locate rubber washers **K** over the rods.

Screw threaded spacers **L** onto the rods and tighten.

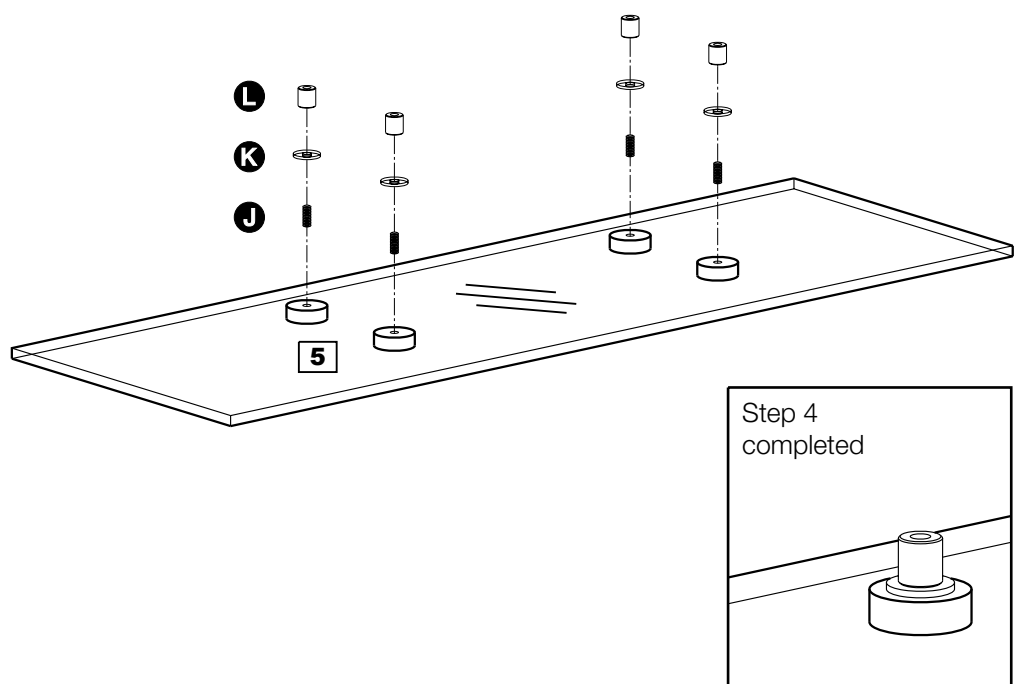

Assembly Instructions

Step 5

Attaching extension leaves

With help, turn frame over into its standing position.

Carefully align glass extension leaves **5** with the brackets on the frame.

Secure from underneath using fixings **C**.

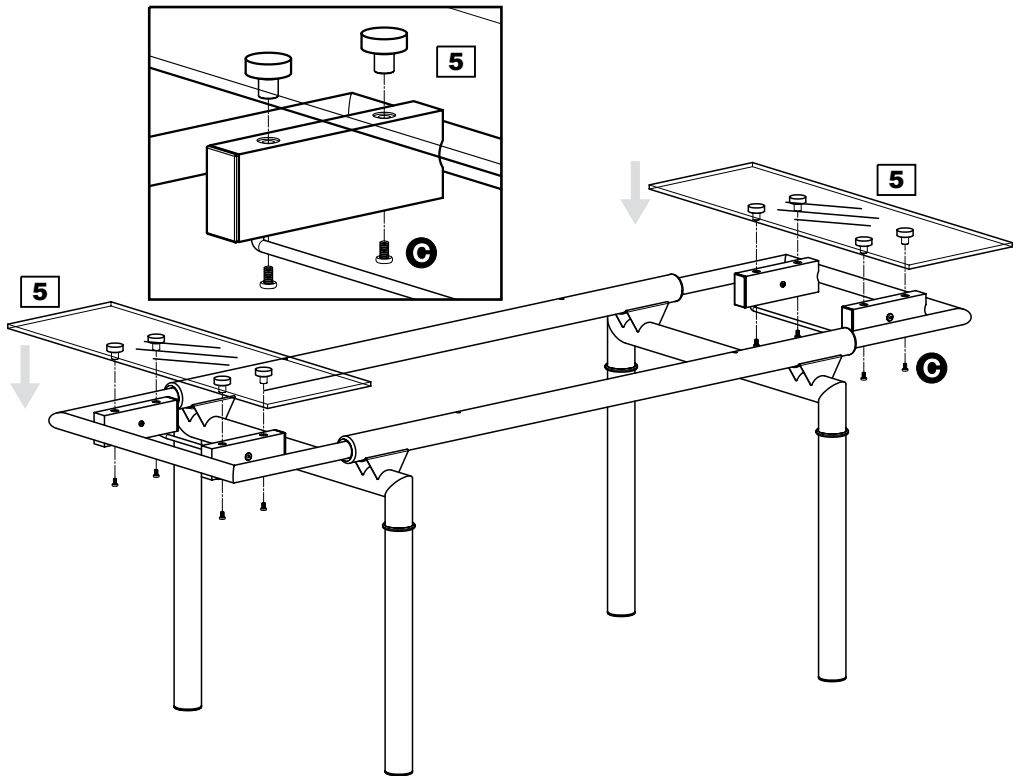

Step 6

Attaching main glass top

With help, carefully lower main glass top **4** down into position.



Warning:

The glass top is heavy, lift with care.

Following the extension procedure described in step 7, raise the extension leaves into the extended position.

a: Threaded spacers **H** can be turned to adjust the height of the glass top and achieve alignment with the extension leaves.

b: Once alignment is achieved, secure main glass top using fixings **M** and **N**.

Small rubber pads **O** can be located onto the edge of the extension leaves to prevent direct glass to glass contact.

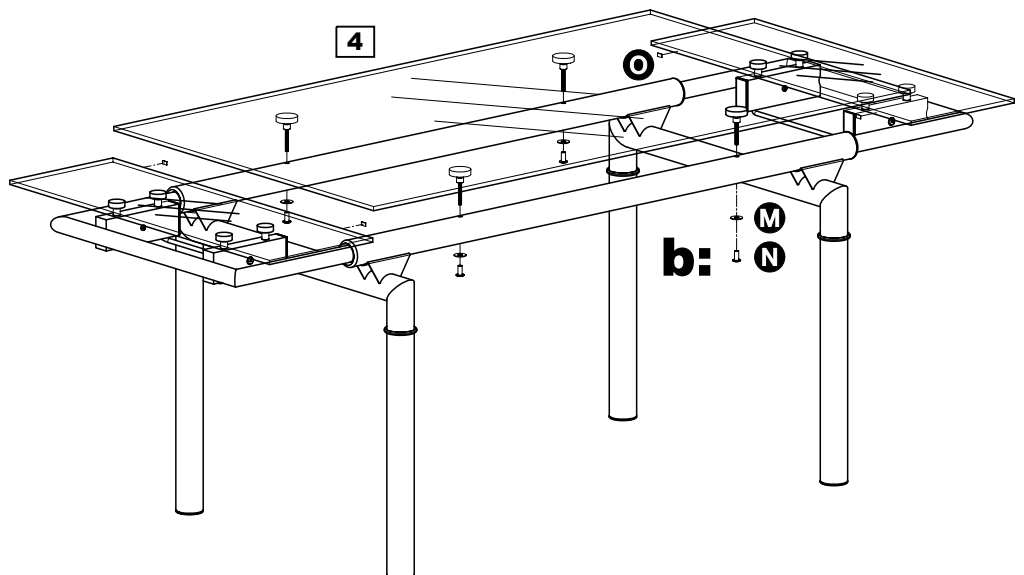
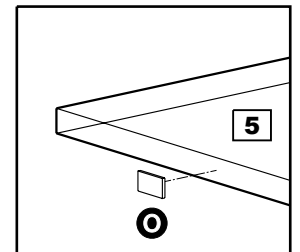
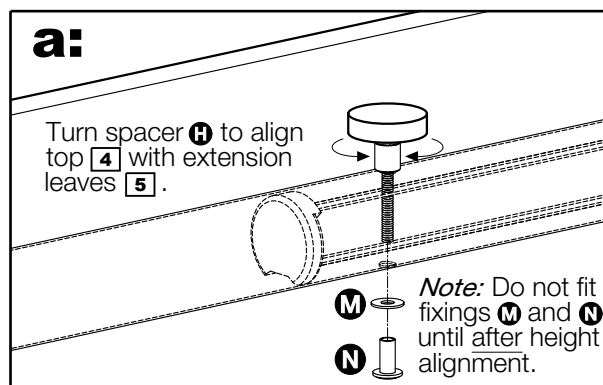

Assembly Instructions

Step 7

Extending and closing

TO EXTEND

Pull extension leaf out from below the main glass top until it stops.

Push down on the handlebar to raise the extension leaf.

Once raised, push the extension leaf back in until it touches the main glass top.

TO CLOSE

Repeat the above in reverse order, expect the handlebar should be raised to lower the extension leaf.



Warning:

Keep fingers clear of glass contact area when closing/extending the leaves!

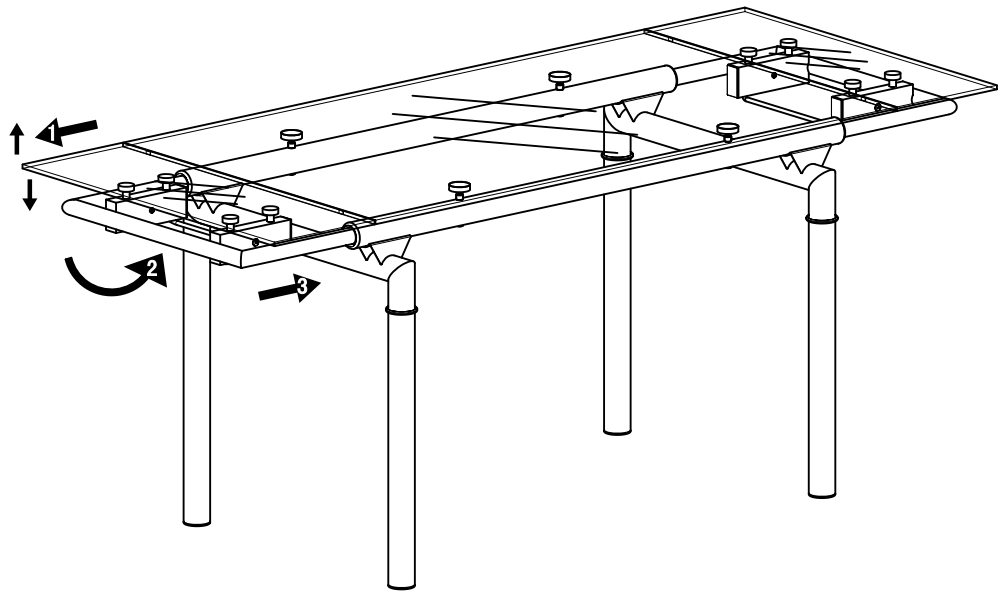

Assembly is complete.

If you need help or have damaged or missing parts, call the **Customer Helpline: 01799 513466**
Justwise Group Ltd., 6 The Shires. Shire Hill Industrial Estate. Saffron Walden. Essex. CB11 3AP

SAVANNAH DINING CHAIR











Assembly Instructions

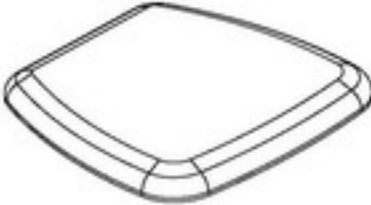

Before you
start, here
is some
helpful advice

1. We suggest you spend a short time reading through this leaflet and then follow the simple step by step instructions.
2. If you follow the instructions carefully the end result should be worth the effort.
3. Do not discard any of the packaging until you have checked that you have all the parts and the pack of fittings.
4. Assemble this product on a carpet.
5. To ensure an easier assembly, we strongly advise that all fittings are only finger tightened during initial assembly. Only upon completion of the assembly should all fixing points be fully tightened.
6. We recommend a periodic check on all fixing points to make sure they remain fully tightened.
7. Keep glue and fittings out of children's reach.

Component parts and fittings contained in the box

PARTS	FITTINGS
 <p>① QTY-2PCS</p>	<p>Ⓐ Long QTY-4</p> 
 <p>② QTY-2PCS</p>	<p>Ⓑ Short QTY-4</p> 
	<p>Ⓒ Short QTY-8</p> 
 <p>③ QTY-2PCS</p>	<p>Ⓓ Long QTY-8</p> 
 <p>④ QTY-2PCS</p>  <p>⑤ QTY-2PCS</p>	<p>Ⓔ QTY-2</p> 

Note: Quantities shown are for a pair of chairs. (2PCS)

ASSEMBLY



BEFORE BEGINNING ASSEMBLY, PLEASE NOTE THE ENDS OF SEAT SUPPORT STRETCHER ③ ARE CUT AT AN ANGLE. (SEE EXPLODED DRAWING FOR ASSEMBLY GUIDANCE).

1) ASSEMBLE STRETCHER ③ IN BETWEEN FRONT LEG FRAMES ① AND ② USING FIXINGS ④.

STEP 1

NOTE: SCREWS ARE ON INSIDE OF FRAME.

NOTE: ANGLES ON ENDS.

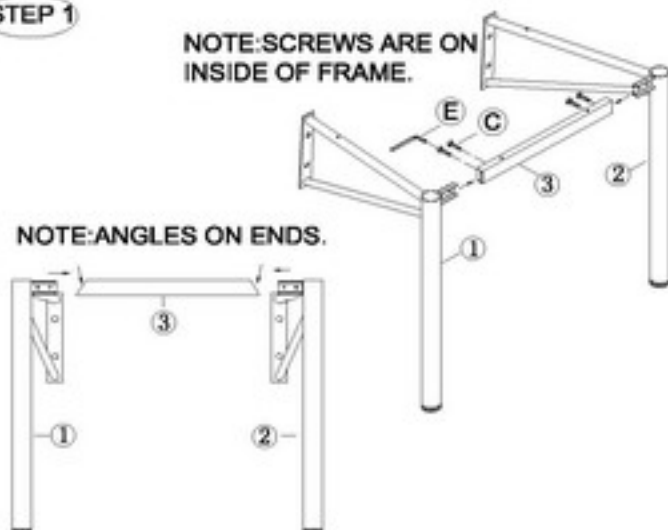

1) ASSEMBLE FRONT LEG ASSEMBLY TO CHAIR BACK USING FIXINGS ④.

STEP 2

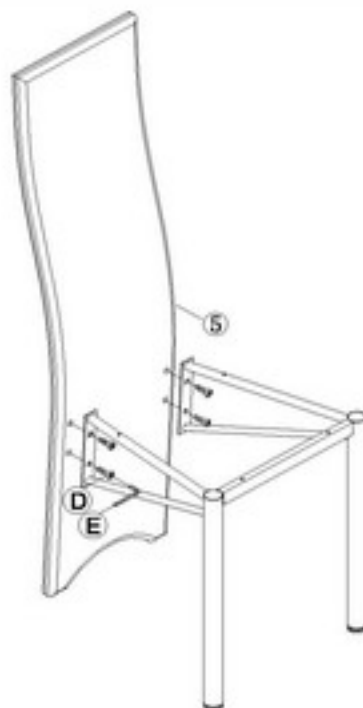

ASSEMBLY



1) PLACE SEAT PAD ④
UPSIDE DOWN ON A
CLEAN FLAT SURFACE
(I.E EDGE OF TABLE)

2) CAREFULLY ALIGN
THE FRAME ON THE
SEAT PAD AND SECURE
USING LONG SCREWS
Ⓐ AT THE FRONT
(THROUGH SEAT
SUPPORT ③), AND
SHORT SCREWS Ⓑ ON
EACH SIDE.

STEP 3

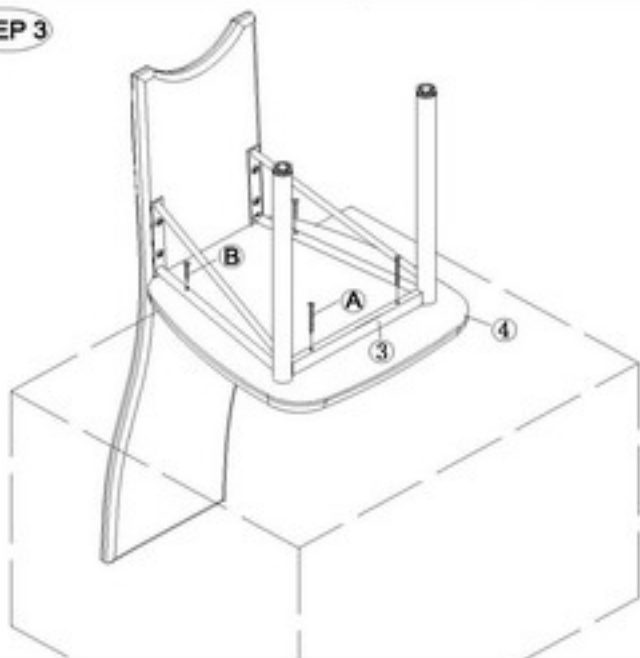

1) STAND THE UNIT
UPRIGHT AND ADJUST
THE HEIGHT
ADJUSTABLE FEET TO
ACHIEVE A STABLE BASE

STEP 4



IMPORTANT INFORMATION-DO NOT REMOVE

Foam cushions

Reversible cushions should be turned regularly
Switch positions where possible

This will help prevent excessive soiling and wear to one side
OR

Fibre cushions

Must be given a vigorous "plumping" on a daily basis, ideally with the outer case zip opened to get air into the fibres and ensure the case fills the cushions to the correct shape. If plumping is not carried out, The fibres can form a mass causing a flat or uneven appearance.

CARE INFORMATION

Regular cleaning

Vacuum or use a soft brush weekly as accumulated dust and dirt will wear and dull the material

prolonged sunlight and heat

Avoid prolonged exposure to sunlight as this can cause fabric to fade. Protect it by drawing curtains or blinds
Avoid placing furniture too close to fires or radiators

Zips

Zips are fitted to assist in the ease of manufacture and do not necessarily mean the cover is removable for washing or cleaning

Loose Threads

Loose threads should be cut not pulled as this may unravel the weave

Beware of sharp or hot objects

Buckles, keys, toys and jewellery can easily snag on the fabric and cause tears and pulls
Do not allow pets to claw or climb on the furniture
Hot objects, such as heat from mugs or cups can permanently disfigure upholstery

Excessive force

Do not sit on the edge of cushions or arms as this can cause permanent damage
Restrain children from climbing or jumping on the furniture especially in shoes

Avoid

Wearing dark clothing especially denim jeans
Leaving newspapers lying on the furniture
Both of the above can result in dye/print being ground into the fabric and can result in cream/pale finishes going grey in colour

Cleaners are available from most supermarkets and hardware stores

BEFORE USING ANY CLEANING AIDS. PLEASE READ THE INSTRUCTIONS CAREFULLY AND TEST ON A HIDDEN AREA FIRST

Use of pictorial cleaning guidelines is recommended here but cannot contradict anything previously advised in writing

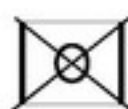
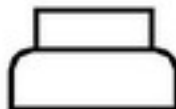

OPTIONAL: F&F label, including Batch ID NO and date of manufacture. Fabric composition.

CLEANING INFORMATION

Accidental spillage

Where possible:

Always tip liquid spillages from the surface of the fabric
Blot excess liquid with tissues or toilet roll
If necessary, sponge the area but do not over wet as water can shrink fabrics or their backing fibres
Remember to damp a complete panel to avoid marking
Always remove stains in the direction of the pile, if any
BE GENTLE - Do not rub or scrub as this only spreads the stain and can damage fabrics

General dirt and stains

Use a clean damp cloth (not wet) and if necessary use a gentle cleaning aid
Never use hot water as this can set stain into the fabric
Do not use detergents as these can cause colour loss and leave sticky residues
Follow cleaning symbol guidelines as shown below

Grease or oil based stains

Use a proprietary spot cleaner working from the edge of the stain inward to avoid spreading
If possible, treat the stain from the wrong side of the fabric and never use a hard scrubbing action

Water based stains

Use a specialist upholstery cleaner/shampoo
If a specialist cleaner is not available a very weak (2%)
Solution of washing powder can be used in hot or cold water
· Use the mixture sparingly
· Dab gently from the outer edge, inward
· Dab out shampoo afterwards using warm water

DO NOT SOAK

Savannah Dining Chair

Assembly Instructions – Please keep for future reference

602/5326

602/3988

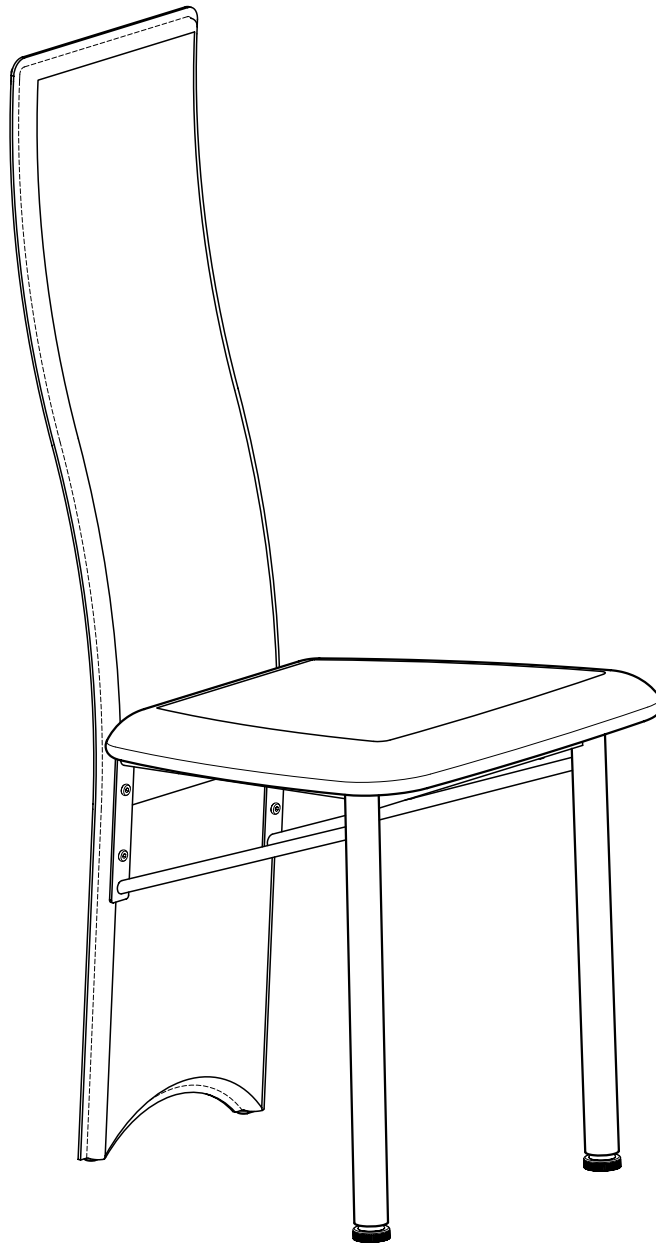

Dimensions

Width - 37.5cm

Depth - 54cm

Height - 106.5cm

Important – Please read these instructions fully before starting assembly

If you need help or have damaged or missing parts, call the **Customer Helpline: 08456 400800**



Safety and Care Advice

Important – Please read these instructions fully before starting assembly

- Check you have all the components and tools listed on pages 2 and 3.
- Remove all fittings from the plastic bags and separate them into their groups.
- Keep children and animals away from the work area, small parts could choke if swallowed.
- Make sure you have enough space to layout the parts before starting.

- Assemble the item as close to its final position (in the same room) as possible.
- Assemble on a soft level surface to avoid damaging the unit or your floor.
- Dispose of all packaging carefully and responsibly.
- Keep these instructions for further use.

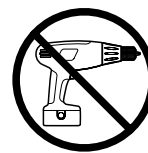

- We do not recommend the use of power drill/drivers **for inserting screws**, as this could damage the unit. Only use hand screwdrivers.
- To ensure an easier assembly, we strongly advise that all fittings are only finger tightened during initial assembly. Only upon completion of the assembly should all fixing points be fully tightened.

Cleaning Guidance

- Minor stains and spillages should be removed immediately from cushion fabric, by wiping over lightly with a damp cloth and mild soapy water.

- Light marking can also be removed using this method.

- To remove more stubborn stains or marking, a good quality proprietary domestic fabric cleaner can be used, although it should first be tested on an inconspicuous area of the fabric.

Care and maintenance

- From time to time check that there are no loose screws on this unit.

- This product should not be discarded with household waste. Take to your local authority waste disposal centre.

Components - Parts

Please check you have all the parts listed below

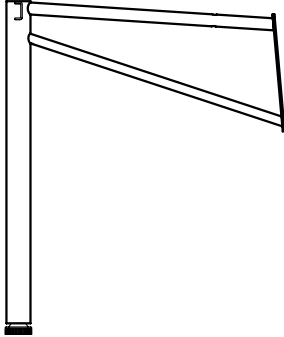

1 Left leg frame x 2
(44 x 37cm)

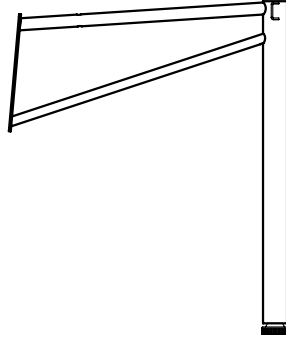

2 Right leg frame x 2
(44 x 37cm)

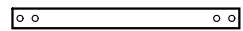

3 Stretcher x 2
(30 x 2.6cm)

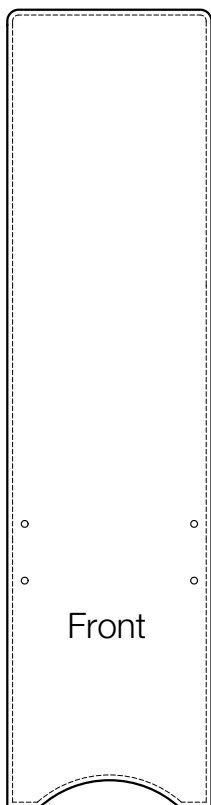

4 Backrest x 2
(106 x 27cm)

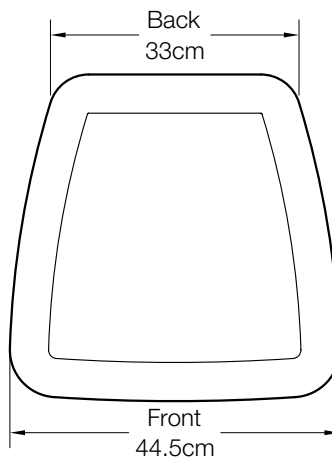

5 Seat pad x 2
(44.5 x 44cm)

Components - Fittings

If you have damaged or missing components, call the **Customer Helpline: 08456 400800**

Please check you have all the fittings listed below

Note: The quantities below are the correct amount to complete the assembly. In some cases more fittings may be supplied than are required.

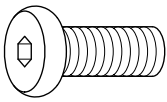
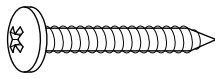
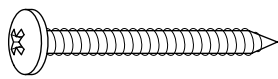
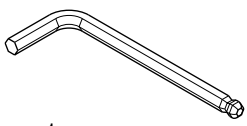
A  9mm Allen screw x 8	B  18mm Allen screw x 8	C  26mm Wood screw x 4
D  38mm Wood screw x 4	E  Allen key x 1	

Tools required

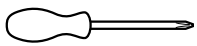

Phillips screwdriver
(medium & large)

Ruler – Use this ruler to help correctly identify the screws



Assembly Instructions

Step 1

Attaching legs

Assemble stretcher **3** in between left and right leg frames **1** and **2** using screws **A**.

Note: Ensure the arrow label on stretcher **3** is facing 'up' as shown.

Note: Do not fully tighten screws **A**.

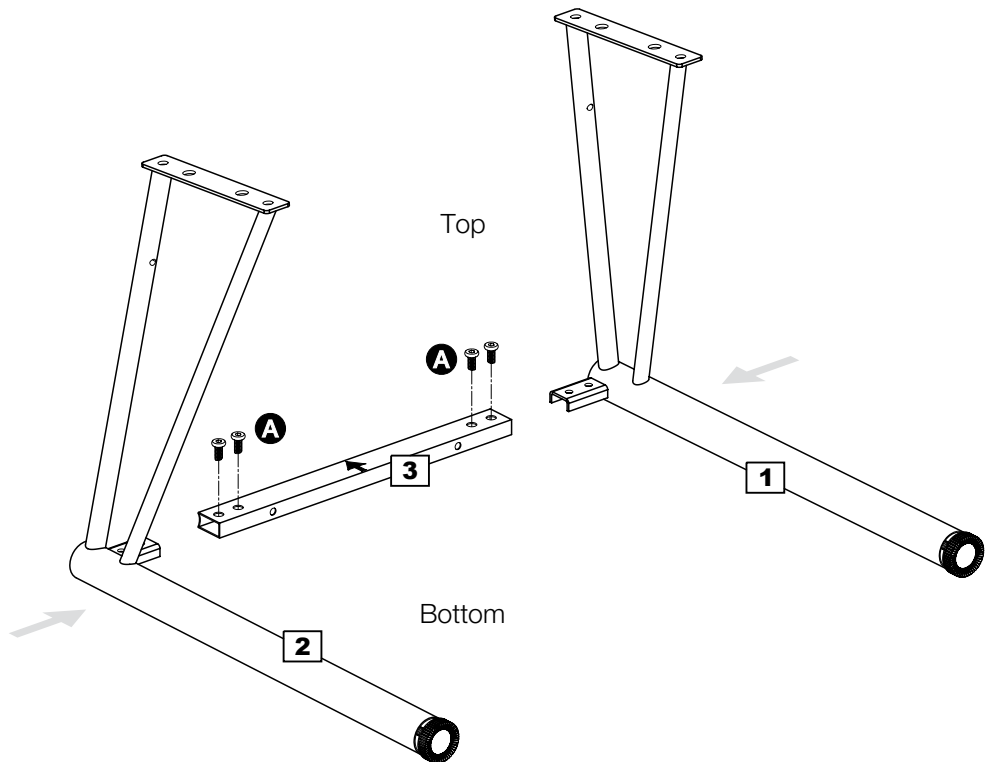

Step 2

Attaching backrest

Place backrest **4** down onto a clean flat surface.

Note: fixing holes must be facing up.

Turn the leg assembly over and place it onto the backrest **4** as shown.

Secure to the backrest using screws **B**.

Note: Do not fully tighten screws **B**.

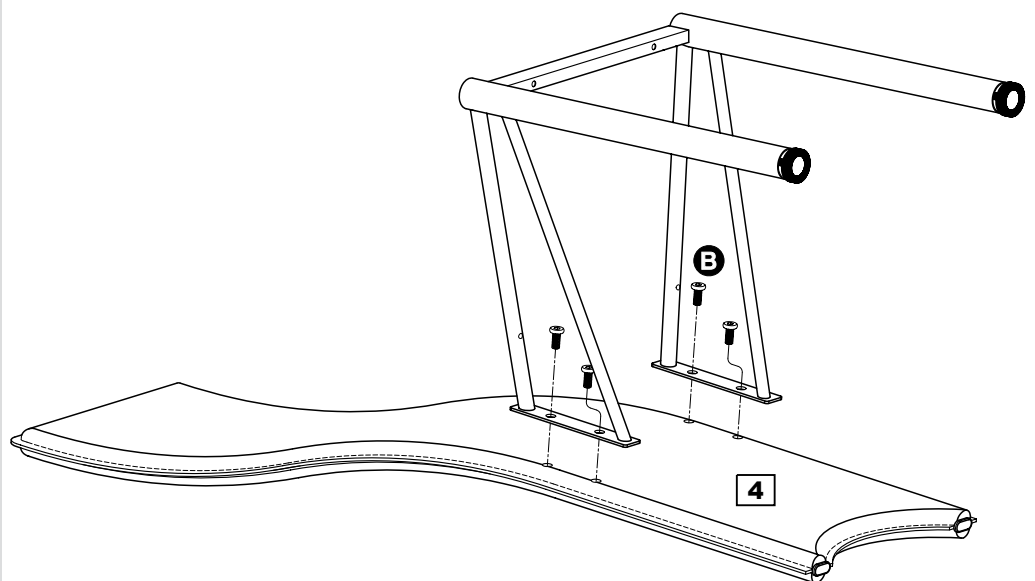

Assembly Instructions

Step 3

Attaching seat pad

Place seat pad **5** upside down onto a clean flat surface (edge of table top).

Align chair frame on top of seat pad and secure using screws **C** and **D**.

Note: Longer wood screws **D** go through stretcher **3** at the front.

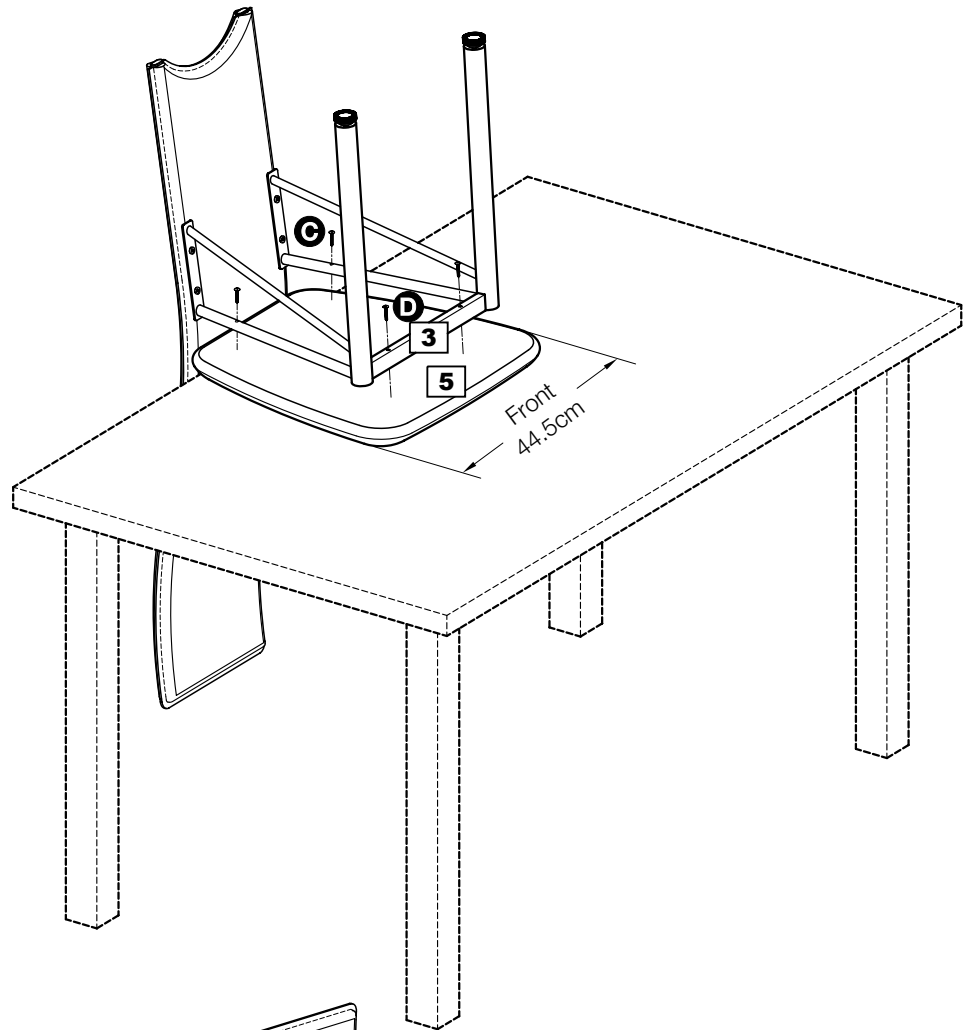

Step 4

Turn the chair upright

Stand the chair upright.

Whilst applying a firm downward pressure to ensure the chair is stable, fully tighten all screws.

If necessary, stability can be further adjusted using the adjustable front feet.

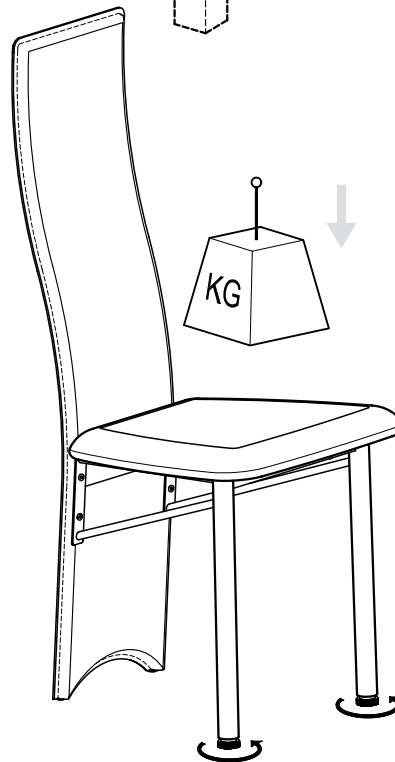

Assembly is complete.

If you need help or have damaged or missing parts, call the **Customer Helpline: 08456 400800**
Home Retail Group. 489-499 Avebury Boulevard. Saxon Gate West. Central Milton Keynes. MK9 2NW