

**Date:**  
9-Apr-10

**Prepared by:**  
CSH

**Checked by:**

**Article no.:**  
012168-xx-01-2436

**Description:**  
Bentwood dining chair

**Size:**  
W460XD560XH870mm

**Family Code:**

## Assembly instruction









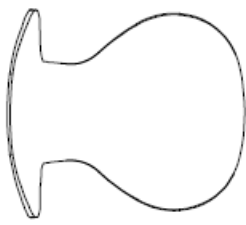

**Edition No.: 1**

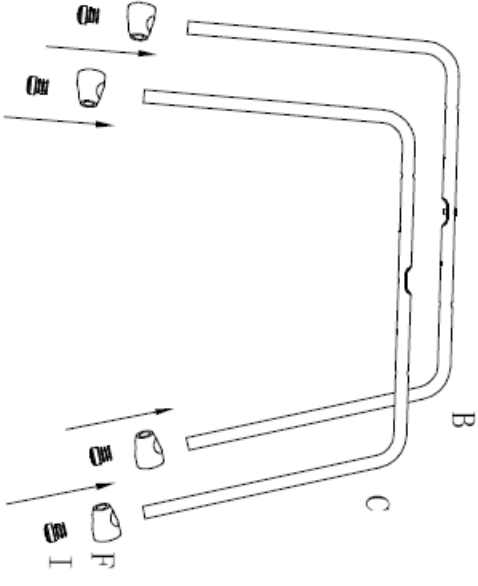
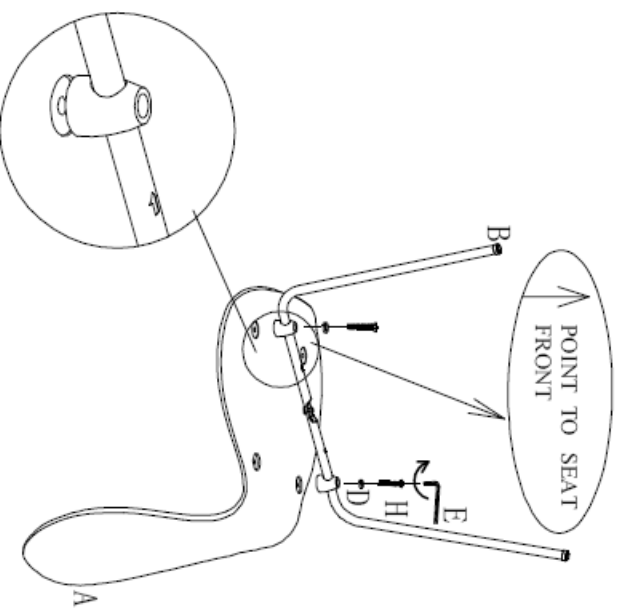
**(Date: 9/4/2010)**

### REVISION HISTORY

Revised Edition	Date DD/MM/YY	Change Details	Prepared By

## Assembly instruction

ASSEMBLY INSTRUCTION		CA001	
Ax1		Bx1	
1			
2	Cx1	 <p style="text-align: center;">POINT TO SEAT FRONT</p>	
Dx5		M6	
Ex1		4x64x25mm	
Fx4		5/8"	
Gx1		M6x15mm	
Hx4		M6x32mm	
Ix4		5/8"	
Jx4		φ17x6.5mm	

# ASSEMBLY INSTRUCTION

## CA001

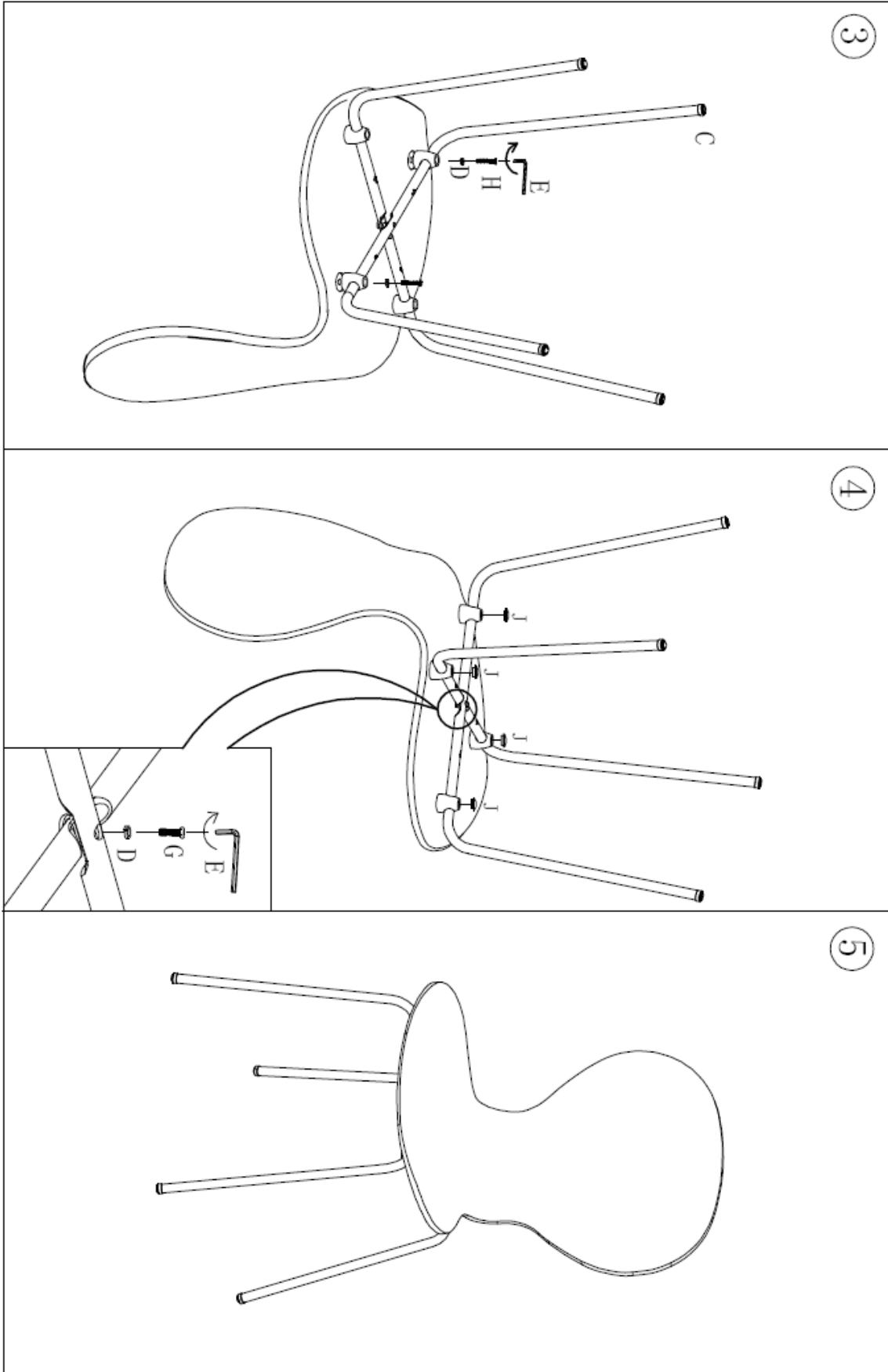

# Dining Chair

Assembly Instructions - Please keep for future reference

600/6039

600/6053

600/6022

600/6046

600/6077

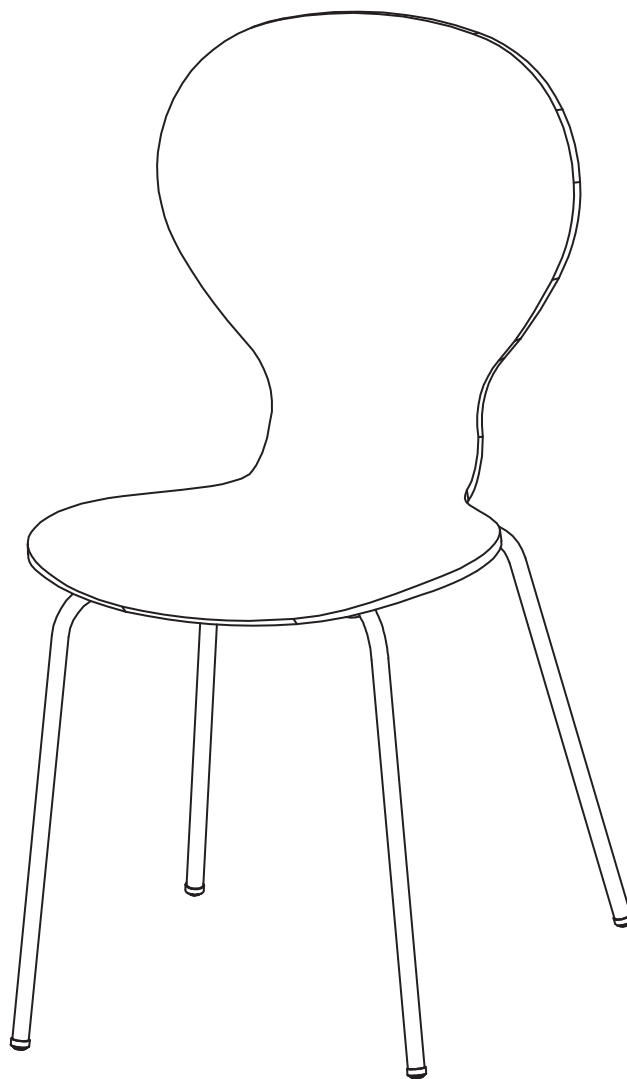

## Dimensions

Width - 46cm

Depth - 54cm

Height - 87cm

**Important** – Please read these instructions fully before starting assembly

If you need help or have damaged or missing parts, call the

Customer Helpline: 0845 640 0800



# Safety and Care Advice

## Important – Please read these instructions fully before starting assembly

- Check you have all the components and tools listed on pages 2 and 3.
- Remove all fittings from the plastic bags and separate them into their groups.
- Keep children and animals away from the work area, small parts could choke if swallowed.
- Make sure you have enough space to layout the parts before starting.

- Do not stand or put weight on the product during assembly, this could cause damage.
- Assemble the item as close to its final position (in the same room) as possible.
- Assemble on a soft level surface to avoid damaging the unit or your floor.
- Parts of the assembly will be easier with 2 people.



- We do not recommend the use of power drill/drivers **for inserting screws**, as this could damage the unit. Only use hand screwdrivers.
- Dispose of all packaging carefully and responsibly.

## Care and maintenance

- Only clean using a damp cloth and mild detergent, do not use bleach or abrasive cleaners.
- From time to time check that there are no loose screws on this unit.
- This product should not be discarded with household waste. Take to your local authority waste disposal centre.

# Components - Parts

Please check you have all the parts listed below

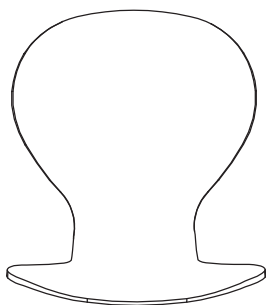

1 Seat (44 x 45 cm)

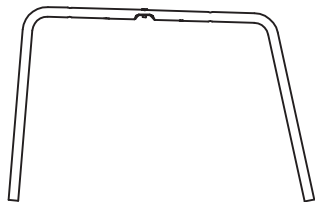

2 Top leg (64.5 x 43.3 cm)

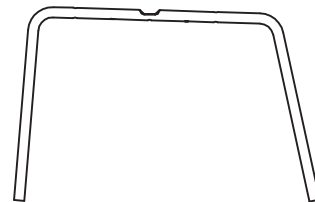







3 Bottom leg (64.5 x 43.3 cm)

# Components - Fittings

If you have damaged or missing components, call the Customer Helpline: 0845 640 0800

Please check you have all the fittings listed below

Note: The quantities below are the correct amount to complete the assembly. In some cases more fittings may be supplied than are required.

<p><b>A</b></p>  <p>Bolt x 4 (M6 x 32mm)</p>	<p><b>B</b></p>  <p>Bolt x 1 (M6 x 15mm)</p>	<p><b>C</b></p>  <p>Spring washer x 5 (M6)</p>
<p><b>D</b></p>  <p>White connector x 4 (5/8")</p>	<p><b>E</b></p>  <p>Plastic feet x 4</p>	<p><b>F</b></p>  <p>Rubber cap x 4</p>
<p><b>G</b></p>  <p>Allen key x 1</p>		

## Tools required



Ruler/tape measure

Ruler - Use this ruler to help correctly identify the screws

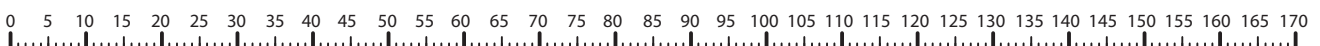

# Assembly Instructions

## Step 1

### Attaching connectors and feet to the legs.

Slide the white connectors **D** on legs **2** and **3**. Insert plastic feet **E** fully into the ends of legs **2** and **3**.

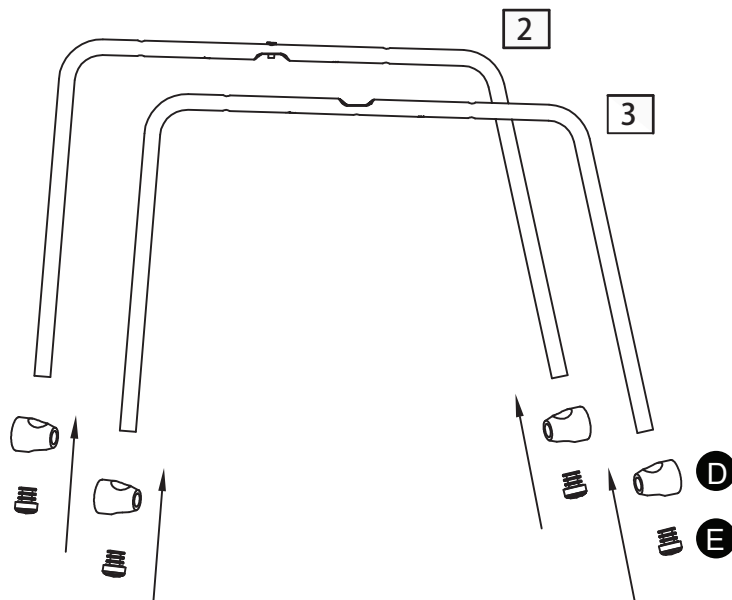

## Step 2

### Attaching leg **2** to chair seat.

Place the seat **1** on a covered table top. With the arrow marks on the legs pointing to seat front, move the connectors so that they are aligned to the holes of the leg and the screw threads on the seat. Assemble the legs to the chair seat with bolt **A** using allen key **G**.

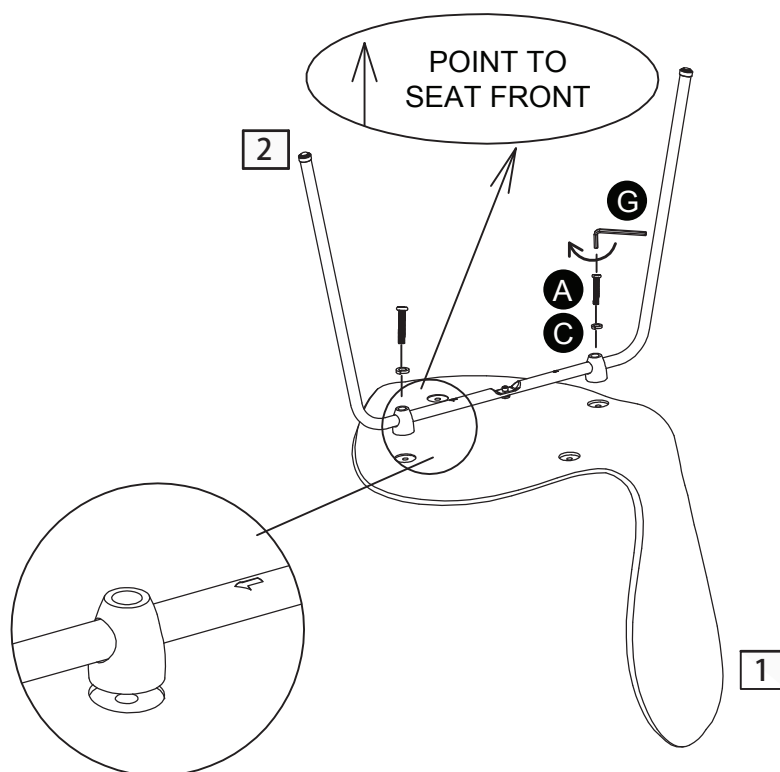

Continued on next page.



# Assembly Instructions

## Step3 - continued

### Attaching leg 3 to chair seat.

With the arrow marks on the legs pointing to seat front, move the connectors so that they are aligned to the holes of the leg and the holes on the seat. Assemble the legs to the chair seat with bolt **A** using allen key **G**.

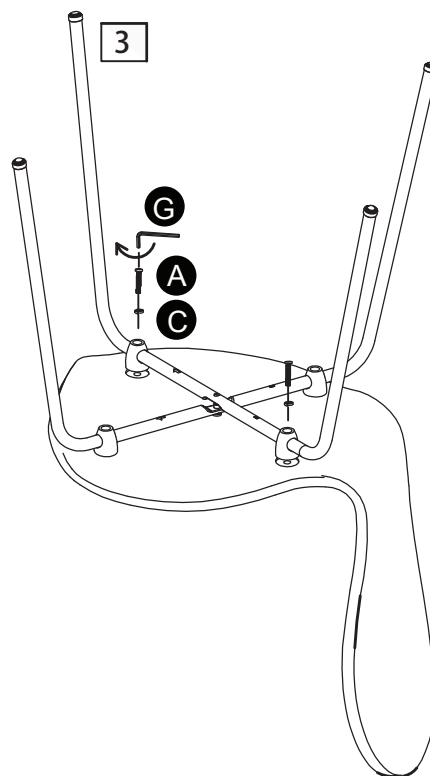

## Step4

### Final Assembly

Fasten bolt B with washer **C** where legs **2** and **3** overlap.

Cover the white connector **D** with Rubber cap **F**.

Turn the chair over carefully.

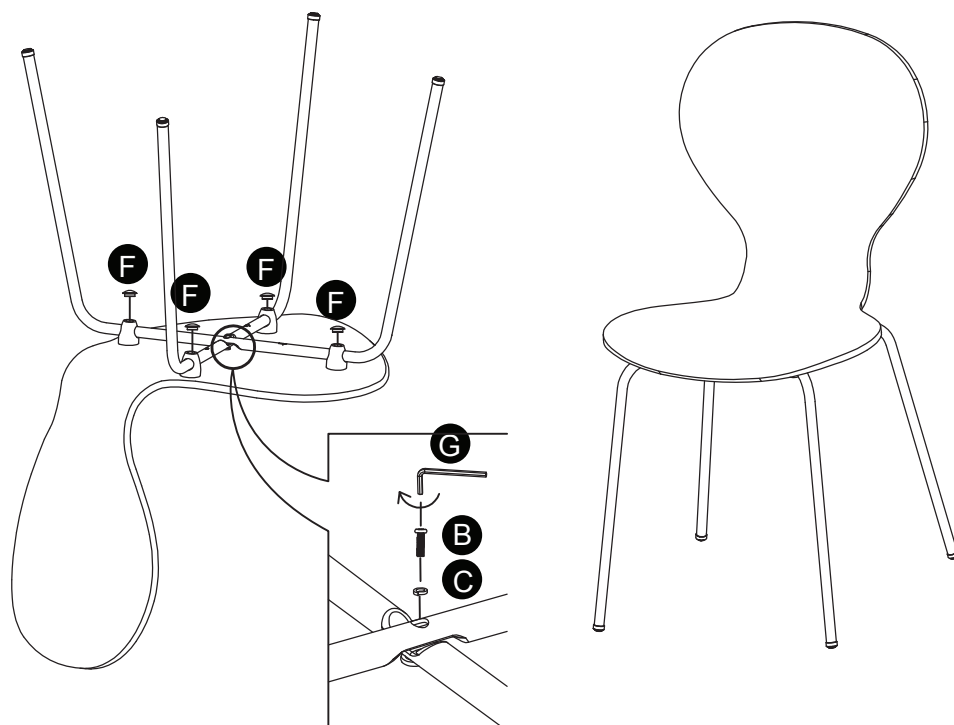

If you need help or have damaged or missing parts, call the Customer Helpline: 0845 640 0800  
Argos Ltd MK9 2NW