



Full Manufacturer's Guarantee

Our peace of mind pledge to you







*Thanks for purchasing
your new Rest Assured
bed or mattress.*

At Rest Assured we take pride in the quality and durability of our products. We know that reliability and peace of mind matter to our customers, that's why we offer a full 5 years manufacturer's guarantee on all of our mattresses, upholstered divan beds and headboards.

*Quality British Craftsmanship
at affordable prices*

All of our mattresses are handcrafted for your ultimate comfort. We use premium zoned pocket springs and carefully selected quality comfort fillings to deliver blissful comfort, night after night.

FIND OUT MORE AT
REST-ASSURED.CO.UK/GUARANTEES





Our peace of mind pledge to you

In a perfect world nothing goes wrong, but at Rest Assured we understand that sometimes things do.

In the unfortunate event that you do experience manufacturing issues with your new bed or mattress, whether that's through faulty materials or less than perfect workmanship, we promise to repair or replace any part, or all of the product that is defective. There are care and usage instructions and terms and conditions to this guarantee that we ask you to comply with. This information is all detailed in this booklet.

Wherever possible, replacement product will be like for like. However, if a particular style, material or model is no longer available we will substitute appropriately from our current range.

What is covered?

We will cover any manufacturing fault, faulty workmanship or materials on:

- **Mattresses**
- **Upholstered divan bases**
- **Upholstered headboards**

This guarantee only applies to product that has been purchased from an authorised Rest Assured retailer in the UK and Republic of Ireland. The guarantee is only intended for domestic products purchased and used for domestic purposes. The product must have been used and cared for in accordance with our manufacturer's guidelines and instructions and you'll find the details you need in this booklet under the Care and Usage Instructions section. The full terms and conditions of your guarantee are also listed in this booklet, please take the time to read through them.

Guarantee applicable on purchases made from 2nd April 2019.





I've got a problem, how do I make a claim?

To make a claim you will need to have your proof of purchase or delivery.

Any claim made under this guarantee must be made through the retailer from whom the bed was purchased. Please ensure you retain your receipt as proof of purchase. Any claim must be made no later than 5 years from the date of purchase.

Your legal rights as a consumer are not affected by this guarantee.





Care and usage instructions

Our beds and mattresses are designed and tested to the highest British standards, we want you to enjoy a great night's sleep, night after night. To help maintain the quality and comfort of your mattress and bed, we've put together these care instructions for you:

GETTING USED TO YOUR BED

Chances are that the springs and upholstery in your old bed were not what they used to be, so your new bed may seem a little strange at first. Please allow time for your body to adjust to your new bed and for the fillings to settle.

FILLING SETTLEMENT IS NORMAL

Due to modern day fillings being more sumptuous than their predecessors, settlement within your mattress should be expected and is perfectly normal.

Your new mattress is zoned to complement the human body and it is the underlying support system that ensures you are offered optimum support in the zoned areas. Some settlement in the filling layers is perfectly normal and there is no need for concern.

The main causes for settlement are attributed to:

- Extra pressure in areas where body weight is most pronounced.
- Body heat and moisture, which can escalate settlement and slow down the recovery process of the fillings.

Ensuring that your mattress is cared for properly may help to reduce settlement:

- Only use your mattress with a suitable base – one which will provide suitable support e.g. with slatted bed frames the slat widths should be 10cm and the gap between them no more than 7.5 cm
- If your mattress is double sided please turn and rotate it 'top-to-toe' regularly.
- If your mattress is single sided (indicated on the mattress label) rotate your mattress 'top-to-toe' so that settlement from body pressures are evenly distributed.
- Air your mattress daily by pulling bed covers back.

As with any soft furnishing product, your mattress will start to show settlement after several months of use. Whilst fillings may settle over time, the support system within your mattress will ensure that you receive many years of comfort from your mattress.



LET YOUR MATTRESS BREATHE

After its removal from the packaging, please leave your bed uncovered for a few hours to allow any condensation to escape. To avoid risk of suffocation, please ensure that the polythene bag is well out of reach of children. The polythene bag is recyclable.

TURN AND ROTATE YOUR MATTRESS REGULARLY

Unless you have bought a single sided 'No Turn' mattress, which will be indicated on the mattress label, it is important that you turn your double sided mattress over and rotate it from 'top-to-toe' once a week for the first two or three months and then monthly thereafter.

This will prolong the lifespan of your double sided mattress and ensure even settlement of the fillings. 'No Turn' mattresses should be rotated from 'top-to-toe' periodically to ensure even wear.

When turning or rotating your mattress please do not allow it to impact with or fall against the side of the bed as this may damage the spring system. We recommend having assistance when moving a mattress.

PROTECT YOUR MATTRESS

We recommend that you use a breathable mattress protector, which will protect it from coming into contact with body moisture or other liquids.

DO NOT USE DETERGENTS OR CHEMICAL CLEANERS

Using detergents or chemical cleaners on your mattress may damage the fabric and stitching. Unless otherwise stated your mattress cover is not removable or suitable for washing. If the mattress cover does state it is suitable for washing, please ensure you follow the instructions on the label attached to the product.

ROLLED MATTRESS RECOVERY

If you have purchased a rolled up mattress, please ensure that you unroll and place it on a bed in a warm room for 24 hours before use. After this time the mattress will fully regain its normal shape. Please note that recovery time will be faster when placed in a warm environment. The mattress cover should not be removed.

NEW MATTRESS SMELL

It's quite normal for new mattresses to have a slight odour when unpackaged. This is nothing to worry about and by airing the mattress you will find that any odours will pass.

DO NOT BEND OR ROLL YOUR MATTRESS

Your mattress may be delivered flat or rolled. Specialist equipment is used to roll a mattress. Please do not attempt to bend or re-roll your mattress yourself.

DO NOT OVERLOAD OR OVERFILL DRAWERS

If your bed has drawers, they have been designed to take lightweight items only. Excessive weight can cause distortion or damage to the drawers. Overfilling them may cause them to jam. Maximum weight: Mini drawers - 7kg. Standard drawers - 15kg. Our ottoman beds have a maximum fill weight of 40kg and this should be spread evenly.

UPHOLSTERY

Micro suede

Micro suede is a soft and durable fabric, making it an extremely popular choice. The fabric is water repellent and dirt resistant. However, should you need to remove any heavier stains, please use a neutral detergent, taking care not to over rub. Rinse with clean, lukewarm water.

Woven fabrics

Our luxurious woven fabrics have a soft, rich texture. These fabrics should be specialist cleaned only.

Faux leather

Faux leather has all the look of real leather, but is easy to care for. If you need to clean your faux leather headboard, simply wipe it with a clean, damp cloth.

Velour

A soft and silky fabric with fabulous plush texture. Take care when handling this tactile fabric as it can 'bruise'. You can gently brush it using a soft suede brush to remove any surface dust. Should you need to remove any stains or marks please contact a specialist cleaner.



Divan assembly instructions

You'll need: • Wooden/rubber mallet • Phillips/slotted/pozidriv screwdriver • Pliers • Scissors
To avoid the risk of injury, it is recommended that a minimum of two people assemble and install this product.

UNWRAPPING

Carefully remove any cardboard protectors and all packaging staples with pliers to avoid injury. Dispose of all polythene immediately to avoid the risk of suffocation to children. Where possible please recycle all packaging.

FITTINGS

Remove the fittings from the bags that are attached to the divan base.

ATTACHING CASTORS, LEGS, FEET AND GLIDES

Glides/Castors: (1) Push into the corner sockets and gently tap with a wooden/ rubber mallet until it is fully 'home'. Do not use a metal hammer or object as this may damage the castors or divan base.

Legs: (2) To affix legs, screw bolts into the threaded holes marked 'pierce here for fittings'.

Square feet: (3) To affix, screw the bolt into hole 1. Then screw the screw into hole 2. Make sure both screws have been fastened securely. Repeat on all 4 corners. Next screw the black glides into the remaining four holes in the divan base - two on each side.

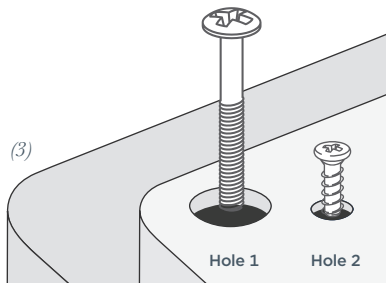
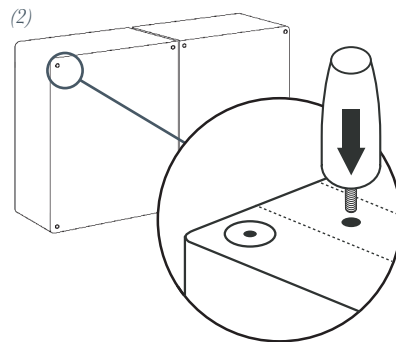
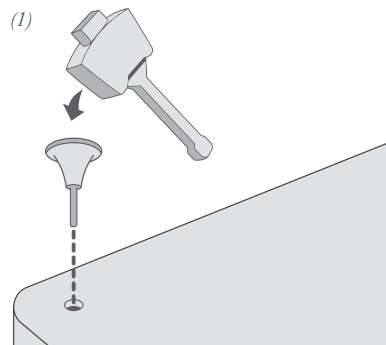

Call us on 01282 851 111

9





CONNECTING THE BASES

Stand the divan halves on their side and attach the U clips as indicated on the diagram below.

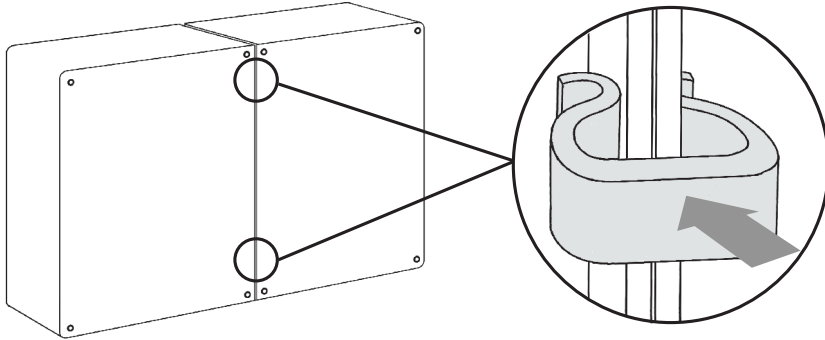

DRAWER STORAGE

To release the drawers, please cut the temporary restraining straps and trim off any excess.

Pulling the straps off may tear the fabric.

Ottoman instructions can be found on the following pages.

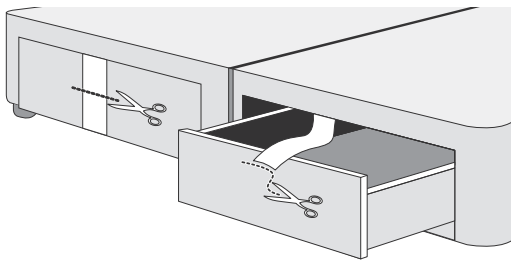

Do not overload the drawers.

- Mini drawers – max 7kg
- Standard drawers – max 15kg





ATTACHING A HEADBOARD:

First of all decide which end of the bed is to be used for a headboard, then use scissors to carefully pierce the fabric where the hole can be felt underneath the stickers.

Strutted headboards

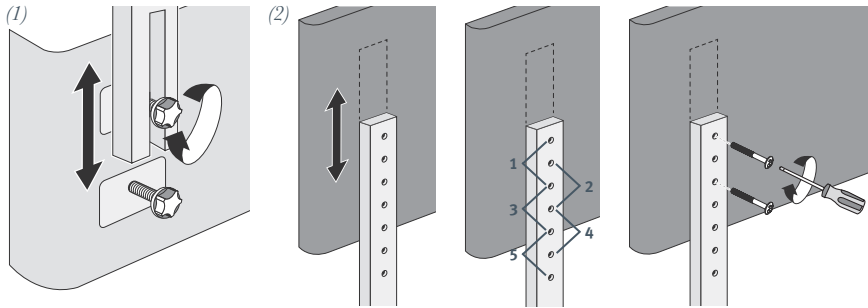

(1) Place the headboard bolt into the hole and fasten into place. Lower the headboard into position before fully tightening the bolt. (2) Note that headboard heights can be adjusted, by amending the position of the screws on the back of the board. There are 5 different positions in which you can adjust the height of your board to allow it to sit nicely above your mattress.

Full height headboards

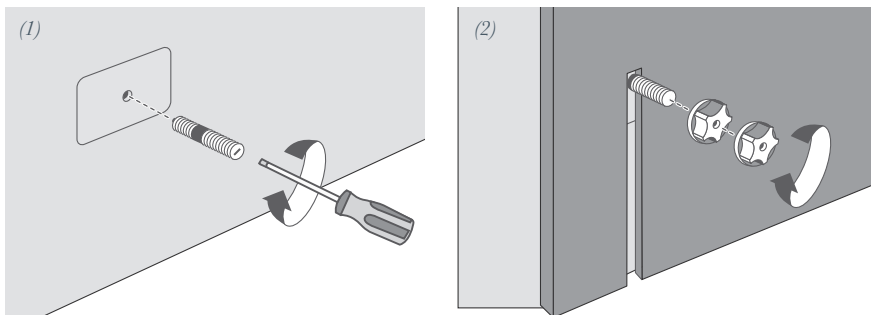

Using scissors, carefully pierce the fabric where the stickers mark the hole in the headboard. Line up the headboard hole with the divan hole. (1) Thread the headboard bolt through them both and tighten into position. If additional fittings have been supplied, please use these instead of the standard fittings issued with the Divan Base. Pierce the Divan with the bolts and screw into the base until the shorter thread is no longer visible. Position the headboard in place. (2) Place a single plastic cap on each of the bolts and tighten until headboard is secure.

Place a second plastic cap on each of the bolts to prevent them from catching*.

*The additional cap can also be used as a spacer between the Headboard and the Divan. This should only be used as a spacer if the Divan Drawer is restricted from opening by the Headboard.

Call us on 01282 851 111

11





Ottoman storage

The Ottoman storage solution helps you to maximise your bedroom space.

To get the best out of your new bed please follow these instructions at all times.

Cutting the Ottoman strap will cause the Ottoman to open immediately.
Please ensure you follow the instructions below.



UNWRAPPING THE OTTOMAN BASE

1. Remove all the polythene and corner card packaging. To avoid risk of suffocation, please ensure that the polythene bag is well out of reach of children. The polythene bag is recyclable.
2. Remove any proud packaging staples.
3. Stand the divan vertically on the short side.
4. Before cutting the strap, please note that the lid will open automatically. Allow sufficient space for the lid to open.
5. Cut the strapping.
6. Remove castor pack from inside the Ottoman ensuring all packaging staples are removed and insert the castors/glides/legs.
7. Attach both bases together. See diagram and instructions on next page.
8. Place your mattress on top of the bed.

- Never operate the recliner mechanism without a mattress on the divan base.
- Never allow children or pets to play on or inside the Ottoman divan base.
- Stand clear when opening or closing the Ottoman divan base.
- Ensure bed linen does not get caught within the recliner mechanisms.
- Close the Ottoman divan base by pushing down with both hands centrally on the mattress.
- Do not operate the mechanism while the bed is being used.
- Maximum loading weight is 40kg evenly distributed.





Half ottoman assembly instructions

These assembly instructions apply to the Ottoman divan base only. Please disregard the plastic clip in the standard Divan half fittings pack. Please use the metal clips to join the Divan and Ottoman halves together.

STEP 1

(1) Position the two divan halves on the floor together.

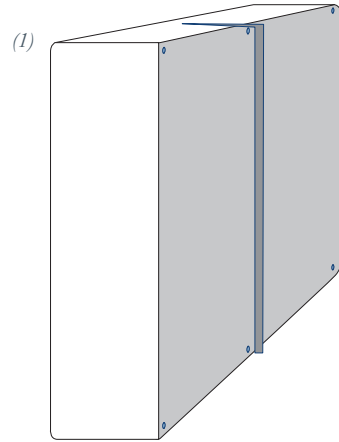

STEP 2

(2) Ensure the metal clips are positioned in the recess of the black undercover.

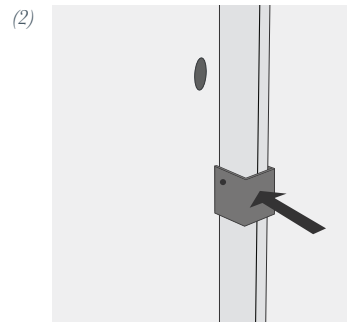

STEP 3

(3) Use screws provided to fix the clip to the divan.

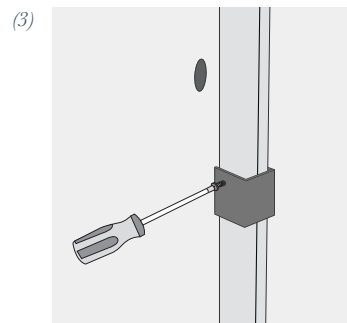



Full ottoman assembly instructions

You'll need: • 2x Medium/Large Posi and/or Flat-head screwdriver or similar
• Wooden/rubber mallet • Large bradawl or similar • Scissors

To avoid the risk of injury, it is recommended that a minimum of two people assemble and install this product.

CASTOR/GLIDE CONNECTION

1. Remove the fittings bag/instructions, and cut the lid ties.
Care should be taken as the lid will try to open.
2. Close the lid and turn the base on to its side. Locate and hammer home the 4 castors/glides into the corner sockets.
3. Turn the base so it is sitting on the castors/glides with the lid open.
4. Repeat for the second base.
5. Position the bases together.

BASE CONNECTION

1. Identify the 2 drilled connecting holes on the outer sides of each base unit (**blue arrows**) and fit the beige plastic hole plugs. Remove the 'Pierce Here' labels from the outside of the base units.
2. Identify the 2 drilled connecting holes on the inner sides of each base unit (**red arrows**) identified on the outside of the base by 'Pierce Here' labels which should be removed. Using the large bradawl, pierce the fabric and make a hole large enough for the 'female' connector in all 4 aligned holes.
3. Push both base units together and align.

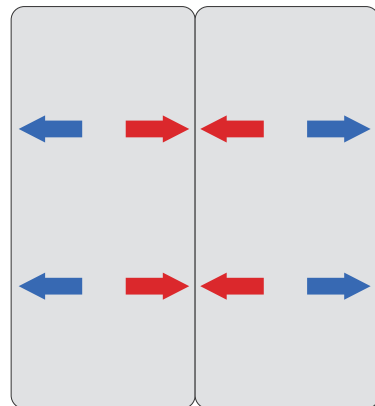



4. After applying a metal washer, insert the 'female connector' from the inside of one of the base units. Also using a metal washer, insert the 'male connector' from the inside of the other base unit. Note: This can be quite fiddly; please persevere!

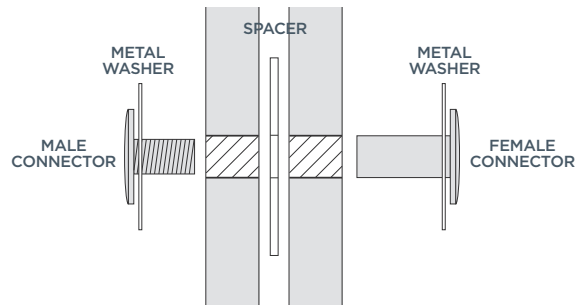

5. Screw the male and female connectors together.
6. Repeat for the 2nd connecting hole.

LID CONNECTION

1. Identify the 2 drilled connecting holes on the front, inner sides of each lid (green arrows), identified with a 'Pierce Here' label. Using the large bradawl, pierce the fabric and make a hole large enough for the 'female' connector in both holes.
2. After applying a metal washer, insert the 'female connector' from the inside of one of the lids. Also using a metal washer, insert the 'male connector' from the inside of the other lid.
3. Screw the male and female connectors together.

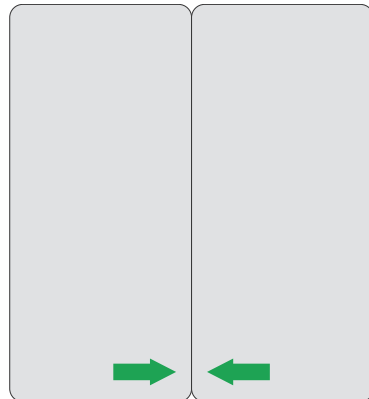

It may be necessary to include one or both plastic spacer washers between the lids to allow alignment adjustment due to the potential irregularities of floor surfaces.

HEADBOARD CONNECTION

1. The head end of each base unit has 4x threaded inserts (only 2 may be required). Identify which you need to fit your headboard and using the large bradawl, pierce the fabric ('Pierce Here' labels are positioned on the outside of the cover). Insert the headboard bolt and repeat for the other locations.

The mattress can now be placed on the ottoman base.





WIN A MATTRESS OF YOUR CHOICE

Tell us what you think about your new mattress or bed and you could win a mattress for another bedroom.

We always welcome your comments on our products and to thank you for taking the time to send us a review, we'll enter you in to our draw to win another Rest Assured mattress. **All you need to do is:**

1. Visit www.rest-assured.co.uk and click on 'reviews'
2. Click on 'Leave a review'
3. Search for your product and fill in the required information
4. Submit your review to be automatically entered into the draw
5. Don't forget to leave a review with your retailer too, this really helps other people who are looking to buy

Mattress to be selected from our current range up to a maximum retail value of £895. For full terms and conditions visit: www.rest-assured.co.uk/terms-and-conditions







BED MAKING EXPERTISE

HANDED DOWN SINCE 1898

At Rest Assured we know a thing or two about handcrafting luxuriously comfortable mattresses and beds at reassuringly affordable prices. Over 120 years of bed making expertise has been handed down through the generations, combining timeless design with tried and tested bed making techniques.



All of our mattresses and upholstered divan bases and headboards are designed and handmade in our home in Lancashire.



We're proud to be an approved member of the British Furniture Manufacturers (BFM) Trade Association – championing British manufacturing.



Every product type is tested for quality, safety and durability in our SATRA accredited test lab, ensuring we meet and exceed stringent UK safety standards.



We're dedicated to having a positive impact on our planet right across our business and this commitment has been recognised by a number of independent bodies and awards.



The mark of responsible forestry



We're committed to creating a greener environment through our business practices and by sourcing materials from sustainable areas. That's why we're members of the Forest Stewardship Council® (FSC®C104461) and the Furniture Industry Sustainability Programme.

Terms & Conditions



Terms and Conditions of your Full Manufacturer's Guarantee.

If you wish to make a claim under the guarantee please check the conditions below and any in this booklet relating to your specific product. You must be able to provide proof of purchase/delivery to be able to register a claim. Your purchase must have been made through an authorised retailer of Rest Assured products within the UK and Republic of Ireland.

1. Your mattress may be delivered flat or rolled. Specialist equipment is used to roll a mattress. Please do not attempt to bend or re-roll your mattress yourself. This applies on delivery and should you need to move the mattress from room to room or house to house.
2. Please do not attempt to modify, alter or adapt your mattress, bed or headboard as this will invalidate your guarantee.
3. Your mattress must have been used in accordance with the care instructions and turned and rotated 'top-to-toe' if double sided or rotated 'top-to-toe' if single sided to help with settling the cushioning layers.
4. A single sided or 'no turn' mattress is usually indicated on the label. Single sided mattresses should only ever be used on the sleeping surface - label side up.
5. We are unable to accept items that are soiled or unhygienic.
6. We recommend that you use a breathable mattress protector from new to maintain your mattress.
7. The mattress should not be used without bed linen.
8. The mattress must be used with a suitable base - one which will provide suitable support e.g. with slatted bed frames the slat widths should be 10cm and the gap between them no more than 7.5 cm.
9. The weight tolerance of 7kg for the small drawers, 15kg for the standard drawer and 40kg

for ottoman beds has not been exceeded. Overloading the drawers can cause distortion or damage and may also cause them to jam. Ensure weight is evenly distributed.

10. We will be unable to accept a claim if the product has been subjected to unfair wear and tear or misuse.
11. This guarantee does not cover accidental damage and only covers defects in manufacture, materials or workmanship.
12. We may choose to instruct an independent third party specialist to carry out an in-home assessment of your product and claim to assist in our decision making.
13. This guarantee only applies to Rest Assured products that have been purchased from an authorised retailer in the UK and Republic of Ireland.
14. This guarantee only applies to domestic products that have been purchased and used in a domestic setting. This guarantee does not apply to commercial products or premises.
15. This guarantee can't be transferred to anyone else if you decide to sell your Rest Assured product within the guarantee period.
16. This guarantee is a manufacturer's guarantee and is limited to repair or replacement at our discretion. You may have additional rights under the Consumer Rights Act 2015 with your retailer. It is usual for your retailer to deal with your claim in at least the first year after purchase, so always check with them first.
17. This guarantee does not affect your consumer rights.

Rest Assured
Long Ing Business Park
Long Ing Lane
Barnoldswick
Lancashire
BB18 6BJ

Enquiries@rest-assured.co.uk



REST ASSURED

BEAUTIFUL BEDS SINCE 1898



Rest Assured Beds

Don't forget to give us a Like on Facebook to keep up to date with our latest products, promotions and news.

Rest Assured, Long Ing Business Park, Barnoldswick. Lancashire BB18 6BJ

Tel: 01282 851111 **Fax:** 01282 850107 **Email:** enquiries@rest-assured.co.uk

rest-assured.co.uk



R770100

February 2019