

# HYGENA FARRELL CHAIR

Assembly Instructions - Please keep for future reference

531/6689

**hygena**



## Dimensions

Width - 65cm

Depth - 64cm

Height - 116/126cm

**Important – Please read these instructions fully before starting assembly**

If you need help or have damaged or missing parts, call the Argos Aftersales Helpline 0345 640 0800



## Safety and Care Advice

### Important – Please read these instructions fully before starting assembly

- Check you have all the components and tools listed on pages 2 and 3.
- Remove all fittings from the plastic bags and separate them into their groups.
- Keep children and animals away from the work area, small parts could choke if swallowed.
- Make sure you have enough space to layout the parts before starting.

- Do not stand or put weight on the product during assembly, this could cause damage.
- Assemble the item as close to its final position (in the same room) as possible.
- Assemble on a soft level surface to avoid damaging the unit or your floor.
- Parts of the assembly will be easier with 2 people.



- We do not recommend the use of power drill/drivers **for inserting screws**, as this could damage the unit. Only use hand screwdrivers.
- Dispose of all packaging carefully and responsibly.

### Care and maintenance

- From time to time check that there are no loose screws on this unit.
- To avoid any risk of suffocation to animals or children dispose of the plastic bags immediately .
- As with all surfaces clean with a damp cloth and mild detergent, do not use bleach or abrasive products.
- This product should not be discarded with household waste. Take to your local authority waste disposal centre.

### Safety during use

- Do not stand on this chair. Do not use this chair as a step ladder .
- Use this product only for seating one person at a time.
- Do not use this chair unless all bolts,screws and knobs are firmly secured.
- At least every 4 months, check all bolts, screws and knobs , to be sure they are tight .
- If parts are missing, broken or damaged or worn, stop use of this product until repairs are made & using factory authorized parts .
- Failure to follow these warnings could result in serious injury.

**Note:** if required the next page can be cut out and used as reference throughout the assembly. Keep this page with these instructions for future reference.

# Components - Parts

Please check you have all the parts listed below

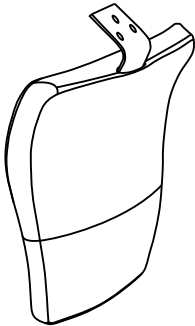

**1** Backrest x1(76x49cm)



**2** Seat x 1(49x53cm)

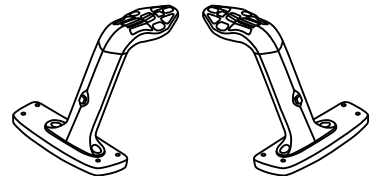

**3** Left armrest x1 & Right armrest x 1

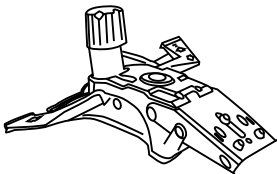

**4** Seat plate x 1



**5** Gas lift x 1(100mm)

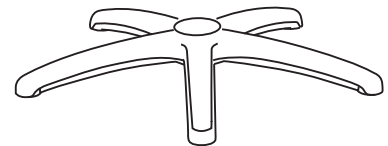

**6** Base x 1(350mm)



**7** Castors x 5 (R50mm)

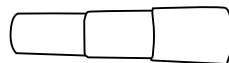



**8** Gas lift cover x 1

# Components - Fittings

If you have damaged or missing components, call the Argos Aftersales Helpline 0345 640 0800

Please check you have all the fittings listed below.

**Note:** The quantities below are the correct amount to complete the assembly.  
In some cases more fittings may be supplied than are required.

<b>A</b>  20mm Bolts x 4	<b>B</b>  25mm Bolts x 6	<b>C</b>  20mm Bolts x 3

## Tools required



M6 Allen key (supplied)

Ruler - Use this ruler to help correctly identify the screws

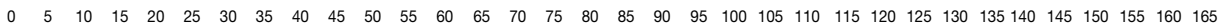

# Assembly Instructions

## Step 1

### Fitting the base

**a:** Push all the five castors **7** into the underside of the base **6**.

**NOTE:** Ensure all the castors are firmly located on the base.

Insert the gas lift **5** into the base **6**. Put the gas lift cover **8** onto the gas lift **5**.

**NOTE:** Ensure the gas lift is fully inserted and well fitted.

**a:**

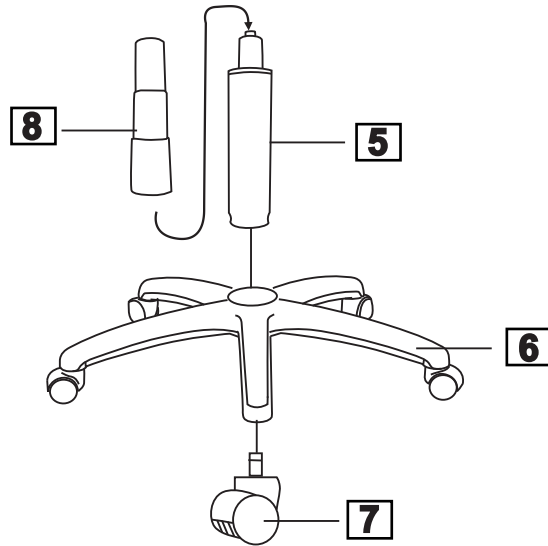

## Step 2

### Fitting the Armrests

Use bolts **B** to fix the left armrest and right armrest **3** onto the seat **2**.

**NOTE:** It would be useful to ask someone to help you at this stage.

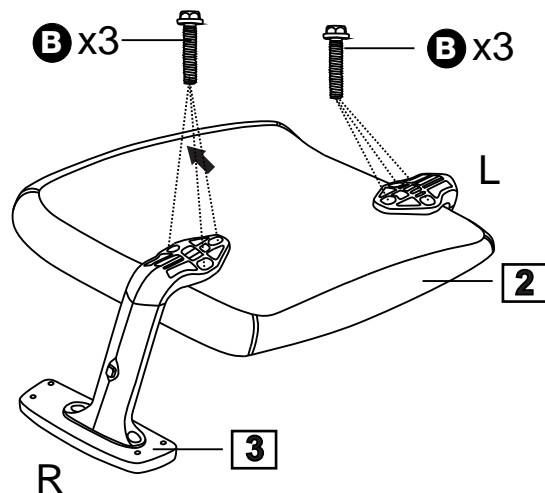

# Assembly Instructions

## Step 3

### Fitting the Seat Cushion

Use bolts **A** to fix the seat plate **4** onto the seat **2**. Ensure the support is fitted to the seat with correct orientation.

**NOTE:** It would be useful to ask someone to help you at this stage.

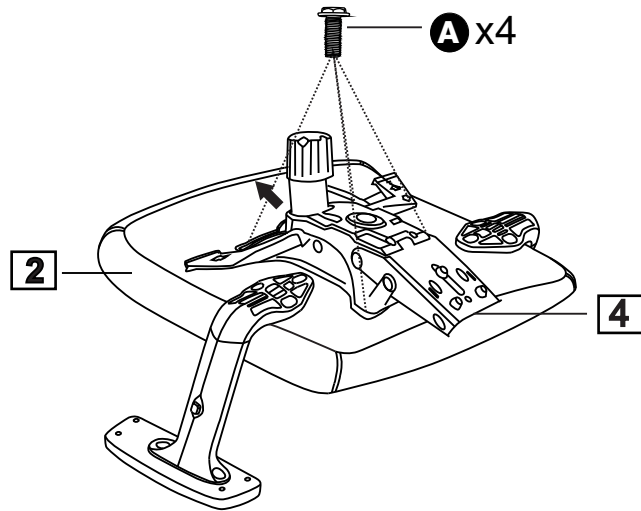

## Step 4

### Fitting the Backrest

Use bolts **C** to fix the backrest **1** onto the seat plate **4**.

**NOTE:** It would be useful to ask someone to help you at this stage.

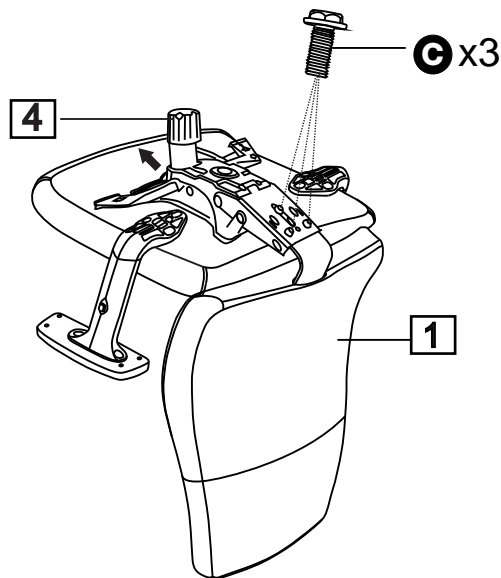

# Assembly Instructions

## Step 5

### Fitting the Unit

Carefully locate the seat **2** onto the base unit.

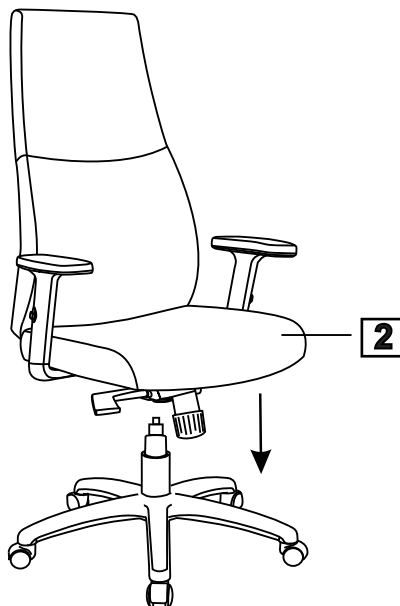

## Step 6

### Finishing the Unit

Carefully place the unit in the desired location.

**Assembly is complete.**



If you need help or have damaged or missing parts, call the Argos Aftersales Helpline 0345 640 0800  
489-499 Avebury Boulevard Milton Keynes MK9 2NW, Argos Limited