

# PENTON - Corner TV Unit

**Assembly Instructions** - Please keep for future reference

462/6198

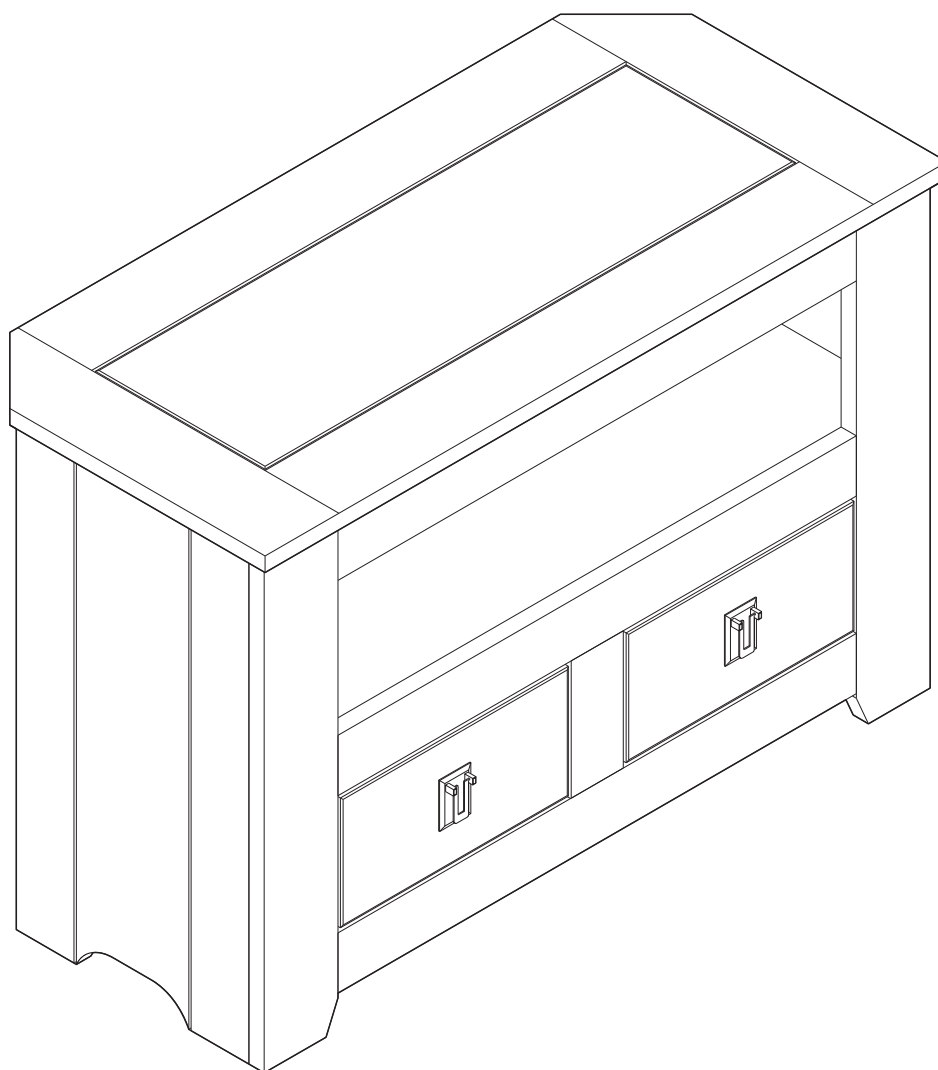

## Dimensions

Width - 85cm

Depth - 40cm

Height - 57cm

**Important** – Please read these instructions fully before starting assembly

If you need help or have damaged or missing parts, call the **Customer Helpline: 03456 400 800**



# Safety and Care Advice

**Important** – Please read these instructions fully before starting assembly

- Check you have all the components and tools listed on pages 2 and 3.
- Remove all fittings from the plastic bags and separate them into their groups.
- Keep children and animals away from the work area, small parts could choke if swallowed.
- Make sure you have enough space to layout the parts before starting.
- Do not stand or put weight on the product, this could cause damage.
- Assemble the item as close to its final position (in the same room) as possible.
- Assemble on a soft level surface to avoid damaging the unit or your floor.

- This product has been produced from natural timber; you may notice some variation in the grain and colour of different component parts which is normal for furniture produced using natural wood and is not the result of any manufacturing fault.
- The product has been treated with a wax and oil finish to prevent dirt ingress and preserve moisture.
- On unpacking the furniture you may notice an odour due to this treatment; this will disappear once the furniture is unpacked and assembled after a period of time.
- This process may leave some staining on the packaging material; please take care to ensure this does not transfer to clothing or carpeted surfaces during assembly.

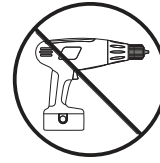

as this could damage the unit. Only use hand screwdrivers.

- We do not recommend the use of power drill/drivers **for inserting screws**,

- Parts of the assembly will be easier with 2 people.
- Dispose of all packaging carefully and responsibly.

## Care and maintenance

- Use an appropriate furniture polish for natural wood furniture and a dry cloth to clean the product.
- Avoid placing the furniture in direct sunlight as this will cause the timber to prematurely age.
- From time to time check that there are no loose screws on this unit.
- This product should not be discarded with household waste. Take to your local authority waste disposal centre.

**Note:** If required the next page can be cut out and used as reference throughout the assembly. Keep this page with these instructions for future reference.

# Components - Panels

Please check you have all the panels listed below

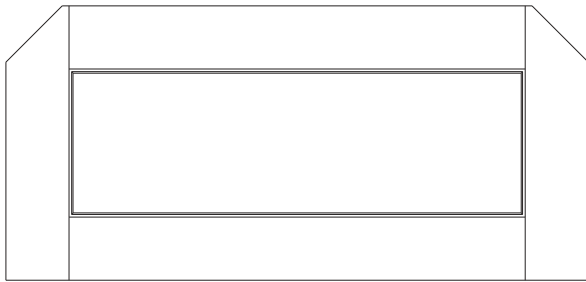

**1** Top panel (85 x 40cm)

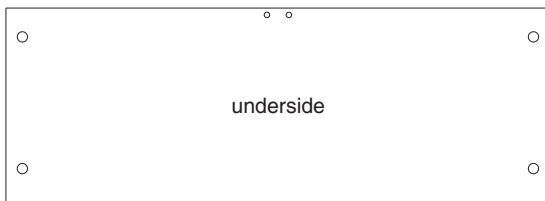

**2** Base panel (79.4 x 28.4cm)

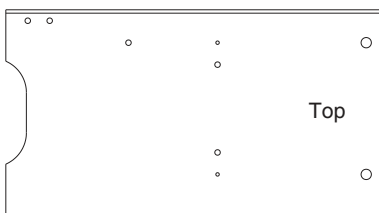

**3** Right side panel (55 x 30cm)

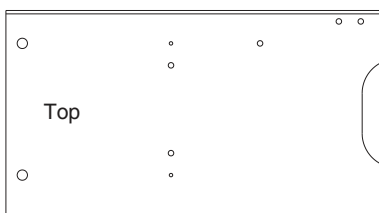

**4** Left side panel (55 x 30cm)

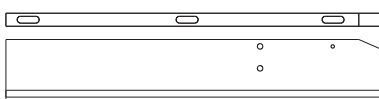

**5** Right front frame (55 x 9.2cm)

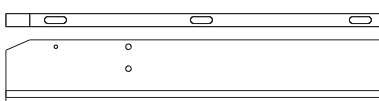

**6** Left front frame (55 x 9.2cm)



**7** Back panel (81.2 x 27cm)



**8** Top front frame (68.6 x 6.5cm)

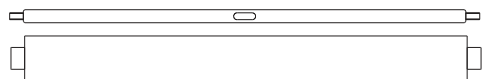

**9** Bottom front frame x 2 (68.6 x 6.5cm)



**10** Cross rail (79.4 x 6.5cm)

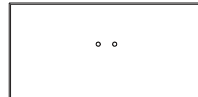

**11** Drawer front x 2 (28.4 x 14cm)

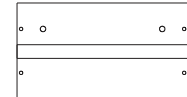

**12** Drawer sides x 4 (25 x 14cm)



**13** Drawer back x 2 (26 x 14cm)



**14** Drawer bottom x 2 (27 x 23.6cm)



**15** Side drawer runner x 2 (28.4 x 8cm)



**16** Middle drawer runner (26.4 x 8cm)

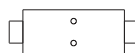

**17** Vertical frame (18.8 x 6.5cm)

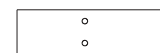

**18** Back column (22 x 6.5cm)









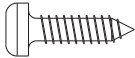

**19** Block x 4 (10 x 2cm)

# Components - Fittings

If you have damaged or missing components, call the **Customer Helpline: 03456 400 800**

Please check you have all the fittings listed below

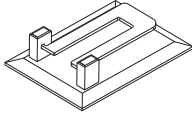
**Note:** The quantities below are the correct amount to complete the assembly. In some cases more fittings may be supplied than are required.

<p><b>A</b> </p> <p>Wooden dowel x 34</p>	<p><b>B</b> </p> <p>14mm Screw x 2</p>	<p><b>C</b> </p> <p>30mm Screw x 16</p>
<p><b>D</b> </p> <p>35mm Screw x 24</p>	<p><b>E</b> </p> <p>22mm Bolt x 4</p>	<p><b>F</b> </p> <p>Metal dowel x 8</p>
<p><b>G</b> </p> <p>Locking nut x 8</p>	<p><b>H</b> </p> <p>Drawer handle x 2</p>	<p><b>I</b> </p> <p>Nail x 16</p>

## Tools required



Phillips screwdriver  
(small & medium)

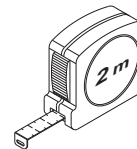

Ruler/tape  
measure



Small  
hammer

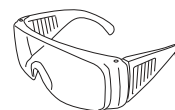

Eye protection  
(when using a  
hammer or glue)

**Ruler** - Use this ruler to help correctly identify the screws



# Assembly Instructions

## Step 1

**Fixing right front frame to the right side panel**  
(Two people required for an easier assembly).

**a:** Insert right side panel **3** into right front frame **5** through joints.



**Note:**

Before fixing blocks **19** into place it is important to ensure that the slot and groove of parts **3** and **5** are fully pushed together and lined up correctly at the top and bottom.

**b:** Place blocks **19** between the two marks as shown. First fix to the side panel using screws **D**.

**c:** Fix front frame through blocks **19** using screws **D**.

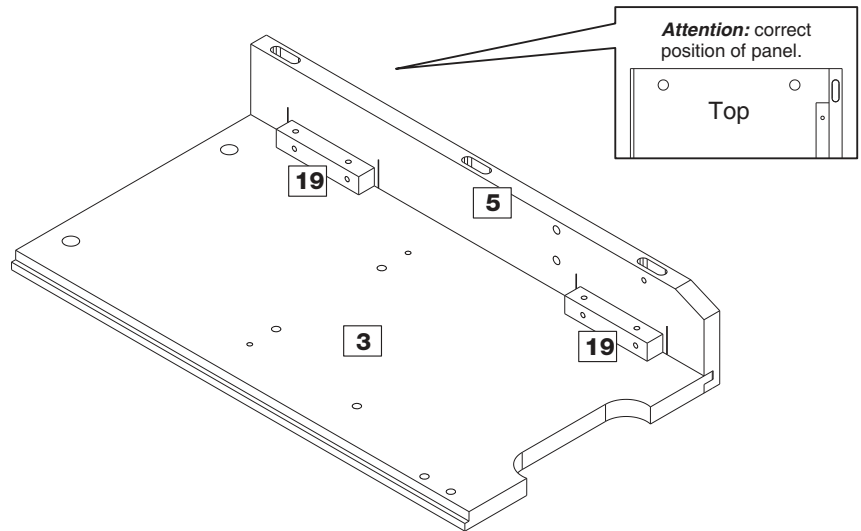
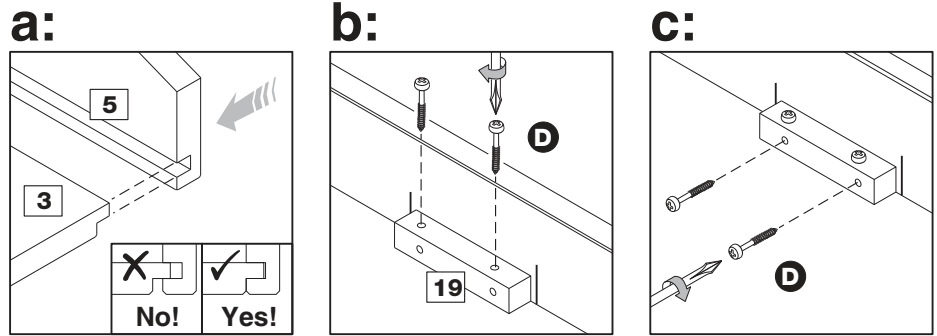

## Step 2

**Fixing left front frame to the left side panel**  
(Two people required for an easier assembly).

**a:** Insert left side panel **4** into left front frame **6** through joints.



**Note:**

Before fixing blocks **19** into place it is important to ensure that the slot and groove of parts **4** and **6** are fully pushed together and lined up correctly at the top and bottom.

**b:** Place blocks **19** between the two marks as shown. First fix to the side panel using screws **D**.

**c:** Fix front frame through blocks **19** using screws **D**.

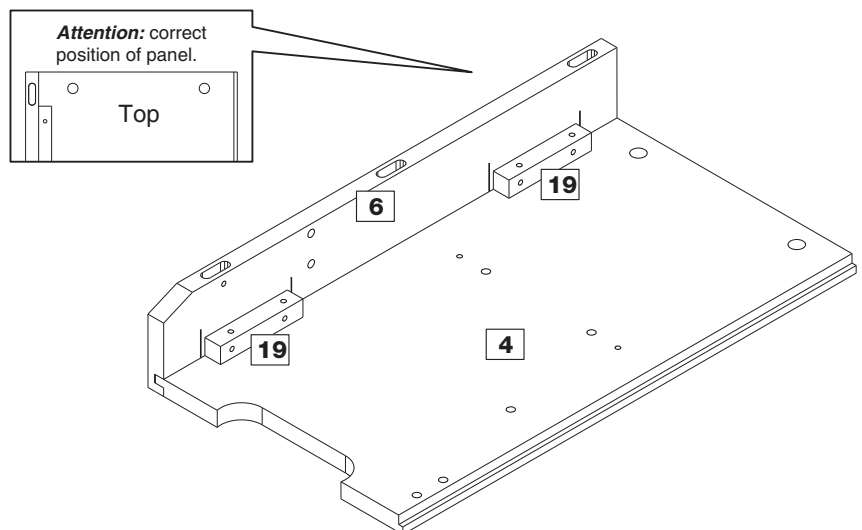
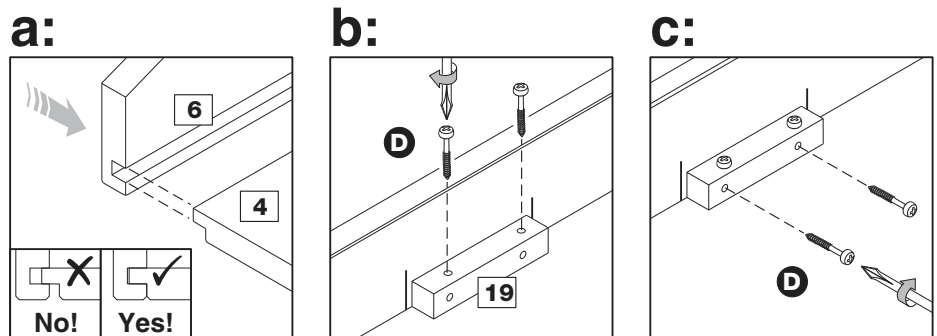

# Assembly Instructions

## Step 3

Insert dowels **A** into the indicated parts.

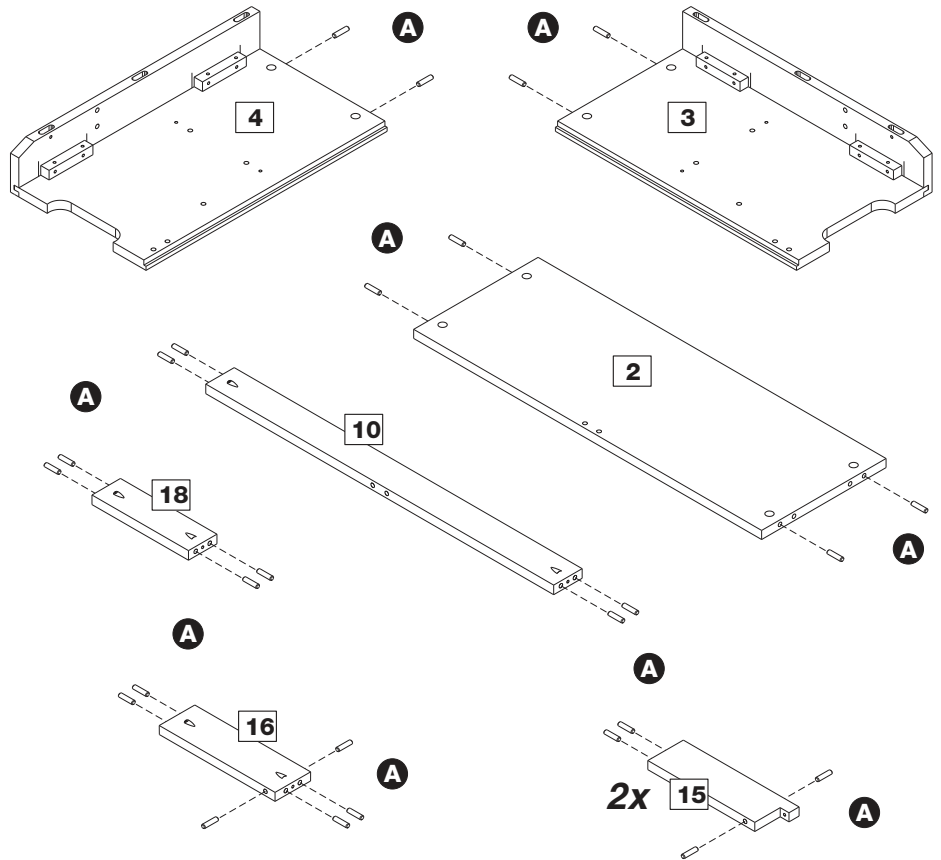

## Step 4

### Fitting Metal dowels.

Screw metal dowels **F** into top panel **1** and side panels **3** and **4**.



**Note:** Insert metal dowels as far as shown.

**Do not over tighten.**

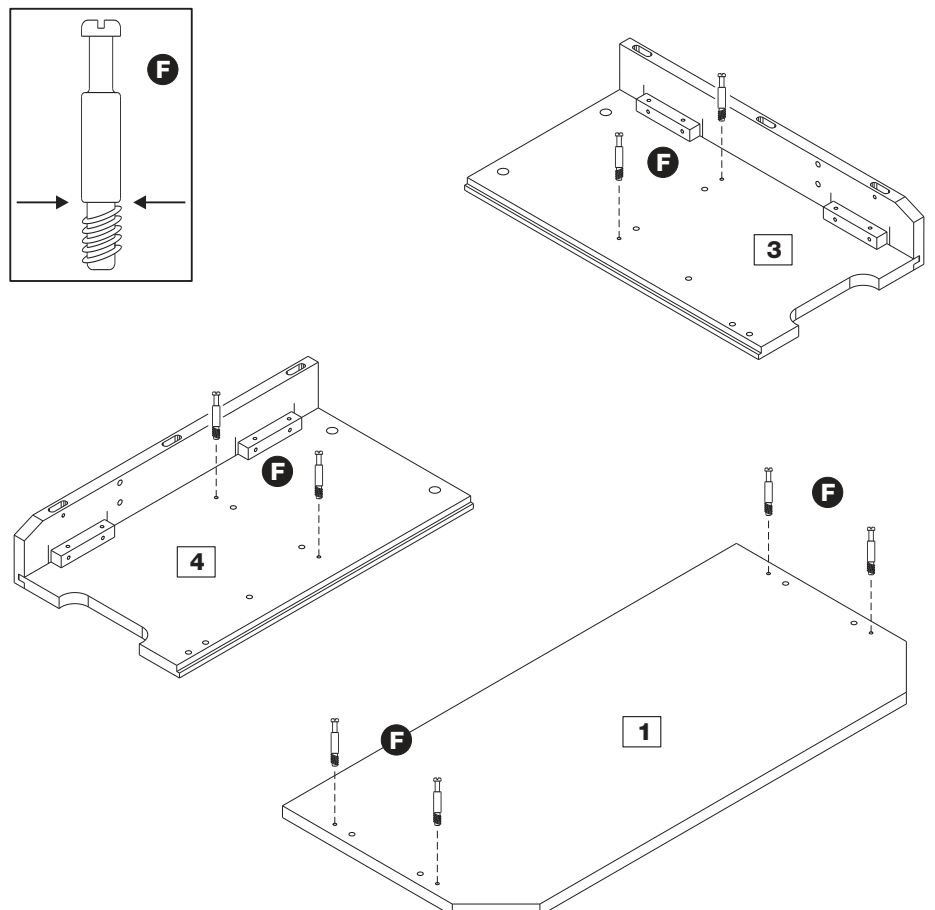

# Assembly Instructions

## Step 5

### Fixing side drawer runners.

**a:** Fit side drawer runner **15** to the right side panel. Fit and push dowels into the front frame first.

**b:** Attach side drawer runner using screw **D**.

Repeat step 5 for the left side panel and side drawer runner.

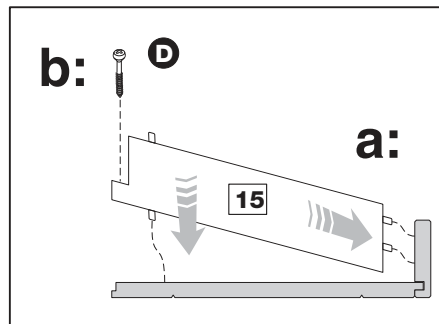
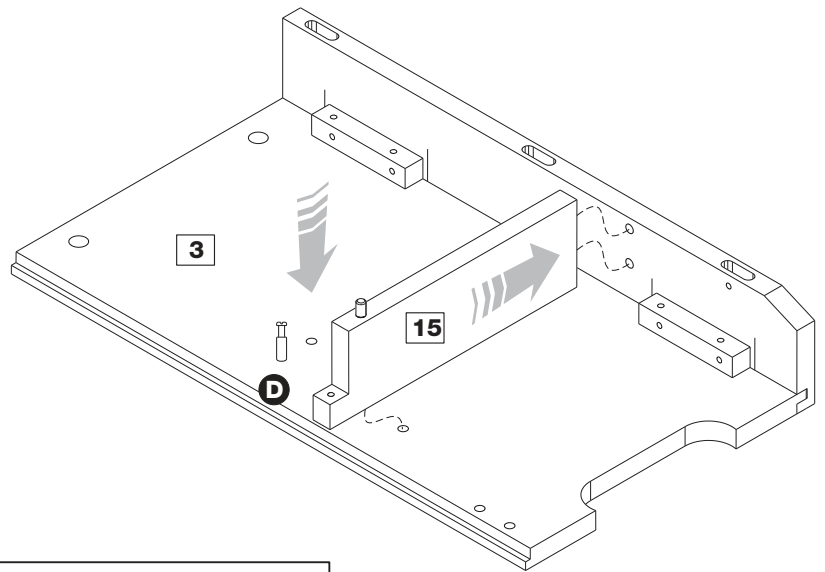

## Step 6

### Assembling parts.

Put parts **9** and **17** together as shown in the diagram.

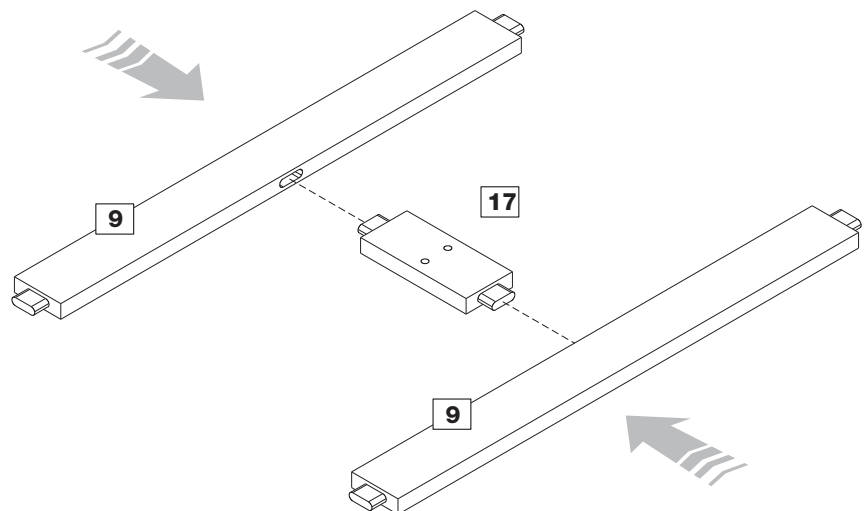

# Assembly Instructions

## Step 7

Insert the assembled frame and top front frame **8** into the holes on left side panel **4**.

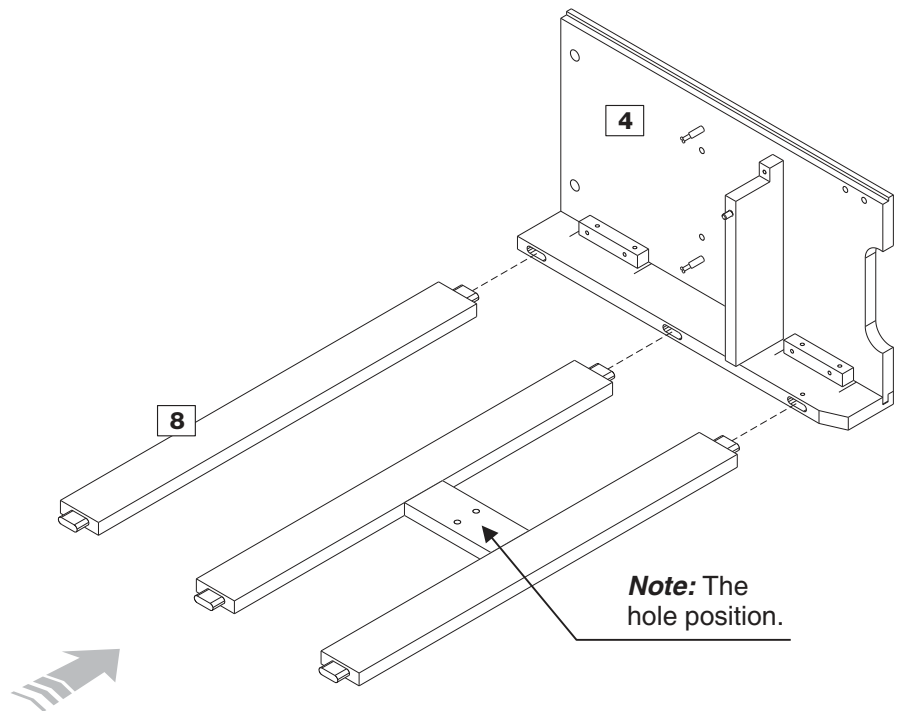

## Step 8

### Fixing base panel.

With help, fit base panel **2** to the left side panel.



**Note:** The hole position on the base panel.

Insert 2 locking nuts **G** into base panel where shown.

Use a screwdriver to turn locking nuts **G** clockwise to lock.

**Do not over tighten.**

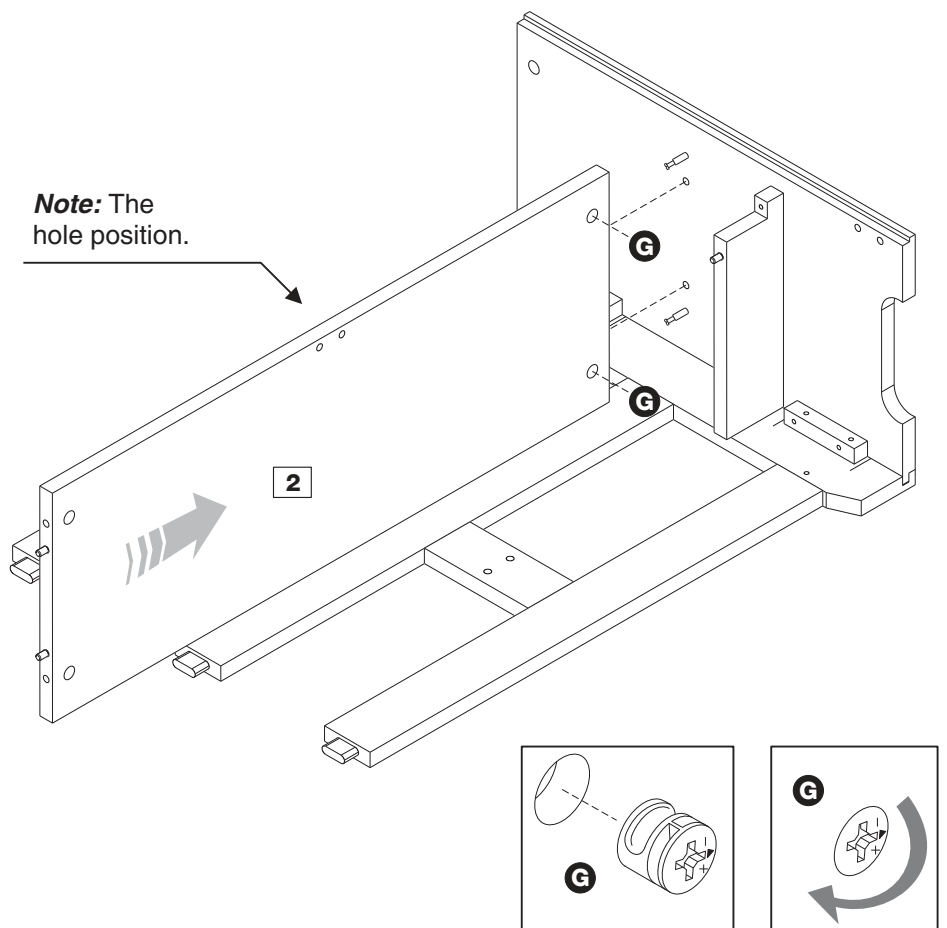



# Assembly Instructions

## Step 9

### Fixing middle drawer runner.

Fit middle drawer runner **16** to the vertical frame then fix using screw **D**.



**Attention:** Make sure middle drawer runner is positioned as shown in the diagram prior to fixing.

### Attention:

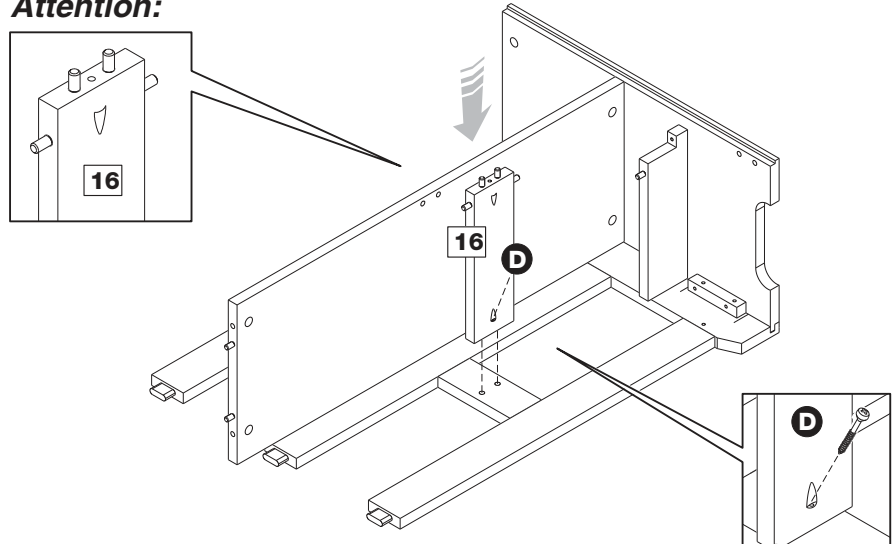

## Step 10

### Fixing back column.

Fit back column **18** to the base panel **2** and middle drawer runner **16** then fix them using screws **D**.



**Attention:** Correct position of the back column **18**. The side with the longer distance to the holes in back column (11cm) must be attached to the **side** panel.

### Attention

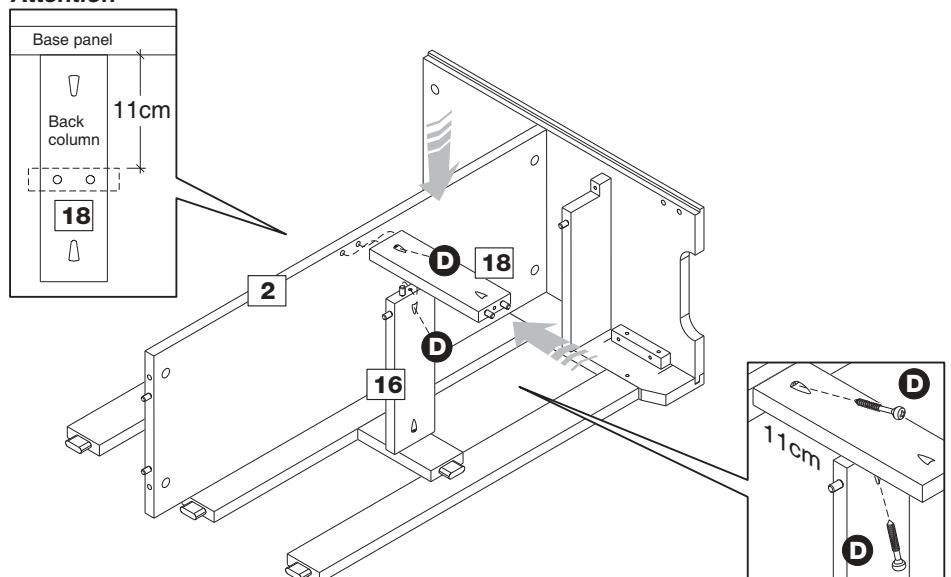

# Assembly Instructions

## Step 11

### Fixing cross rail.

Fit cross rail **10** to the left side panel **4** and back column **18** then fix it using screws **D**.

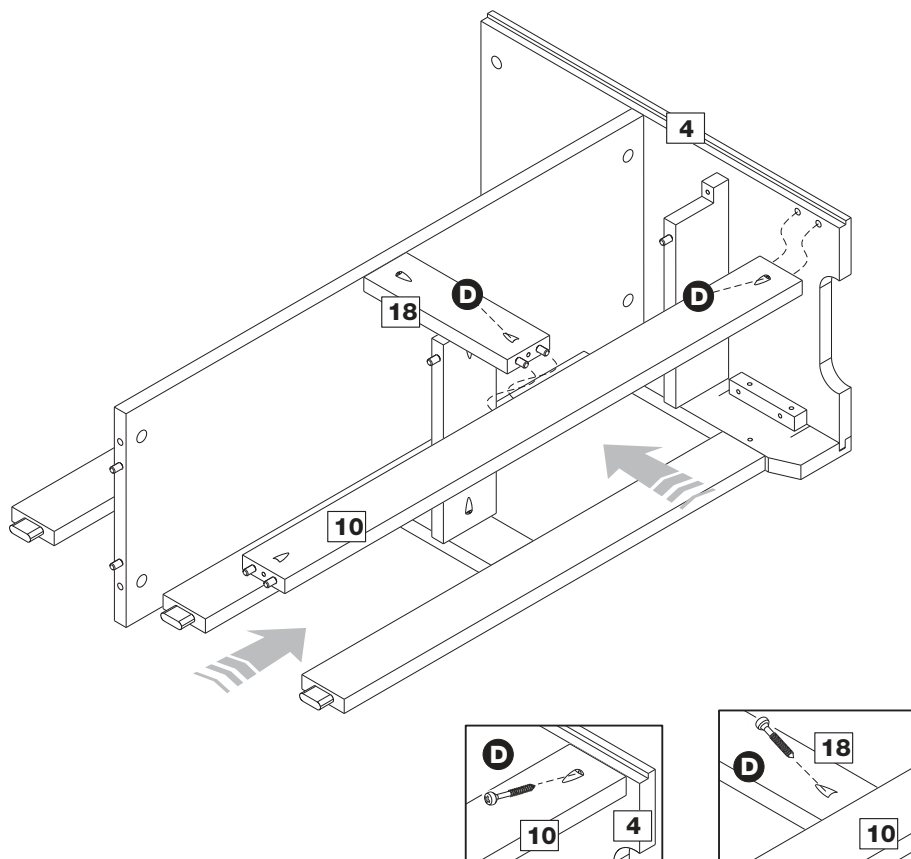

## Step 12

### Fixing right side panel.

With help, place right side panel **3** properly ensuring dowels and front frames are all fit into their holes at the same time.

Insert 2 locking nuts **G** into base panel where shown.

Use a screwdriver to turn locking nuts **G** clockwise to lock.

**Do not over tighten.**

Fix cross rail **10** to the side panel using screw **D**.

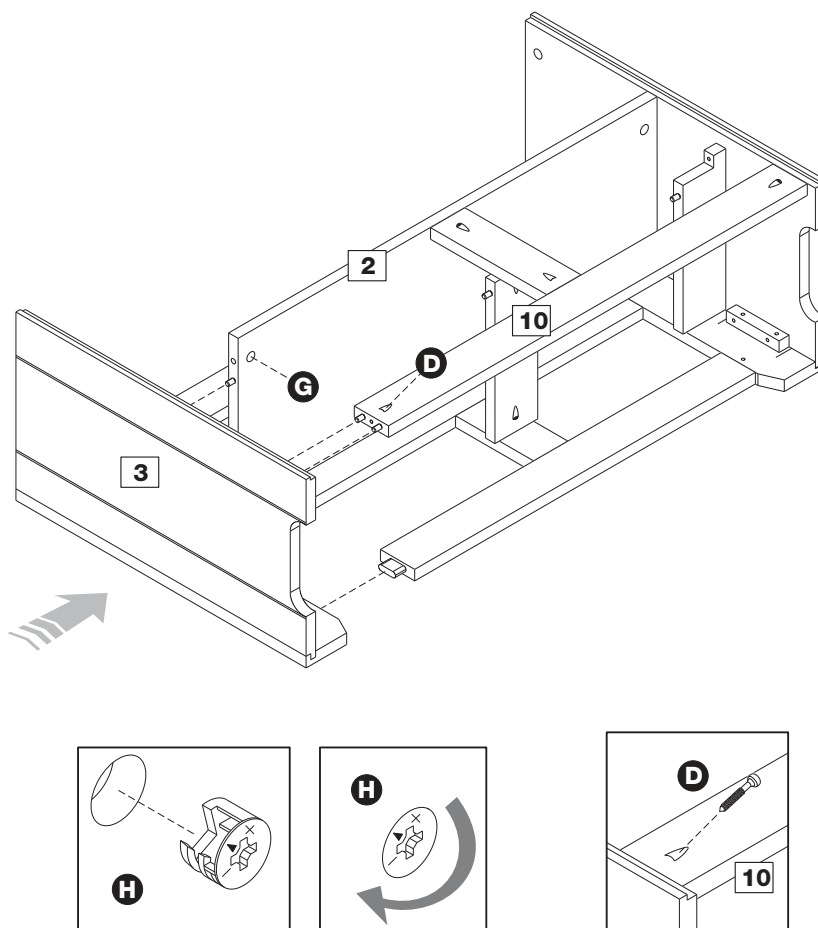

# Assembly Instructions

## Step 13

### Fixing top panel.

 **Caution:** Carefully lay the top panel **1** on a soft and clean surface to avoid damaging the product.

With help, fit cabinet to the top panel **1**.

Insert 4 locking nuts **G** into side panels where shown.

Use a screwdriver to turn locking nuts **G** clockwise to lock.

**Do not over tighten.**

Fix bottom front frame **9** to the right and left side panels using screws **B** as shown in the diagram.

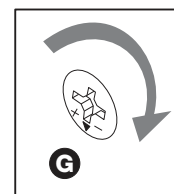
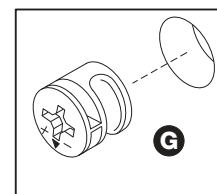
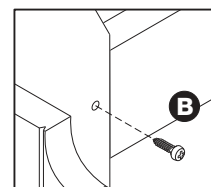
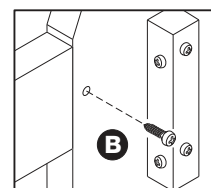
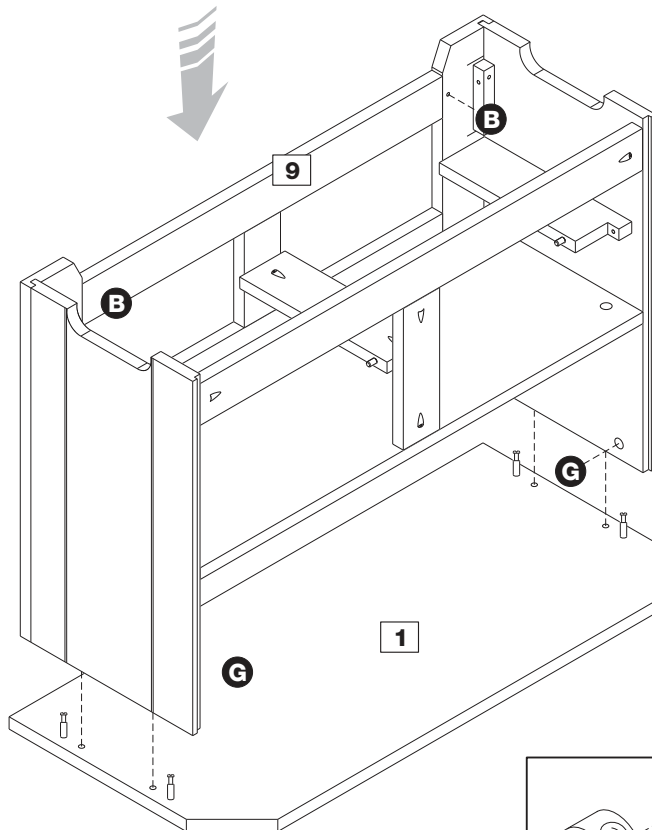

## Step 14

### Fixing back panels.

 **Important:** Cabinet **MUST** be 'square' when back panels are attached.

Attach back panel **7** using nails **I**.

With help, carefully stand the product upright.

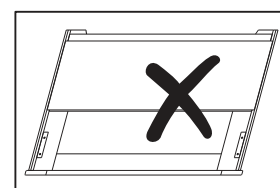
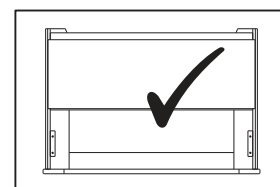
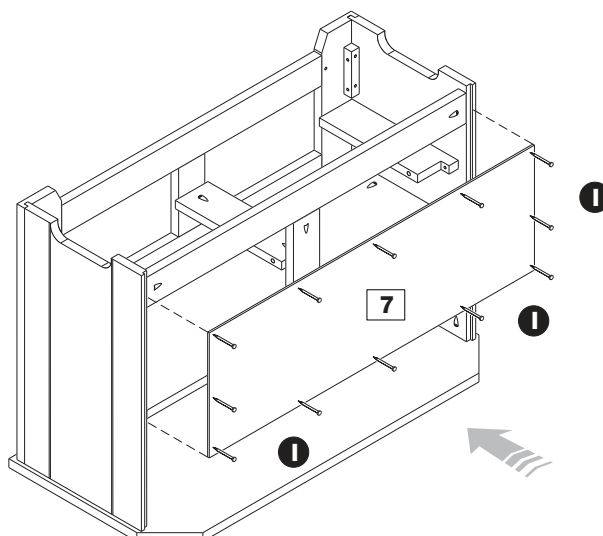

# Assembly Instructions

## Step 15

### Drawer assembly.

**a:** Attach drawer sides **12** to the drawer front **11** using screws **C**.

**b:** Slide drawer bottom **14** into slots on drawer sides and position drawer back **13** in place.

**c:** Holding the drawer back **13**, press the drawer sides and fix them using screws **C**.

**d:** Using bolts **E** attach drawer handle **H** to drawer front.

Repeat step 15 for the other drawer.

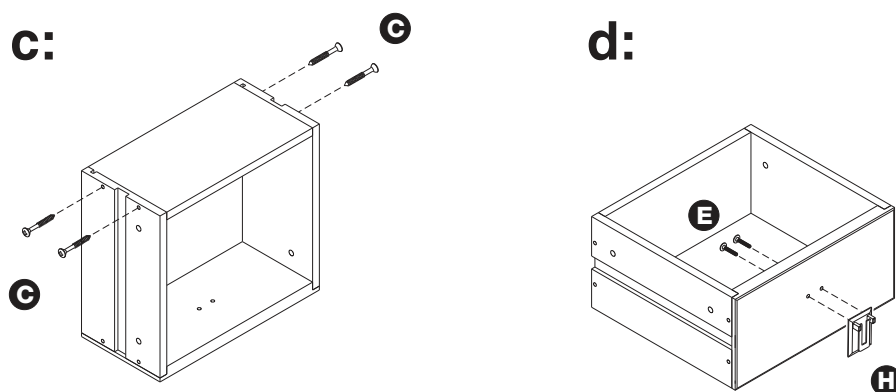
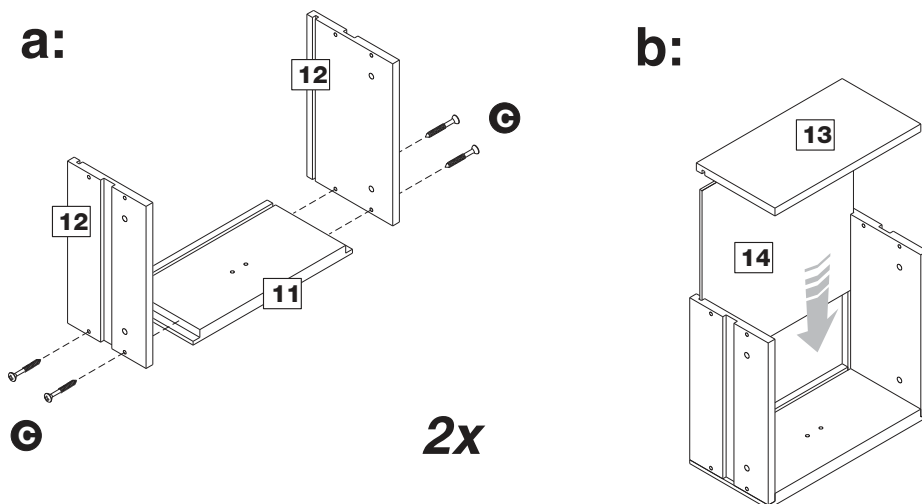

## Step 16

Insert drawers into unit. With the back of the drawers past the front frames, use a hammer to tap dowels **A** in flush to drawer sides. This is a safety catch to stop drawer falling out.

Assembly is complete.

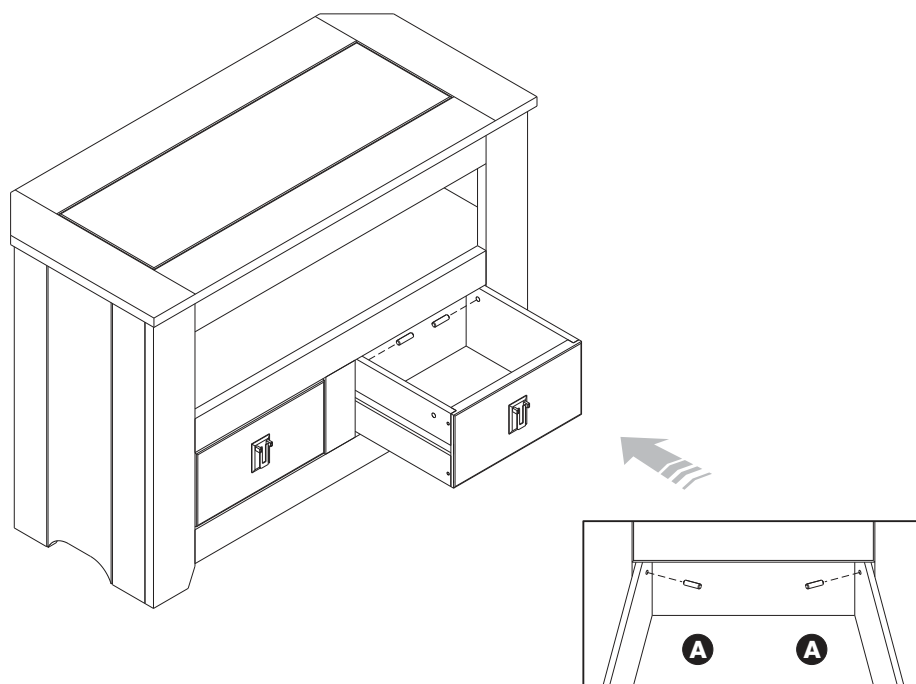

If you need help or have damaged or missing parts, call the **Customer Helpline: 03456 400 800**