

# Scandinavia - Desk

Assembly Instructions - Please keep for future reference

459/8305

473/9504

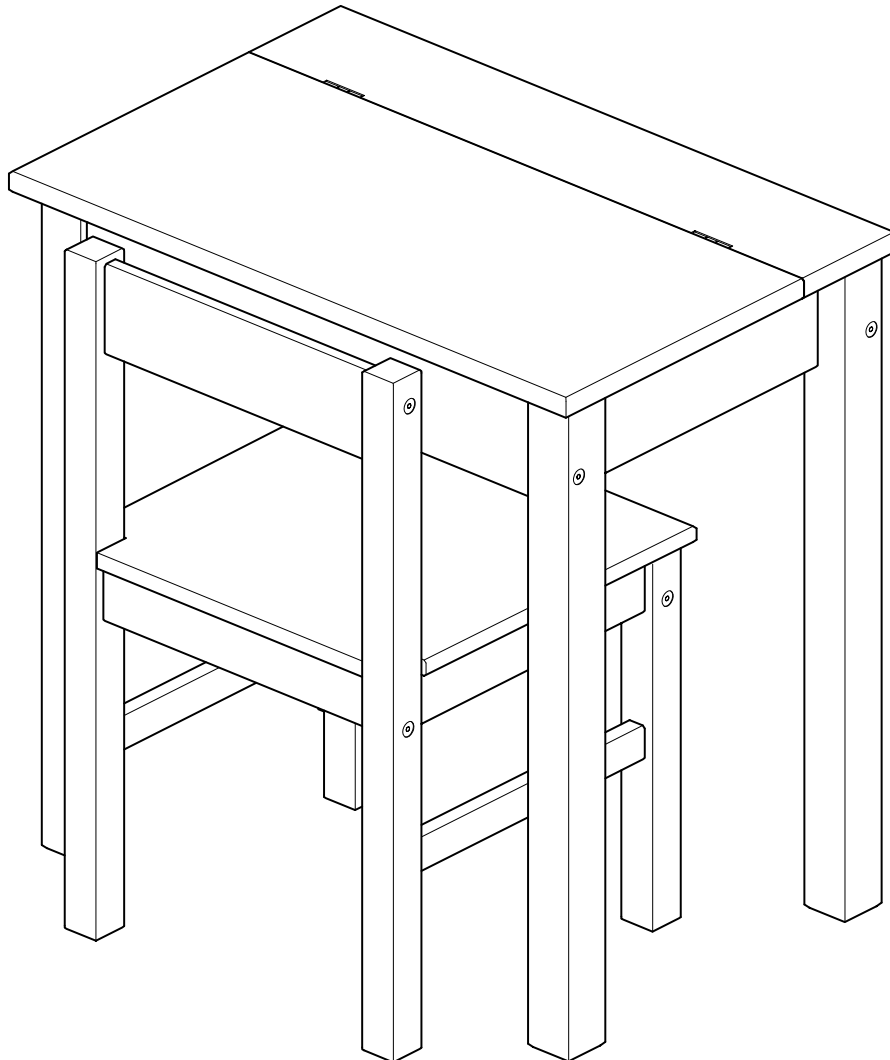

## Dimensions

### Table

Width - 59cm

Depth - 39cm

Height - 60cm

### Chair

Width - 36cm

Depth - 35cm

Height - 60cm

**Important - Please read these instructions fully before starting assembly**

If you need help or have damaged or missing parts, call the **Customer Helpline:**  
**Argos = 0345 640 0800**



# Safety and Care Advice

## Important: Retain these instructions for future reference

- This product is suitable for children in the age of 6 or above.
- Ensure that fingers and legs are clear of all adjustments when adjusting this product.
- Manufacturer (or supplier): Argos LTD. MK 9 2 NW.

### Important - Please read these instructions fully before starting assembly

- Check you have all the components and tools listed on pages 2 and 3.
- Do not stand on the chair.
- Remove all fittings from the plastic bags and separate them into their groups.
- Assemble the item as close to its final position (in the same room) as possible.
- Keep children and animals away from the work area, small parts could choke if swallowed.
- Assemble on a soft level surface to avoid damaging the unit or your floor.
- Make sure you have enough space to layout the parts before starting.
- Parts of the assembly will be easier with 2 people.
- Assembly of this product must be carried out by a competent adult.
- During assembly children should be kept away from the product due to possible risk of injury.
- To reduce the likelihood of damaging your product please ensure that your power drill is set on a low torque setting.
- Dispose of all packaging carefully and responsibly.
- Do not use this item if any components are missing or damaged.
- The max. safe weight should be 90kgs.
- Do not use the chair as step ladder.

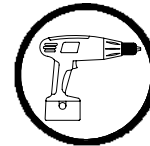

### Care and maintenance

- Only clean using a damp cloth and mild detergent, do not use bleach or abrasive cleaners.
- From time to time check that there are no loose screws on this unit.
- This product should not be discarded with household waste. Take to your local authority waste disposal centre.

### Handy Hints

- Assemble all parts and bolts loosely during assembly, only once the product is complete should you fully tighten the bolts.
- Regularly check and ensure that all bolts and fittings are tightened properly.

**Note:** if required the next page can be cut out and used as reference throughout the assembly. Keep this page with these instructions for future reference.

# Components - Panels

If you have damaged or missing components, call the Customer Helpline: Argos = 0345 640 0800

Please check you have all the panels listed below

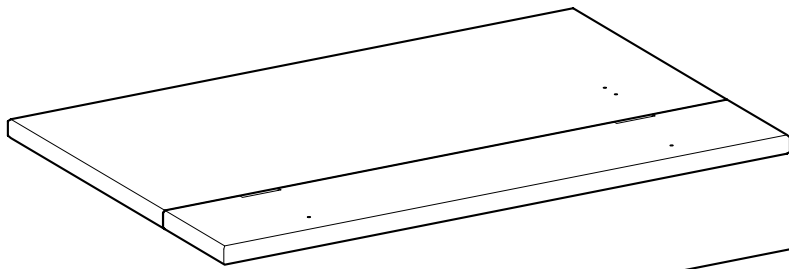

**1** Table top (59 x 39cm)

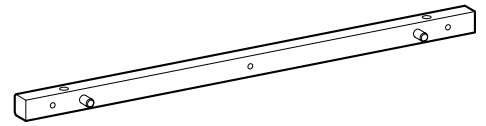

**6** Support rail (46.8 x 2cm)

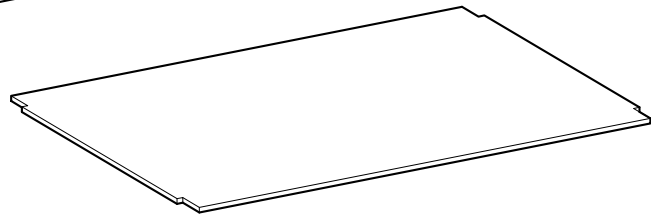

**7** Bottom (48 x 33.8cm)

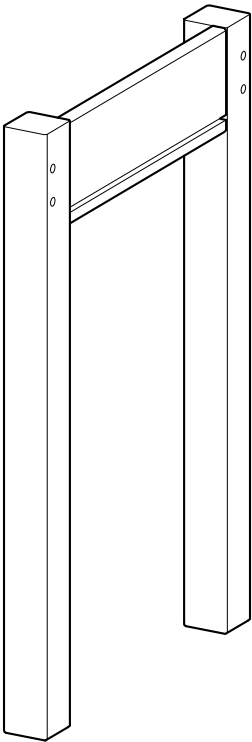

**2** Left side (58.2 x 37cm)

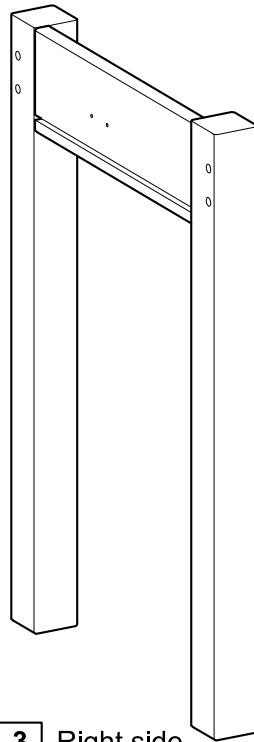

**3** Right side (58.2 x 37cm)

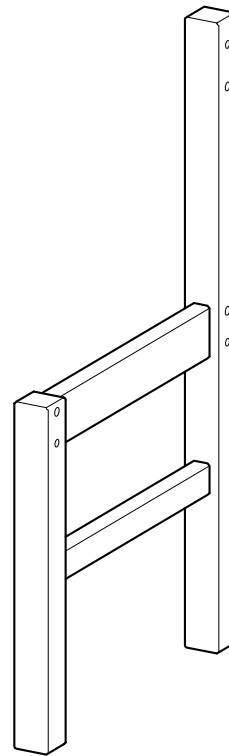

**8** Left leg (60 x 34cm)

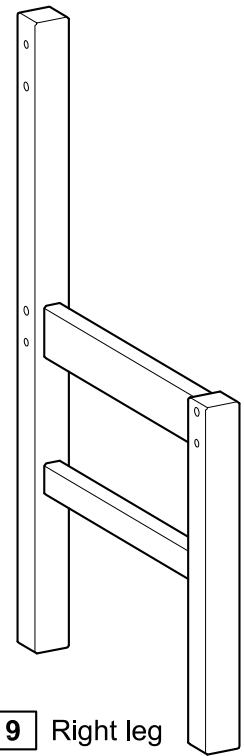

**9** Right leg (60 x 34cm)

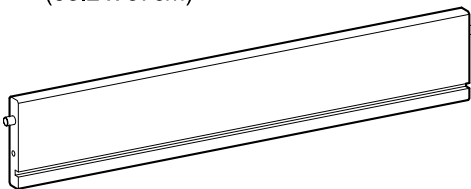

**4** Front rail (47 x 8.5cm)

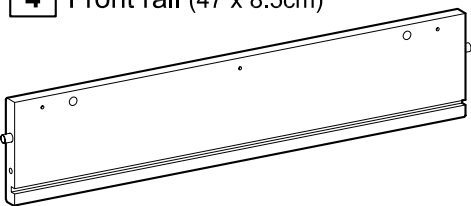

**5** Back rail (47 x 10cm)

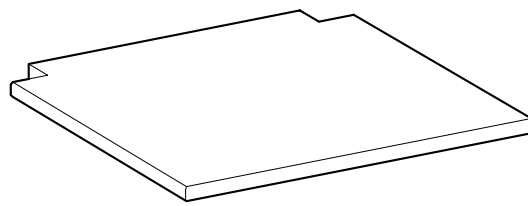

**12** Seat (36 x 34.8cm)

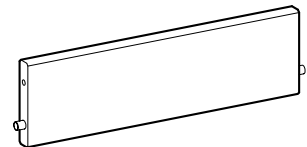

**10** Top plinth (28 x 8cm)

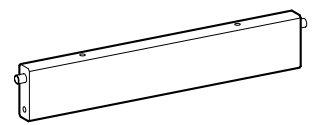

**11** Side rail x 2 (28 x 5cm)



# Components - Fittings

Please check you have all the fittings listed below

**Note:** The quantities below are correct amount to complete the assembly. In some cases more fittings may be supplied than are required.

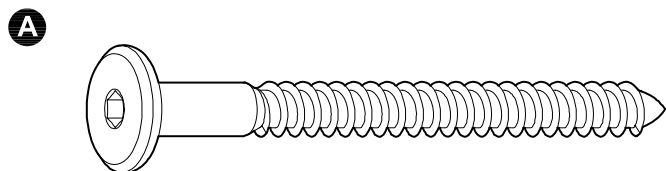

**A**

70mm Screw x 10

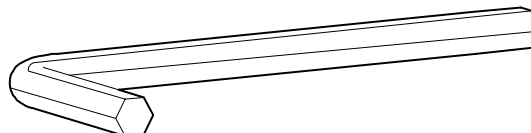

**B**

Allen key x 1

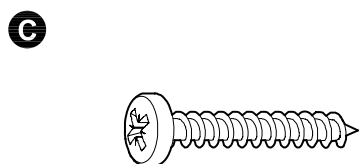

**C**

30mm Screw x 5

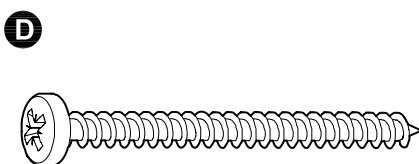

**D**

55mm Screw x 4

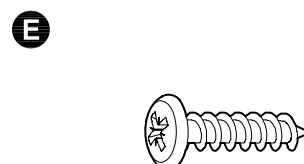

**E**

15mm Screw x 4

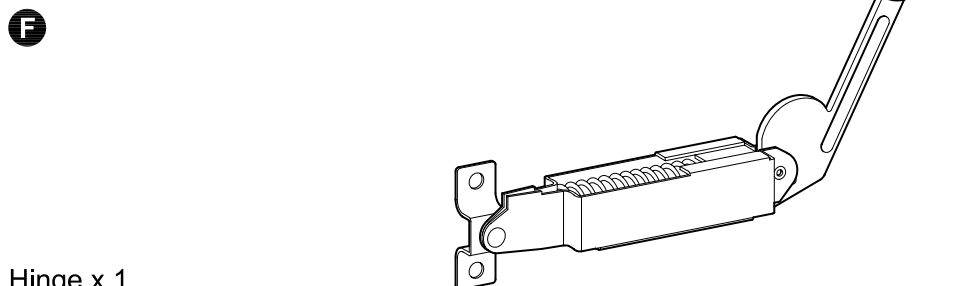

**F**

Hinge x 1

## Tools required

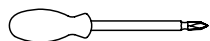

Phillips screwdriver  
(medium & large)

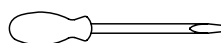

Flatblade screwdriver  
(medium)

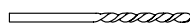

Suitable drill bit  
(for use with wall plug)

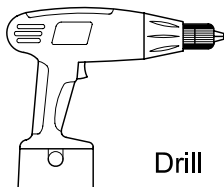

Drill



Small  
hammer



Ruler/tape  
measure

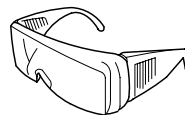

Eye protection  
(when using a  
hammer or glue)

## Ruler - Use this ruler to help correctly identify the screws



The screws length is measured from the head to the point (30mm screw shown).

# Components - Key Diagram Table

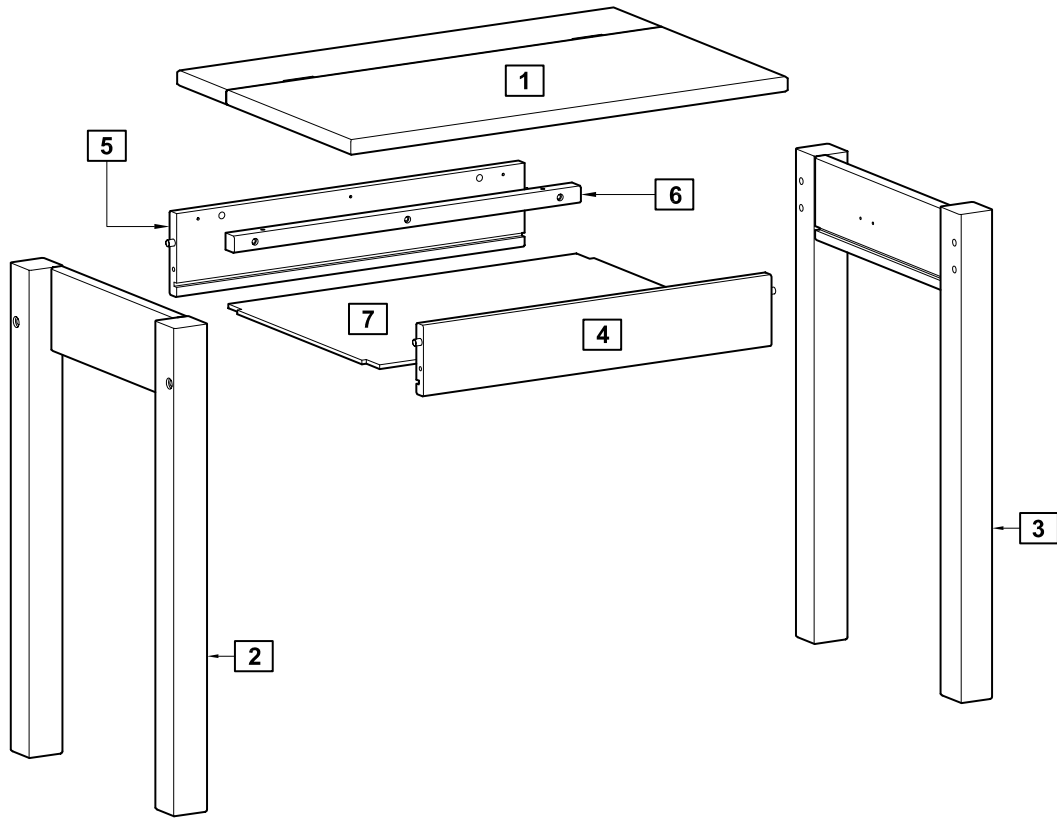

# Components - Key Diagram Chair

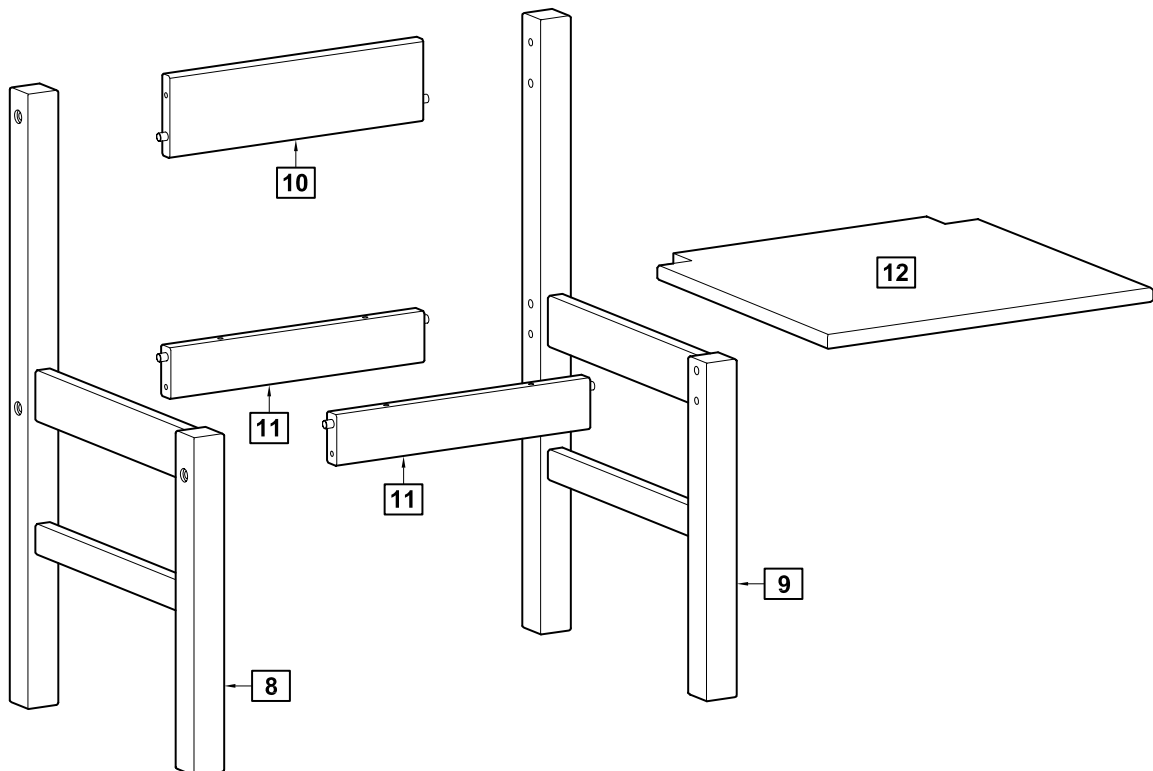

# Assembly Instructions

## Assembly of the table.

### Step 1

Mounting the front rail and the back rail onto the left side.

Press the front rail **4** and the back rail **5** onto the left side **2**.

Fix the front rail and the back rail using screws **A** and allen key **B** through the holes indicated.

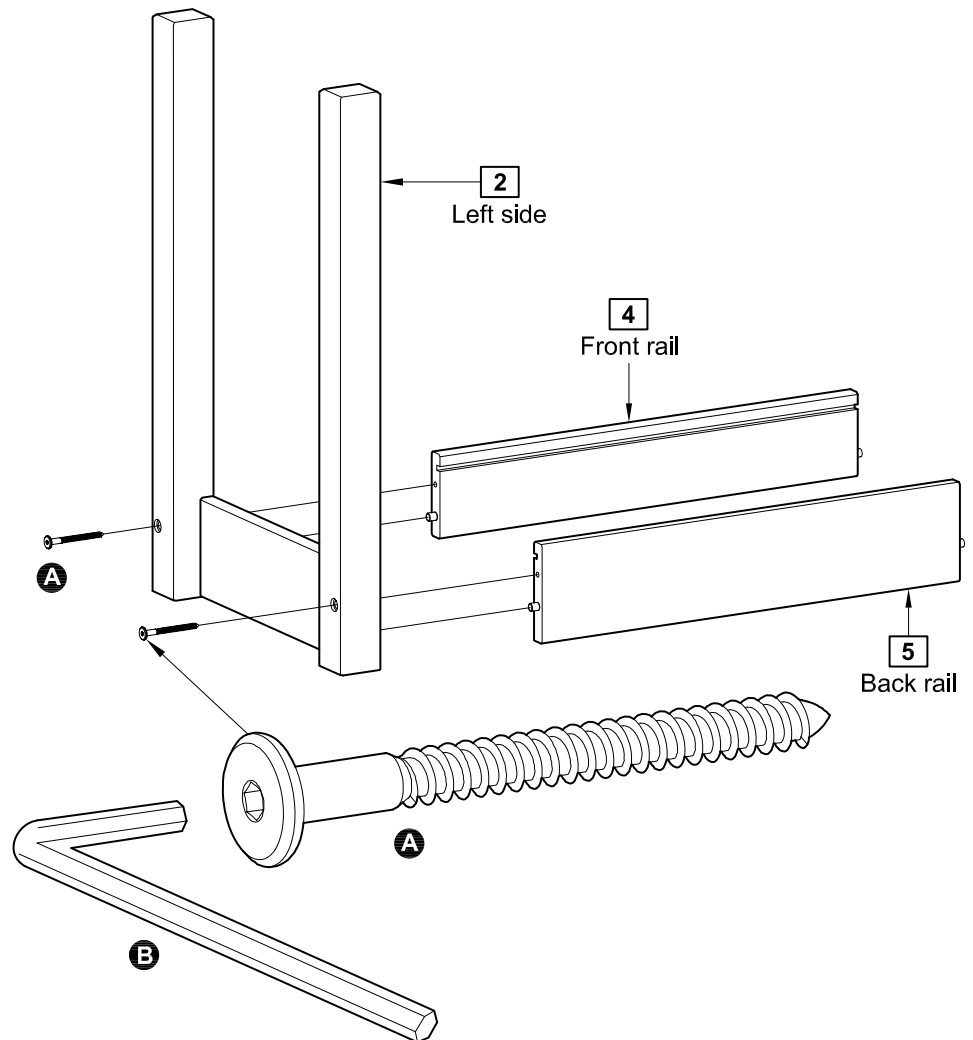

### Step 2

Slide the bottom into the front rail, back rail and the left side.

Slide the bottom **7** into the grooves of the front rail **4**, back rail **5** and the left side **2**.

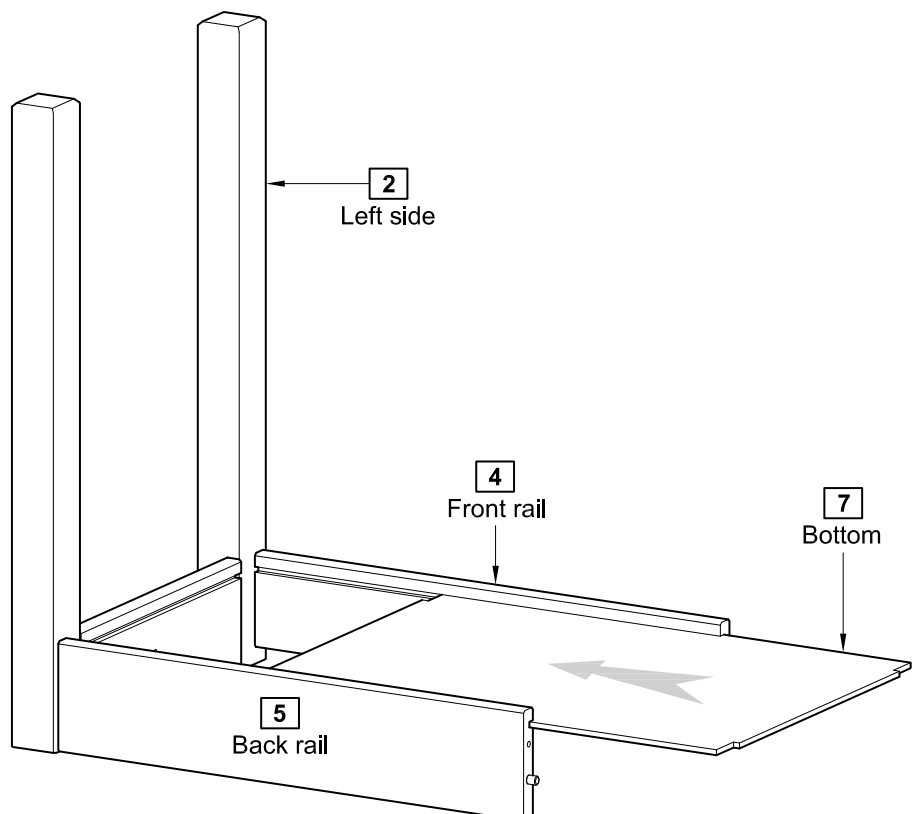

# Assembly Instructions

## Step 3

**Mounting the right side onto the front rail and the back rail.**

Press the right side **3** onto the front rail **4** and the back rail **5**.

Fix the right side using screws **A** and allen key **B** through the holes indicated.

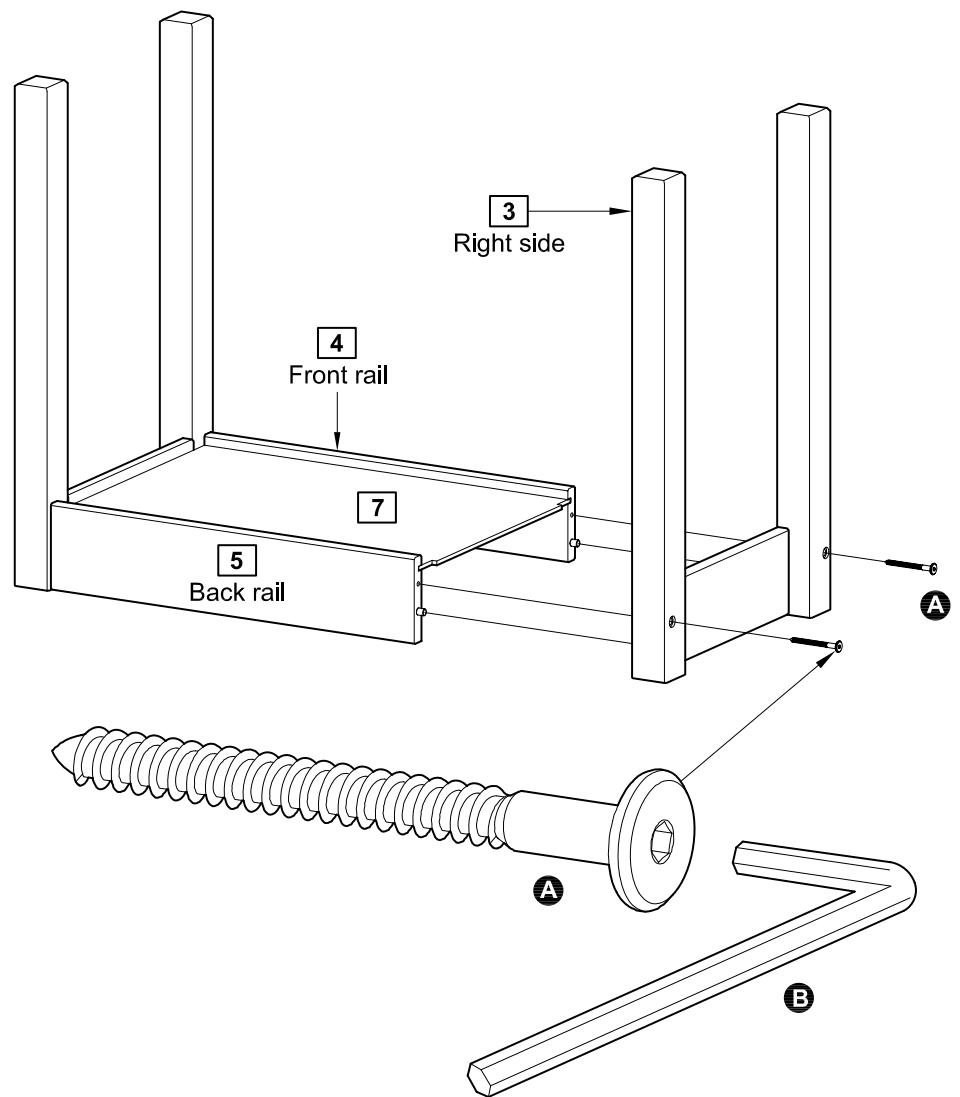

## Step 4

**Mounting the support rail onto the table top.**

Press the support rail **6** onto the table top **1**.

Fix the support rail using screws **C** through the holes indicated.

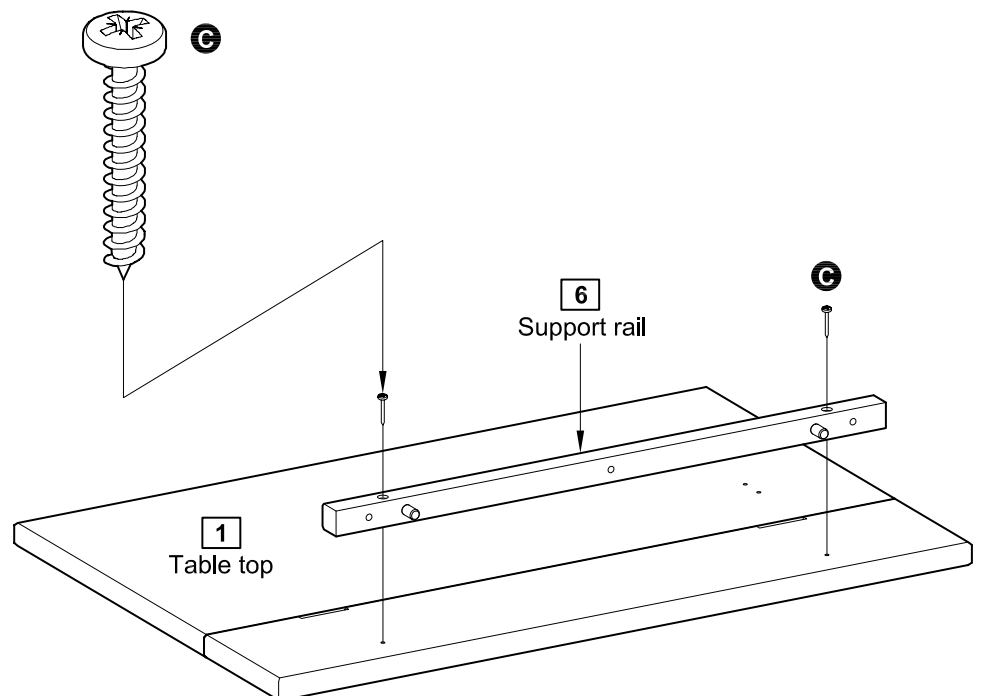

# Assembly Instructions

## Step 5

### Mounting the support rail onto the back rail

Press the support rail **6** onto the back rail **5**.

Fix the support rail using screws **G** through the holes indicated.

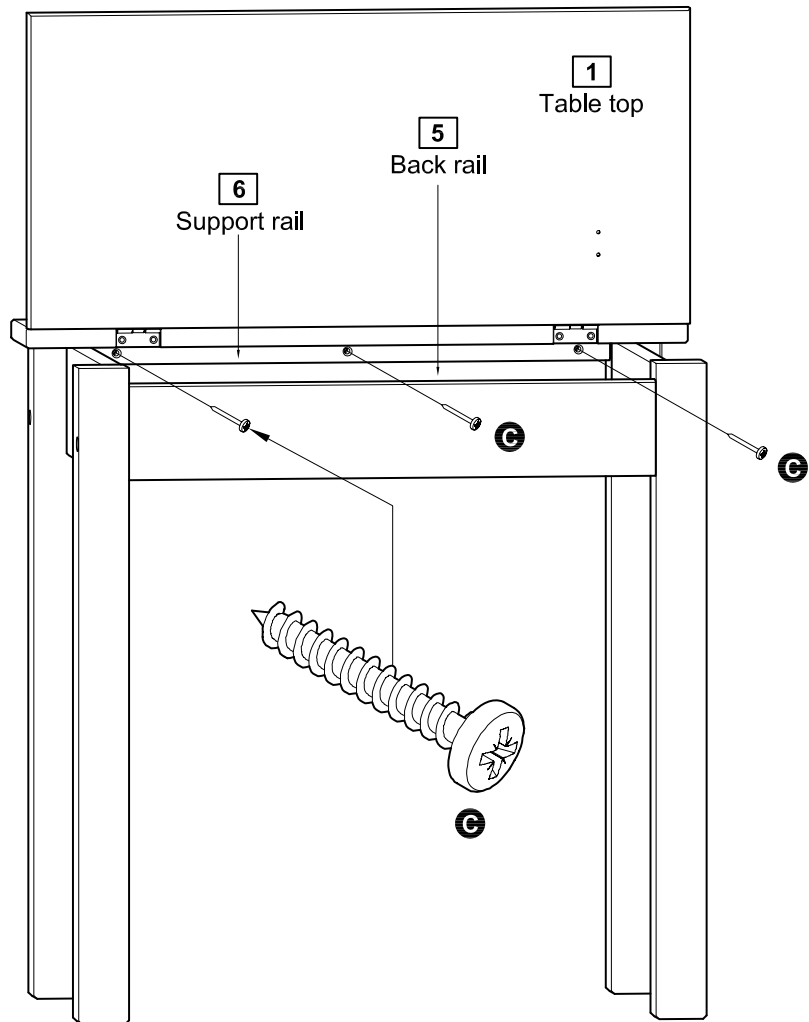

## Step 6

### Mounting the hinge onto the right side.

Fix the hinge **F** onto the right side **3** using screws **E** into the pre-drilled holes.

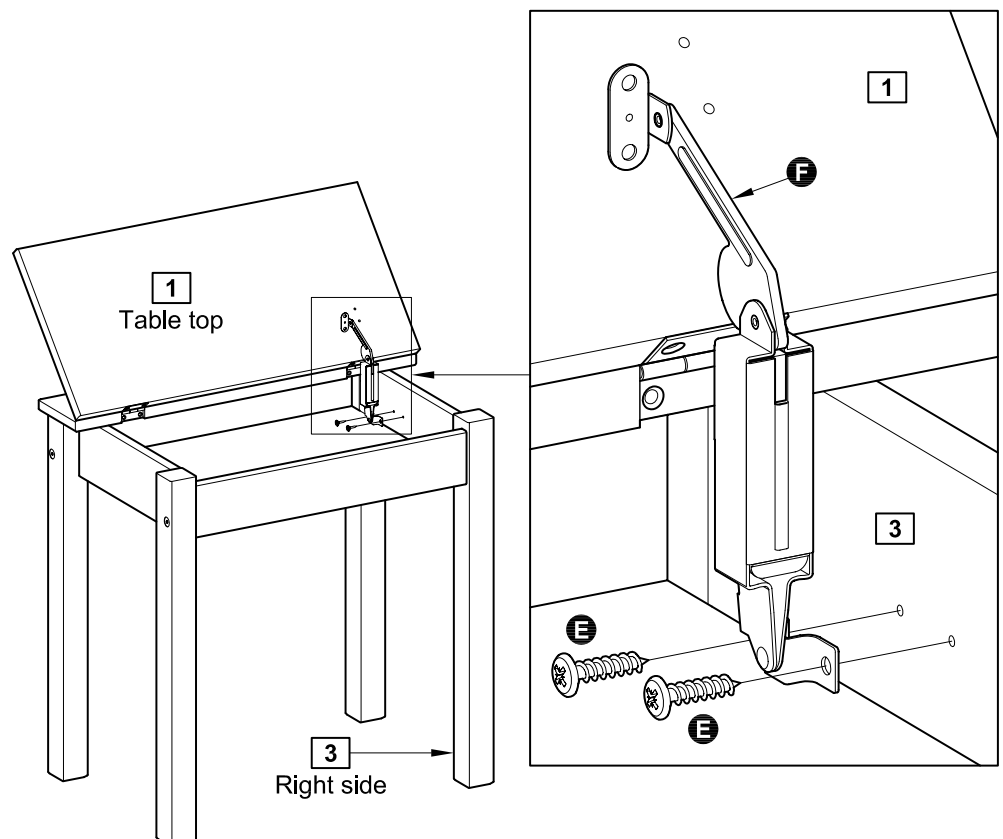



# Assembly Instructions

## Step 7

### Mounting the hinge onto the table top.

Fix the hinge **F** onto the table top **1** using screws **E** into the pre-drilled holes.

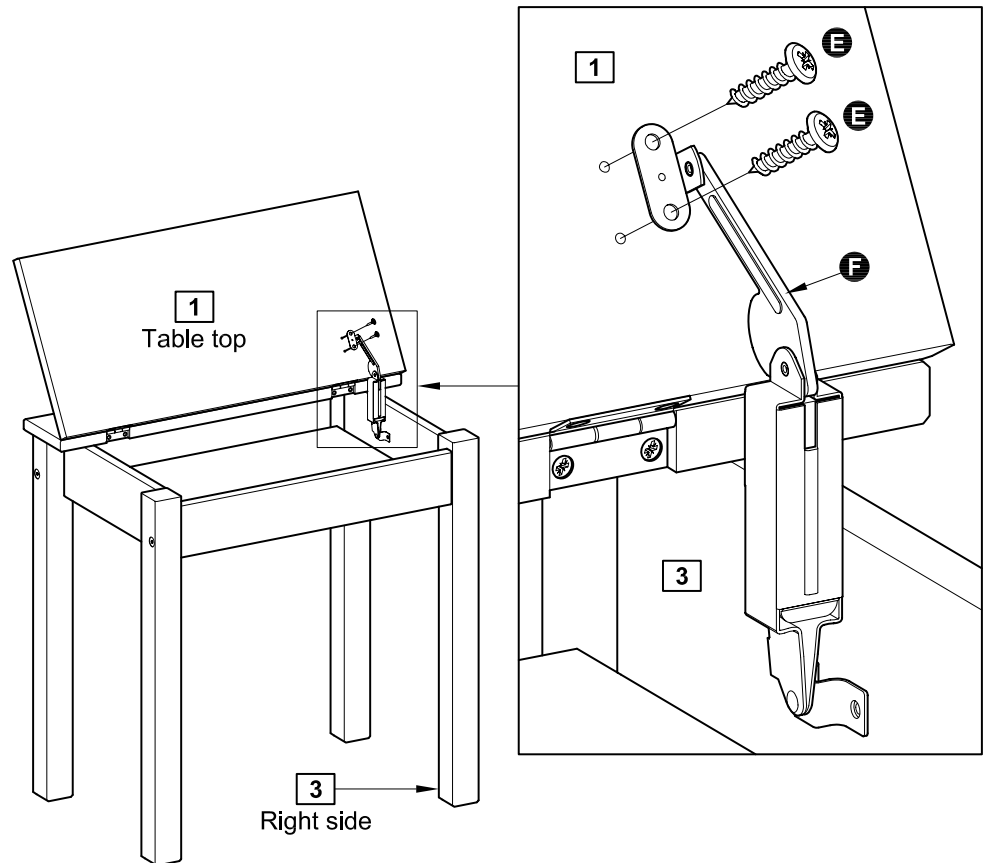

## Assembly of the chair.

## Step 8

### Mounting the top plinth and the side rails onto the left leg.

Press the top plinth **10** and the side rails **11** onto the left leg **8**.

Fix the top plinth and the side rails using screws **A** and allen key **B** through the holes indicated.

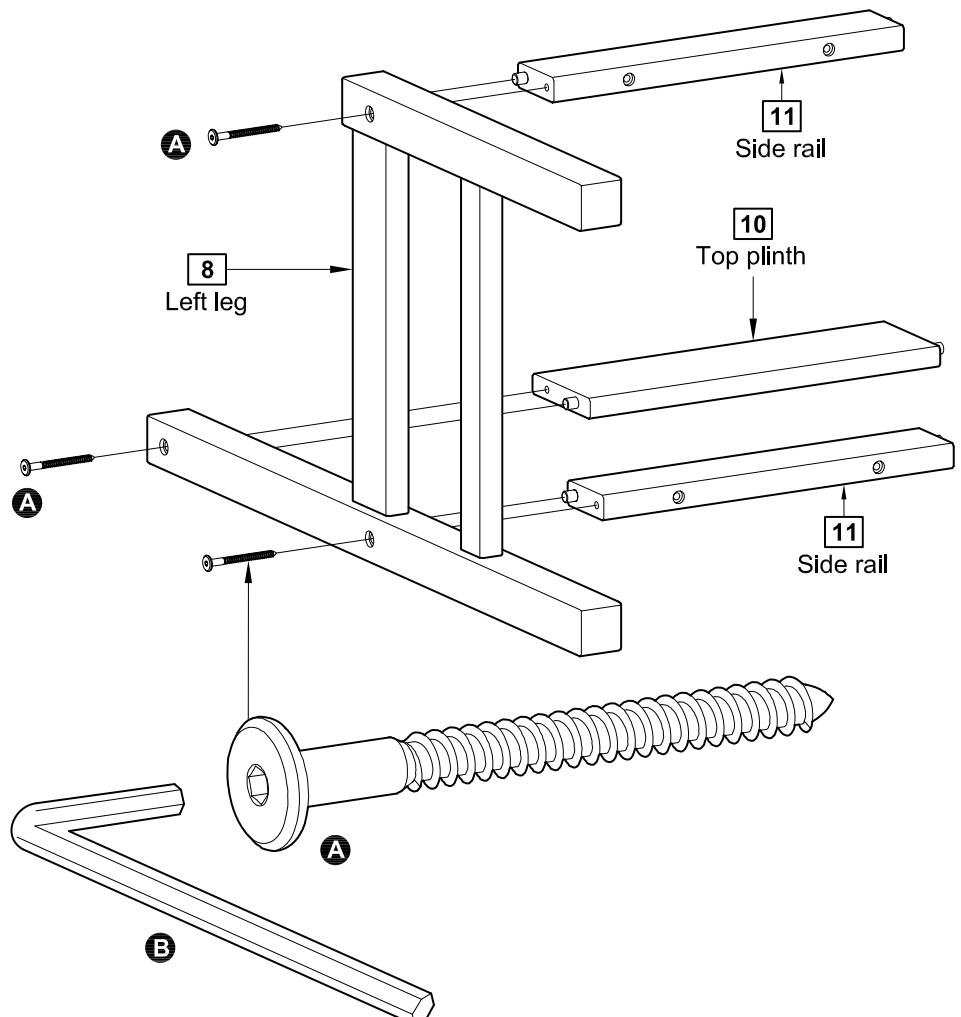

# Assembly Instructions

## Step 9

**Mounting the right leg onto the top plinth and the side rails.**

Press the right leg **9** onto the top plinth **10** and the side rails **11**.

Fix the right leg using screws **A** and allen key **B** through the holes indicated.

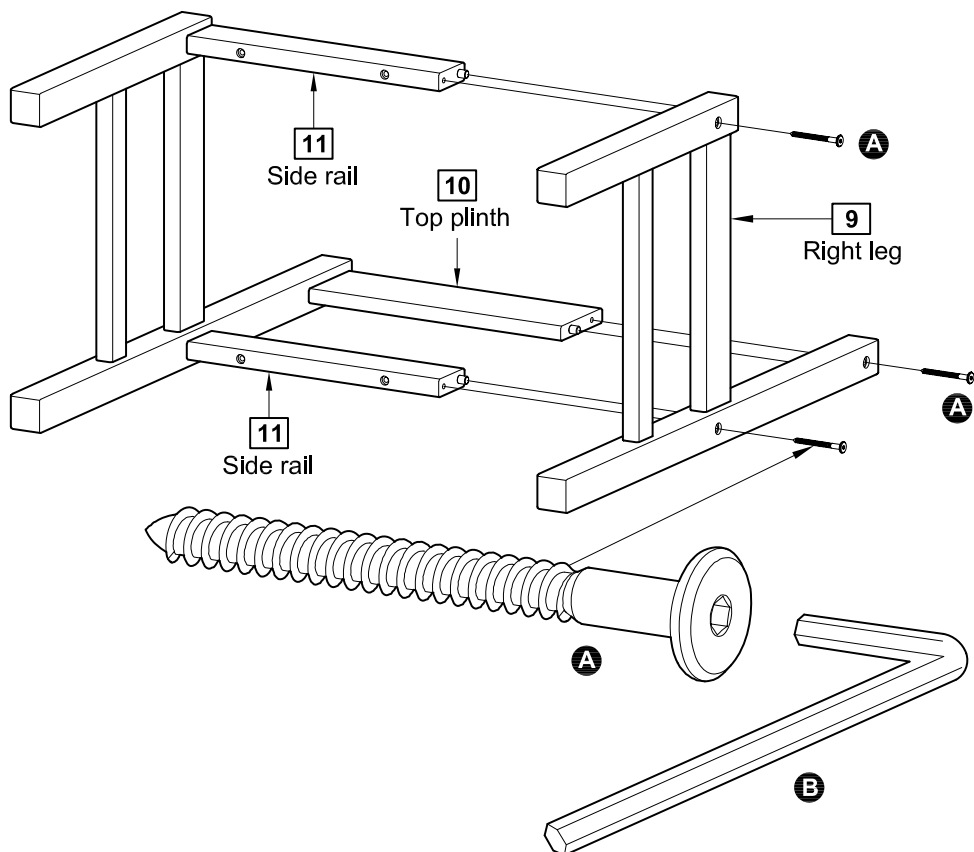

## Step 10

**Adding the seat to the chair.**

Fix the side rails **11** onto the seat **12** using screws **D** through the holes indicated.

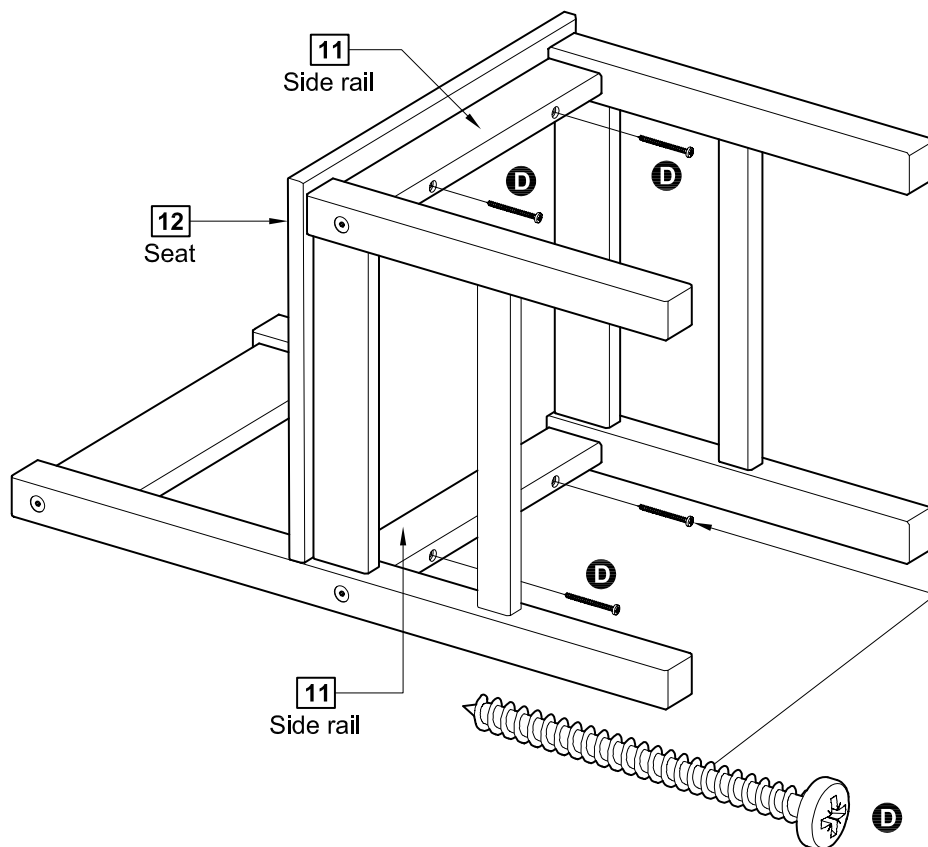

**Assembly is complete.**

If you need help or have damaged or missing parts, call the **Customer Helpline:**  
**Argos = 0345 640 0800**

## Dear Customer.

**Please note that the product you have purchased is a natural living timber.**

**Just like nature itself, wood varies in shape and colour. Knots, vein patterns, resin pockets and colour differences contribute to giving the piece of furniture its beauty and form - a natural part of solid wood.**

**Although the tree has been cut down and dried, it is still alive and therefore will react to high and low temperatures, light, humidity, drought and time.**

**In cold and dry periods, the wood contracts which may lead to small cracks in the piece of furniture. The reverse happens in warm and humid periods where the wood expands and this may result in slight unevenness.**

**The colour of the wood also changes with time, particularly if the furniture is placed in a light place. This is a natural process and part of owning a piece of furniture made of solid wood.**

**Any flexing that has occurred during transport will re-correct itself once this product is correctly assembled.**

**Tighten all joints of the furniture after six months.**

**Please keep these instructions in a safe place for future use.**