

**Important!**  
Weekly and  
monthly cleaning  
required.

**Register**  
Your free 2 year  
guarantee today.





## IMPORTANT SAFETY INSTRUCTIONS

BEFORE USING THIS APPLIANCE READ ALL INSTRUCTIONS AND CAUTIONARY MARKINGS IN THIS MANUAL AND ON THE APPLIANCE

When using an electrical appliance, basic precautions should always be followed, including the following:



### WARNING

**THE APPLIANCE AND THE REMOTE CONTROL BOTH CONTAIN MAGNETS.**

1. Pacemakers and defibrillators may be affected by strong magnetic fields. If you or someone in your household has a pacemaker or defibrillator, avoid placing the remote control in a pocket or near to the appliance.
2. Credit cards and electronic storage media may also be affected by magnets and should be kept away from the remote control and the top of the appliance.



### WARNING

These warnings apply to the appliance, and also where applicable, to all tools, accessories, chargers or mains adaptors.

**TO REDUCE THE RISK OF FIRE, ELECTRIC SHOCK, OR INJURY:**

3. Extreme caution is necessary when any appliance is used by or near children or infirm persons and whenever it is left operating and unattended.
4. This Dyson appliance can be used by children aged from 8 years and above and persons with reduced physical, sensory or reasoning capabilities, or lack of experience and knowledge, only if they have been given supervision or instruction by a responsible person concerning use of the appliance in a safe way and understand the hazards involved. Cleaning and user maintenance shall not be made by children without supervision.
5. Use only as described in this Dyson Operating Manual. Do not carry out any maintenance other than that shown in this manual, or advised by the Dyson Helpline.
6. Ensure appliance is fully assembled in line with the instructions before use. Do not dismantle the appliance or use without the loop amplifier fitted.
7. Do not allow to be used as a toy. Close attention is necessary when used by or near children. Children should be supervised to ensure that they do not play with the appliance or remote control.
8. Suitable for dry locations ONLY. Do not use outdoors or on wet surfaces. Do not use in bathrooms, laundry areas or similar indoor locations. Never locate the appliance where it may fall into a bath or other water container. Do not use or store where it may get wet or in the immediate surroundings of a bath, a shower, or a swimming pool.
9. Do not use in areas where petrol, paint, or flammable liquids are used or stored or where their vapours are present. Do not use in conjunction with or directly next to an air freshener or similar products.
10. Do not locate directly below or above a mains electricity supply socket.
11. Always plug directly into a wall socket.
12. Do not handle any part of the plug or appliance with wet hands.
13. Do not use with a damaged cable or plug. If the supply cable is damaged it must be replaced by Dyson, its service agent or similarly qualified person in order to avoid a hazard.
14. If the appliance is not working as it should, has received a sharp blow, has been dropped, damaged, left outdoors, or dropped into water, do not use and contact the Dyson Helpline.
15. Contact the Dyson Helpline when service or repair is required. Do not disassemble the appliance as incorrect reassembly may result in an electric shock or fire.
16. Do not unplug by pulling on the cable. To unplug, grasp the plug, not the cable.
17. Do not stretch the cable or place the cable under strain. Keep cable away from heated surfaces.
18. Do not route the cable under furniture or appliances. Do not cover cable with throw rugs, runners or similar coverings. Arrange cable

away from traffic area and where it will not be tripped over.

19. To prevent a possible fire, do not use with any opening or exhaust blocked, and keep free of dust, lint, hair, and anything that may reduce airflow. Do not put any object into the inlet grill or the exhaust opening as this may cause an electric shock or fire, or damage the appliance.
20. Do not use near furnaces, fireplaces, stoves or other high temperature heat sources.
21. Turn off all controls before unplugging.
22. Unplug when not in use for extended periods and before filling, cleaning, maintenance or servicing.
23. When refilling, only do so as described in this Dyson operating manual. Do not use hot water.
24. Always place the appliance on a firm, flat, level surface.
25. Do not use on soft surfaces, such as a bed, where openings may become blocked.
26. Do not place the appliance in an area where it is accessible to children.
27. Always carry the appliance by the base, do not carry it by the loop amplifier.
28. Do not tilt, move, or attempt to empty the appliance while it is operating.
29. Do not use unless the appliance has been cleaned according to instructions.
30. Use only cleaning agents recommended by Dyson.
31. Do not pour water into any openings except for the water tank.
32. This appliance must only be supplied at safety extra low voltage corresponding to the marking on the base. Dyson recommends that this appliance is only to be used with the power supply unit provided with it.
33. This appliance contains a UV-C emitter. Unintended use of the appliance or damage to the housing may result in the escape of dangerous UV-C radiation. UV-C radiation may, even in little doses, cause harm to the eyes and skin.

34. **WARNING** – This appliance contains a UV-C emitter. Do not stare at the light source.
35. If any part is replaced the replacement must be fitted in its correct position.
36. Choking hazard - This remote control unit contains a small battery. Keep the remote control away from children and do not swallow the battery. If the battery is swallowed seek medical advice at once.

## IMPORTANT SAFETY FEATURES

For your safety this appliance is fitted with automatic cut-out switches that operate if it tips over. If the switches operate, unplug the appliance. Before restarting, check and clear any blockages, allow to dry and ensure the appliance is on a solid level surface.

## READ AND SAVE THESE INSTRUCTIONS

THIS DYSON APPLIANCE IS INTENDED FOR HOUSEHOLD USE ONLY



Do not pull on the cable.

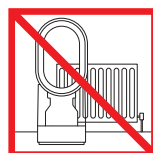

Do not store near heat sources.



Do not use near naked flames.



Do not carry by the loop amplifier.

# Thank you for choosing to buy a Dyson appliance.

After registering your free 2 year guarantee, your Dyson appliance will be covered for parts and labour for 2 years from the date of purchase, subject to the terms of the guarantee. If you have any questions about your Dyson appliance, call the Dyson Helpline with your serial number and details of where/when you bought the appliance.

Most questions can be solved over the phone by one of our trained Dyson Helpline staff.

This product is for household use and it is not intended for business purposes.

Your serial number can be found on your rating plate which is on the base of the appliance.

Alternatively, visit [www.dyson.co.uk/support](http://www.dyson.co.uk/support) (UK) or [www.dyson.ie/support](http://www.dyson.ie/support) (ROI) for online help, general tips and useful information about Dyson.

Note your serial number for future reference.



This illustration is for example purposes only.

For the latest information about this appliance and to make sure it has the latest software update, please visit the Dyson website.

## 3 Easy ways to register your free 2 year guarantee

### Register online

Visit our website to register your full parts and labour guarantee online. [www.dyson.co.uk/register](http://www.dyson.co.uk/register) or [www.dyson.ie/register](http://www.dyson.ie/register)

### Register by phone

Call our dedicated Helpline.

Open Monday to Friday 8am-8pm & Saturday and Sunday 8am-6pm.

UK: 0800 298 0298 or ROI: 01 475 7109

### Register by mail

Complete and return the form to Dyson in the envelope supplied.

Dyson contact details UK:

Website: [www.dyson.co.uk/support](http://www.dyson.co.uk/support)

Dyson Helpline: 0800 298 0298

Email: [askdyson@dyson.co.uk](mailto:askdyson@dyson.co.uk)

Address: Dyson Ltd, Tetbury Hill, Malmesbury, Wiltshire, SN16 0RP

ROI:

Website: [www.dyson.ie/support](http://www.dyson.ie/support)

Dyson Helpline: 01 475 7109

Email: [askdyson@dyson.co.uk](mailto:askdyson@dyson.co.uk)

Address: Dyson Ireland Limited, Unit G10, Grants Lane, Greenogue Business Park, Rathcoole, Dublin 24

# Know your humidifier

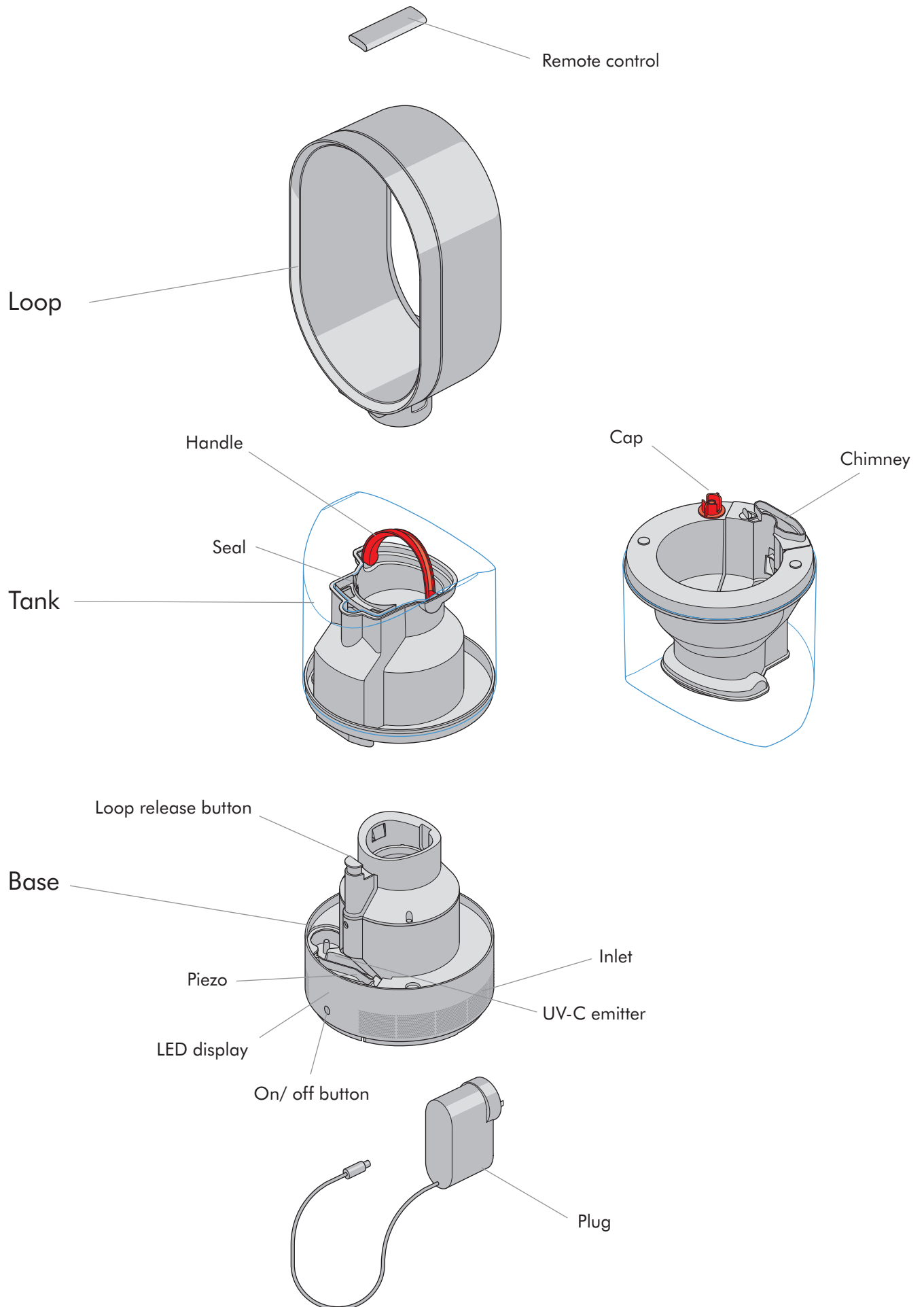

# Getting started

For the best performance place humidifier on the floor in the corner of the room, facing into the centre. It should be at least 1m from any wall. To avoid a cooling effect while humidifying, the unit should be at least 1m from any people. Consider placing near to air conditioning or heating devices to circulate air effectively.

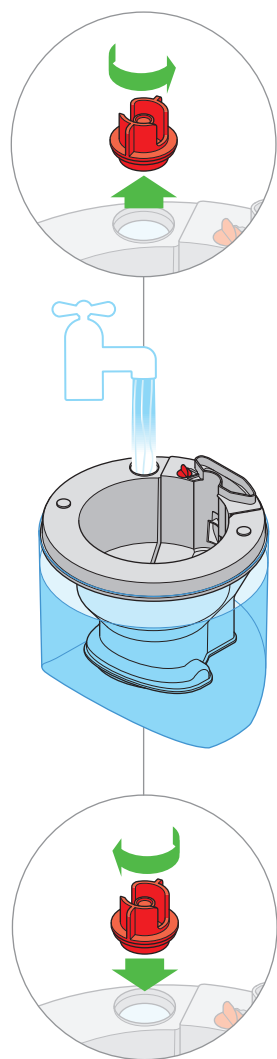

1

Unscrew the cap and fill the tank to the top. Replace the cap and screw until hand tight. Carry by the handle.

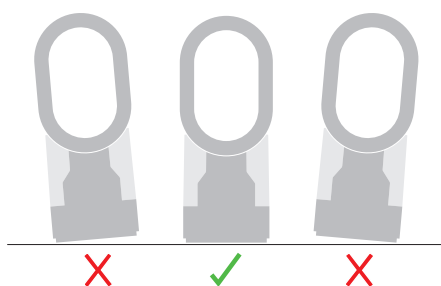
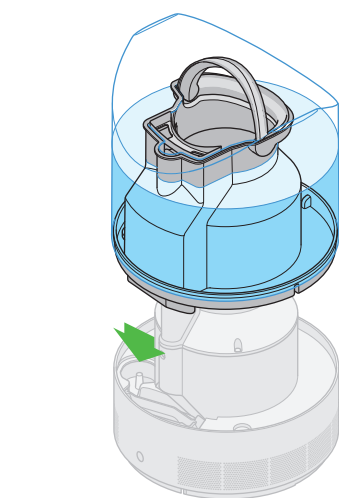

2

Place the tank on top of the base. Ensure the base is on a level surface, otherwise the appliance will not operate.

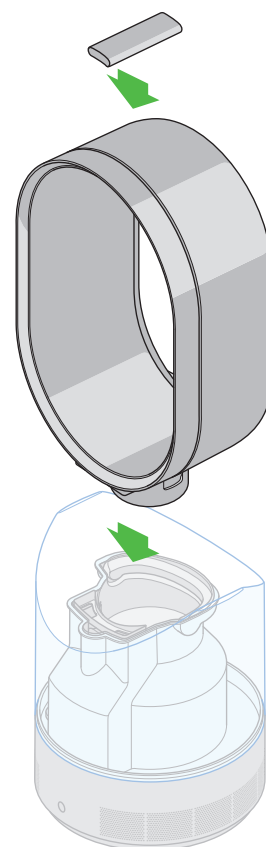

3

Place the loop amplifier on top of the tank. Push down until you hear a click. Remote control docks magnetically. Attach the remote control to the top of the appliance with the buttons facing down.

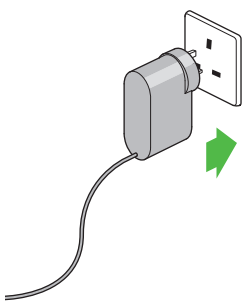
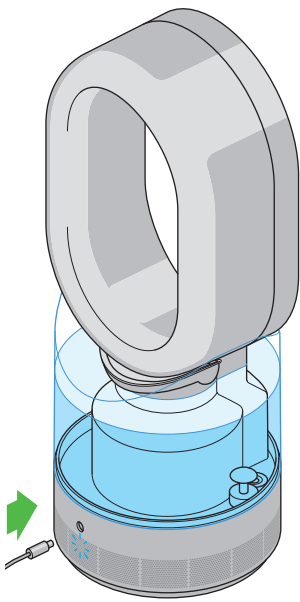

4

Plug into the socket and base. A small blue LED on the back of the appliance lights up to confirm that the appliance has power.

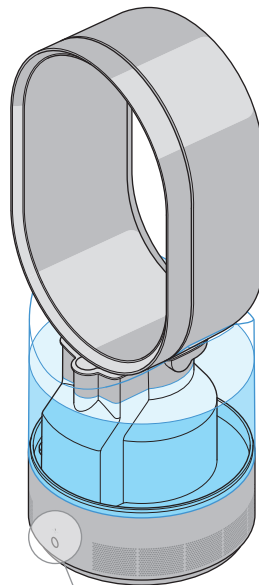

5

Switch 'ON'. The water treatment procedure automatically starts. Water passes over a UV-C emitter to ensure that it is 99.9% bacteria-free before misting commences. This takes approximately 3 minutes. (During this time humidity targets can be set and fan mode can be switched ON'.)

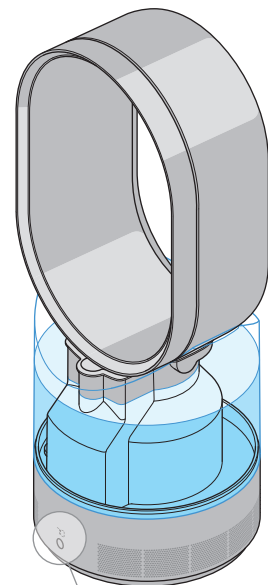

6

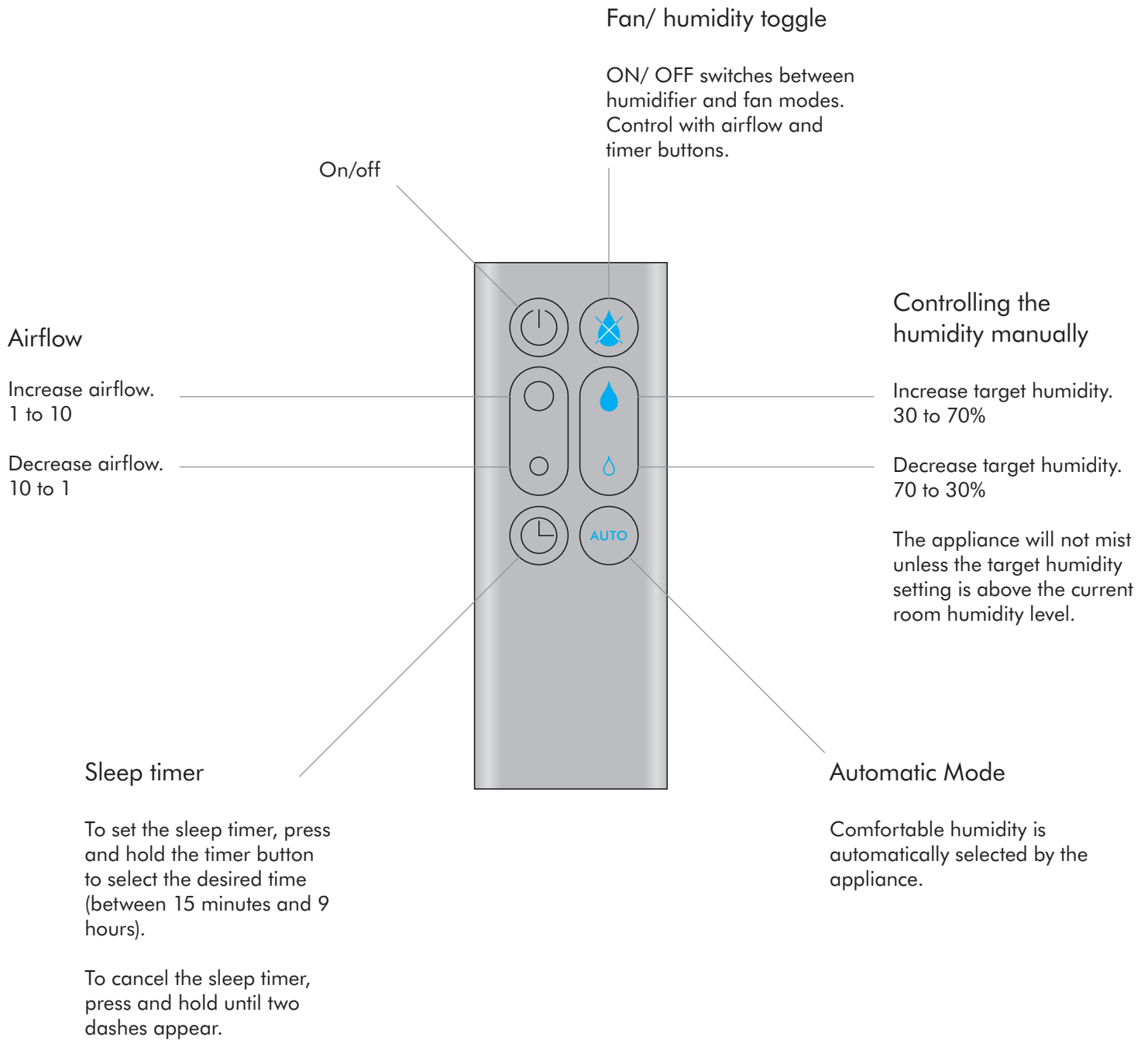

After 3 minutes the appliance will start to humidify. The display will show the target humidity setting.

# How to use



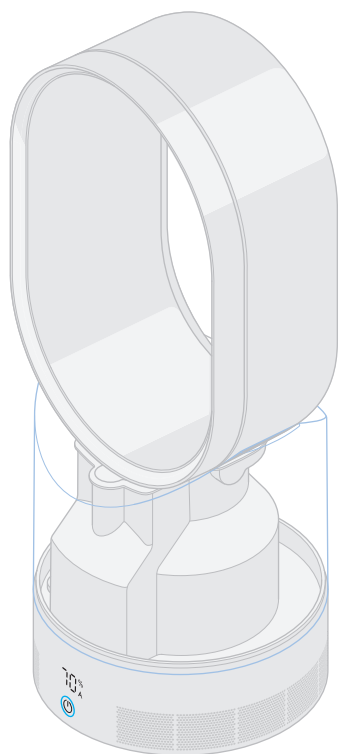



 % — Humidity percentage  
 A — Automatic Mode

 — On/off

Press and hold the power button on the appliance to adjust the humidity setting.

Blue light indicates that the AM10 is in humidity mode.

White light indicates that the AM10 is in fan mode.

## Refilling the tank

When animation sequence shows, the tank is empty.

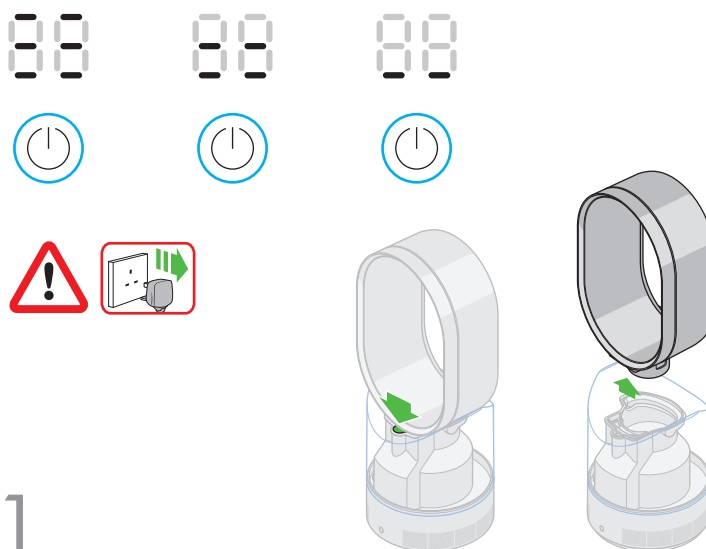

1

Unplug the appliance and push the button to unlock. Lift the loop amplifier away from tank, then tank away from base.

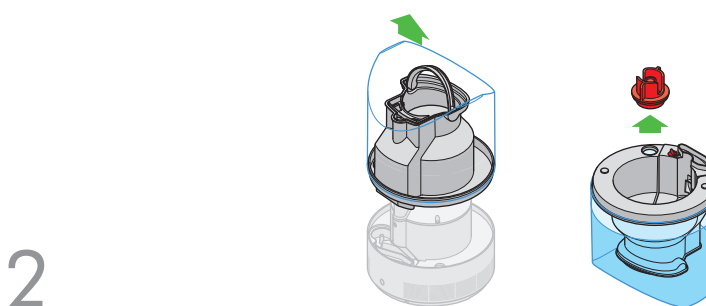

2

Remove the cap and fill tank (no other part) to the top with cold tap water. Replace the cap, tank and loop amplifier. Use the handle for easier handling.

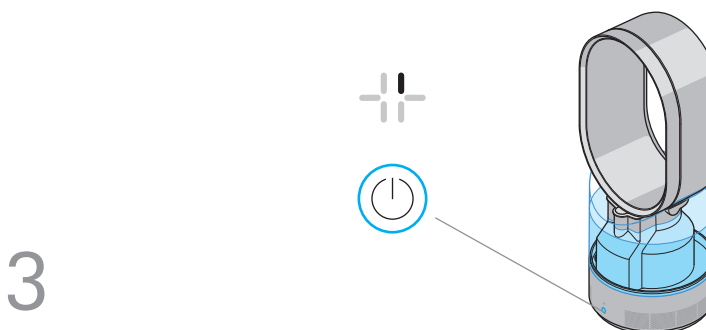

3

Switch 'ON': the water treatment procedure starts. After 3 minutes the appliance will start to humidify.

# Cleaning – important!

Cleaning procedures must be routinely followed to ensure that the humidifier continues to operate efficiently.

Cleaning regimes are designed to help prevent the build up of scale within the machine, which will be more prominent in hard water areas.

Failure to adhere to the cleaning regimes may invalidate the warranty.

Make your own cleaning solution

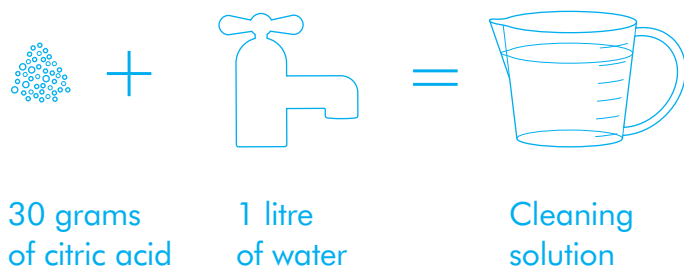

Other cleaning solutions are available. Please check these are suitable for use with plastics and then use in accordance with manufacturer's instructions. Examples of other suitable cleaning materials are descalers, foam soaps without an antibacterial agent, and vinegar.

Some cleaning chemicals are harmful to the appliance and should not be used. Use of these will invalidate your guarantee. Do not use: Alcohol and strong acid mixes, solvent (acetone) and oil based products, alkali bleach mixes, air fresheners, aroma oils, scented oils, hot water, brushes, abrasive materials, etc. Please do not put in a dishwasher or close to a fire.



# Once a week

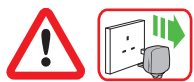

Turn the appliance into standby mode/'OFF'.  
Unplug from the mains electricity supply.

1

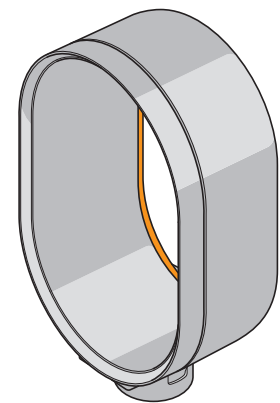

Wipe over air loop amplifier, paying close attention to the air gaps. Wipe with a lint-free microfibre cloth.

2

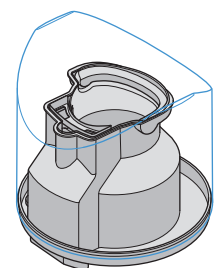

Empty the water. Rinse and wipe over all surfaces. Repeat if necessary.



3

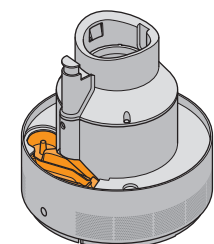

Empty the trough and wipe over all surfaces. Small spillages may occur. Do not rinse under the tap or put in the dishwasher. While not dangerous, care should be taken to avoid water entering the inlets. Wipe the exterior with a lint free microfibre cloth.

# Once a month (and before/after storage)

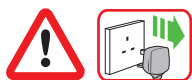

Turn the appliance into standby mode/'OFF'.  
Unplug from the mains electricity supply.



1

Unclip the loop amplifier surround: pull from the lower edge by hand, gently but firmly.

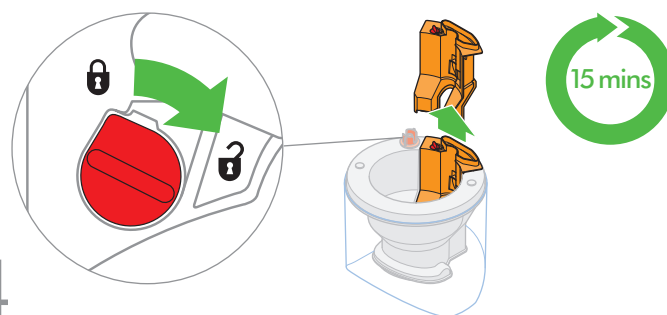

4

Empty the water tank. To release the water chimney, twist the dial a quarter of a turn. Lift out. Clean thoroughly by immersing in the citric acid solution for 15 minutes. Rinse and wipe over all surfaces. Repeat if necessary. Refit in reverse order, twisting the dial a quarter of a turn to secure.

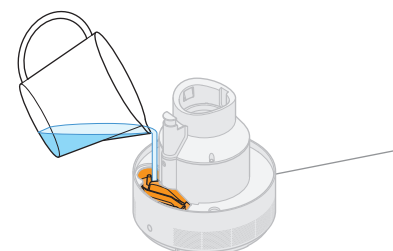
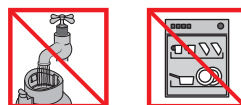

7

Empty the trough of any water, small spillages may occur. While not dangerous, care should be taken to avoid water entering the inlets. Clean thoroughly, using the recommended acid citric solution. Do not rinse under the tap or put in a

Some cleaning chemicals are harmful to the appliance and should not be used. Use of these will invalidate your guarantee. Do not use: Alcohol and strong acid mixes, solvent (acetone) and oil based products, alkali bleach mixes, air fresheners, aroma oils, scented oils, hot water, brushes, abrasive materials, etc. Please do not put in a dishwasher or close to a fire.

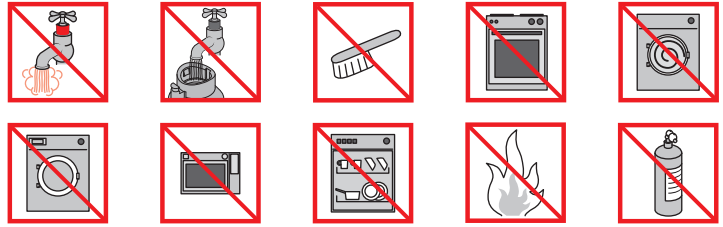

2

Using a damp cloth, wipe over both sections with the citric acid solution. Do not put in a dishwasher or rinse under the tap.

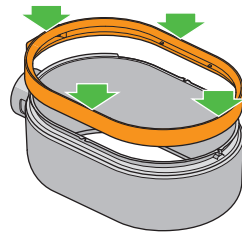

3

To attach the loop amplifier surround, lie flat and align the surround to the main amplifier. Push firmly until it clicks into place as shown.

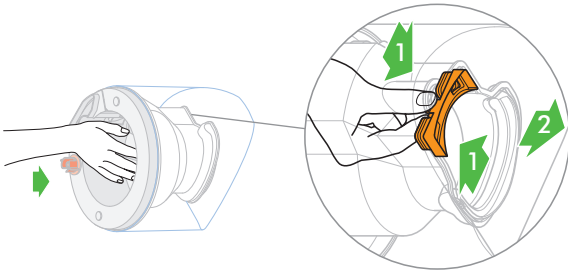

5

To remove the seal, pinch the securing tabs together and pull out. Clean thoroughly by immersing in the recommended citric acid solution for 15 minutes. Rinse and wipe over all surfaces. Repeat if necessary. To refit, push back in so the tabs click and the fit is secure.

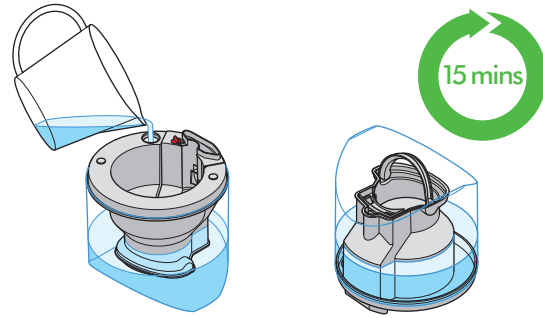

6

Pour in the recommended citric acid solution. Replace the cap and shake tank for 30 seconds. Then leave to stand. After 15 minutes, empty the tank. Rinse and wipe over all surfaces. Repeat if necessary.

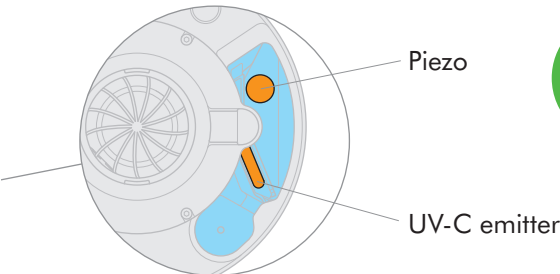

dishwasher. Fill the trough with the recommended acid citric solution until the UV-C emitter and piezo are submerged. Leave for 15 minutes. Drain, rinse and wipe over all surfaces. Repeat if necessary.

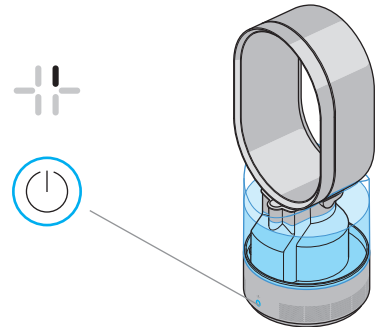

8

Re-assemble. Wipe the exterior with a lint-free microfibre cloth. Switch 'ON': the water treatment procedure starts. After 3 minutes the appliance will start to humidify.

# What do the lights mean?

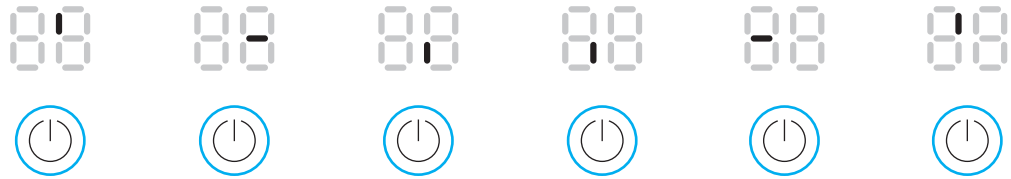

## Water treatment

The AM10 is treating the water. This takes 3 minutes.  
When the animation stops, the AM10 will start to humidify.

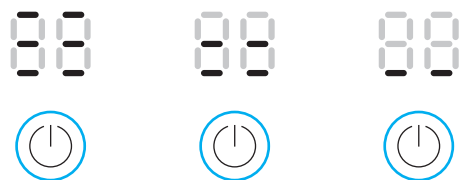

Tank is empty  
Switch 'OFF' and refill.

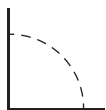
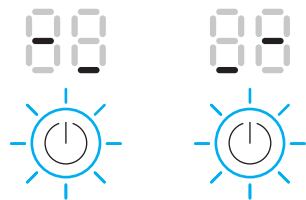

Tilted  
The base is not level.

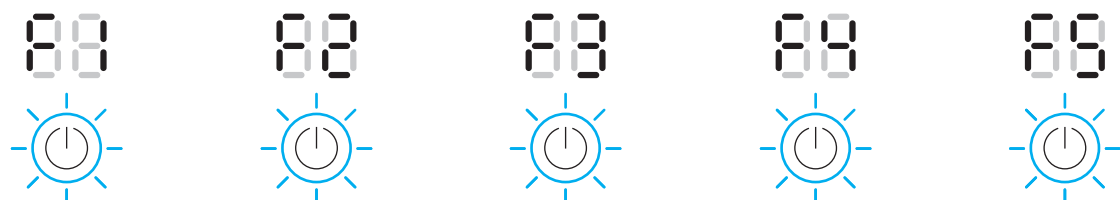

Please call the helpline.

Please call the helpline.

**AM10 is too cold.**  
Increase room temperature to 5°C or above.  
If the problem persists, contact the helpline.

Please call the helpline.

Please call the helpline.



If power button flashes 3 times when switching on, check that AM10 has been assembled correctly.



Blue light indicates that the AM10 is in humidity mode.



White light indicates that the AM10 is in fan mode.



# Using your humidifier

Please read the 'Important Safety Instructions' in this Dyson Operating Manual before proceeding.

## Introduction

- This is a cool mist, ultrasonic type of humidifier. Moist air is directed into the room from the loop amplifier.
- Water passes over a UV-C emitter to ensure that it is 99.9% bacteria-free before misting commences.

## Location

- Always place the appliance on a firm, flat, level surface.
- Do not place the appliance on a rug, carpet, wooden flooring, or any other surface that may be damaged by exposure to water or moisture.
- It is recommended that a waterproof mat or pad is placed under the appliance.
- Do not place the appliance underneath overhanging surfaces.
- Do not place the appliance in an area where it is accessible to children.
- Store the appliance indoors. Do not use or store it below 5°C (41°F). Ensure the appliance is at room temperature before operating.
- For the best performance, place on the floor, in the corner of the room, at least 1m from any wall and facing into the centre of the room.

## Operation

- All parts must be securely fitted before use.
- Do not use the appliance unless it has been cleaned according to instructions.
- In humidifier mode do not use without water in the tank.
- Do not lubricate any part of this appliance.
- When switched on, a small blue LED on the back of the appliance lights up to show that power is being received by the appliance. (Note: It does not mean that the appliance itself is operating.)
- Once the water treatment cycle completes the appliance is ready to begin humidification.

## Setting humidity level

- On first use, the display will show '70%', which is the highest relative humidity setting. The fan will run on lowest airspeed, '01'. For each use after this the appliance will remember the last target humidity level and airflow speed set.
- The appliance will not operate unless the target humidity setting is above the current room humidity level.
- The appliance will automatically adjust to avoid excessive humidity.
- Mist will be visible only in certain conditions (impacted by light, background colour, etc.) or at the lowest settings.

## Automatic Mode

- Press the AUTO button on the remote. This is the recommended mode of operation.
- The appliance selects a comfortable humidity for the room, based on environmental factors such as current humidity level and air temperature.
- When the room reaches the appropriate humidity level the

appliance will switch itself 'ON' or 'OFF' as necessary to maintain that level. The fan will remain running when the target humidity has been reached.

## Manual mode

- Select the desired humidity level (from 30% to 70%). When the room reaches the target humidity level the appliance will switch itself 'ON' or 'OFF' as necessary to maintain that level. The fan will remain running when the target humidity has been reached.

## Fan mode

- The fan mode button on the remote control turns the humidifier mode 'OFF'. Control the fan mode using the airflow and timer buttons.
- No water is needed for the fan mode.

## Control without the remote

- Press the power button on the appliance to turn ON/OFF.
- Press and hold the power button on the appliance to adjust the humidity setting.
- Fan mode and the sleep timer cannot be operated without the remote control.
- The air speed setting automatically sets to '05'.

## Refilling

- When refilling, empty the tank completely (preferably washing and drying it), then refill – this keeps the water fresh.
- With a full tank of cold tap water (3 litres) the appliance will run for at least 10 hours, depending on the target humidity setting and other environmental conditions. Do not add anything to the water (such as scents, oils etc).

## Cleaning the base

- Small water spillages may occur. While the amount of water in the trough is not significant enough to damage the appliance, significant care should be taken when emptying it. Ensure that water does not enter through the inlets of the appliance. If some water does pass through the inlets, dry the exterior with a cloth and continue to use as normal.

## Cleaning the tank

- Pour in the recommended citric acid solution. Replace the cap and shake tank for 30 seconds. Then leave to stand. After 15 minutes, empty the tank. Rinse and wipe over all surfaces. Repeat if necessary.

## Storage

- When not in use, unplug from the mains electricity supply.
- Store the appliance in a dry location and arrange the cable away from traffic areas so that it will not be tripped over or damaged.
- Clean the appliance and tank as instructed before storing and before re-use.

## Battery replacement

### CAUTION

- Unscrew the battery compartment on the remote control. Loosen the base and pull to remove the battery.
- Do not install backwards or short circuit the batteries.
- Do not attempt to dismantle or charge the batteries. Keep away from fire.
- Follow battery manufacturers' instructions when installing new batteries (battery type CR 2032).
- Limited functionality is available without the remote control (see 'Control without the remote').

### Automatic cut-out

- If the appliance is tilted by over 5° the display will show a 'tilted' graphic. If after 15 minutes the appliance is not levelled it will switch 'OFF'.
- If the appliance has been tilted make sure it is level and clear up any spillage.

### Troubleshooting

- Do not carry out any maintenance or repair work other than that shown in this Dyson Operating Manual, or advised by the Dyson Helpline.
- An F3 failure message means the appliance is too cold. The appliance will operate when it is above 5°C (41°F). If other failure messages are displayed, contact the Dyson Helpline.
- If the UV-C emitter is exposed for any reason the appliance will switch 'OFF'.
- If the piezo or UV-C emitter needs to be replaced, contact the Dyson Helpline.

### DISPOSAL INFORMATION

- Dyson products are made from high grade recyclable materials. Recycle where possible.
- The battery should be removed from the product before disposal.
- Dispose of or recycle the battery in accordance with local ordinances or regulations.



This marking indicates that this product should not be disposed with other household wastes throughout the EU. To prevent possible harm to the environment or human health from uncontrolled waste disposal, recycle it responsibly to promote the sustainable reuse of material resources. To return your used device, please use the return and collection systems or contact the retailer where the product was purchased. They can take this product for environmentally safe recycling.

### Dyson customer care

Thank you for choosing to buy a Dyson appliance  
After registering your free 2 year guarantee, your Dyson appliance will be covered for parts and labour for 2 years from the date of purchase, subject to the terms of the guarantee. If you have any questions about your Dyson appliance, call the Dyson Helpline with your serial number and details of where/when you bought the appliance.  
Most questions can be solved over the phone by one of our trained Dyson Helpline staff.  
Alternatively, visit [www.dyson.co.uk/support](http://www.dyson.co.uk/support) (UK) or [www.dyson.ie/support](http://www.dyson.ie/support) (ROI) for online help, general tips and useful information about Dyson.

Your serial number can be found on your rating plate which is on the base of the appliance.

If your Dyson appliance needs a service, call the Dyson Helpline so we can discuss the available options. If your Dyson appliance is under guarantee, and the repair is covered, it will be repaired at no cost.

### PLEASE REGISTER AS A DYSON APPLIANCE OWNER

To help us ensure you receive prompt and efficient service, please register as a Dyson appliance owner. There are three ways to do this:

- Online at [www.dyson.co.uk/register](http://www.dyson.co.uk/register) (UK) or [www.dyson.ie/register](http://www.dyson.ie/register) (ROI).

- Telephone the Dyson Helpline on 0800 298 0298 (UK) or 01 475 7109 (ROI).

- Complete the enclosed form and post it to us.

This will confirm ownership of your Dyson appliance in the event of an insurance loss, and enable us to contact you if necessary.

### LIMITED 2 YEAR GUARANTEE

#### TERMS AND CONDITIONS OF THE DYSON 2 YEAR LIMITED GUARANTEE

#### WHAT IS COVERED

- The repair or replacement of your Dyson appliance (at Dyson's discretion) if it is found to be defective due to faulty materials, workmanship or function within 2 years of purchase or delivery (if any part is no longer available or out of manufacture Dyson will replace it with a functional replacement part).
- Where this machine is sold outside of the EU, this warranty will only be valid if the appliance is used in the country in which it was sold.
- Where this machine is sold within the EU, this warranty will only be valid (i) if the appliance is used in the country in which it was sold or (ii) if the appliance is used in Austria, Belgium, France, Germany, Ireland, Italy, Netherlands, Spain or the United Kingdom and the same model as this appliance is sold at the same voltage rating in the relevant country.

#### WHAT IS NOT COVERED

Dyson does not guarantee the repair or replacement of a product where a defect is the result of:

- Accidental damage, faults caused by negligent use or care, misuse, neglect, carelessness or operation or handling of the appliance which is not in accordance with the Dyson Operating Manual.
- Use of the appliance for anything other than normal domestic household purposes.
- Use of parts not assembled or installed in accordance with the instructions of Dyson.
- Use of parts and accessories which are not genuine Dyson components.
- Faulty installation (except where installed by Dyson).
- Repairs or alterations carried out by parties other than Dyson or its authorised agents.
- Normal wear and tear (e.g. fuse, brush bar etc.).

If you are in any doubt as to what is covered by your guarantee, please contact the Dyson Helpline.

#### Summary of cover

- The guarantee becomes effective at the date of purchase (or the date of delivery if this is later).
- You must provide proof of (both the original and any subsequent) delivery/purchase before any work can be carried out on your Dyson appliance. Without this proof, any work carried out will be chargeable. Keep your receipt or delivery note.
- All work will be carried out by Dyson or its authorised agents.
- Any parts which are replaced by Dyson will become the property of Dyson.
- The repair or replacement of your Dyson appliance under guarantee will not extend the period of guarantee.
- The guarantee provides benefits which are additional to and do not affect your statutory rights as a consumer.

#### ABOUT YOUR PRIVACY

- Your information will be held by Dyson and its agents for promotional, marketing and servicing purposes.
- If your personal details change, if you change your mind about any of your marketing preferences or if you have any queries about how we use your information, please contact the Dyson Helpline.
- For more information on how we protect your privacy, please see our privacy policy on the Dyson website.











# GUARANTEE FORM

Serial number

Date of purchase	□□ / □□ / □□	Country of purchase	□ UK	□ ROI	
Title		Surname			
First name					
Address					
Postcode					
email					
Telephone			Mobile		

As a Dyson fan owner, you can hear about Dyson inventions, services and products before anyone else. If it's okay to contact you, please let us know how we may do this.

By mail	Yes <input type="checkbox"/>	No <input type="checkbox"/>		Yes <input type="checkbox"/>	No <input type="checkbox"/>
By phone	Yes <input type="checkbox"/>	No <input type="checkbox"/>		Yes <input type="checkbox"/>	No <input type="checkbox"/>
By email	Yes <input type="checkbox"/>	No <input type="checkbox"/>		Yes <input type="checkbox"/>	No <input type="checkbox"/>
By text message	Yes <input type="checkbox"/>	No <input type="checkbox"/>		Yes <input type="checkbox"/>	No <input type="checkbox"/>

We sometimes ask other companies (such as market researchers) to contact owners on our behalf. We do this to get feedback on ideas or ask you to try new products and services. Would this be okay?

## 3 EASY WAYS TO REGISTER YOUR FREE 2 YEAR GUARANTEE

**Register online**

Visit our website to register your full parts and labour guarantee online.

**[www.dyson.co.uk/register](http://www.dyson.co.uk/register)**  
**[www.dyson.ie/register](http://www.dyson.ie/register)**

**Register by phone**

Call our dedicated Helpline.  
 Open Monday to Friday 8am-8pm & Saturday and Sunday 8am-6pm.

**UK: 0800 298 0298**  
**ROI: 01 475 7109**

**Register by mail**

Complete and return the form to Dyson in the envelope supplied.

