

# 2 Door 1 Drawer Sideboard

Assembly Instructions - Please keep for future reference

041 xx 6005

459/1113

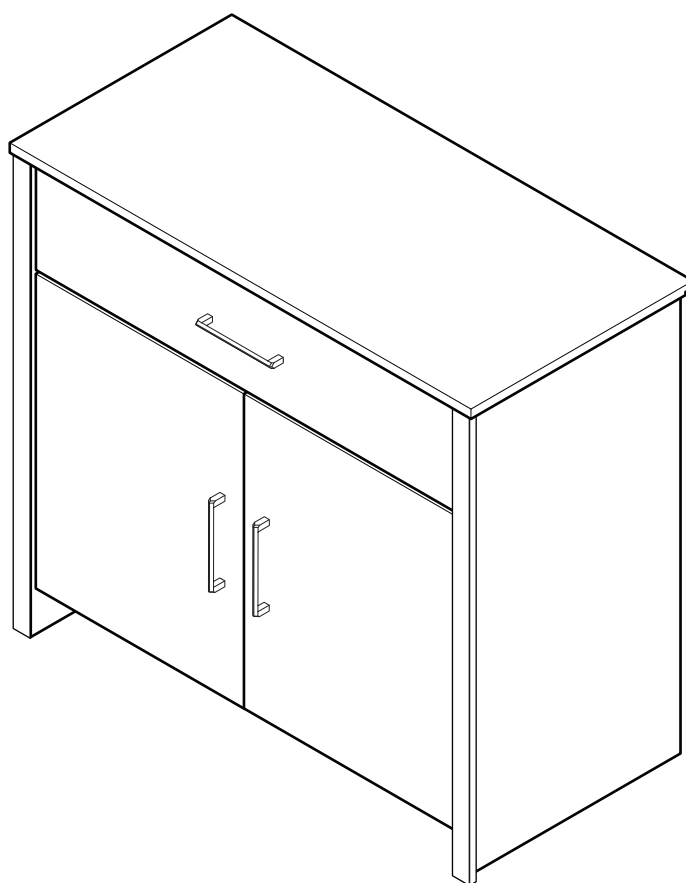

## Dimensions

Width - 80.6cm

Depth - 38.8cm

Height - 73.6cm

**Important** - Please read these instructions fully before starting assembly

If you need help or have damaged or missing parts, call the **Customer Helpline: 01709534123**  
Please turn to back page for important information when contacting Customer Helpline.



# Safety and Care Advice

**Important - Please read these instructions fully before starting assembly**

- Check you have all the components and tools listed on pages 2 and 3.
- Remove all fittings from the plastic bags and separate them into their groups.
- Keep children and animals away from the work area, small parts could choke if swallowed.
- Make sure you have enough space to layout the parts before starting.

- Do not stand or put weight on the product, this could cause damage.
- Assemble the item as close to its final position (in the same room) as possible.
- Assemble on a soft level surface to avoid damaging the unit or your floor.
- Parts of the assembly will be easier with 2 people.



• We do not recommend the use of power drill/drivers **for inserting screws**, as this could damage the unit. Only use hand screwdrivers.

• **Do Not dispose of packaging until assembly complete.**

• Dispose of all packaging carefully and responsibly when assembly complete.

## Care and maintenance

- To protect the furniture, position the furniture out of direct sunlight and away from direct heat sources such as radiators and fires.
- Do not place the furniture in excessively dry and humid conditions.
- From time to time check that there are no loose screws on this unit.
- Always lift furniture when moving it (do not drag) otherwise the joints may be damaged.

- Do not place hot or cold objects on the surface, always use protective mats to avoid marking the furniture.
- This product should not be discarded with household waste. Take to your local authority waste disposal centre.
- Clean spills up immediately
- Dust surfaces with a soft, dry, lint free cloth.

- More stubborn marks can be removed using a damp (not wet) cloth. Wipe the surface dry immediately using a soft lint free cloth.
- Do not use detergents, abrasive cleaning products or cleaning products that contain ammonia, solvents or silicone as these may damage the surface finish.

# Components - Panels

Please check you have all the panels listed below



**Important** - Thick lines indicate finished edges

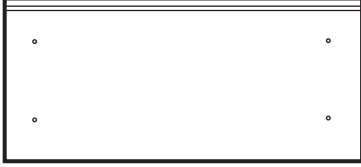

**0008** Top (80.6x38.8cm)



**0009** Bottom (73.6x35.2cm)

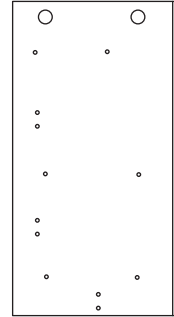

**0010**  
Left End Panel  
(72x38.2m)

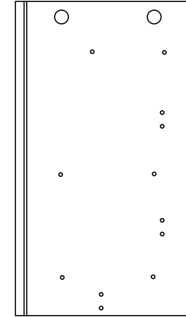

**0011**  
Right End Panel  
(72x38.2cm)



**8817** Plinth (73.6x76cm)



**0014** Shelf (73.6x33.0cm)



**9321**  
Drawer Bottom  
(71.4x29.8cm)



**8822**  
Backpanel  
(74.6x64.4cm)

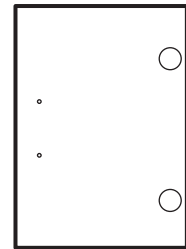

**0013**  
Door x 2  
(47.6x36.5cm)

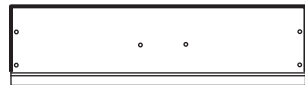

**0012**  
Draw Front  
(73.2x15.7cm)

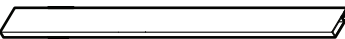

**684xx2561**  
Trim x 2  
(720x50x12cm)

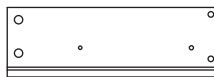

**622xx7006**  
Left drawer side (30x12cm)

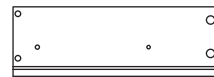

**623xx7006**  
Right drawer side (30x12cm)

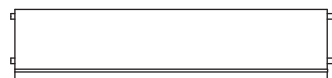

**624xx7028**  
Drawer back (70.3x12cm)













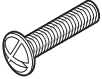

# Components-Fittings

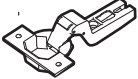
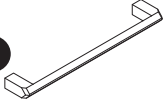
If you have damaged or missing components, call the **Customer Helpline: 01709 534123** Please turn to back page for important information when contacting Customer Helpline.

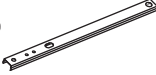
Please check you have all the fittings listed below

**Note:** The quantities below are the correct amount to complete the assembly, In some case more fittings may be supplied than are required.

<b>A</b>  Large cam x 12 Code 760001103	<b>B</b>  Metal dowel x 16 Code 760003004	<b>C</b>  Small cam x 4 Code 760003005
<b>D</b>  18mm bolt x 6 Code 700002021	<b>E</b>  Panel pin x 8 Code 760001012	<b>F</b>  12mm screw x 8 Code 690001008
<b>G</b>  Hingeplate x 4 Code 653006000	<b>H</b>  Hinge x 4 Code 652001120	<b>I</b>  Handle x 3 Code 644003511
<b>J</b>  Panel Pin Locator Code 684004501	<b>K</b>  Runner x 2 Code 760001040	<b>L</b>  Panel Holder x 3 Code 680003505
<b>M</b>  8mm screw x 4 Code 700003510	<b>N</b>  9mm bolt x 2 Code 690001078	<b>P</b>  Shelf stud x 4 Code 681003001

## Tools required

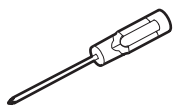

Cross headed screwdriver (small)



Tape Measure



Drill



Small Hammer

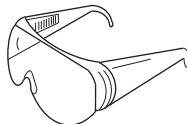

Eye protection (when using a hammer)

Ruler - Use this ruler to help correctly identify the screws

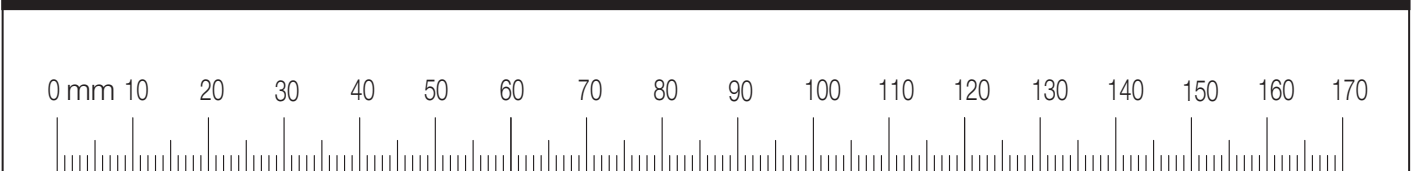

# Exploded View

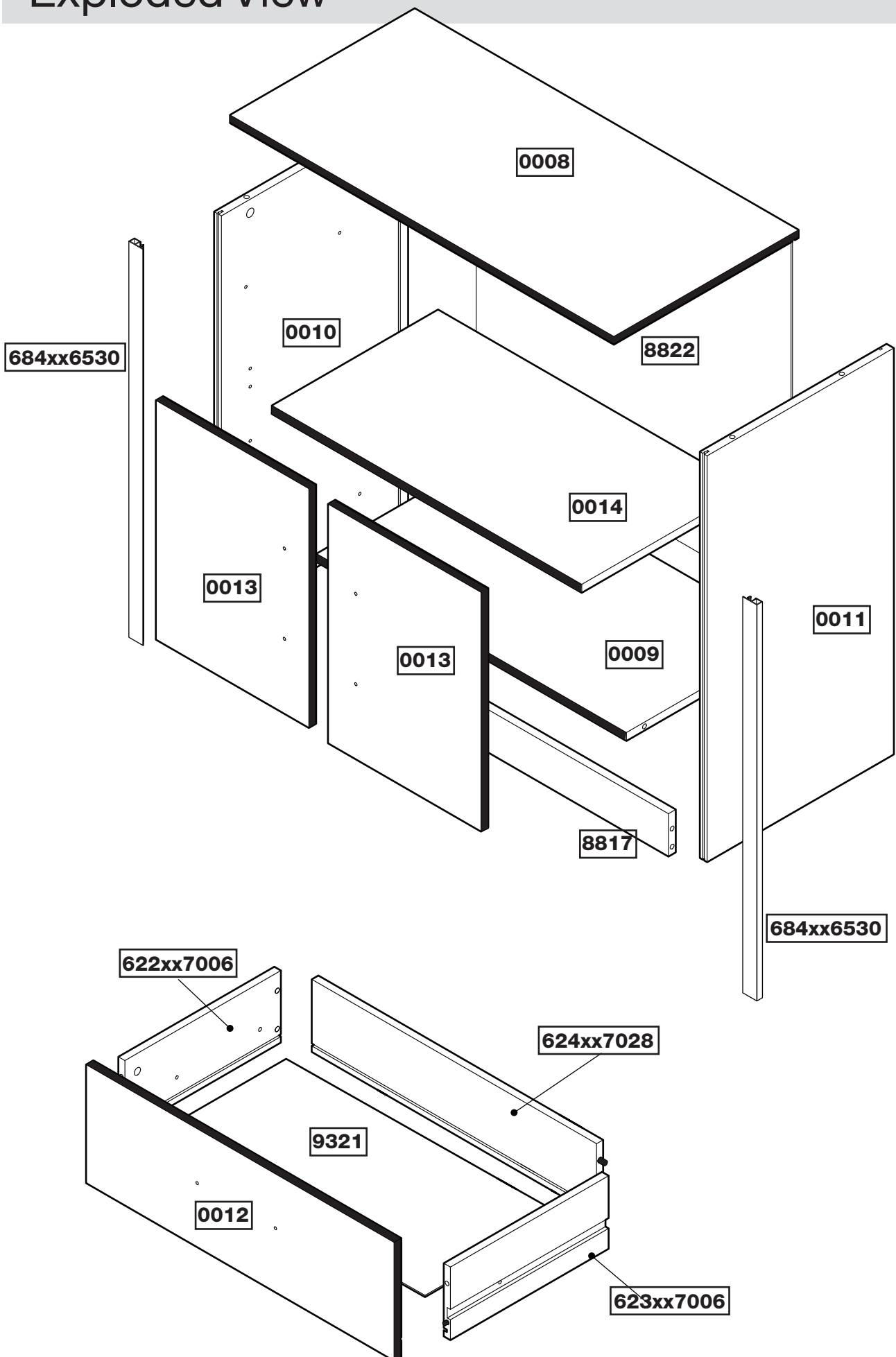

# Assembly Instructions

## Step 1

### Fitting dowels to top panel.

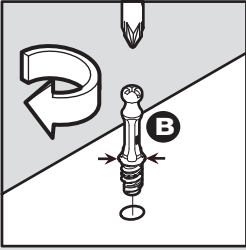

**Note:** Insert metal dowels **B** as far as shown by arrows. **Do not over tighten.**

Fittings you will need for this step:

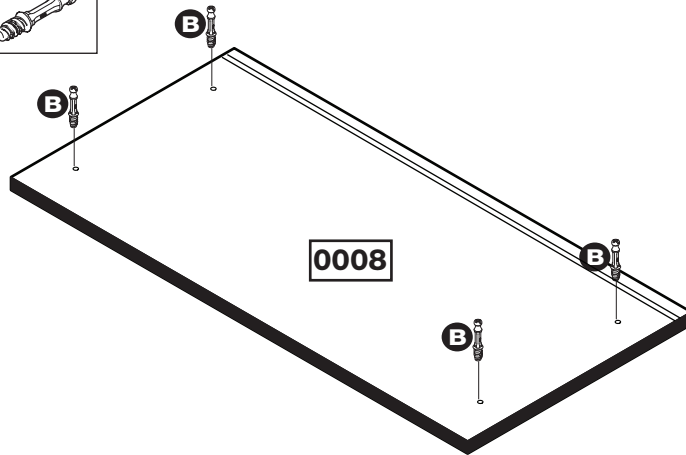
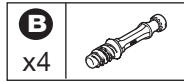

## Step 2

### Fitting cams to the bottom panel

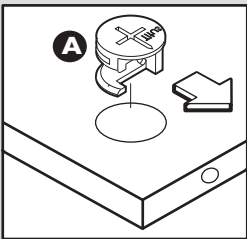

**Note:** Ensure cam arrow points towards the edge with hole.

Fittings you will need for this step:

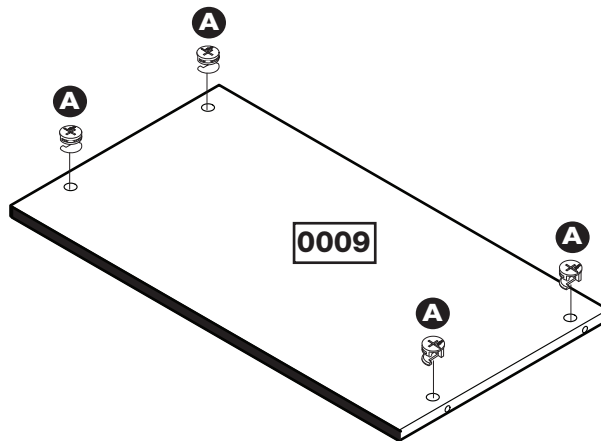
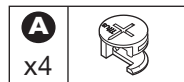

## Step 3

### Fitting cams to the plinth panel.

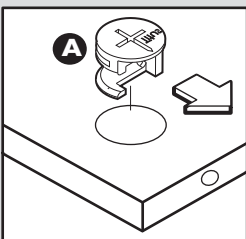

**Note:** Ensure cam arrow points towards the edge with hole.

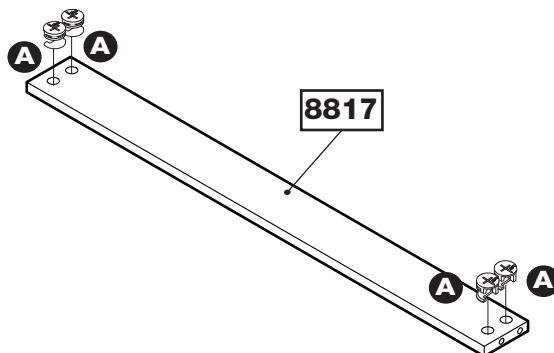
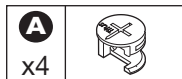

# Assembly Instructions

## Step 4

**Fitting hingeplates, cams & dowels to the left end panel.**

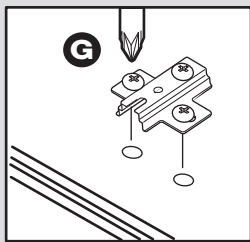

Ensure that the hinge points towards the grooved edge of the panel.

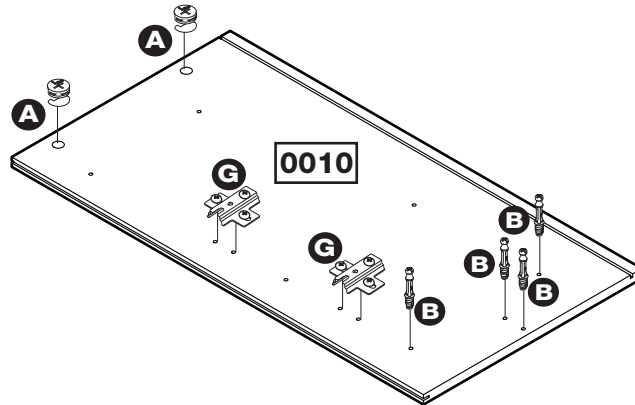

**Fitting cams & dowels to the right end.**

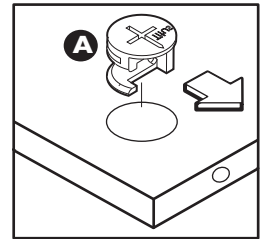

**Note:** Ensure cam arrow points towards the edge with hole.

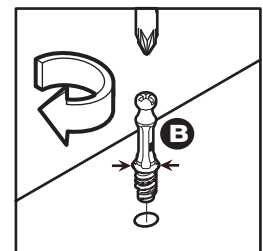

**Note:** Insert metal dowels **B** as far as shown by arrows. **Do not over tighten.**

## Step 5

**Attaching runner to left end**

Position the runner so that the second hole from the front of the runner lines up with the pre-drilled hole nearest to the edge of the panel. Use screws **M** to secure the runner.

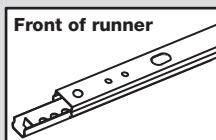

Slide the runner forward revealing the back of the runner. The second hole to the back of the runner should now line up with the second pre-drilled hole.

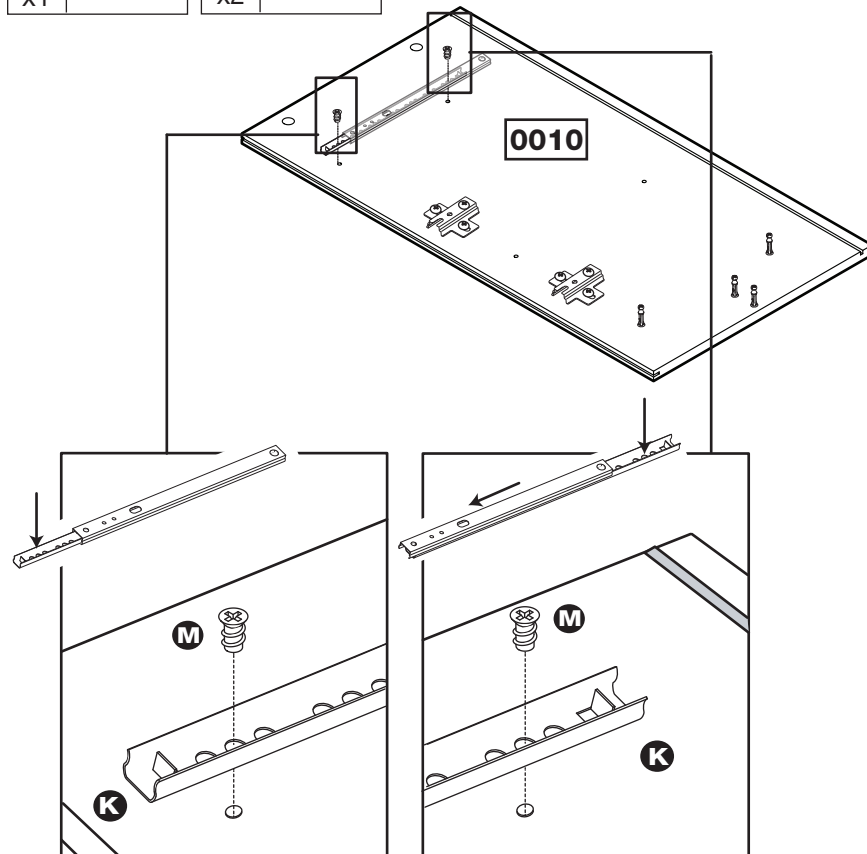

# Assembly Instructions

## Step 6

Fitting hingeplates, cams & dowels to the left end panel.

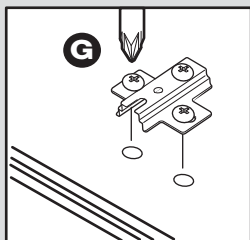

Ensure that the hinge points towards the grooved edge of the panel.

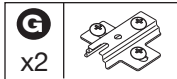
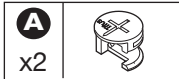
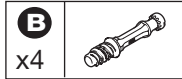

Fitting cams & dowels to the right end.

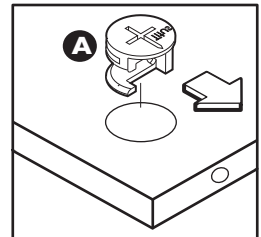

**Note:** Ensure cam arrow points towards the edge with hole.

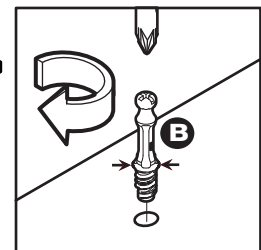
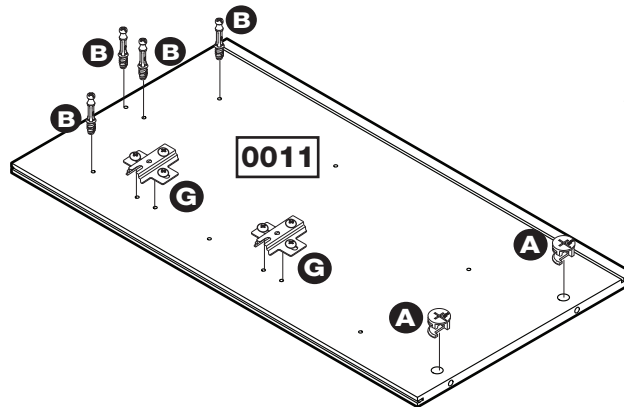

**Note:** Insert metal dowels **B** as far as shown by arrows. **Do not over tighten.**

## Step 7

Attaching runner to right end

Position the runner so that the second hole from the front of the runner lines up with the pre-drilled hole nearest to the edge of the panel. Use screws **M** to secure the runner.

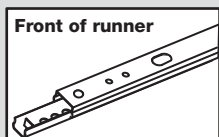

Slide the runner forward revealing the back of the runner. The second hole to the back of the runner should now line up with the second pre-drilled hole.

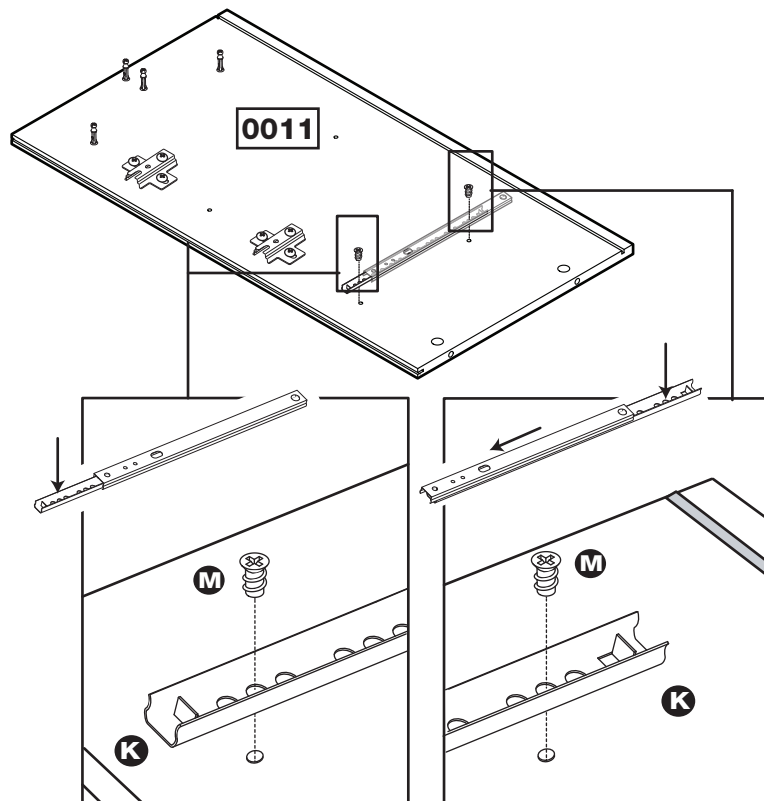
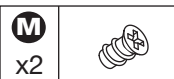



# Assembly Instructions

## Step 8

### Attach hinges and handles to doors



**Important:**  
**a:** Insert hinges **H** into holes, ensure the hinge is straight (90 degree angle).

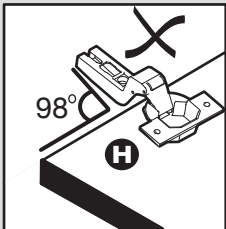
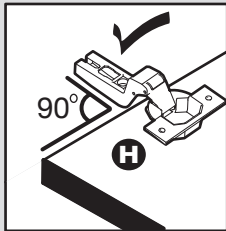

**b:** Before securing the hinges **H**, we recommend you pre - mark the doors using a bradawl.

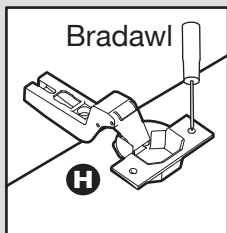

**c:** Secure hinges **H** to doors using screws **F**.

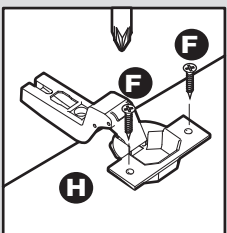

**d:** Secure handle **I** to doors using bolts **D**.  
Repeat on remaining door

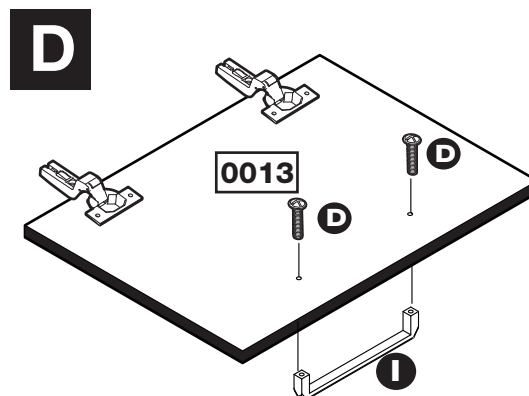
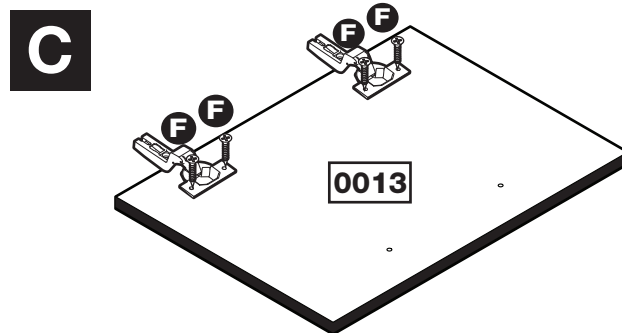
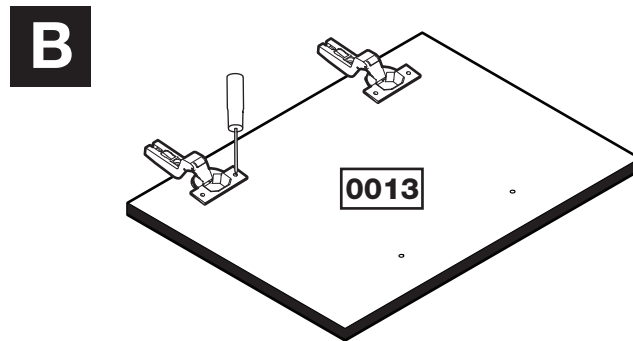
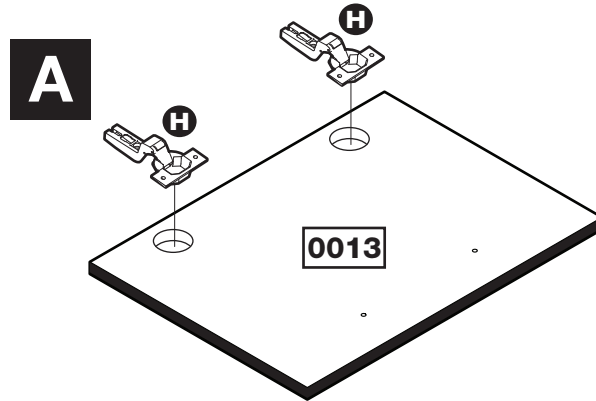

# Assembly Instructions

## Step 9

### Fitting dowels to the drawer front.

**A:** Insert 4 metal dowels **B** into the the drawer front **0012** .

**B:** Insert small cams into left **622xx7006** and right **623xx7006** drawer sides.

**Note:** Ensure cam arrow points towards the edge with hole.

**C:** Insert wooden dowels in drawer back **624xx7028** into holes in left **622xx7006** right **623xx7006** hand drawer sides.

**D:** Slide drawer bottom into grooves in the left and right drawer sides and the drawer back.



**A**

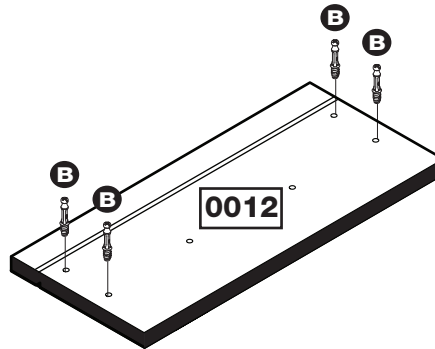

**NOTE:**

The drawers have been reduced in size for the purposes of illustration.

**B**

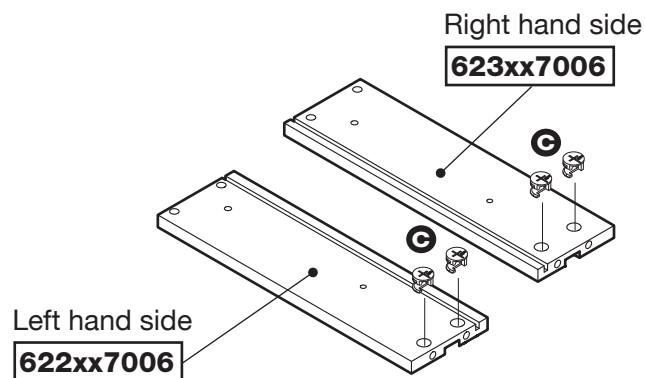

**C**

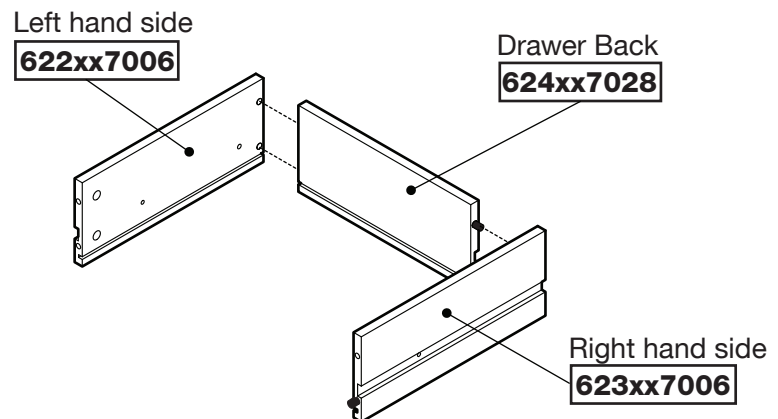

**D**

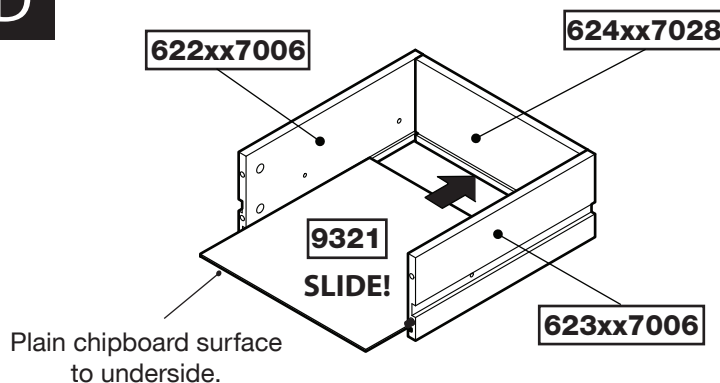

# Assembly Instructions

## Step 9 - Continued

**E:** Locate the metal dowels (already inserted) in the drawer front into the small cams in the left and right hand drawer sides.

Turn the cam 180 degrees to lock.

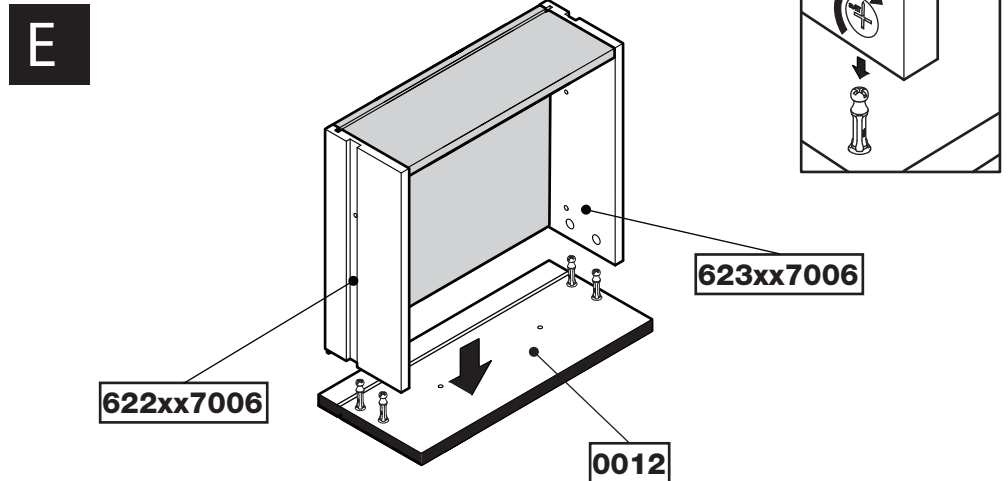

**F:** Fit 2 bolts **D** through the pre-drilled holes in the drawer front **0012** and connect to the handle **I**.

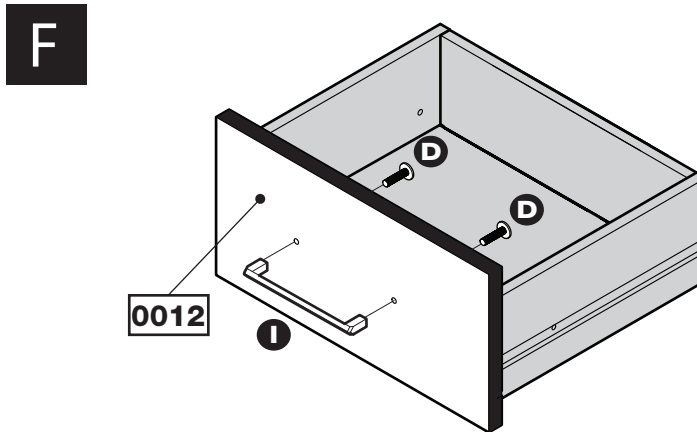

## Step 10

**Connect left end panel to bottom.**

Connect the dowels in the left end panel **0010** into the cams in the bottom **0009**

Turn cams 180° to lock.

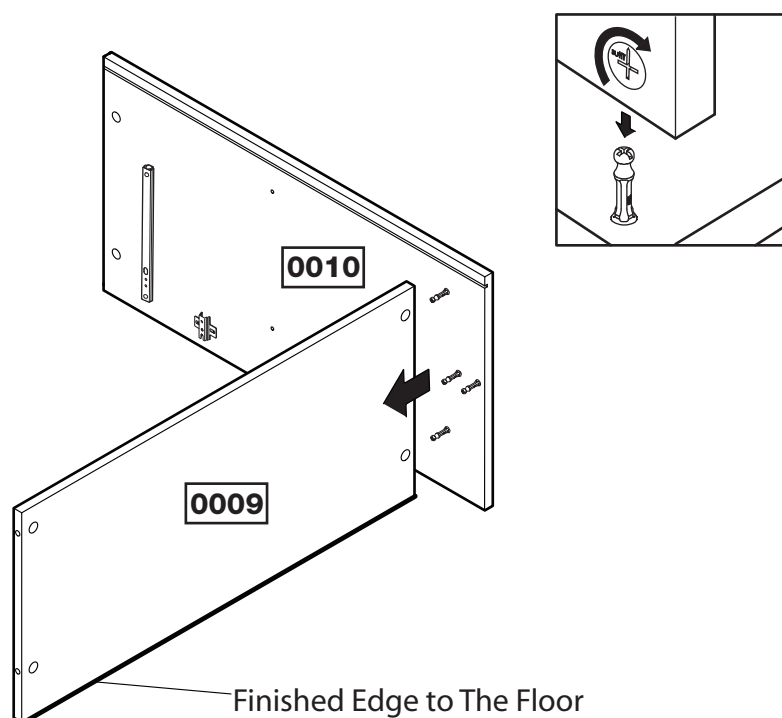

# Assembly Instructions

## Step 11

### Connect left end panel to plinth.

Connect the dowels in the left end panel into the cams in the plinth **8817**

Turn cams 180° to lock.

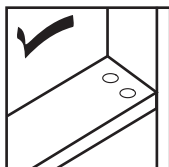

Ensure plinth sits flush.

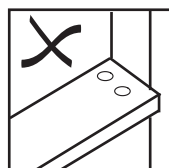

Ensure plinth is not overhanging.

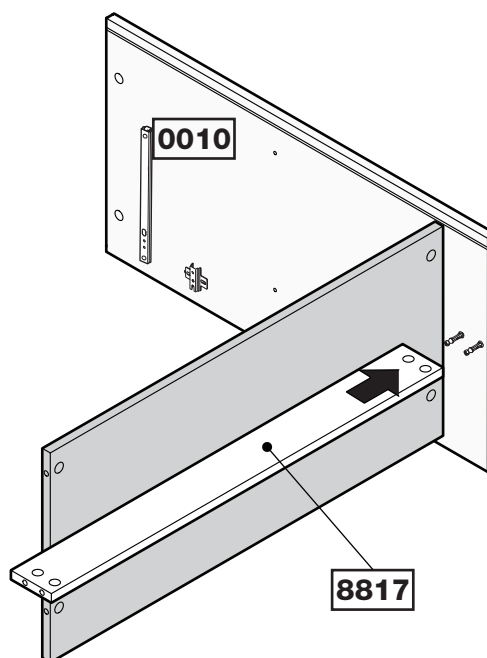

## Step 12

### Connect right end panel to bottom and plinth.

Connect right hand end panel **0011** to bottom **0009** and plinth **8817**

Turn cams 180° to lock.

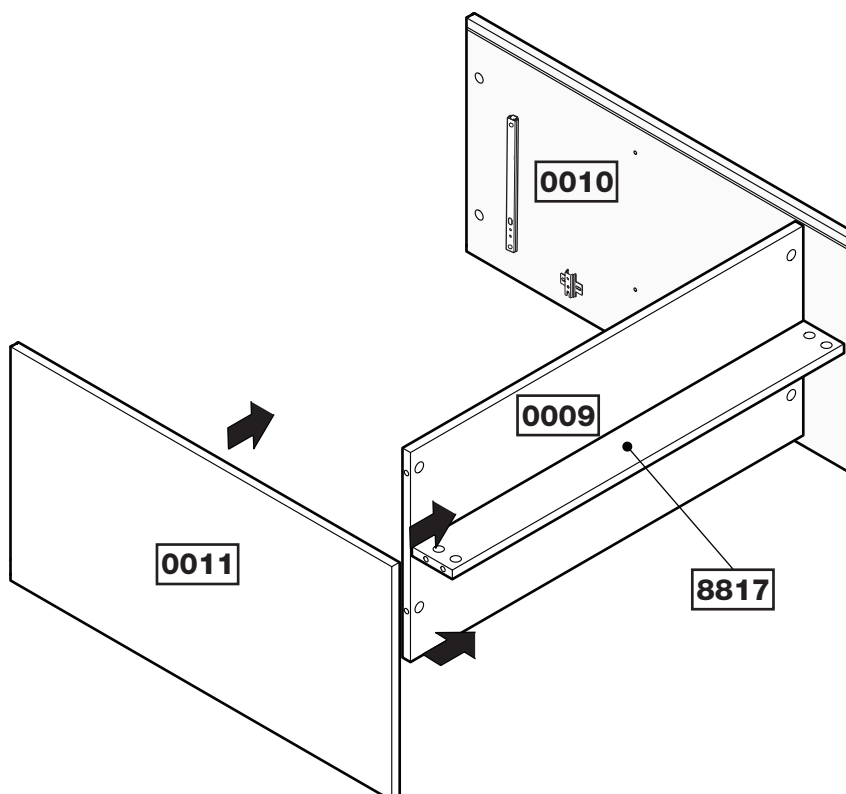

# Assembly Instructions

## Step 13

### Connect the top panel to the ends .

Connect the dowels in the top panel **0008** to end panels **0010** and **0011** .

Turn cams 180° to lock.

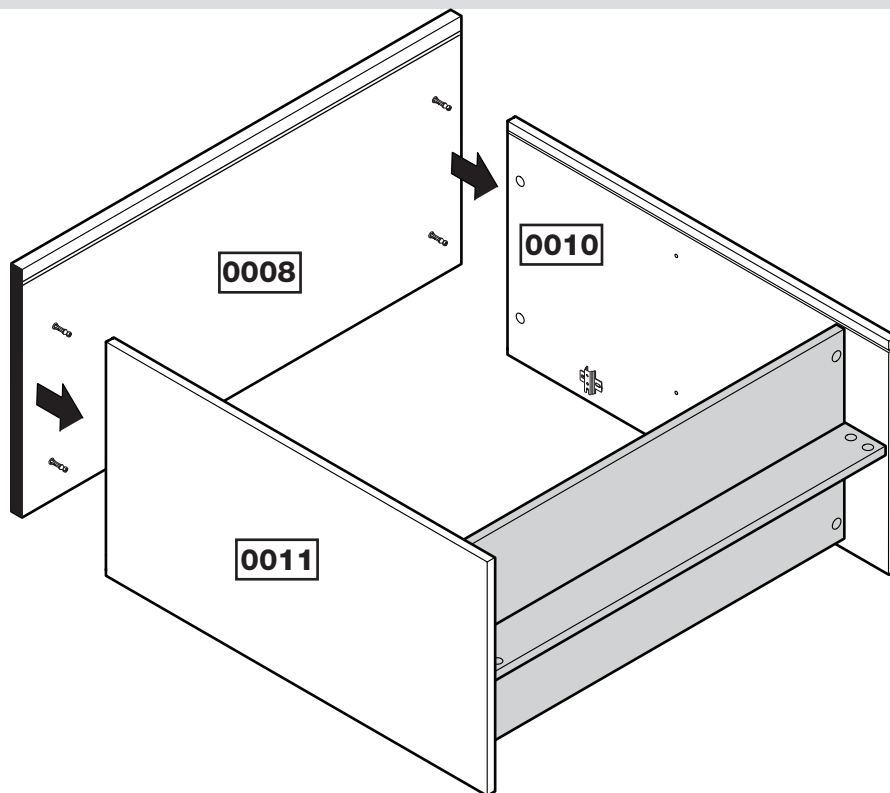

## Step 14

Slide the back panel **8822** into the grooves.

You may need to tilt the unit onto it's top to ensure that the back panel is located into the groove.

### Squaring up the unit.

#### Important:

 Ensure a **tape measure** is used to **square up** unit!

Before securing the back it is necessary to square up the unit.

You can do this by measuring between XX - XX and YY - YY ensuring these are the same (DIAG 1).

If they are not (DIAG 2) Apply slight pressure as indicated (DIAG 3) until they are the same.

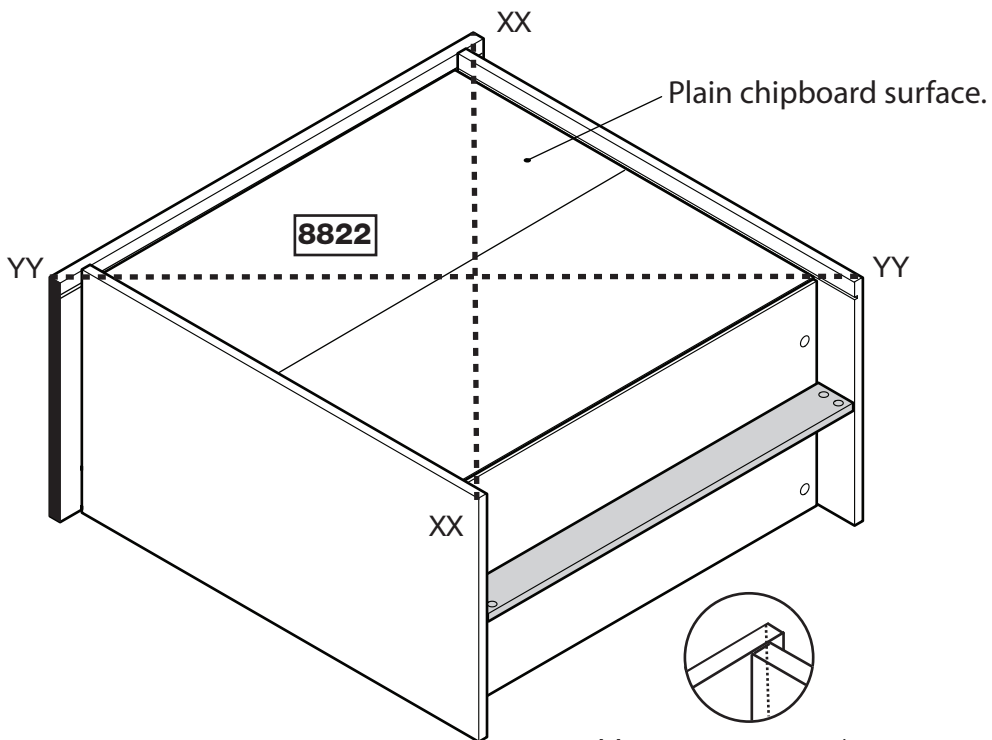
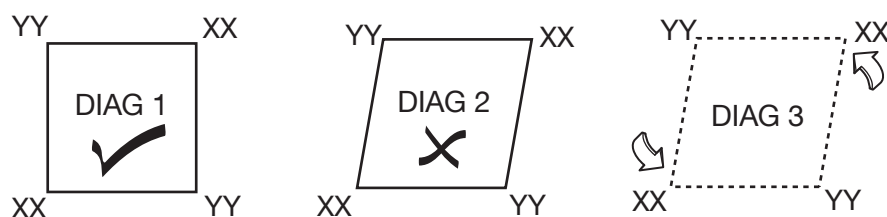

Measure to external corners

# Assembly Instructions

## Step 15

### Attach backpanel to bottom

Use the panel pin guide when locating the panel pins. This will hold the panel pins vertical and ensure the correct distance from the edge.

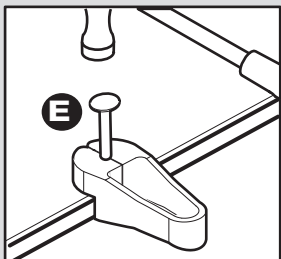

Ensure that the backpanel is fully inserted into groove.

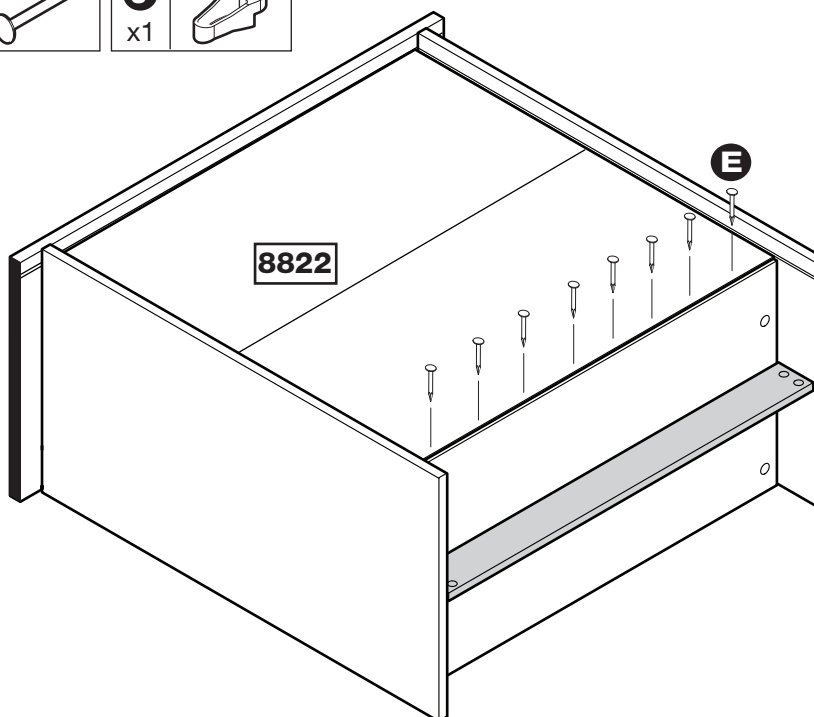

## Step 16

### Add stability blocks.

Slide the thin point of the stability blocks **L** between the back panel **8822** and the grooves.

Once inserted fully, tighten the screws in the stability blocks.

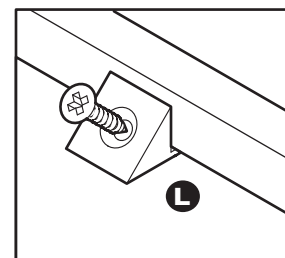
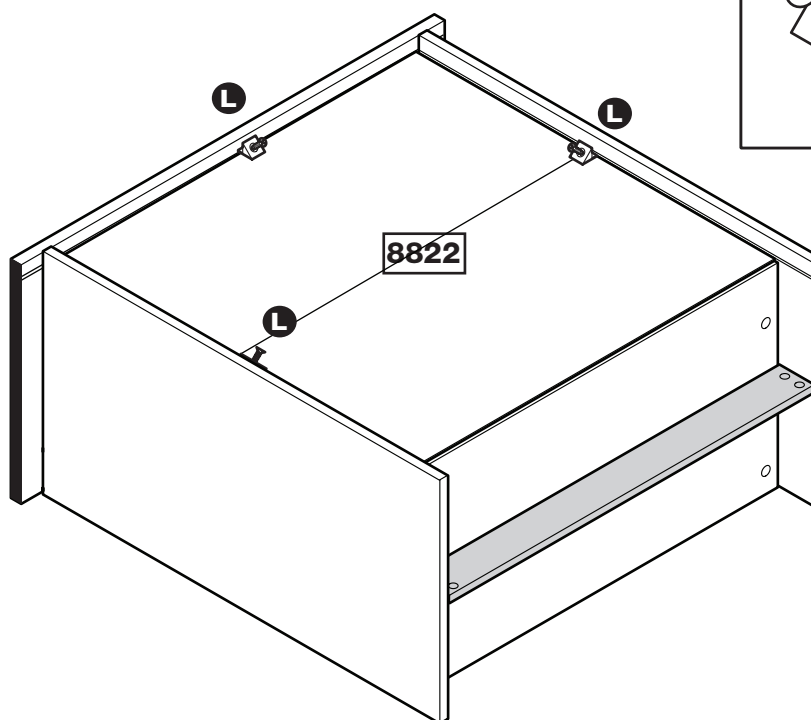

# Assembly Instructions

## Step 17

### Attach silver trim

Turn unit over.  
Remove protective film from silver trim.



**Warning:**  
2 people to lift.  
Lift with care.

Locate the notch on silver trim into groove on left **0010** and right **0011** ends.

Ensure the silver trims are positioned correctly.

To insert silver trims use a hammer, place a cardboard packing piece between the hammer and silver trims to protect the silver trims.

Fittings you will need for this step:

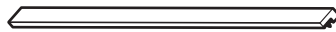

Silver Trims  
(x2)

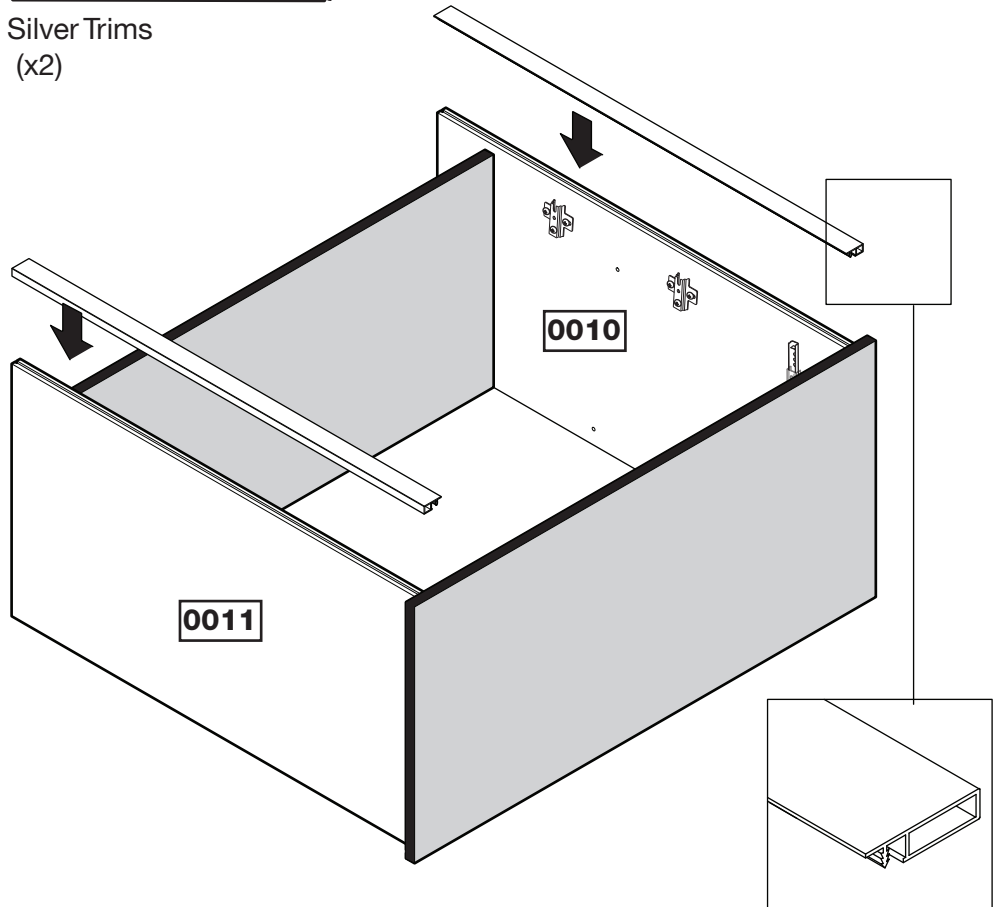

## Step 18

### Lift unit up and Locate shelf studs



**Warning:**  
2 people to lift.  
Lift with care.

Push shelf studs **P** into panels **0010** and **0011**.

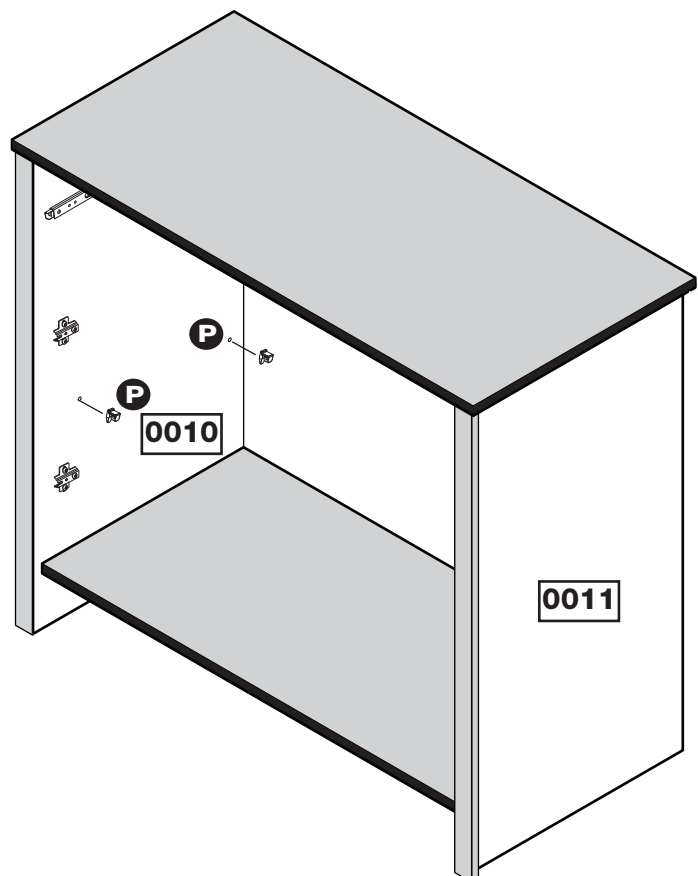
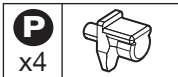
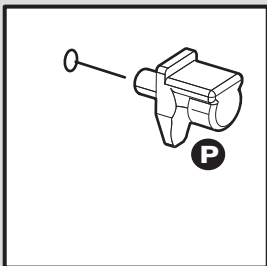

# Assembly Instructions

## Step 19

### Locate shelf onto shelf studs

Locate shelf **0014**  
onto shelf studs **P**

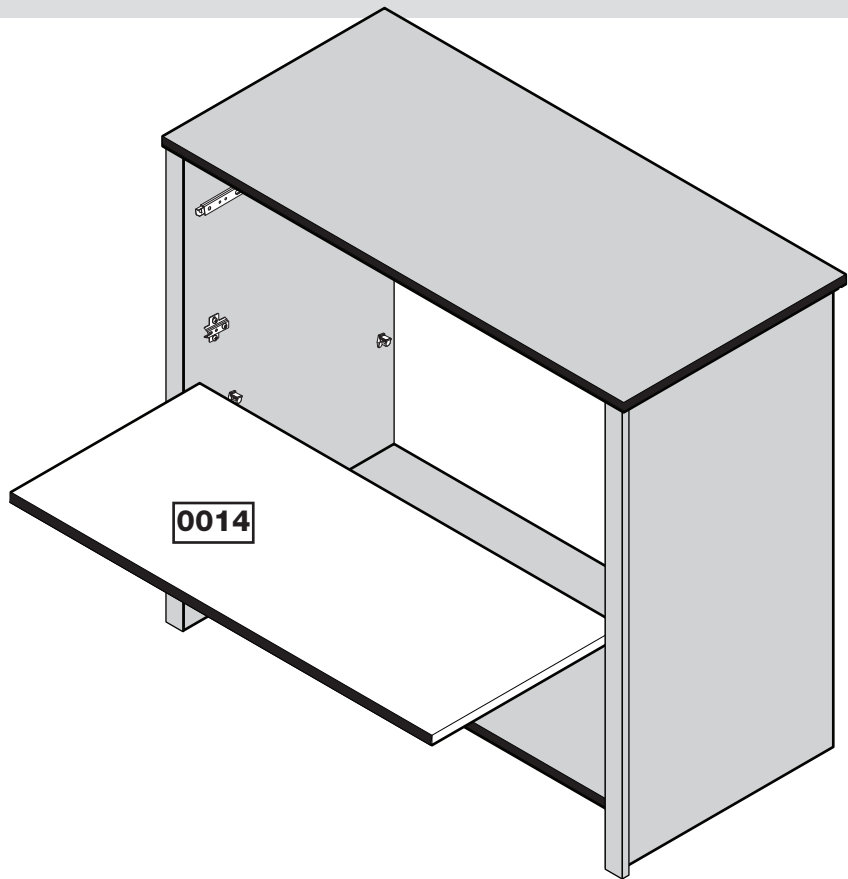

## Step 20

### Locate drawer

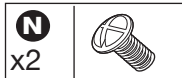

For this step we recommend you follow the helpful hints page.

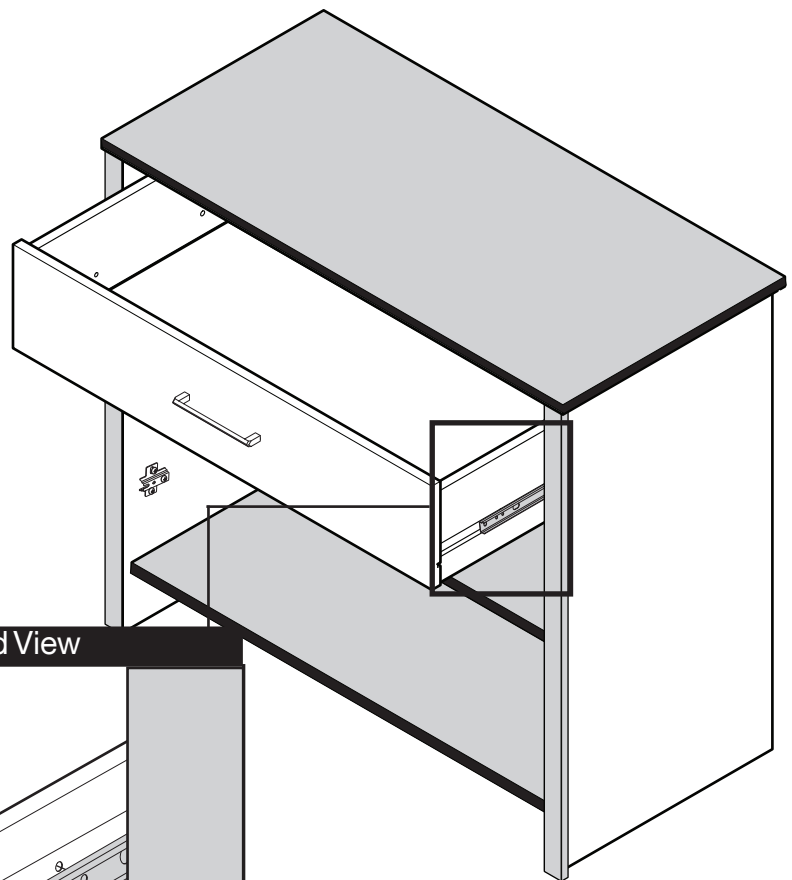

### Detailed View

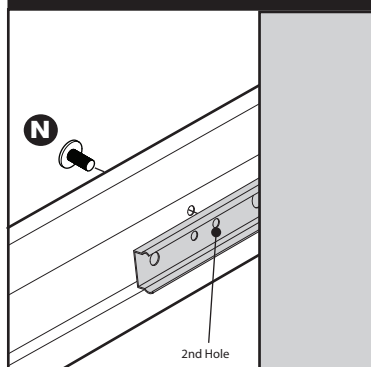



# Assembly Instructions

## Step 21

### Locate drawers helpful hints

**a:** Pull sliding part of drawer runners **K** out so they are fully extended.

**b:** Locate drawer onto runners.

**c:** Locate screwdriver into second threaded hole in drawer runner **K**.

**d:** Keeping screwdriver in place push the drawer in until the screwdriver pushes against the panel. Remove the screwdriver.

**e/f:** Pull drawer out slowly and line the front hole in the drawer side with the 2nd threaded hole in runner **K**. Holding runner and drawer side together insert bolts **N** through the drawer side and into threaded hole in runner **K**.

Now repeat these steps for the other side of the drawer.

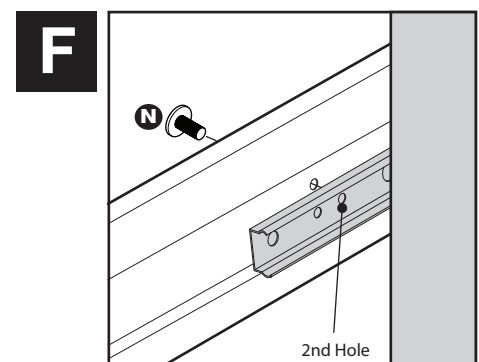
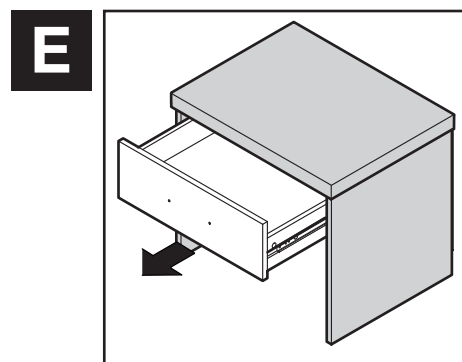
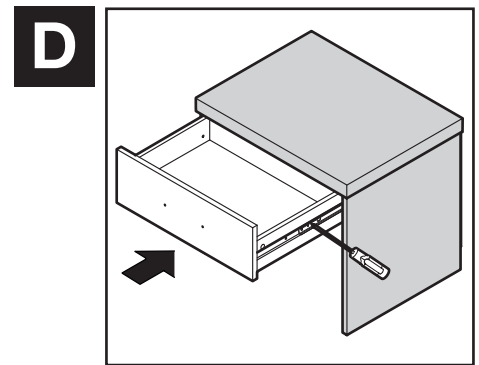
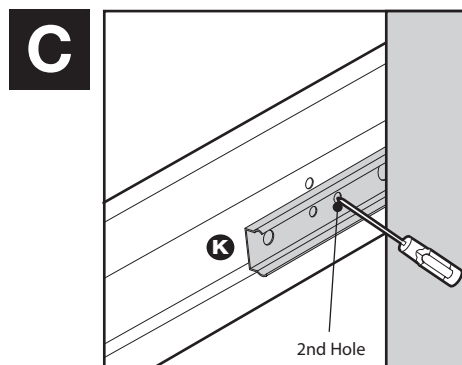
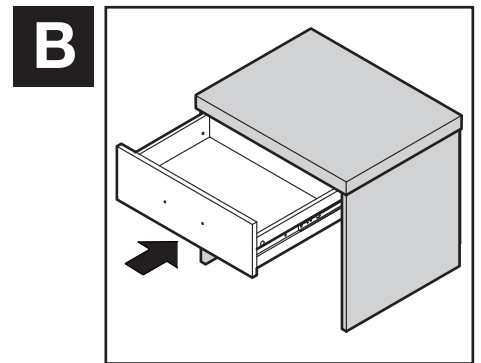
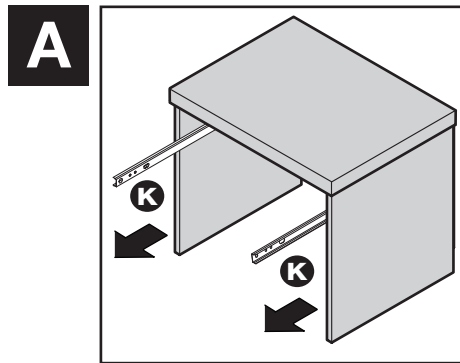

# Assembly Instructions

## Step 22

### Hanging doors

**a:** With help, slot door hinges onto hinge plates. Ensure screw on hinge slides into the slot on hingeplate.

See Diagrams 1, 2 and 3.

**b:** Tighten screw shown to lock hinges in position.

See **'Hinge adjustment'** page if the doors need adjusting.

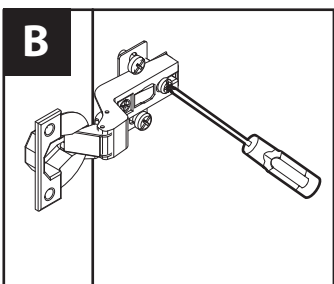
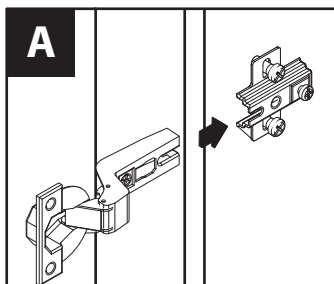
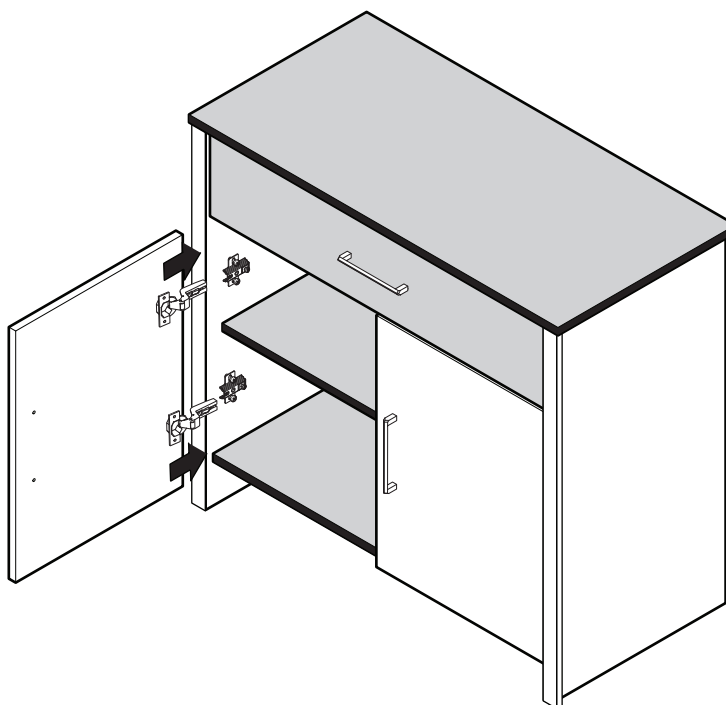
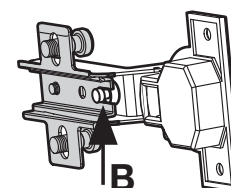

Diagram 1

Underside view



Ensure the underside of screw B slides into slot on hingeplate.

Diagram 2

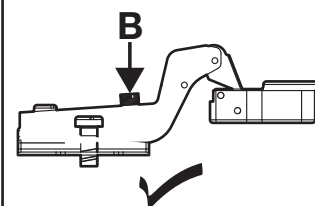

Hinge correctly attached to hingeplate.

Diagram 3

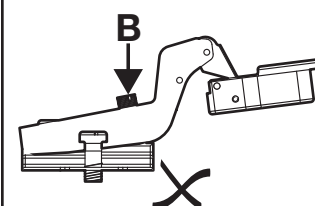

Hinge incorrectly attached to hingeplate.

# Assembly Instructions

## Step 23

### Hinge adjustment

**a:** To move doors up or down: loosen screws shown and move doors to suit.

Re-tighten screws.

**A**

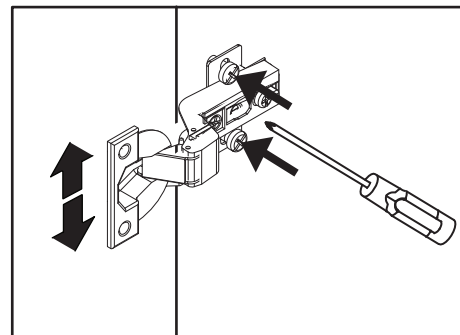
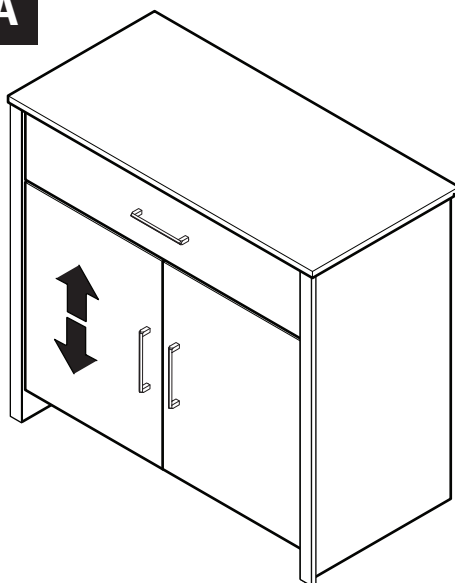

**b:** To move doors in or out: loosen screw shown and move doors to suit.

Re-tighten screws.

**B**

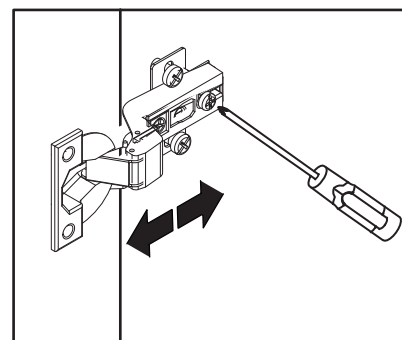
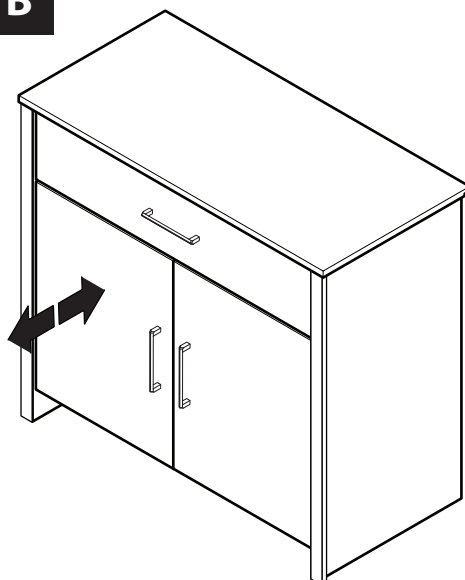

**c:** To move doors left or right: loosen or tighten screw as shown.

Be careful not to fully unscrew.

**C**

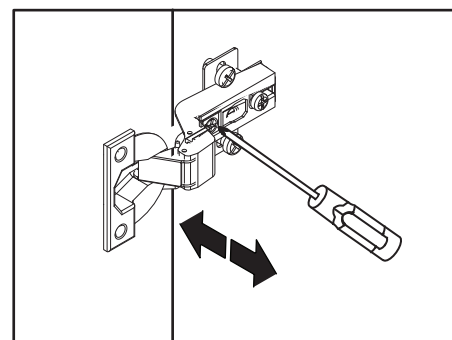
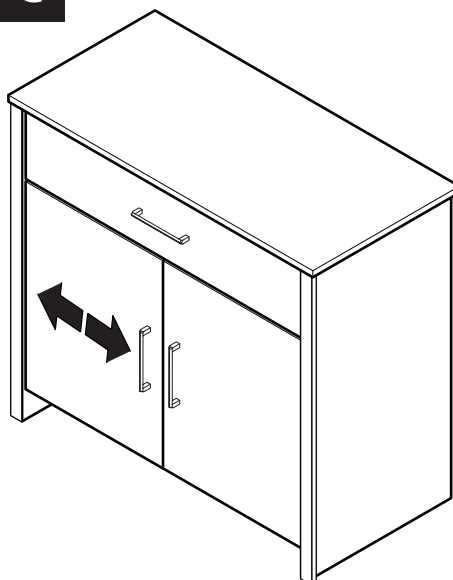

Congratulations! Your unit is complete.

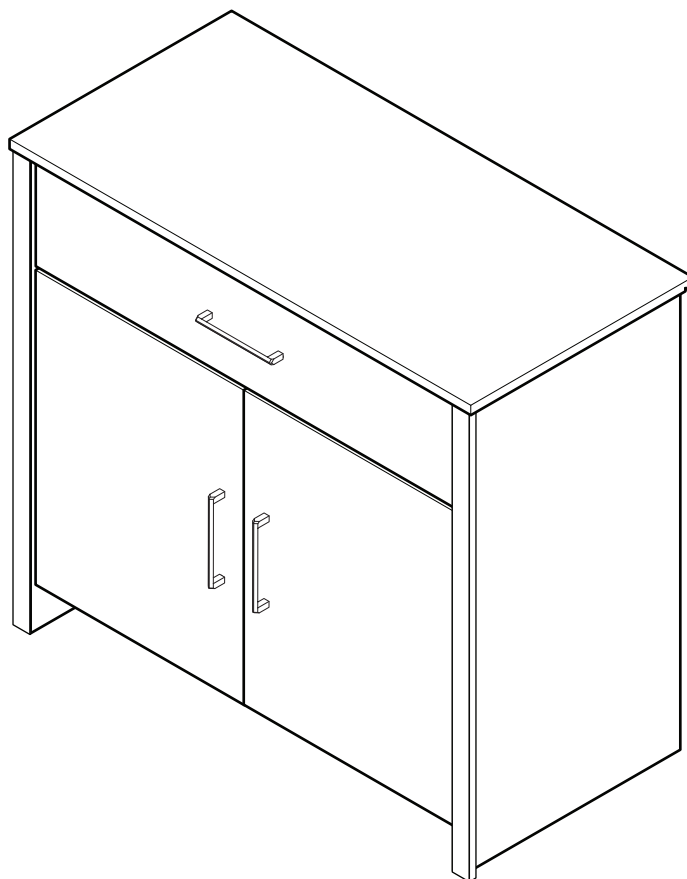

## Important Information

If you need help or have damaged or missing parts, call the **Customer Helpline:**

**01709 534123**

**8am - 4.30pm (Monday to Thursday)**

**8am - 2.30pm (Fridays)**

*(by contacting the customer service line your statutory rights are not affected)*

Please have the following information to hand:

- >> Unit Description
- >> Product Code
- >> Product Colour
- >> Place of Purchase
- >> Catalogue Ref. No.
- >> Item Code
- >> Assembly Instructions

We do have an answer machine should you contact us out of office hours, so in addition to the above information could you leave your name, address, daytime telephone number and the nature of your call on the answerphone. All calls will be actioned asap.

You can also e-mail your requests to us at:

**[customer.helpdesk@addspacefl.co.uk](mailto:customer.helpdesk@addspacefl.co.uk)**

Alternatively, you can write to us at: **Customer Service Department, Addspace Furniture Limited, Braithwell Way, Hellaby Industrial Estate, Hellaby, Rotherham, South Yorkshire, S66 8QY.**