

Wickham Extendable Table

Assembly Instructions - Please keep for future reference

603/7462

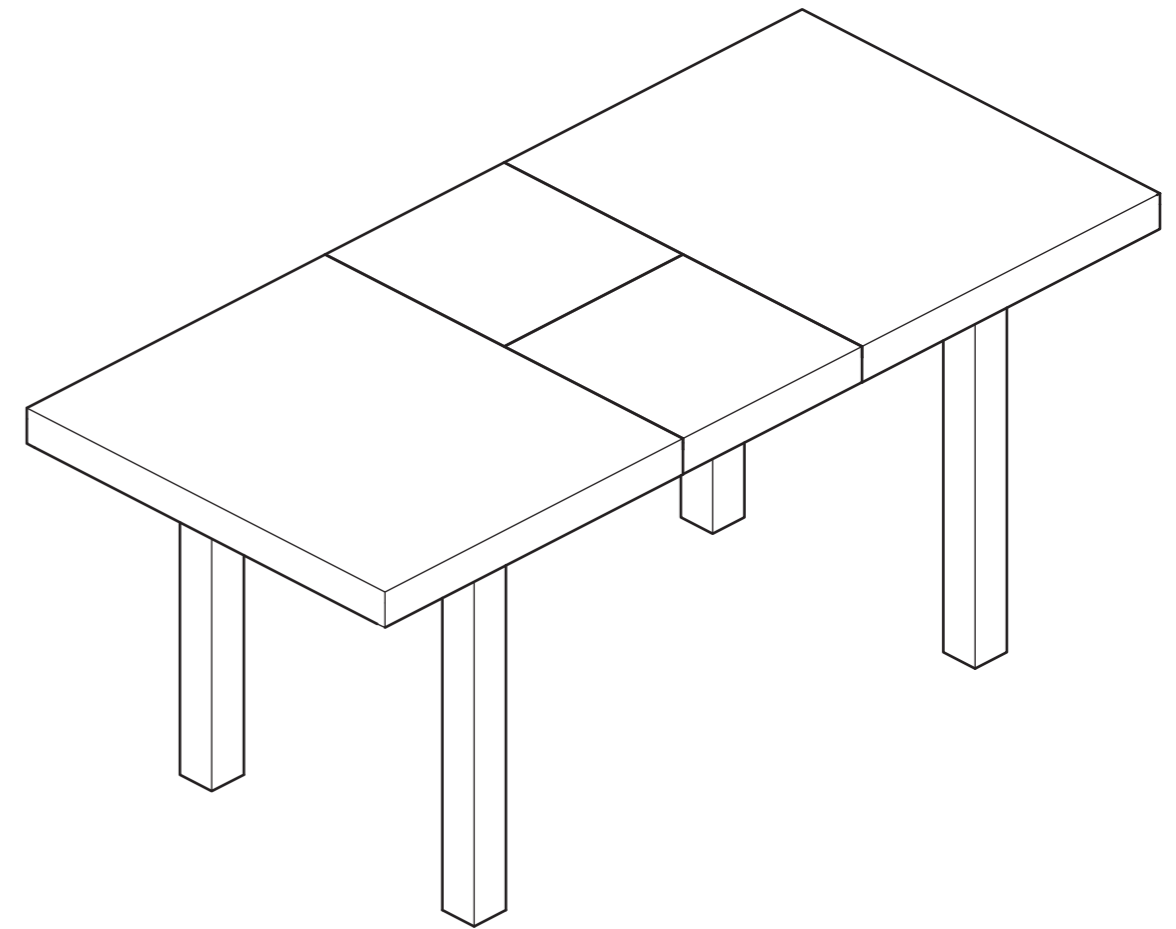

Dimensions

Width - 150 (195)cm
Depth - 90cm
Height - 75cm

Important – Please read these instructions fully before starting assembly

If you need help or have damaged or missing parts, call the **Customer Helpline: 08456 400800**

! Safety and Care Advice

Important – Please read these instructions fully before starting assembly

- Check you have all the components and tools listed on page 2 and 3.
- Remove all fittings from the plastic bags and separate them into their groups.
- Keep children and animals away from the work area, small parts could choke if swallowed.
- Make sure you have enough space to layout the parts before starting.
- Do not stand or put weight on the product during assembly, this could cause damage.
- Assemble the item as close to its final position (in the same room) as possible.
- Assemble on a soft level surface to avoid damaging the unit or your floor.
- Parts of the assembly will be easier with 2 people.



• We do not recommend the use of power drill/drivers **for inserting screws**, as this could damage the unit. Only use hand screwdrivers.

• Dispose of all packaging carefully and responsibly.

Care and maintenance

- Only clean using a damp cloth and mild detergent, do not use bleach or abrasive cleaners.
- From time to time check that there are no loose screws on this unit.
- This product should not be discarded with household waste. Take to your local authority waste disposal centre.

Assembly Instructions

Close table

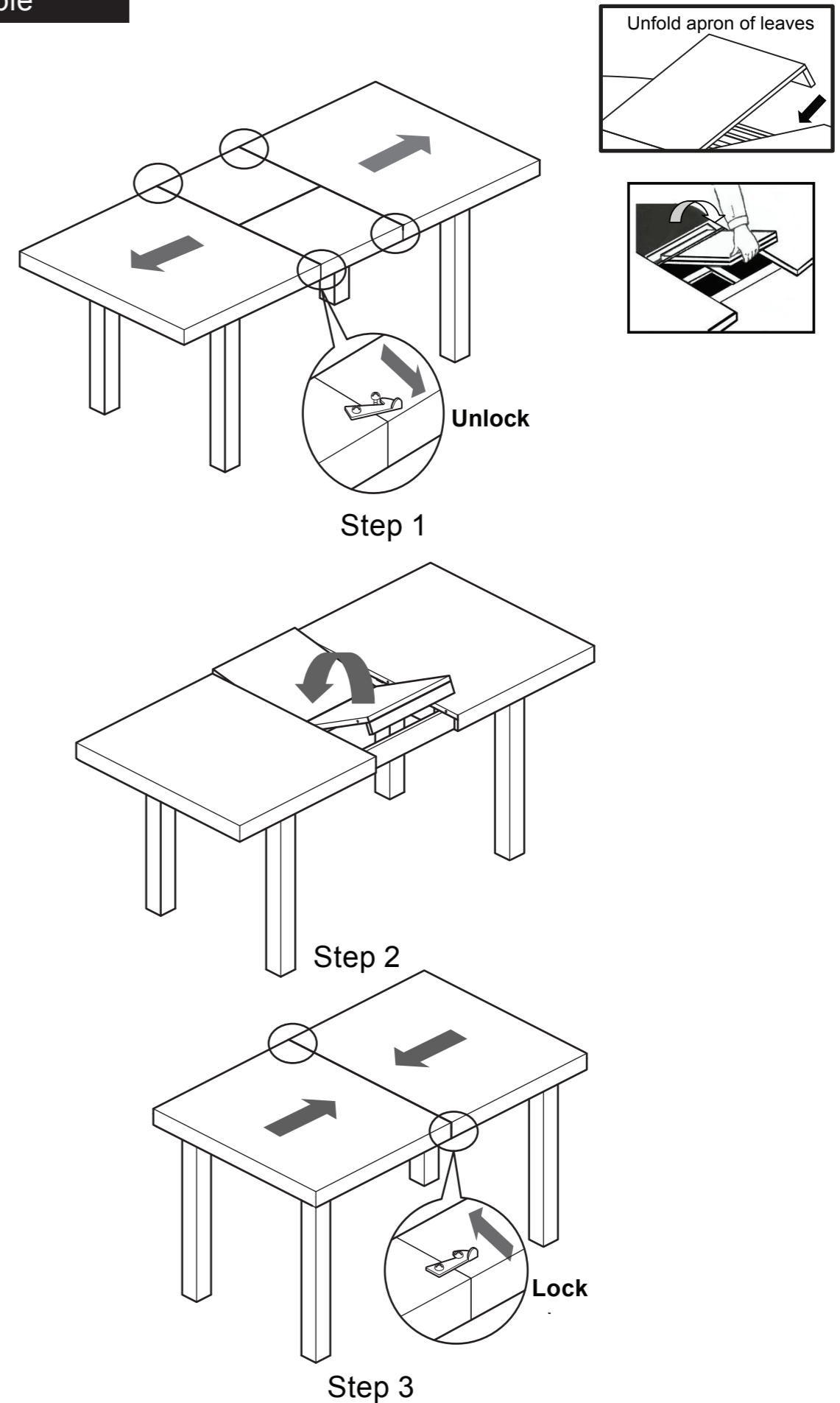

Assembly Instructions

Open table

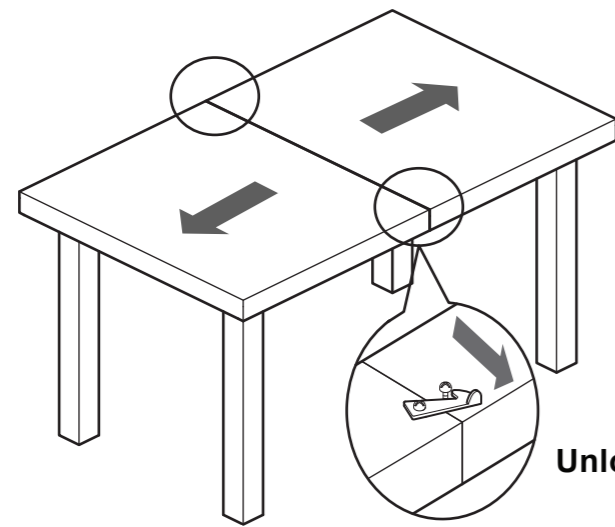

Step 1

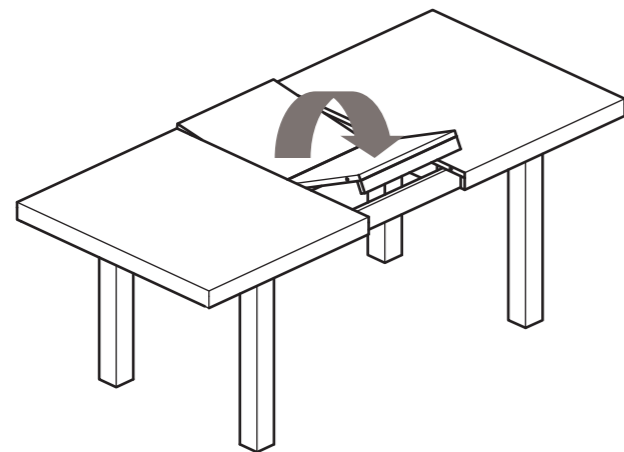
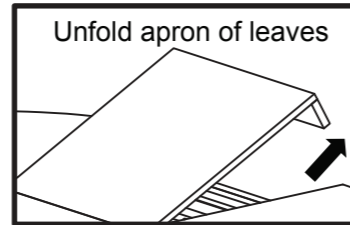

Step 2

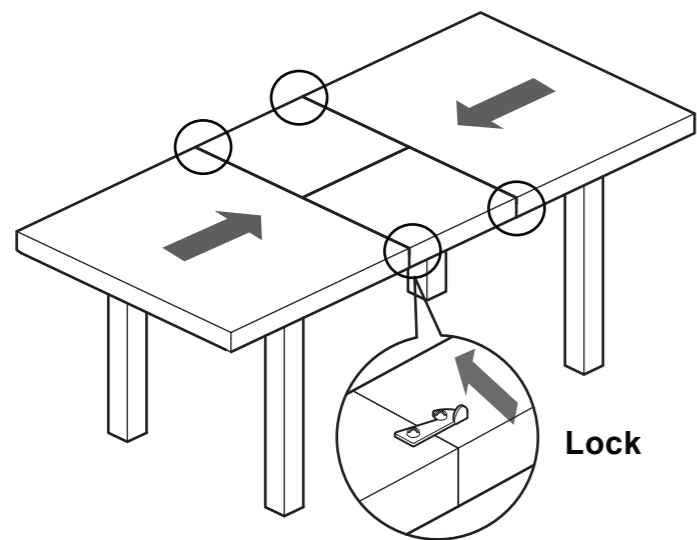

Step 3

Components - Parts

If you have damaged or missing components, call the **Customer Helpline: 08456 40800**

Please check you have all the parts listed below

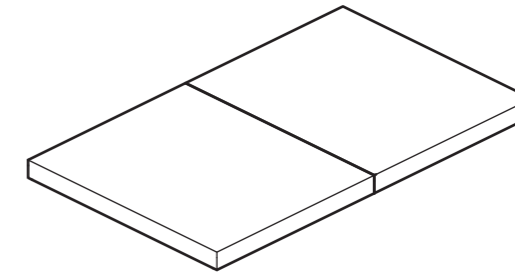

1 Table top x 1

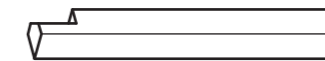





2 Leg x 4

Components - Fittings

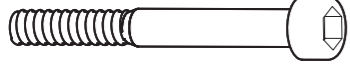
Please check you have all the fittings listed below

Note :The quantities below are the correct amount to complete the assembly. In some cases more fittings may be supplied than are required.

A  Bolt x 8	B  Spring washer x 8	C  Washer x 8
D  Allen key x 1		

Assembly Instructions

Step 1

Place table top upside down being careful to not scratch the table top surface (Leaving the product within its cardboard packaging will assist you in being able to do this)

a:

Now attach the legs **2** (x4) to each of the corners, by first step insert spring washers **B** and washers **C** into all the bolts **A** . Then screw the bolts **A** through the corner blocks and into the holes in the legs **2** . Tighten bolts by using the allen key **D** .

Tighten all 8 bolts securely.

b:

b: 2 people are required for this next stage.

Please now turn the table 180 degrees and place on all four of its legs in your desired location.

Assembly is complete.

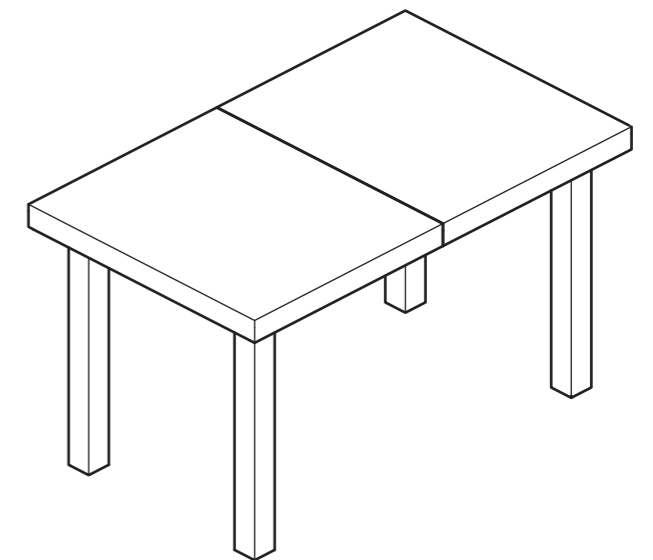
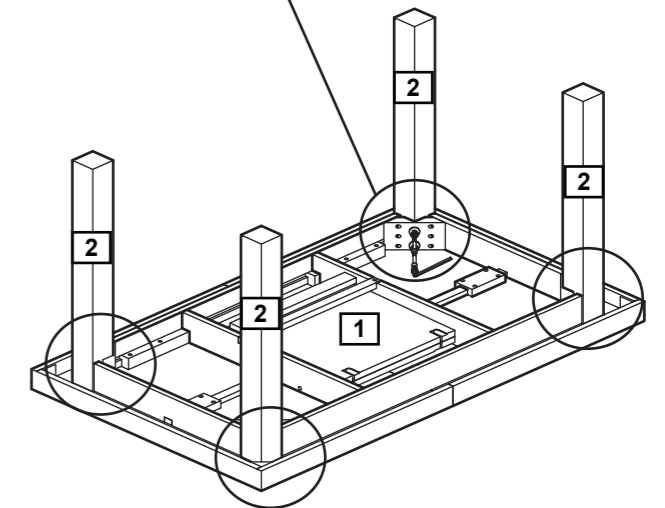
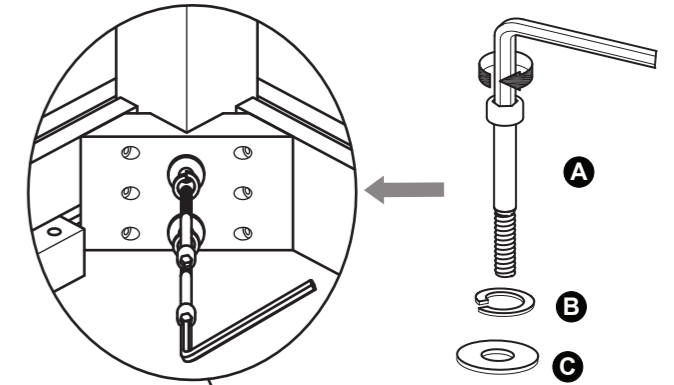

If you need help or have damaged or missing parts, call the **Customer Helpline: 0845 6400800**