

Mid Back Chair

Assembly Instructions - Please keep for future reference

316/4709

321/1456

323/8501

339/9048

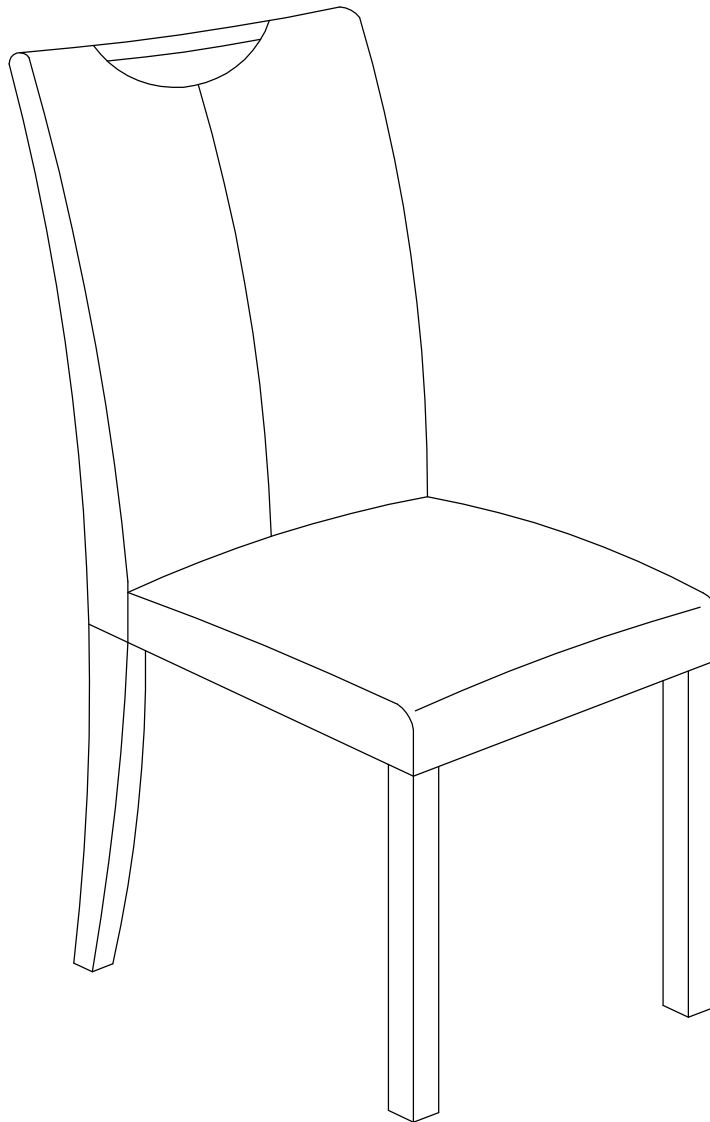

Dimensions

Width - 42.5 cm

Depth - 46 cm

Height - 97 cm

Important - Please read these instructions fully before starting assembly

If you need help or have damaged or missing parts, call the **Customer Helpline : 0345 640 0800**



Safety and Care Advice

Important - Please read these instructions fully before starting assembly

- Keep these instructions for future use.
- Check you have all the components and tools listed on page 2 and 3.
- Do not stand or put excessive weight on the product, this could cause damage.
- Parts of the assembly will be easier with 2 people.
- Do not use this item if any components are missing or damaged.
- During assembly children should be kept away from the product due to possible risk of injury.
- Remove all fittings from the plastic bags and separate them into their groups.
- Dispose of all packaging carefully and responsibly.
- To ensure an easier assembly, we strongly advise that all fittings are only finger tightened during initial assembly. Only upon completion of the assembly should all fixing points be fully tightened.
- We do **NOT** recommend the use of power tools for this assembly.

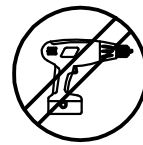

Solid Wood/ Real wood veneers

- This product has been finished using natural materials. As a living material, you may notice some variation in the grain and colour shade between the different components.
- Unlike a synthetic or man-made material which has uniform finish, a feature of natural wood is its variation in grain and colour. We wish to reassure you that this is quite normal and is not the result of any manufacturing fault.
- Where sheets of wood are joined together, a line may be detected. Again, this is normal and is not an imperfection.
- The natural finish should be cared for by the periodic application of a good quality 'wax' based domestic furniture polish (Not silicone!!). Occasional / small spills should be removed immediately using a damp cloth.
- Do not allow hot articles to come into contact with the surface, as damage will occur .

Cleaning Guidance

- Minor Stains and spillages should be removed immediately from cushion fabric, by wiping over lightly with a damp cloth and mild soapy water.
- Light marking can also be removed using this method.
- To remove more stubborn stain or marking, a good quality proprietary domestic fabric cleaner can be used, although it should first be tested on an inconspicuous area of the fabric.

Care and maintenance

- Clean using a damp cloth or a proprietary domestic furniture polish. Do not use abrasive cleaners.
- This product should not be discarded with household waste. Take to your local authority waste disposal only
- From time to time check that there are no loose screws on this unit.

Components - Parts

If you have damaged or missing components,
call the Customer Helpline : 0345 640 080

Please check you have all the parts listed below

- 1 Backrest x2
(97 x 35.5cm)

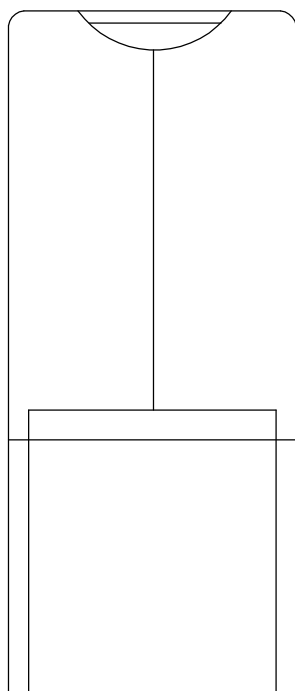

- 3 Front Legs x4
(42.5 x 3.5 x 3.5cm)

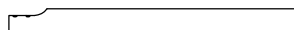

- 2 Seat Pad x2
(41 x 42cm)

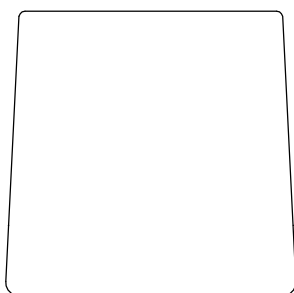







Components - Fittings

If you have damaged or missing components, call the Customer Helpline : 0345 640 080

Please check you have all the fittings listed below

Note : The quantities below are the correct amount to complete the assembly. In some cases more fittings may be supplied than are required.

<p>A</p>  <p>40mm Allen Screw x 4</p>	<p>B</p>  <p>50mm Allen Screw x 8</p>	<p>C</p>  <p>80mm Allen Screw x 8</p>
<p>D</p>  <p>Spring Washer x 20</p>	<p>E</p>  <p>Falt Washer x 20</p>	<p>F</p>  <p>Allen Key x 1</p>

Tools required



Ruler/tape
measure

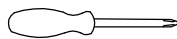

Philips screwdriver

Ruler - Use this ruler to help correctly identify the screws

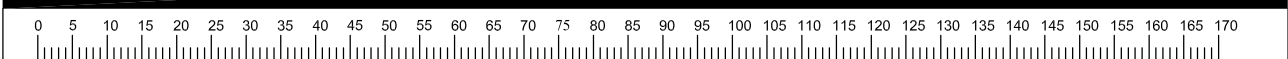

Assembly Instructions

Step 1

Assembling Back Rest

a: Place backrest **1** flat onto the floor with the fixing holes facing up.

Carefully align seat pad **2** onto back rest **1** and secure using fixings **A**, **D** and **E**.

Note : Do not fully tighten at the stage.

a :

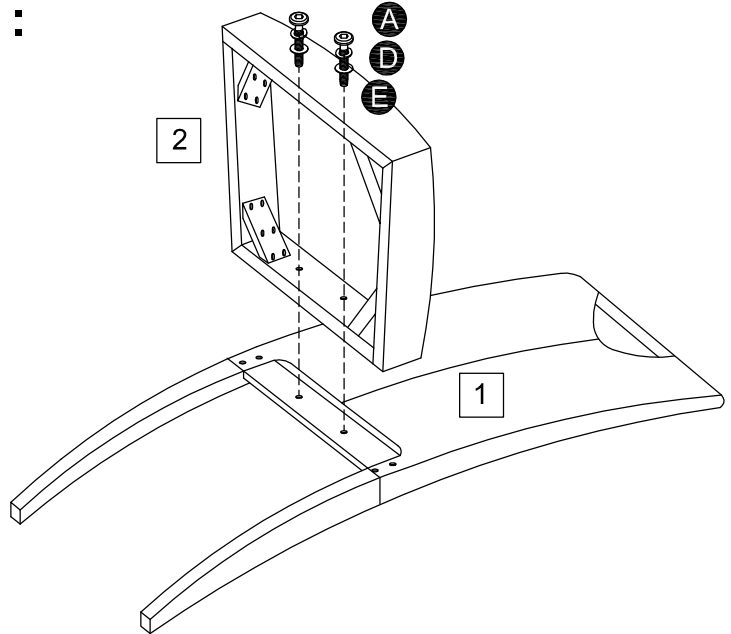

b: Further secure seat pad **2** using fittings **C**, **D** and **E** as shown.

Note : Do not fully tighten at the stage.

b :

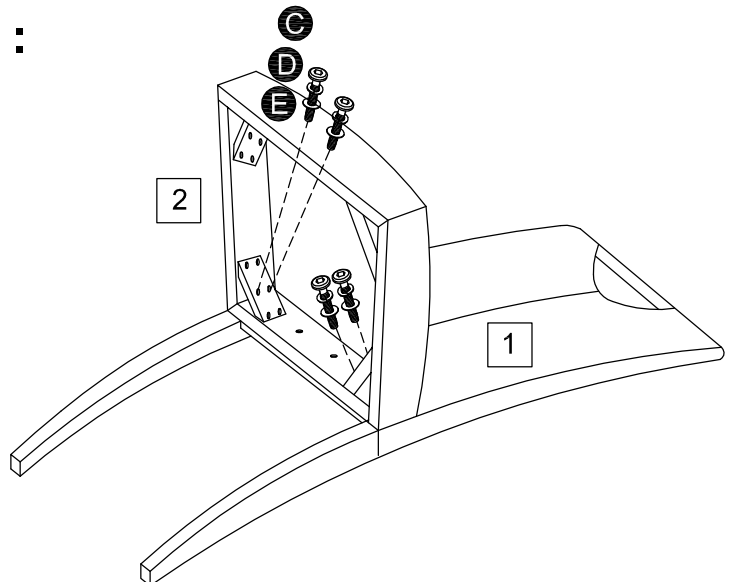

Assembly Instructions

Step 2

Assembling Front Legs

Place the back rest assembly upside down onto a stable flat surface (i.e edge of table).

Assemble front legs **3** to seat pad **2** using fixings **B** , **D** and **E** .

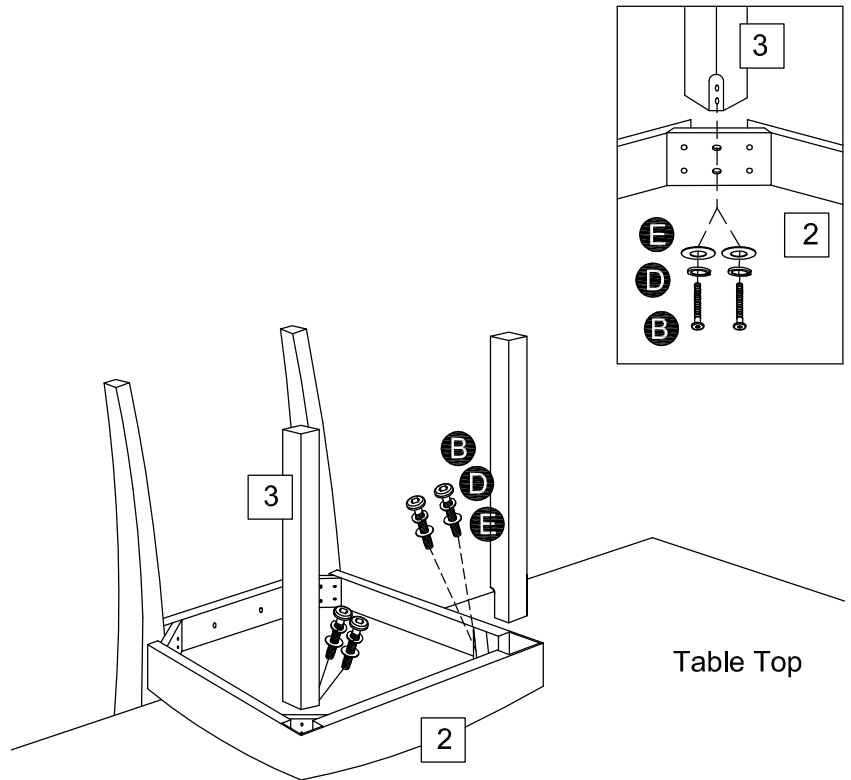

Step 3

Completing Assembly

Turn chair upright and place on a level surface.

Whilst applying a firm downward pressure to the seat , tighten all screws.

Assembly is complete.

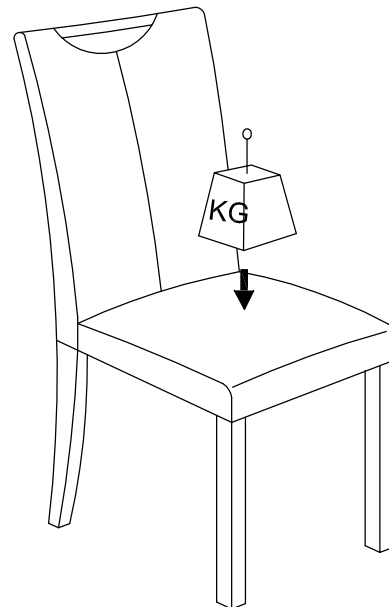

If you need help or have damaged or missing parts, call the **Customer Helpline : 0345 640 0800**
Home Retail Group, 489-499 Avebury Boulevard, Saxon Gate West. Central Milton Keynes
MK9 2NW

Hartley Glass Dining Table

Assembly Instructions - Please keep for future reference

331/1538

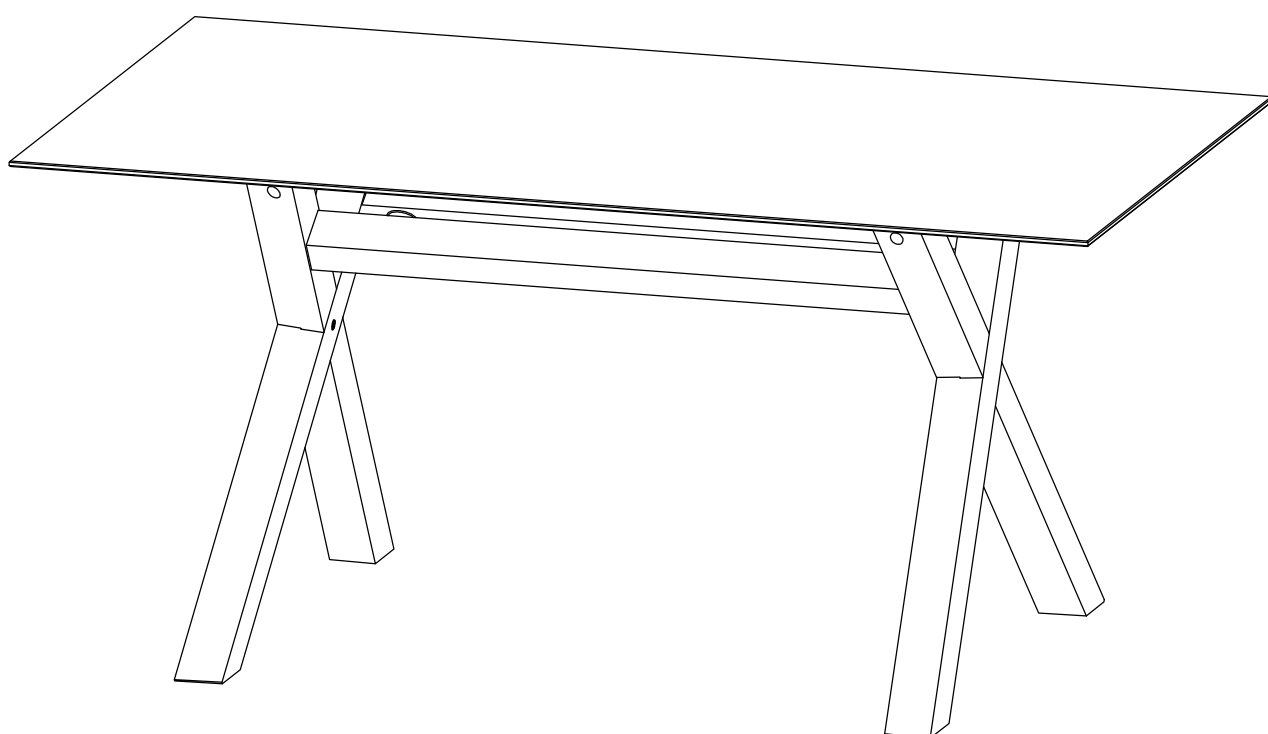

Dimensions

Width - 160cm
Depth - 90cm
Height - 75cm

Important – Please read these instructions fully before starting assembly

If you need help or have damaged or missing parts, call the **Customer Helpline:**
Argos = 0345 6400800



Safety and Care Advice

Important – Please read these instructions fully before starting assembly

- Check you have all the components and tools listed on the following pages.
- Remove all fittings from the plastic bags and separate them into their groups.
- Keep children and animals away from the work area, small parts could choke if swallowed.
- Make sure you have enough space to layout the parts before starting.

- During assembly do not stand or put weight on the product, this could cause damage.
- Assemble the item as close to its final position (in the same room) as possible.
- Assemble on a soft level surface to avoid damaging the unit or your floor.
- Parts of the assembly will be easier with 2 people.



- To reduce the likelihood of damaging your product please ensure that your power drill is set on a low torque setting.

Care and maintenance

- Only clean using a damp cloth and mild detergent, do not use bleach or abrasive cleaners.
- From time to time check that there are no loose screws on this unit.
- This product should not be discarded with household waste. Take to your local authority waste disposal centre.

Handy Hints

- Assemble all parts and bolts loosely during assembly, only once the product is complete should you fully tighten the bolts
- Regularly check and ensure that all bolts and fittings are tightend properly.

Glass Safty

- Keep these instruction for future reference.
- Imported by:
Argos Ltd.
489-499 Avebury Boulevard.
Saxon Gate West.
Central Milton Keynes.
MK9 2NW
- If the glass is chipped or broken, stop using the product and consult the Manufacturer or Supplier.
- Batch No: **545962** (按订单PO号)
- Date of Manufacture: **Nov.2014** (按出货年月)
- Type of glass used: 8mm toughened glass

Warning:

- (a) Do not place very hot or very cold items on the glass surface(s) unless adequately thick table mats are used to prevent such items from coming into contact with the glass.
- (b) Do not sit or stand upon the glass surface(s).
- (c) Do not use the glass as a chopping surface. Do not strike the glass with hard or pointed items.
- (d) When cleaning glass panels use a damp cloth or leather with washing up liquid or soft soap if necessary, do not use washing powders or any other substance containing abrasives since these substances scratch glass.

Components - Panels

If you have damaged or missing components, call the Customer Helpline: Argos = 0345 6400800

Please check you have all the panels listed below

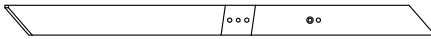

1 Table leg x 2
(104.6 x 7cm)

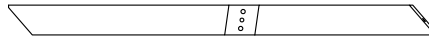

2 Table leg x 2
(104.6 x 7cm)

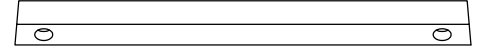

3 Support bar
(87.7 x 6.2cm)



4 Support bar
(87.7 x 6.2cm)

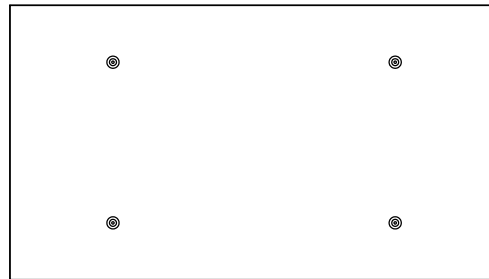







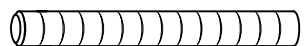

5 Table top
(160 x 90cm)

Components - Fittings

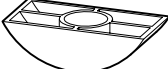
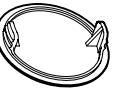
Please check you have all the fittings listed below

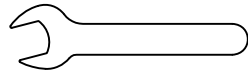
Note: The quantities below are the correct amount to complete the assembly. In some cases more fittings may be supplied than are required.

<p>A </p> <p>40mm Bolt x 4</p>	<p>B </p> <p>50mm Bolt x 2</p>	<p>C </p> <p>80mm Screw x 4</p>
<p>D </p> <p>Plain washer x 8</p>	<p>E </p> <p>Nut x 4</p>	<p>F </p> <p>Connector x 4</p>
<p>G </p> <p>Cap x 4</p>	<p>H </p> <p>Wooden dowel X 8</p>	<p>I </p> <p>Wrench X 1</p>
<p>J </p> <p>Hex key X 1</p>		

Ruler - Use this ruler to help correctly identify the screws

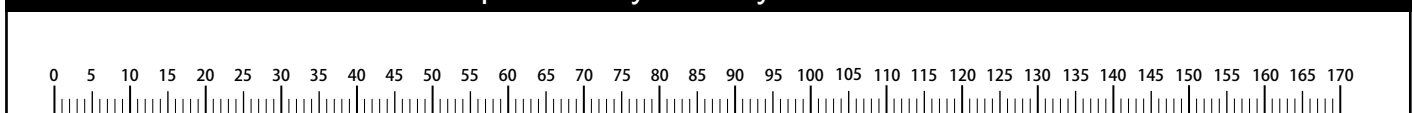

The bolts length is measured from the head to the point (40mm bolt shown).

Assembly Instructions

Step 1

Assemble table legs

a: Fix table leg **1** and **2** by using bolt **B**, wooden dowels **H**.

a:

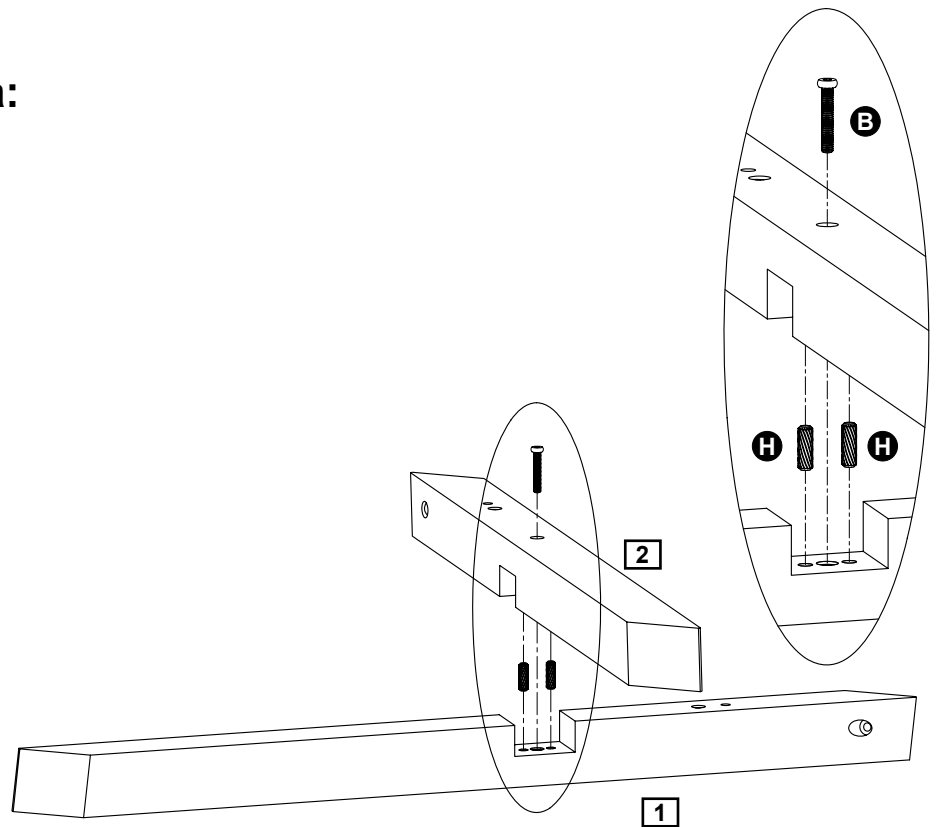

b: Fix screws **C** and insert wooden dowels **H** into table legs.

b:

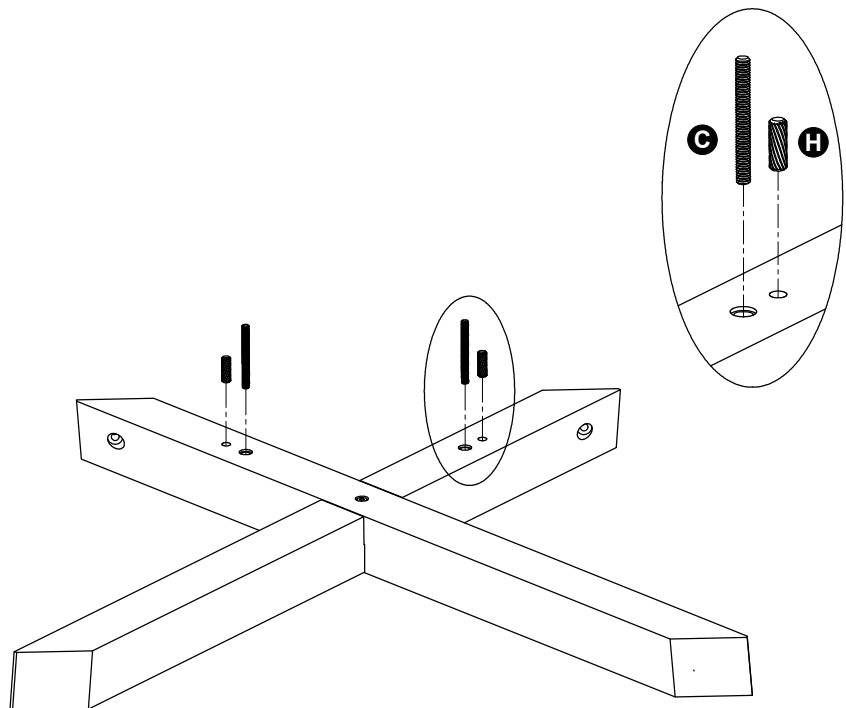

Assembly Instructions

Step 2

Assemble support bars

a: Attach support bars **3** and **4** to table legs, then fix with connectors **F**, plain washers **D** and nuts **E**.

a:

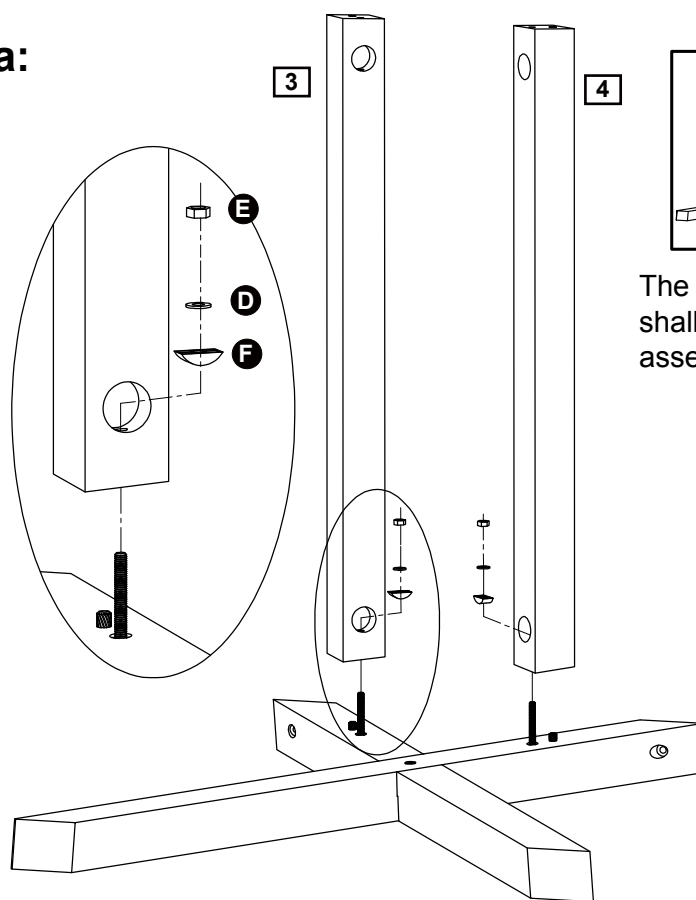

The support bars **3** and **4** shall be in parallel after assembled.

b: Fix another leg frame with connectors **F**, plain washers **D** and nuts **E**.

b:

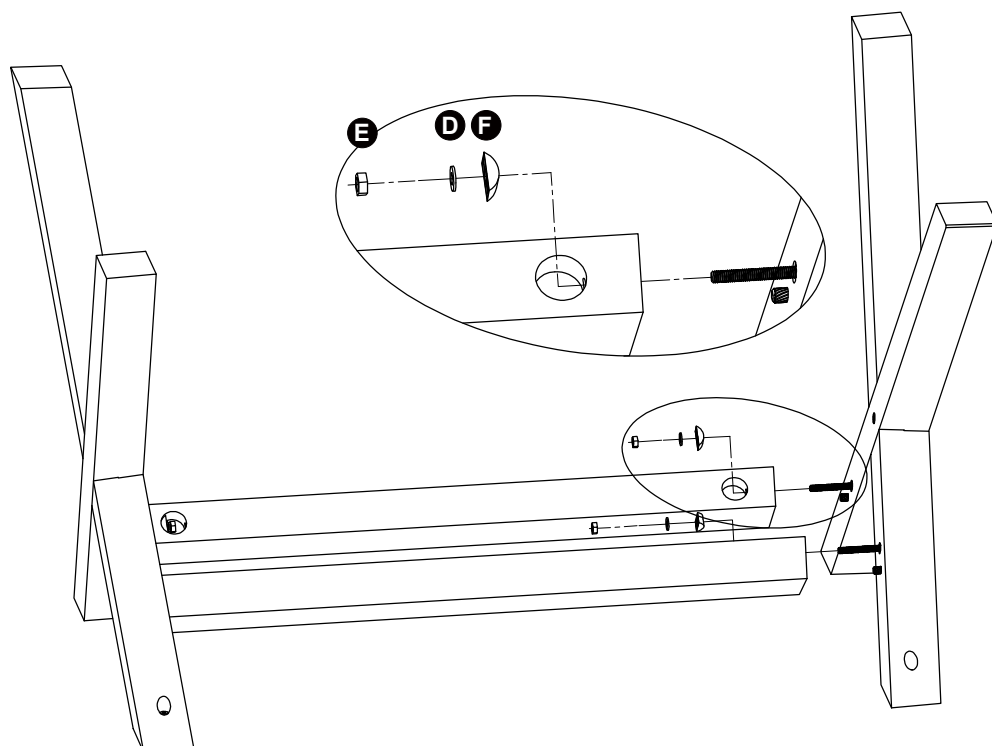

Important note: Do not fully tighten bolts at this stage.

Assembly Instructions

Step 3

Assemble table top

Two people are needed here.

Place table top **5** upside down on a clean protected surface.

Fix the assembled unit frame onto table top using bolts **A**, plain washers **D**.



Important note: After all the parts are positioned, you can now fully tighten all bolts fixed on previous steps.

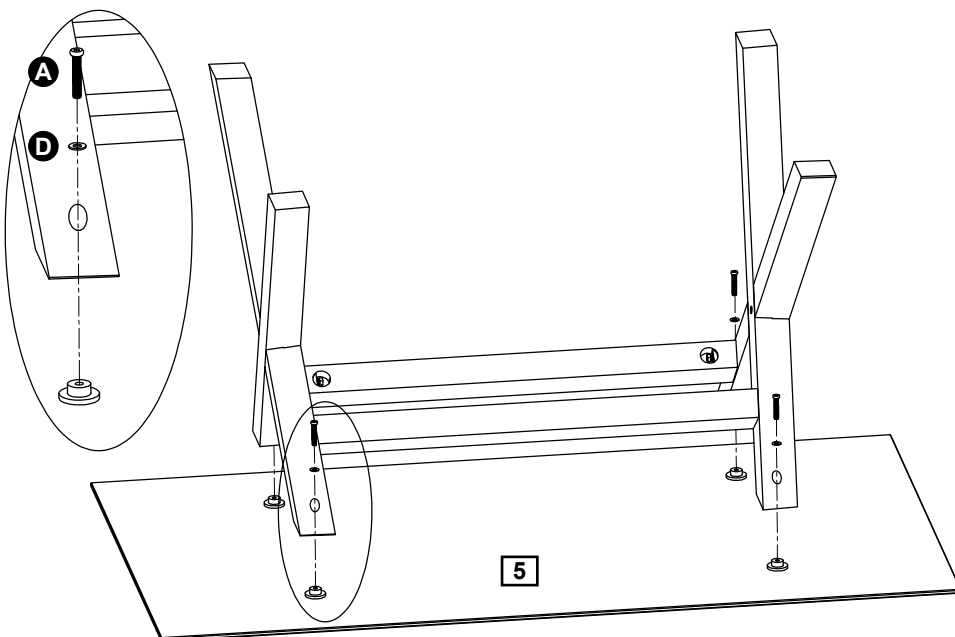

Step 4

Assemble cap

Cover the holes by using caps **G** as shown.

Turn the table upright.

Remove the plastic film on table top.

Assemble is complete

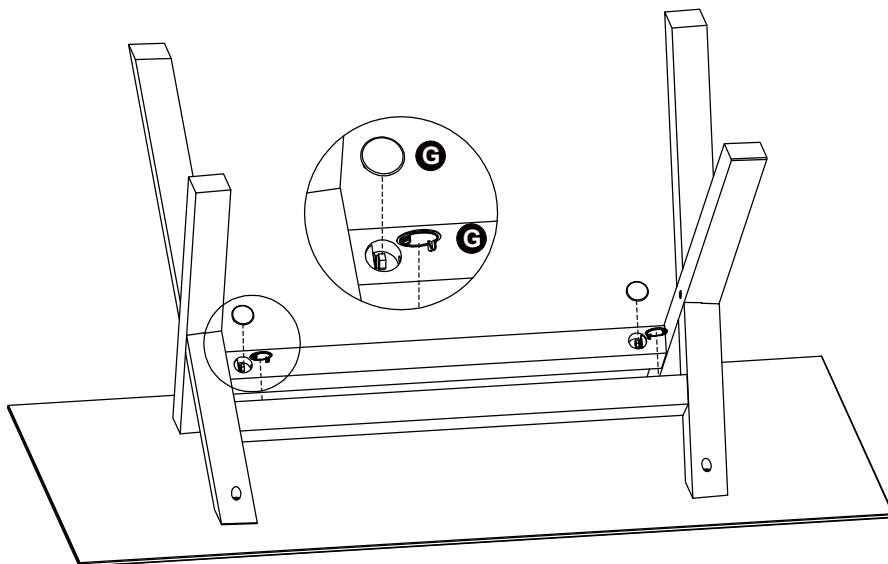

If you need help or have damaged or missing parts, call the **Customer Helpline:**
Argos = 0345 6400800