

Berkeley - TV Unit

Assembly Instructions - Please keep for future reference

414/8645

hygena

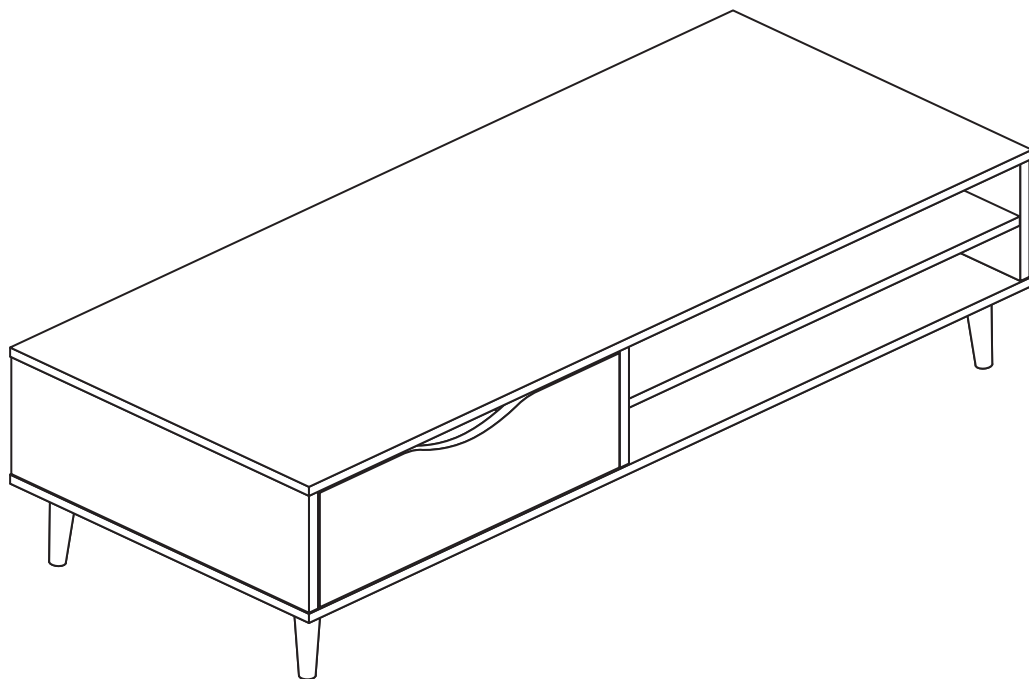

Dimensions

Width - 119.5cm

Depth - 49.5cm

Height - 34.5cm



**MADE IN
BRITAIN**

Important - Please read these instructions fully before starting assembly

If you need help or have damaged or missing parts, call the **Customer Helpline: 08456 400800**



Safety and Care Advice

Important - Please read these instructions fully before starting assembly

- **Warning:** This unit weighs approximately 25kgs. Please lift with care.

- Check you have all the components and tools listed on pages 2 and 3.

- Remove all fittings from the plastic bags and separate them into their groups.

- Keep children and animals away from the work area, small parts could choke if swallowed.

- Parts of the assembly will be easier with 2 people.

- Make sure you have enough space to layout the parts before starting.

- Do not stand or put weight on the product, this could cause damage.

- Assemble the item as close to its final position (in the same room) as possible.

- Assemble on a soft level surface to avoid damaging the unit or your floor (use opened out unit carton).



- We do not recommend the use of power drill/drivers **for inserting screws**, as this could damage the unit. Only use hand screwdrivers.

- **Safety note:** If there is any chance of this unit being pulled over by children etc. it is recommended that the unit is secured to a wall using suitable fixings (not supplied).

- Dispose of all packaging carefully and responsibly.

Care and maintenance

- Only clean using a damp cloth and mild detergent, do not use bleach or abrasive cleaners.

- From time to time check that there are no loose screws on this unit.

- This product should not be discarded with household waste. Take to your local authority waste disposal centre.

Note: If required the next page can be cut out and used as reference throughout the assembly. Keep this page with these instructions for future reference.

Components - Panels

If you have damaged or missing components, call the **Customer Helpline: 03456 400800** quoting the reference numbers below

Please check you have all the panels listed below

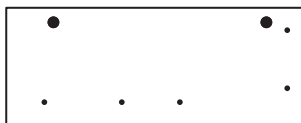

1 Left End (DF2874)
(195 x 490mm)

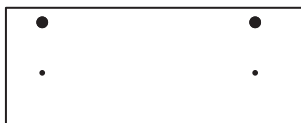

2 Right End (DF3964)
(195 x 490mm)

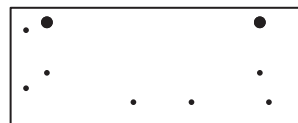

3 Divider (DF3966)
(195 x 490mm)

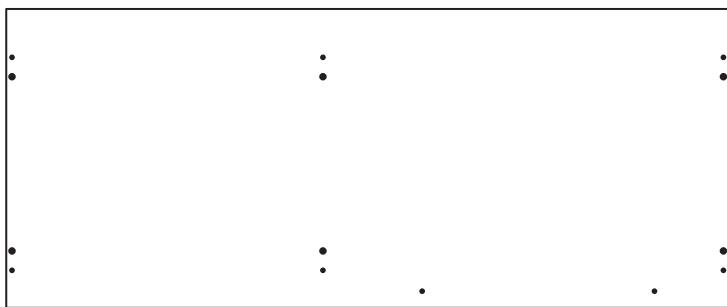

4 Top (DF3962)
(1195 x 494mm)



5 Shelf (DF3965)
(647 x 455mm)

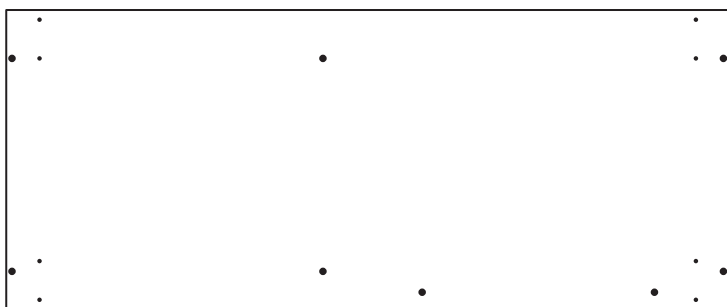

6 Base (DF3963)
(1195 x 494mm)



7 Left Back (DF3060)
(499 x 195mm)



8 Right Back (DF3967)
(195 x 597mm)

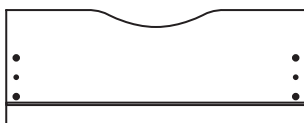

9 Drawer Front (DF2877)
(495 x 189mm)



10 Left Drawer Side (W370-124LH)
(370 x 124mm)



11 Right Drawer Side (W370-124RH)
(370 x 124mm)



12 Drawer Back (W449-124)
(449 x 124mm)



13 Drawer Base (T460-367)
(460 x 367mm)











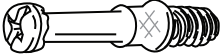





Components - Fittings

If you have damaged or missing components, call the **Customer Helpline: 03456 400800** quoting the reference numbers below

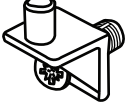
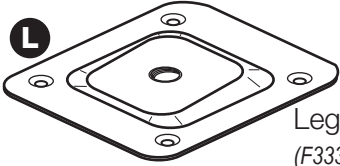
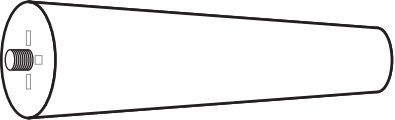
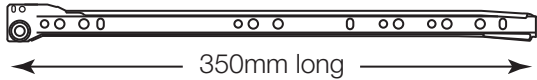
Please check you have all the fittings listed below

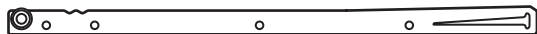
Note: The quantities below are the correct amount to complete the assembly. In some cases more fittings may be supplied than are required.

<p>A </p> <p>Metal dowel (F901) x 14</p>	<p>B </p> <p>Small locking nut (F3) x 2</p>	<p>C </p> <p>Large locking nut (F900) x 12</p>
<p>D </p> <p>Wooden dowel (F22) x 6</p>	<p>E </p> <p>Knock-in Peg (F171GY) x 4</p>	<p>F </p> <p>50mm Screw (F49) x 8</p>
<p>G </p> <p>13mm Screw (F79) x 16</p>	<p>H </p> <p>9mm Screw (F73) x 6</p>	<p>I </p> <p>13mm Screw (F63) x 6</p>
<p>J </p> <p>Wedgefix (F639) x 2</p>	<p>K </p> <p>Shelf stud (F372) x 4</p>	<p>L </p> <p>Leg Bracket (F333) x 4</p>
<p>M </p> <p>Leg (F343) x 4</p>	<p>Oa  L Runner (F159) x 1 ← 350mm long →</p> <p>Ob  R Runner (F160) x 1</p> <p>Oc  L Runner (F161) x 1</p> <p>Od  R Runner (F162) x 1</p>	
<p>N </p> <p>Allen Key (F36) x 1</p>		

Tools required

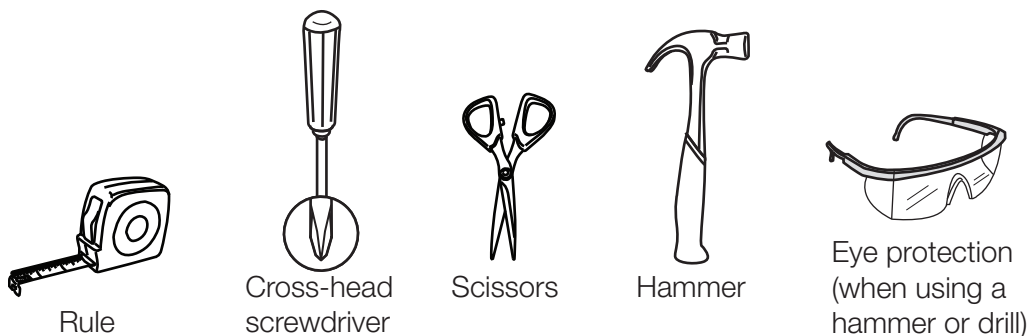

Ruler - Use this ruler to help correctly identify the screws

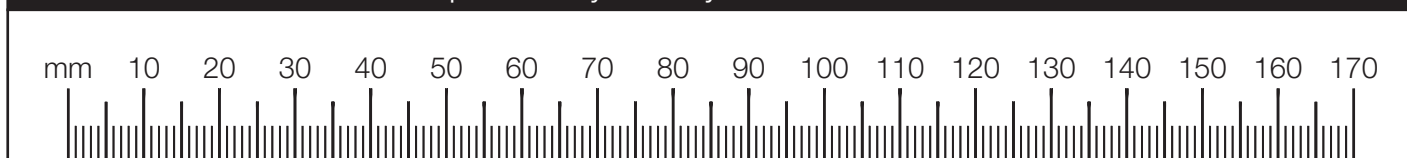

Assembly Instructions

If you have damaged or missing components, call the
Customer Helpline: 03456 400800 quoting the reference
numbers below

Step 1

Prepare the drawer front

Screw 2 metal dowels **A** into the drawer front **9**.

Note: Tighten the metal dowels up fully against the panels.

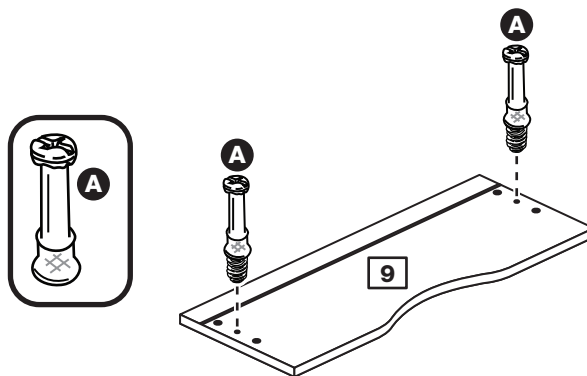

Step 2

Prepare the drawer sides

Insert a small locking nut **B** into the hole shown on the left drawer side **10** and the right drawer side **11**.

Note: The arrow on the locking nut **must** point towards the hole in the edge of the panel.

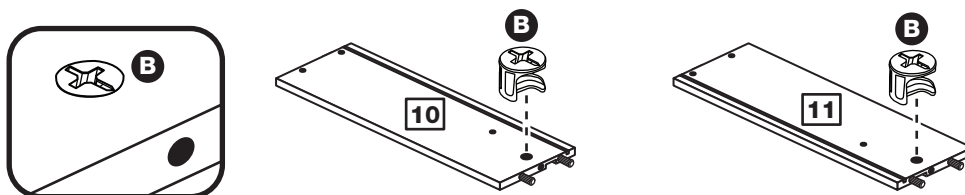

Step 3

Attach the drawer sides to the drawer front

Push the left drawer side **10** and right drawer side **11** onto the back of the drawer front **9**.

Turn the small locking nuts **B** on the left drawer side **10** and right drawer side **11**.

Note: Turn the locking nuts **B** clockwise to secure panels - more than 1/2 a turn.

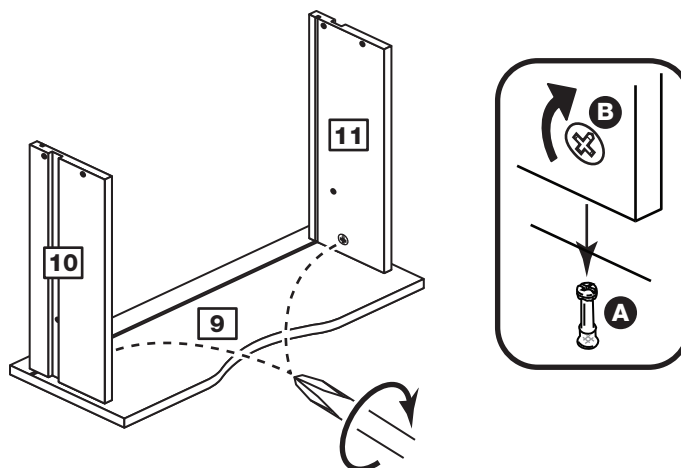

Assembly Instructions

Step 4

Fit the drawer base

Slide the drawer base **13** down the grooves in the drawer sides **10** and **11** and down into the groove in the drawer front **9**.

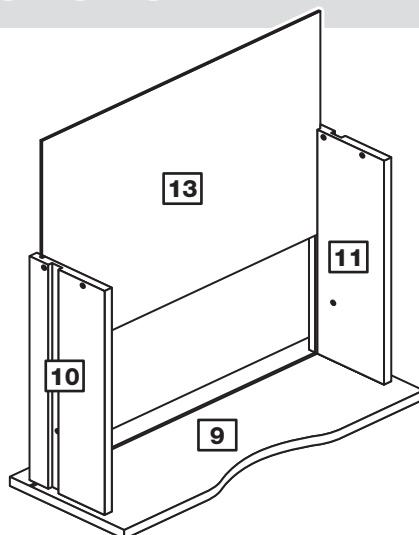

Step 5

Fit the drawer back

Fit the drawer back **12** between the drawer sides **10** and **11**. Make sure that the drawer base **13** fits into the groove in the drawer back **12**.

Hold the drawer back **12** in position and tap the knock-in pegs **E** through the holes in the drawer sides **10** and **11**.

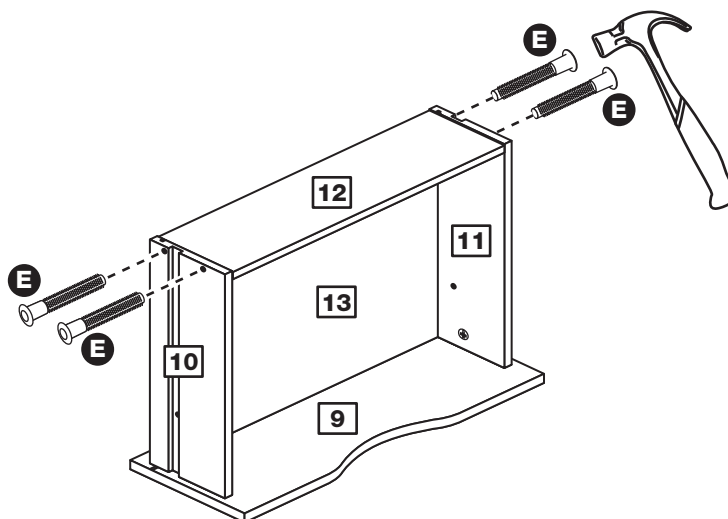

Step 6

Fit the wedgifixes

Turn the drawer assembly over and slide 2 wedgifixes **J** into the front and back grooves, as shown, and tighten up the screws.

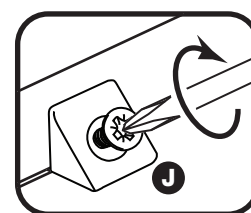
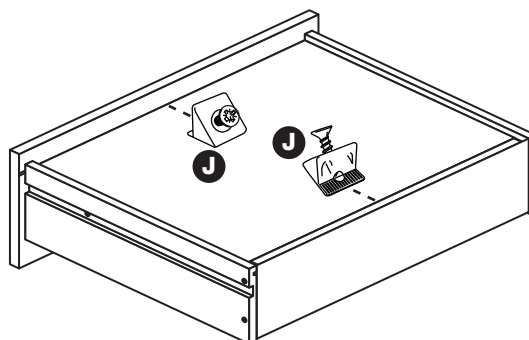

Assembly Instructions

Step 7

Fit runners to the drawers

Fit the runner **Oc** to the bottom edge of the left drawer side **10**, as shown, making sure that it is pushed up against the back of the drawer front **9**. Use a bradawl to mark the fixing positions, then secure with 2 screws **I**.

Fit the runner **Od** to the bottom edge of the right drawer side **11** using the same method.

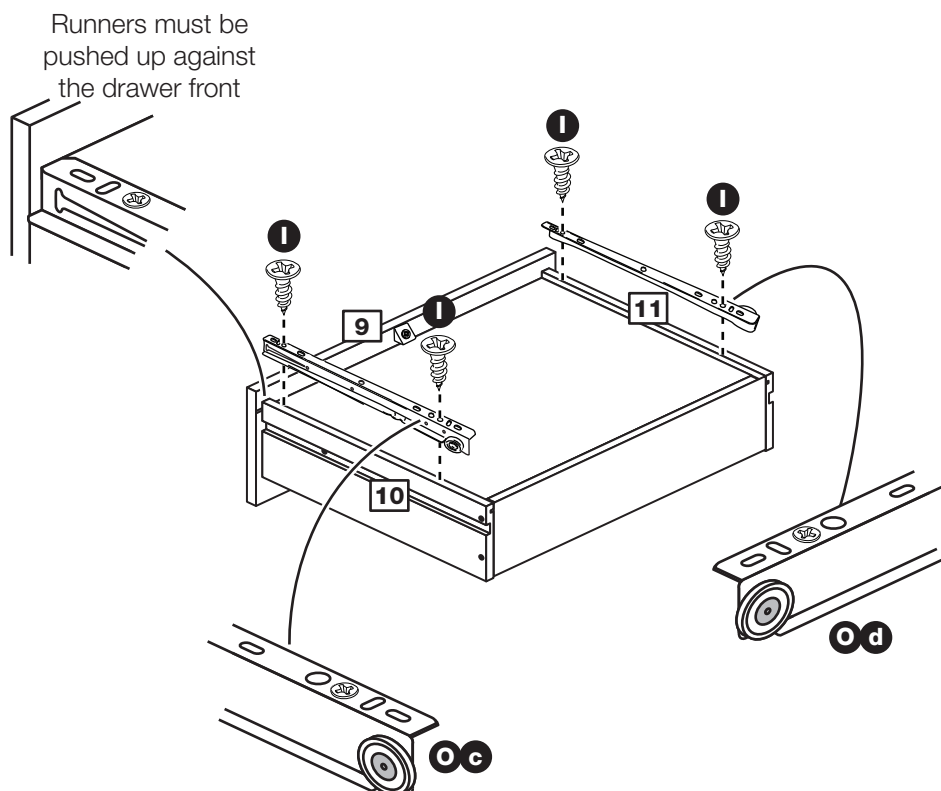

Step 8

Prepare the top

Screw 8 metal dowels **A** into the top **4**.

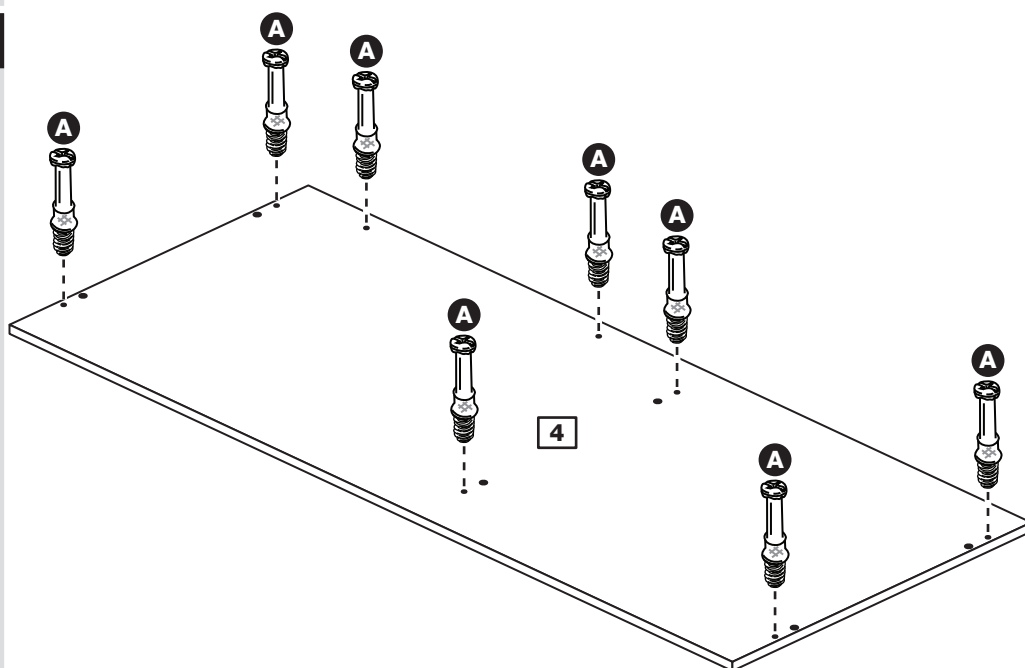

Assembly Instructions

Step 9

Prepare the right end

Insert 2 large locking nuts **C** into the right end **2**.

Note: The arrow on the locking nuts **must** point towards the hole in the edge of the panel.

Tap 2 wooden dowels **D** into the right end **2**.

Note: Wooden dowels **must not** stick out from the edge by more than 10mm or they may damage other panels.

Push 2 shelf studs **K** into the right end **2** and tighten the screws up.

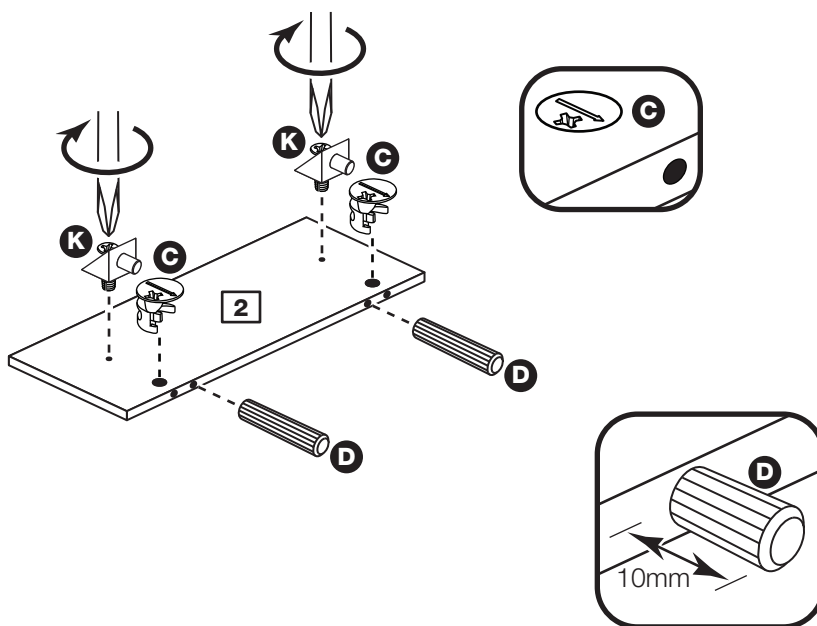

Step 10

Fit the right end to the top

Push the right end **2** onto the top **4**.

Use a screwdriver to tighten the 2 large locking nuts **C** fitted to the right end **2**.

Note: Turn the large locking nuts **C** as far as they will go - more than 1/2 a turn.

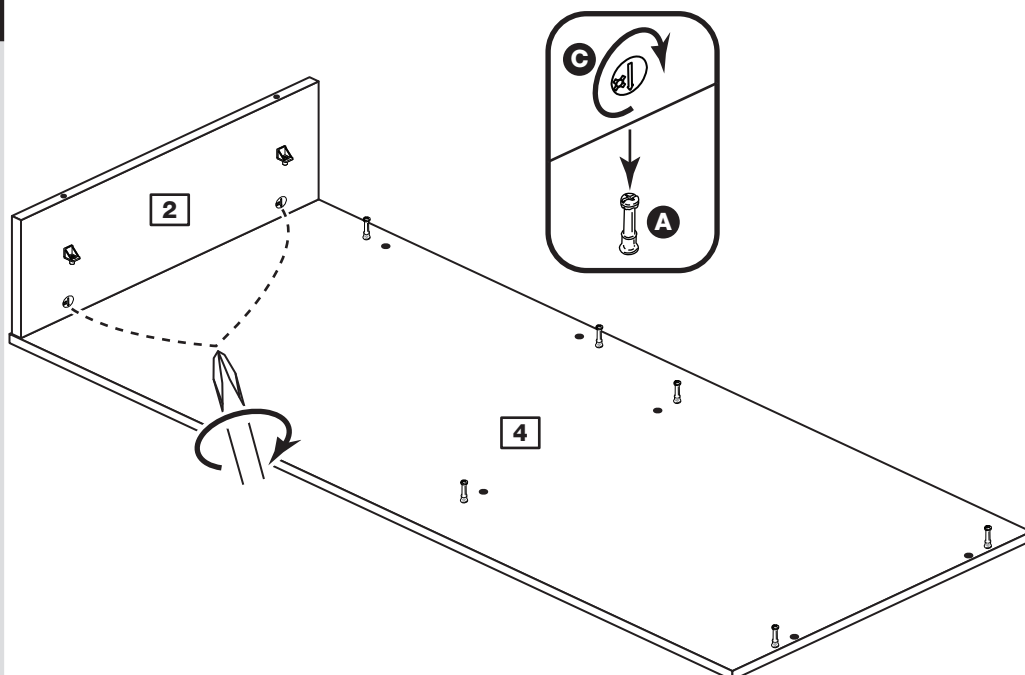

Assembly Instructions

Step 11

Prepare the right back

Insert 2 large locking nuts **C** into the right back **8**.

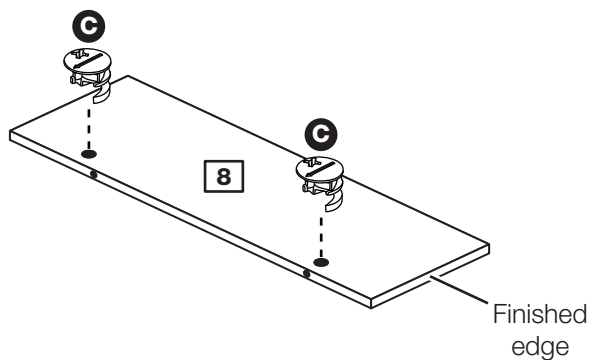

Step 12

Fit the right back to the top

Push the right back **8** onto the top **4**.

Use a screwdriver to tighten the 2 large locking nuts **C** fitted to the right back **8**.

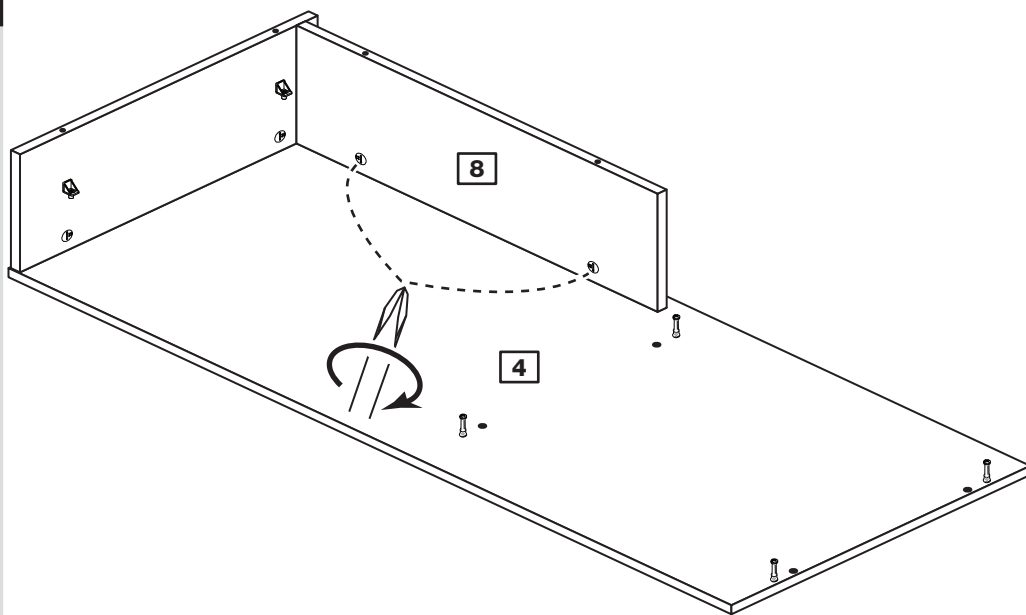

Step 13

Prepare the left back

Insert 4 large locking nuts **C** into the left back **7**.

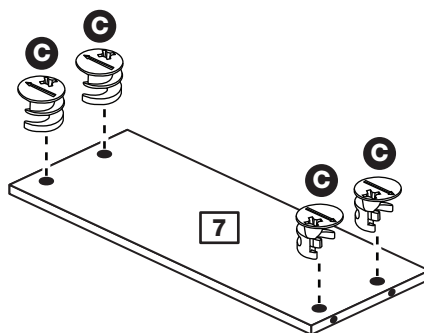

Assembly Instructions

Step 14

Prepare the divider

a: Fit a runner **O b** to the divider **3**.

The 1st screw **H** uses the 1st hole in from the front of the runner.

The 2nd and 3rd screws **H** use the holes that line up with the other panel holes.

b: Fit a screw **I** into the 2nd hole in at the top of the runner **O b**.

c: Screw 2 metal dowels **A** into the divider **3**.

Insert 2 large locking nuts **C** into the divider **3**.

Tap 2 wooden dowels **D** into the divider **3**.

Turn the divider over

d: Push 2 shelf studs **K** into the divider **3** and tighten the screws up.

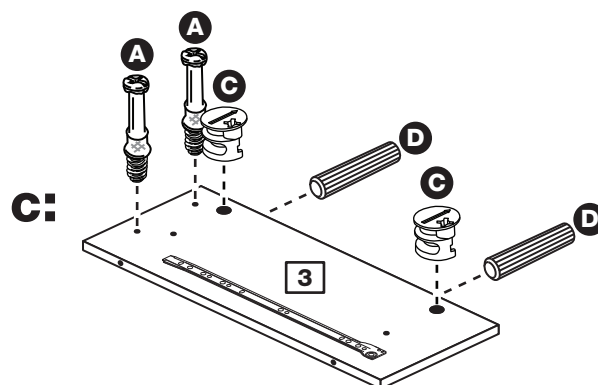
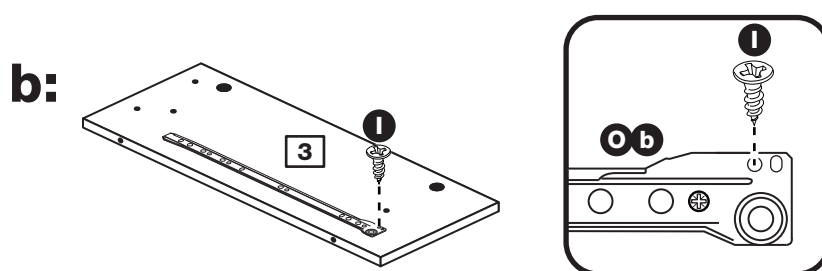
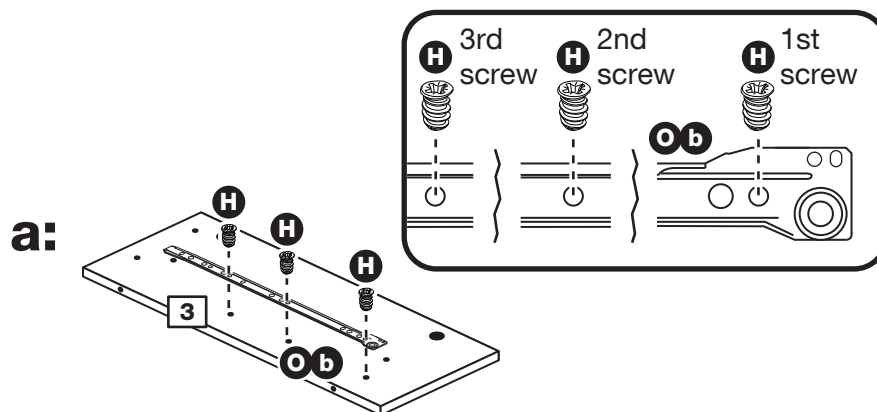

Turn the divider over

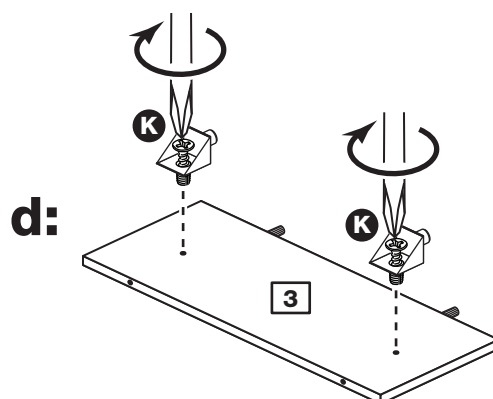

Assembly Instructions

Step 15

Fit the left back to the divider

Push the left back **7** onto the divider **3**.

Use a screwdriver to tighten the 2 large locking nuts **C** fitted to the divider **3**.

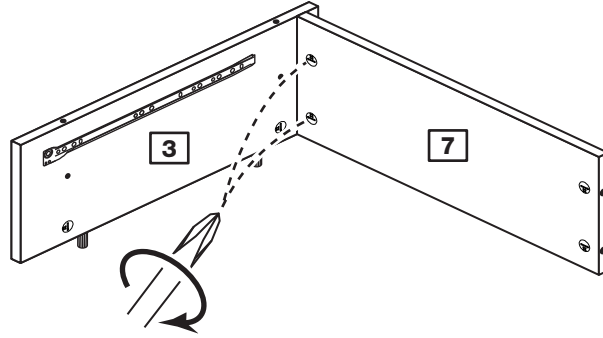

Step 16

Prepare the left end

a: Fit a runner **Oa** to the left end **1**.

The 1st screw **H** uses the 1st hole in from the front of the runner.

The 2nd and 3rd screws **H** use the holes that line up with the other panel holes.

b: Fit a screw **I** into the 2nd hole in at the top of the runner **Oa**.

Screw 2 metal dowels **A** into the left end **1**.

c: Insert 2 large locking nuts **C** into the left end **1**.

Tap 2 wooden dowels **D** into the left end **1**.

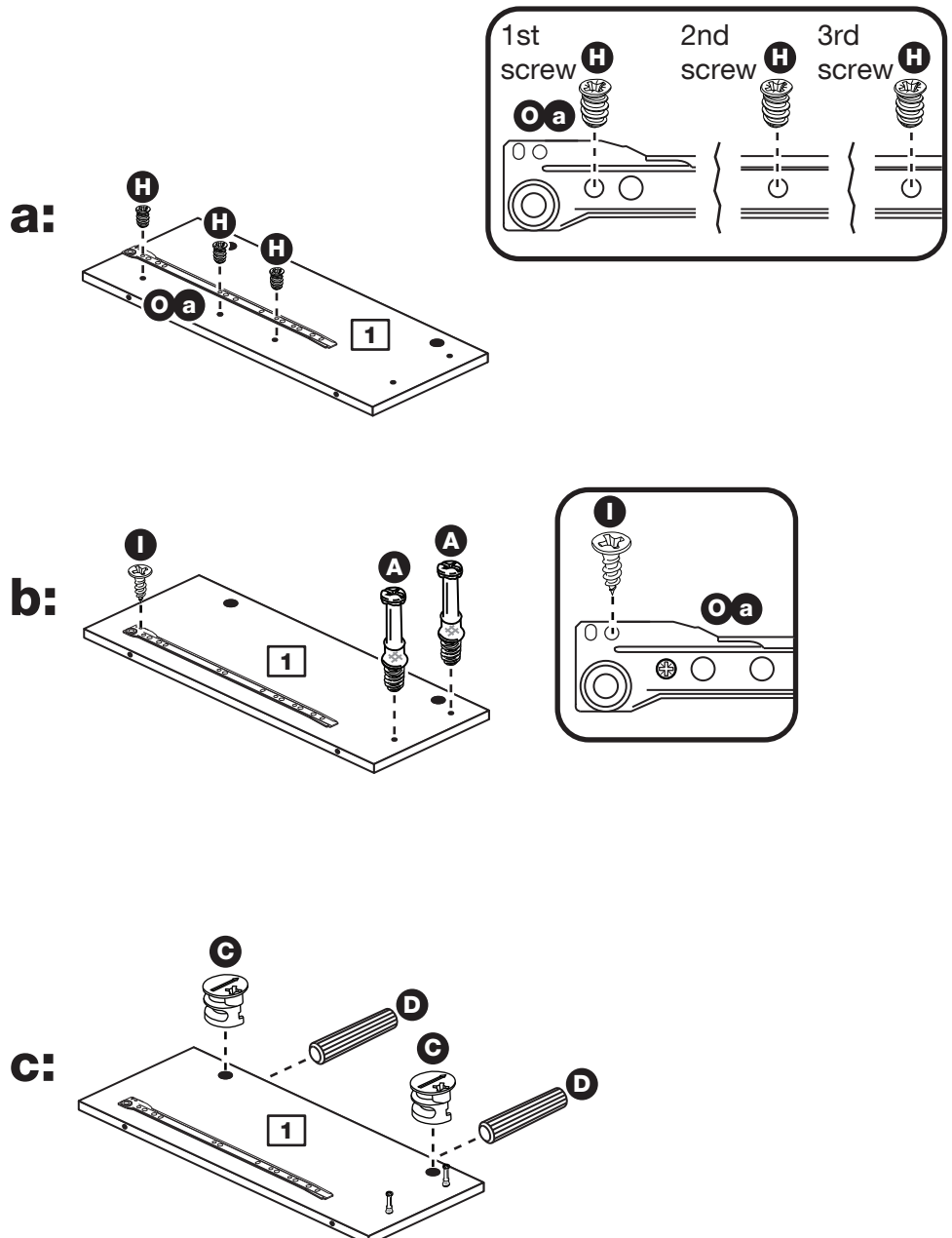

Assembly Instructions

Step 17

Fit the left end to the left back

Push the left end **1** onto the left back **7**.

Use a screwdriver to tighten the 2 large locking nuts **C** fitted to the left back **7**.

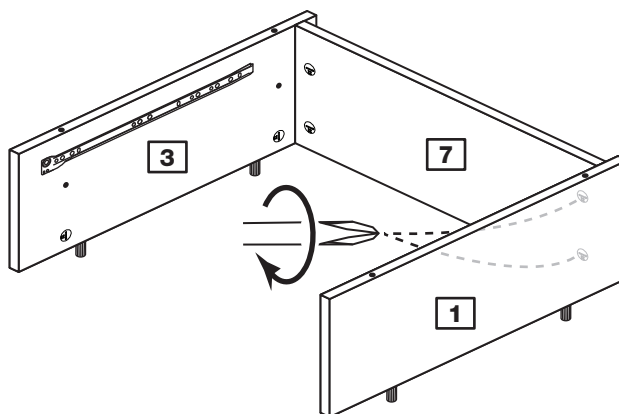

Step 18

Fit the left end and divider to the top

Push the left end **1** and divider **3** onto the top **4**.

Use a screwdriver to tighten the 4 large locking nuts **C** fitted to the left end **1** and divider **3**.

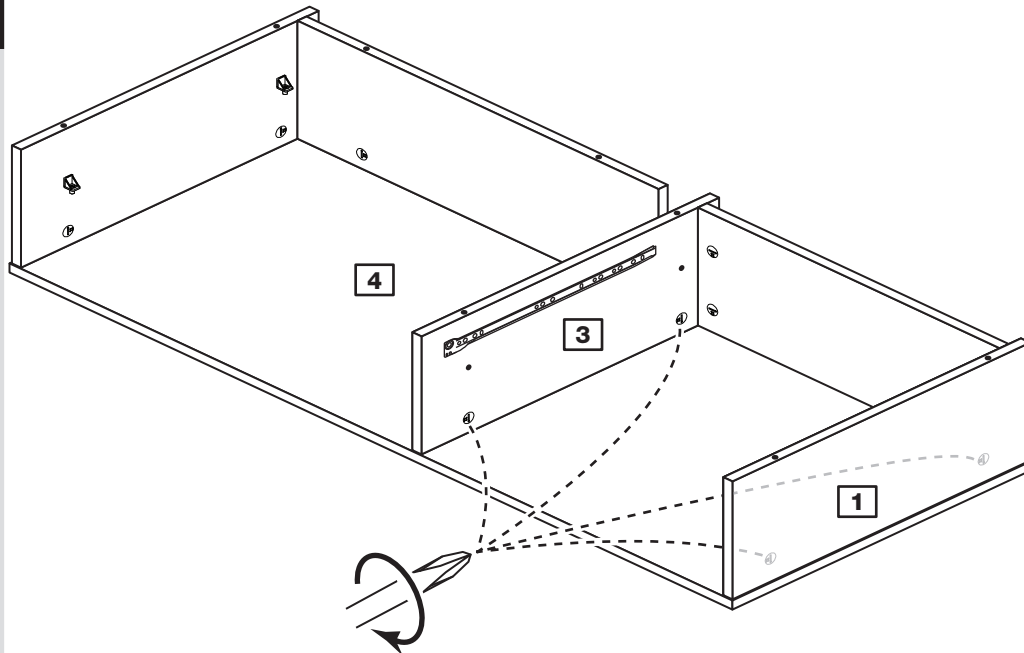

Assembly Instructions

Step 19

Fit the base

Attach the base **6** to the assembly using screws **F** and tighten them using the allen key **N**.

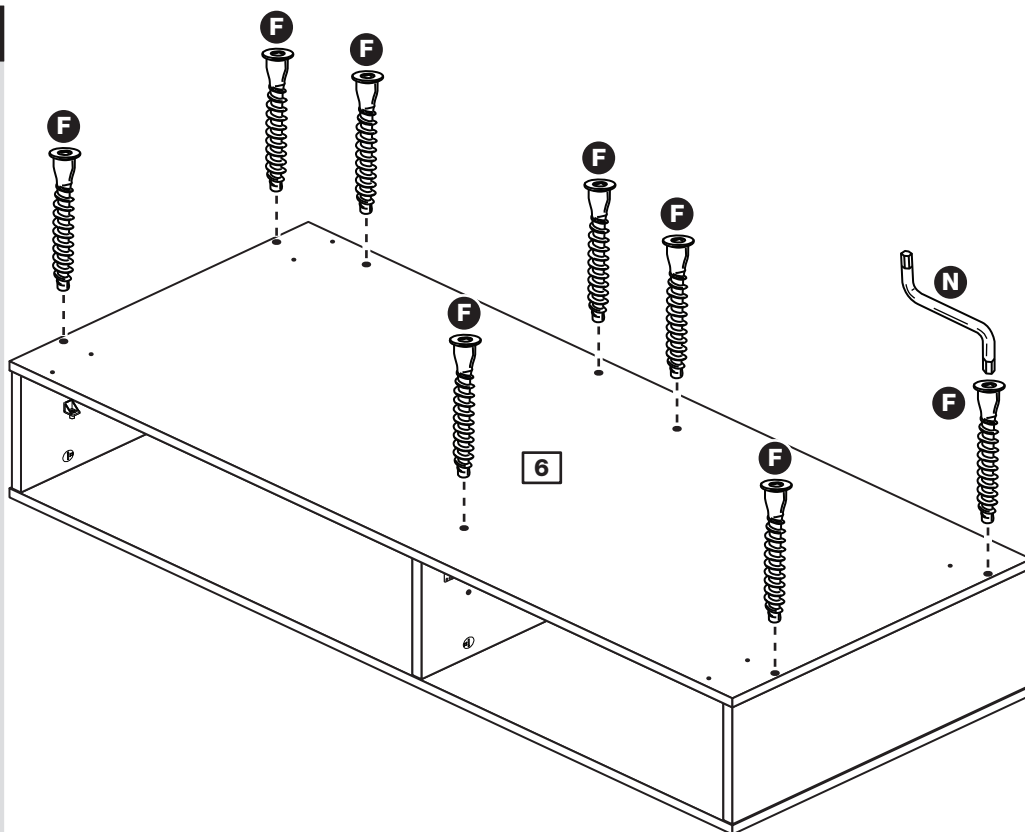

Step 20

Fit the leg brackets to the base

Screw each leg bracket **L** to the base **6** using 2 screws **G** into the mark holes.

Then use another 2 screws **G** into the other 2 holes.

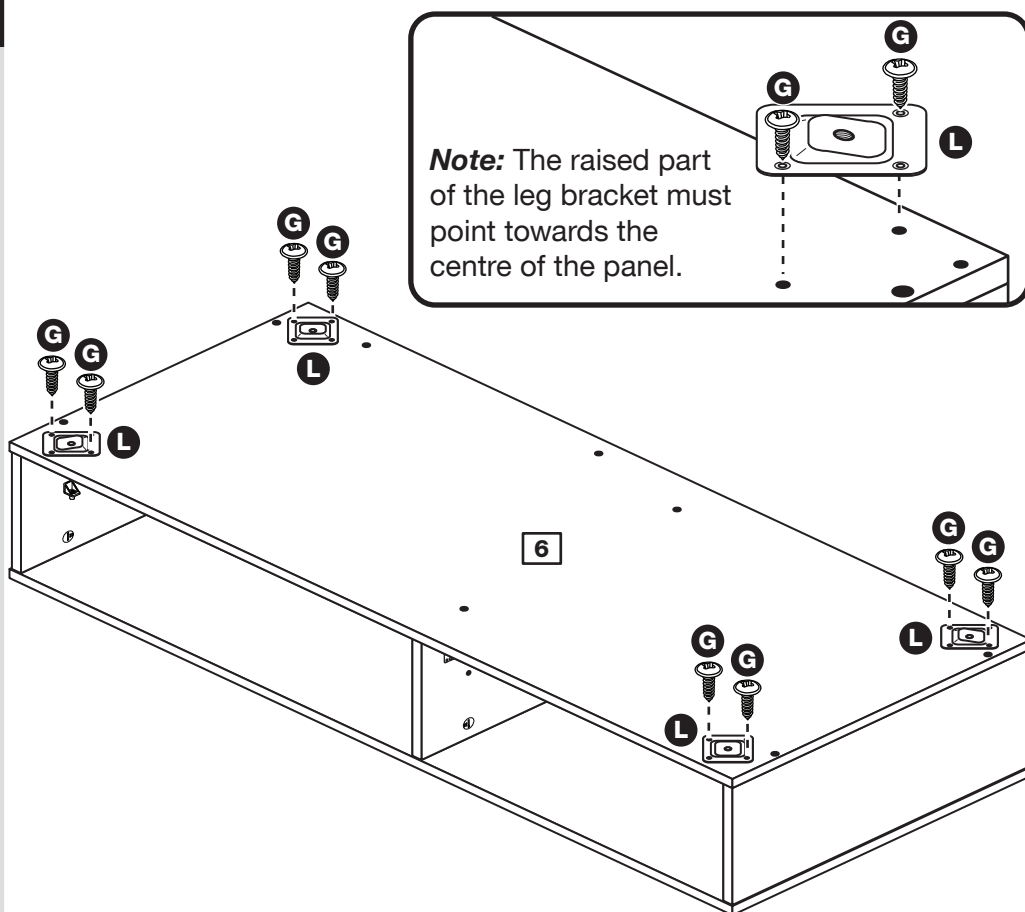

Assembly Instructions

Step 21

Fit the legs

Screw the legs **M** into the leg brackets **L**.

Carefully stand the unit up for the next step.



Warning: The unit is heavy. Lift with care.

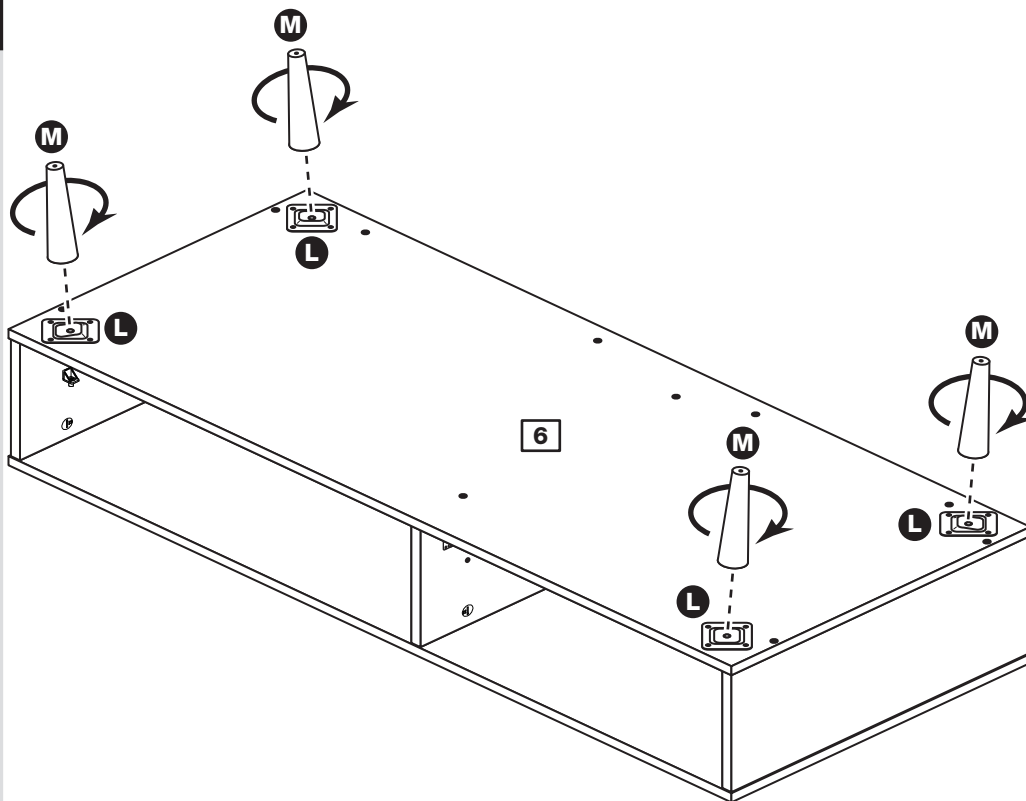

Step 22

Fit the shelf

Insert the shelf **5** and push it down onto the shelf studs **K**.

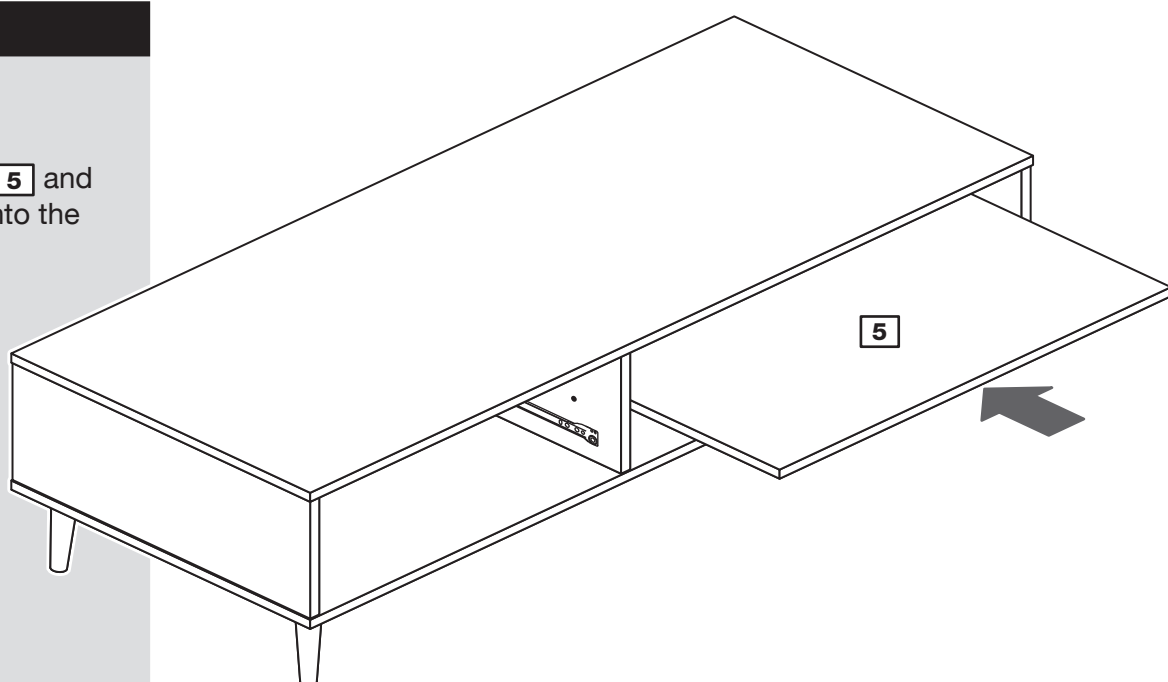

Assembly Instructions

Step 23

Fit the drawer

Slide the wheels of the runners fitted to the drawer, over the wheels of the runners fitted to the left side and divider, and push the drawer into position.

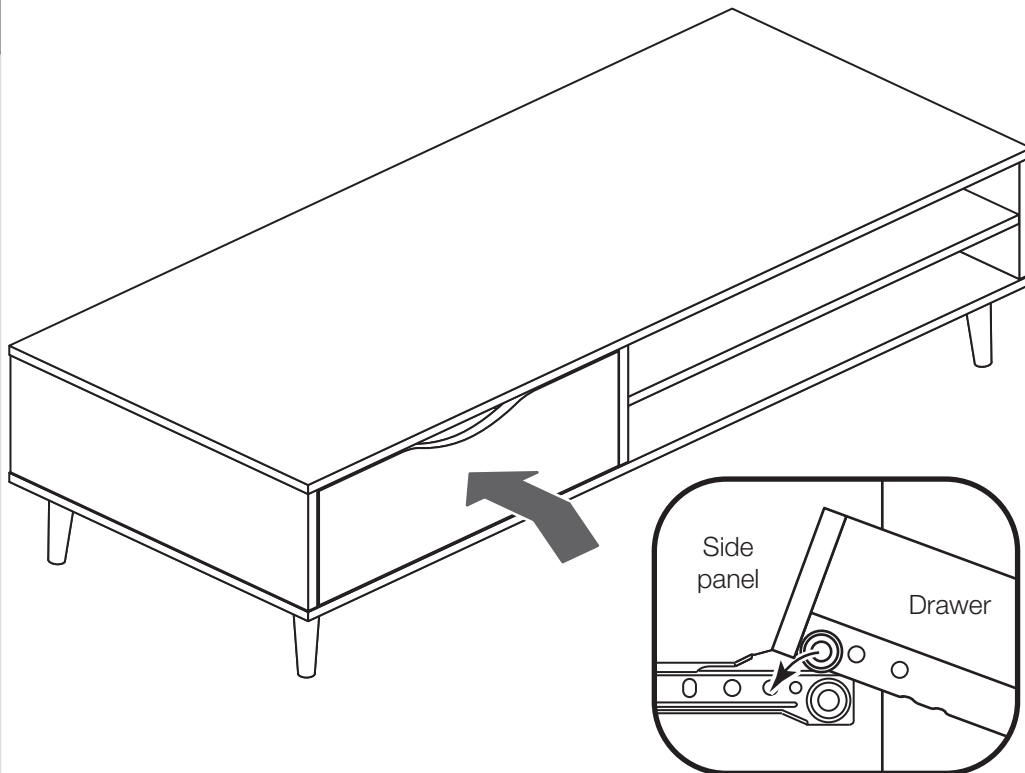

Step 24

Assembly is complete

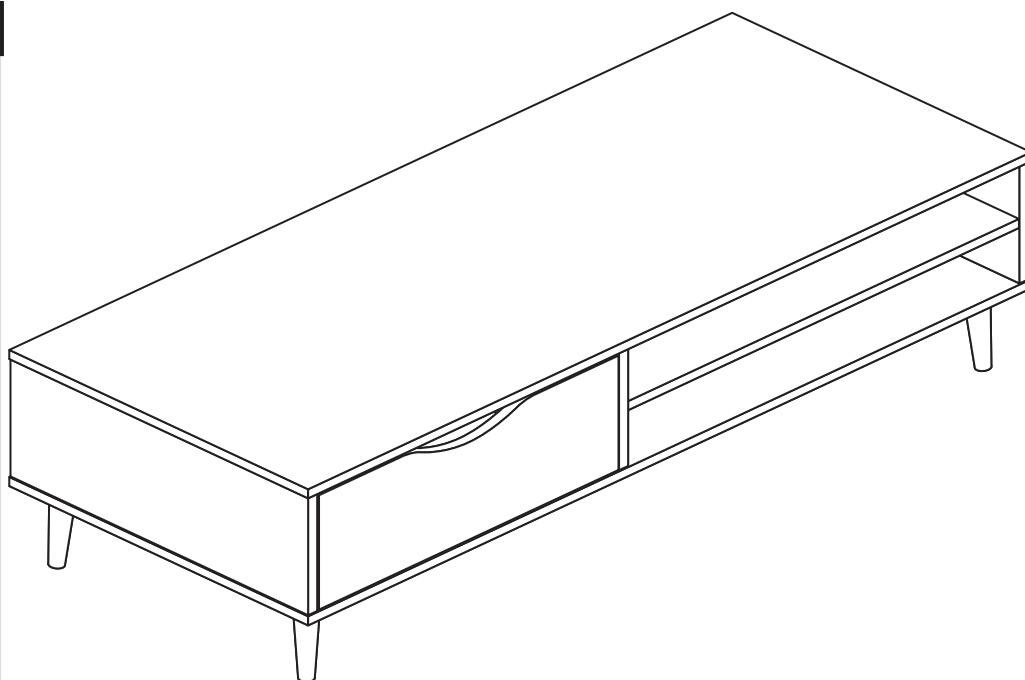

If you need help or have damaged or missing parts, call the **Customer Helpline: 03456 400800** and quote the reference numbers on the component pages.

Argos Ltd, 489-499 Avebury Boulevard, Central Milton Keynes, MK9 2NW

