



Air³

User Guide

U88-AM-B / U88-AM-P / U88-AM-R / U88-AM-T / U87-AM-C



Contents

Contents	1
Machine Overview	2
General Safety Information	3
Getting Started	4
How To Use	5
Looking After Your Machine – Filters	6
Looking After Your Machine – Removing Blockages	7
FAQs	8
Other Information	9
Guarantee	10

Machine Overview

- 1 Handle
- 2 Handle height adjuster
- 3 Handle release button
- 4 Dirt container release button
- 5 Carry handle
- 6 Power on/off button
- 7 Brushbar on/off button
- 8 Inner cyclones
- 9 Dirt container
- 10 Post-motor filter cover
- 11 Brushbar blockage indicator
- 12 Brushbar access clips
- 13 Rotating brushbar
- 14 Quick release cord wrap
- 15 Cord
- 16 Wheels
- 17 Brushbar reset button
- 18 Stretch hose
- 19 Telescopic extension tube
- 20 2-in-1 crevice tool and dusting brush
- 21 Upholstery tool
- 22 Pre-motor filter
- 23 Post-motor filter
- 24 TurboTool (Pet, Reach and Total Home models)
- 25 Flexi crevice tool (Reach and Total Home)

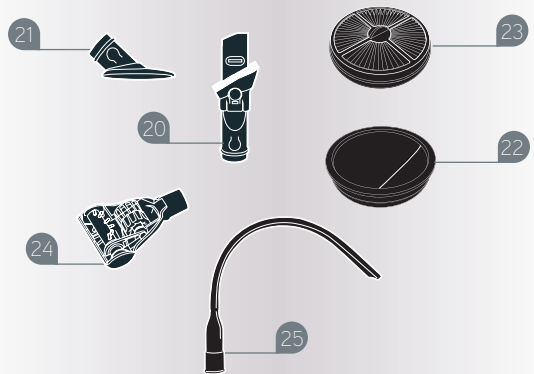
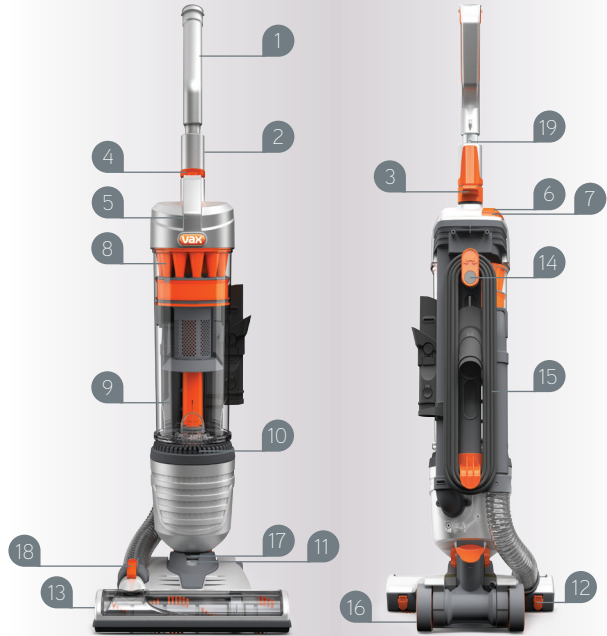

NOTE: Some parts may vary according to model. Please check inside flap of box for more details.

General Safety Information

This vacuum cleaner is intended for household use only and NOT for commercial or industrial use. Please keep instructions for further use.

When using the vacuum cleaner basic safety precautions should always be observed, including the following:

1. Only use the vacuum cleaner indoors on dry surfaces.
2. Turn off the on/off switch on the vacuum cleaner controls before disconnecting or connecting from the mains supply.
3. Always unplug the vacuum cleaner before connecting or disconnecting the vacuum hose and accessories.
4. Children should be supervised to ensure that they do not play with the appliance.
5. This appliance is not intended for use by children under eight years of age and persons with reduced physical, sensory or mental capabilities or lack of experience and knowledge, unless they have been given supervision or instruction concerning use of the appliance in a safe way and understands the hazards involved.
6. Cleaning and maintenance shall not be made by children without supervision.
7. The appliance should only be used as described in the quick start guide or in the full online user guide.
8. Only Vax recommended attachments should be used with this appliance.
9. Do not use this vacuum cleaner if it has been dropped, damaged, left outdoors or dropped into water. Do not use this vacuum cleaner with a damaged cord or plug. If the supply cord is damaged return the vacuum cleaner to Vax or an authorised Service Agent for examination, repair or adjustment.
10. Do not pull or carry this appliance by the cord. Do not use the cord as a handle, close a door on the cord or pull the cord around sharp edges or corners. Do not run the vacuum cleaner over the cord. Keep the cord away from heated surfaces.
11. Do not handle the plug or the vacuum cleaner with wet hands.
12. Keep hair, loose clothing, fingers and all parts of the body away from openings and moving parts.
13. Do not pick up any hot coals, cigarette butts, matches or any hot, smoking or burning objects.
14. Do not pick up any flammable or combustible materials (lighter fluid, petrol, kerosene etc.) or use in the presence of explosive liquids or vapours.
15. Do not vacuum up harmful or toxic material (chlorine, bleach, ammonia, drain cleaner etc.).
16. Do not vacuum up hard or sharp objects such as glass, nails, screws, coins etc.
17. Store the vacuum cleaner in a cool, dry area.
18. Use only CE approved 13 amp extension cords. Non-approved cords may overheat. Care should be taken to arrange the cord so that the cord cannot be tripped over.
19. Do not put any objects into openings. Do not use with any openings blocked and do not restrict airflow. Keep all openings free of dust, lint, hair or anything that might reduce airflow.
20. Do not use without all of the filters in place.
21. Take extra care when positioning the vacuum cleaner on the stairs.
22. Please ensure that the brushbar is turned off when you are vacuuming on the stairs.
23. Keep vacuuming area well lit.

Getting Started

PLEASE READ SAFETY INFORMATION BEFORE USE (p3)

Before plugging the cord into the electrical outlet, make sure the switch is in the 'off' position. Hold the vacuum cleaner firmly when starting and in use.

Assembling your upright

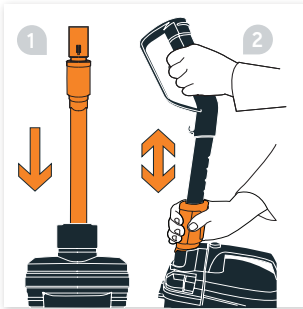

1. Insert the handle
2. Adjust handle up/down to the desired height

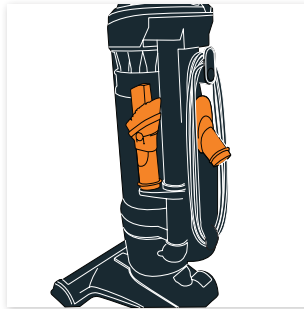

Attach the 2-in-1 and upholstery tool to their on board storage area.

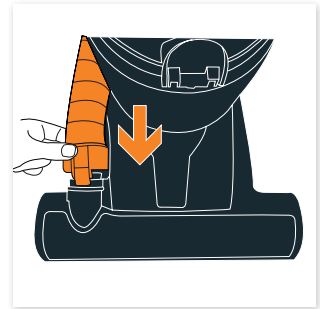

Attach the hose end to the floorhead ensuring it clicks into place. (All accessories can be used by either attaching them to the handle or the hose).

How to use

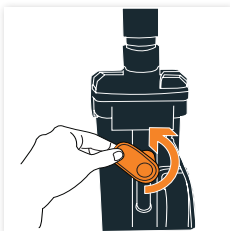

Twist the cord holder to release the cord.

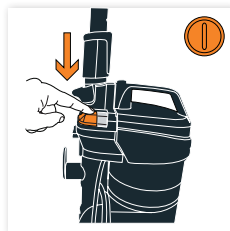

Plug in your machine and turn it on.

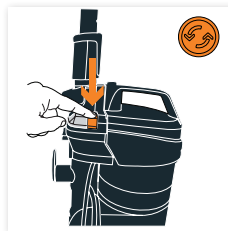

For brushbar position, press the brushbar on/off button at the top of the unit.
Brushbar on — carpets.
Brushbar off — hard floors.

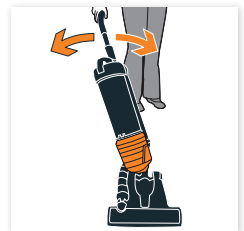

Recline the unit and twist the handle to manoeuvre under and around furniture.

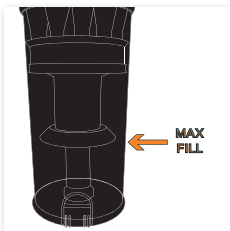

Don't over fill the container to avoid clogging your filters.

How To Use

Using accessories

NOTE: The 2-in-1 tool, TurboTool and other tools can be attached to the telescopic tube or directly to the hose.

NOTE: Switch off the brushbar before using any accessories/hose/telescopic extension tube.

Hose

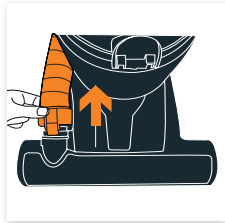

Remove hose.

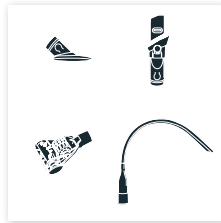

Choose an accessory.



Attach accessory to hose.

Telescopic extension tube

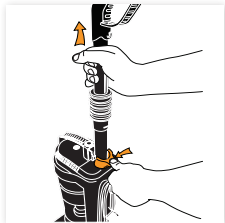

Remove telescopic extension tube.

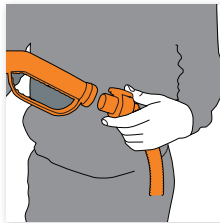

Attach hose to telescopic extension tube.

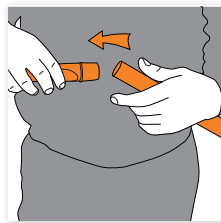

Attach accessory to telescopic extension tube.



IMPORTANT: Hold unit when using hose or telescopic extension tube for above floor cleaning.

Stair cleaning (Pet, Reach, Total Home models)

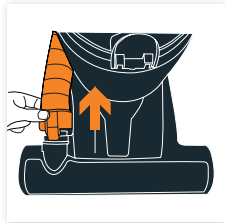

Remove stretch hose.

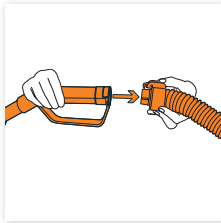

Attach stretch hose to telescopic extension tube.



Now you can easily clean the full height of your stairs.

Looking After Your Machine – Filters

WARNING: Always switch off and unplug the vacuum cleaner from the electrical socket before assembling, opening or emptying the dirt container, or before connecting/disconnecting the attachments.

IMPORTANT: Wash filters with warm water (40°C max) at least every 3 months for best cleaning results. Do not use your vacuum cleaner without all of the filters in place.

IMPORTANT: The motor is equipped with a thermal cut-out. If for any reason the unit should overheat, the thermostat will automatically turn the unit off.

Emptying and cleaning the dirt container



Press dirt container release button to remove the dirt container.



Hold dirt container over a bin and press dirt release button to open, allowing dirt to fall out.

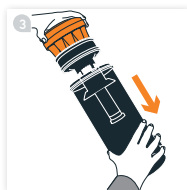

Cleaning the pre-motor filter

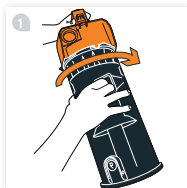

Turn the dirt container lid anti-clockwise to remove.

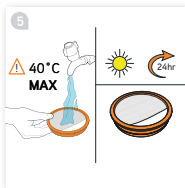

Cleaning the HEPA post-motor filter

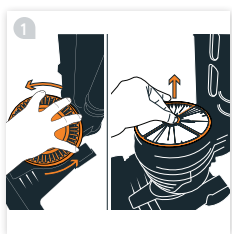

Remove the post-motor filter from the body of the vacuum cleaner.



Looking After Your Machine – Removing Blockages

IMPORTANT: If the air inlet, hose or telescopic tube is blocked, switch off the vacuum cleaner and remove the blockage(s) before re-starting the vacuum cleaner.

Re-setting the brushbar

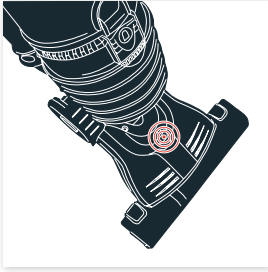

A **RED** flashing light will indicate a jammed brushbar.

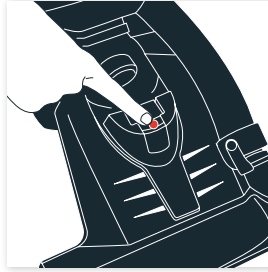

To reset press the **RED** button in the middle of the floorhead.

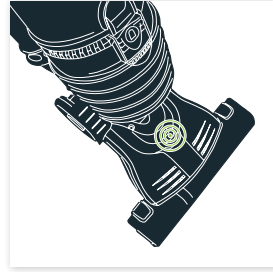

A **GREEN** flashing light indicates no blockages in the brushbar.

Removing debris from the brushbar

NOTE: Brushbar and belt are not removable

If the light continues to flash red after resetting, the brushbar may still be blocked. Using a pair of scissors, cut through any threads or hairs caught around the brushbar. To access brushbar:

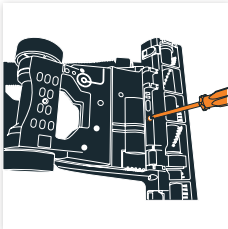

Place the vacuum cleaner on the floor upside down and remove the screw on the back of the brushbar cover.

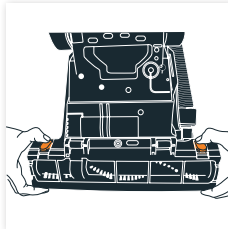

Unclip both clips on the brushbar cover.

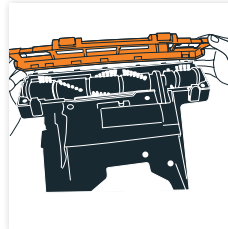

Remove the brushbar cover and remove debris, hair and dirt from the brushbar and belt.



Press the brushbar reset button again to ensure the blockage is fully cleared.

Removing blockages from the TurboTool

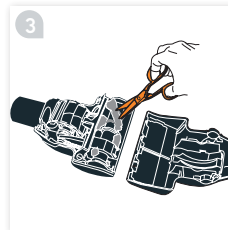
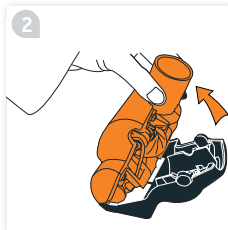
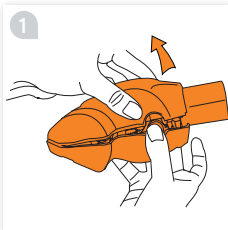

Warning: To reduce the risk of personal injury, unplug the vacuum cleaner before performing maintenance/troubleshooting checks.

Is there an accessory missing?

- Check the 'Getting Started' page in this guide or the box that the machine came in to make sure that the part is definitely included in your unit.
- If it is missing, we're here to help. Simply call us on **0844 412 8455**

Why won't the vacuum cleaner pick up?

- The filters may need cleaning, please refer to the 'Looking After Your Machine – Filters' page of this user guide (p6)
- The separator may be clogged, please refer to the 'Looking After Your Machine – Filters' page of this user guide (p6)
- There may be a blockage in the hose, please check the hose and remove the blockage
- The dirt container may be full or blocked, please refer to the 'Looking After Your Machine – Emptying and cleaning dirt container' page of this user guide (p6)
- The dirt container may be incorrectly installed, please ensure the dirt container is locked in place
- The brushbar may not be turning, please refer to the 'Looking After Your Machine – Removing Blockages' page in this user guide (p7)

Why won't the accessories pick up properly?

- The TurboTool may be blocked, please refer to the 'Looking After Your Machine – Removing Blockages' page in this user guide (p7)
- The accessory may be broken

What do I do if an accessory/the unit becomes damaged or broken?

- Please check if the damage is with the accessory or the unit. To do this, firstly remove the accessory from the unit and check if there is suction from the hose. If there is suction from the hose this confirms that the damage is with the accessory.
Please visit 'spares shop website' – vax.co.uk/support
- If having done the above checks, checked the hose for blockages and cleaned the filters there is still no suction/limited suction from the hose, please call our Vax Careline 0844 412 8455

Why is dust escaping from the vacuum?

- The filters may not be installed correctly, please refer to the 'Looking After Your Machine – Filters' page of the user guide (p6)
- The dirt container may be full or blocked, please refer to the 'Looking After Your Machine – Emptying and cleaning dirt container' page of this user guide (p6)
- The filters may need cleaning, please refer to the 'Looking After Your Machine – Filters' page of this user guide (p6)
- There may be a blockage in the hose, please check the hose and remove the blockage

Why does my vacuum cleaner have no power?

- It may not be plugged into the electrical socket correctly. Ensure that the plug is pushed into the electrical socket securely
- The electrical socket may not be working. Check the fuse or breaker and consult an electrician
- The motor thermostat may have tripped. Switch off and unplug the vacuum cleaner. Check the unit for blockages, clean the filters – please refer to the 'Looking After Your Machine – Filters' page of this user guide (p6) and clean the separator (please refer to the 'Looking After Your Machine – Emptying and cleaning dirt container' page of this user guide (p6)). Leave the vacuum cleaner for 24 hours before switching the vacuum cleaner back on

Why isn't my brushbar rotating?

- The brushbar may not be turned on. Please refer to the 'Getting Started' page of this user guide (p4)
- The unit may not be reclined. Please refer to the 'Getting Started' page of this user guide (p4)
- The brushbar may be jammed. Please refer to the 'Looking After Your Machine – Removing Blockages' page of this user guide and remove any blockages (p7)
- The brushbar may need re-setting. Please refer to the 'Looking After Your Machine – Removing Blockages' page of this user guide (p7)

Why is there a red light on my floorhead?

- The brushbar may be jammed. Please refer to the 'Looking After Your Machine – Removing Blockages' page of this user guide (p7)
- If the brushbar has been checked for blockages and the light still on, we're here to help. Call us on 0844 412 8455

Why does the vacuum cleaner cut out?

- The motor is equipped with a thermal cut-out. If for any reason the unit should overheat, the thermostat will automatically turn the unit off. Should this occur, unplug the vacuum cleaner from the electrical socket and turn off the switch. Remove and empty the dirt container. Check the hose for blockages. Clean the filters. Allow the unit to cool for approximately 1 hour (if you have cleaned the filters you will need to wait 24 hours for the filters to dry before putting them back in the machine)

What do I do if the unit becomes damaged or broken?

- We're here to help. Simply call **0844 412 8455** or visit vax.co.uk

Other Information

UK Service & Help

Any queries or concerns about using your Vax, simply visit; vax.co.uk/support – vaxireland.ie or call the Vax Careline. Calls are charged at the UK local rate. Please make a note of the serial number and model number of the vacuum cleaner before calling.

Vax Careline:
(UK) 0844 412 8455
(ROI) 1-800 928 308

Monday-Friday 8.30am to 6.30pm
Saturday 9.00am to 5.00pm

Consumables

To purchase spares and accessories, please visit vax.co.uk

The use of genuine vax spare parts helps to maintain optimised performance and validates your guarantee

Filter kit (Type 60): 1-1-132030-00
2-in-1 tool (Type 2): 1-1-132115-00
Upholstery tool (Type 3): 1-1-132116-00
TurboTool (Type 1): 1-1-126261-00
Flexi crevice tool (Type 1): 1-1-131393-00

Technical Specification

Voltage: 220-240V -50Hz
Filters: Pre-motor filter (washable)
H12 HEPA (anti-bacterial) Post-motor filter

Subject to technical change without notice.



EEC Statement of Compliance

Manufacturer/EEC importer: Vax Limited, hereby on our own responsibility, declare that the **U88-AM** series is manufactured in compliance with the following Directives:

Safety: 2006/95/EC Low Voltage Directive

EMC: 2004/108/EC Electromagnetic Compatibility Directive



Waste electrical products should not be disposed of with household waste. Please recycle where facilities exist. Check with your Local Authority or retailer for recycling advice.



For best performance
Protect your guarantee

It's quick and easy to register for your
FREE 6 year guarantee
online at: vax.co.uk/guarantees

Please retain your original receipt for proof of purchase.

UK based customer care centre — Open 6 days a week

Monday-Friday	8:30am-18:30pm
Saturday	9:00am-17:00pm

we're here if you need us

Instead of taking me back to the shop, simply visit:
vax.co.uk/support or call (UK) 0844 412 8455 (ROI) 1-800 928 308

Let us know what you think @VaxUK 



6 year
guarantee



For best performance
Protect your guarantee



V1.2

Vax Ltd., Kingswood Road, Hampton Lovett, Droitwich, Worcestershire, WR9 0QH, UK
email: info@vax.co.uk website: vax.co.uk