

Assembly Instructions

Step 1

Chair assembly

a: Open the underside of the padded Seat **2** as shown in the picture.

Fix the Seat **2** and the Backrest **3** with the 5 Screws **C** through Washers **B** and **A**, using the Imbus key supplied.

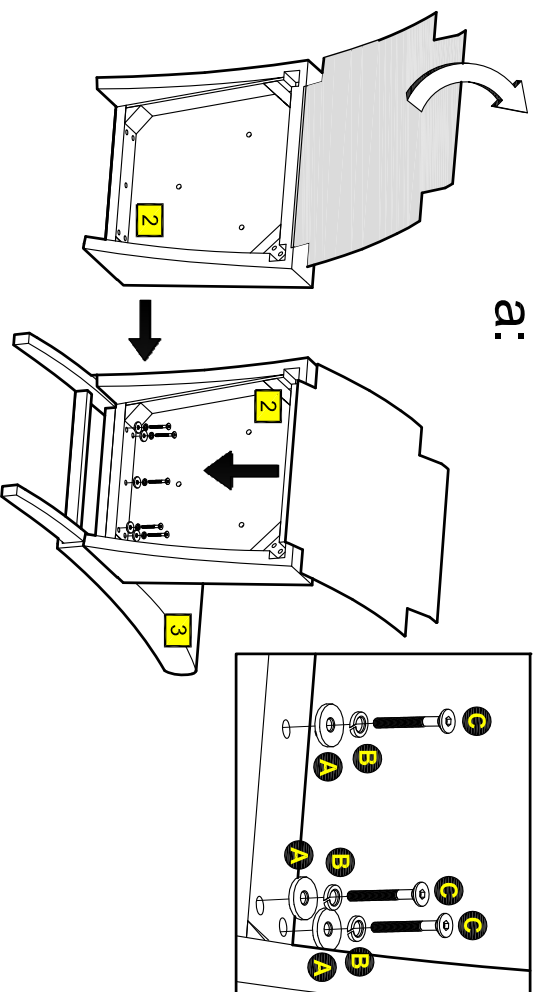

b: Insert the Leg **1** into the Seat **2**. Fix the leg with 2 Screws **C** through Washers **B** and **A**, using the Imbus key supplied.

Make the same for the other leg.

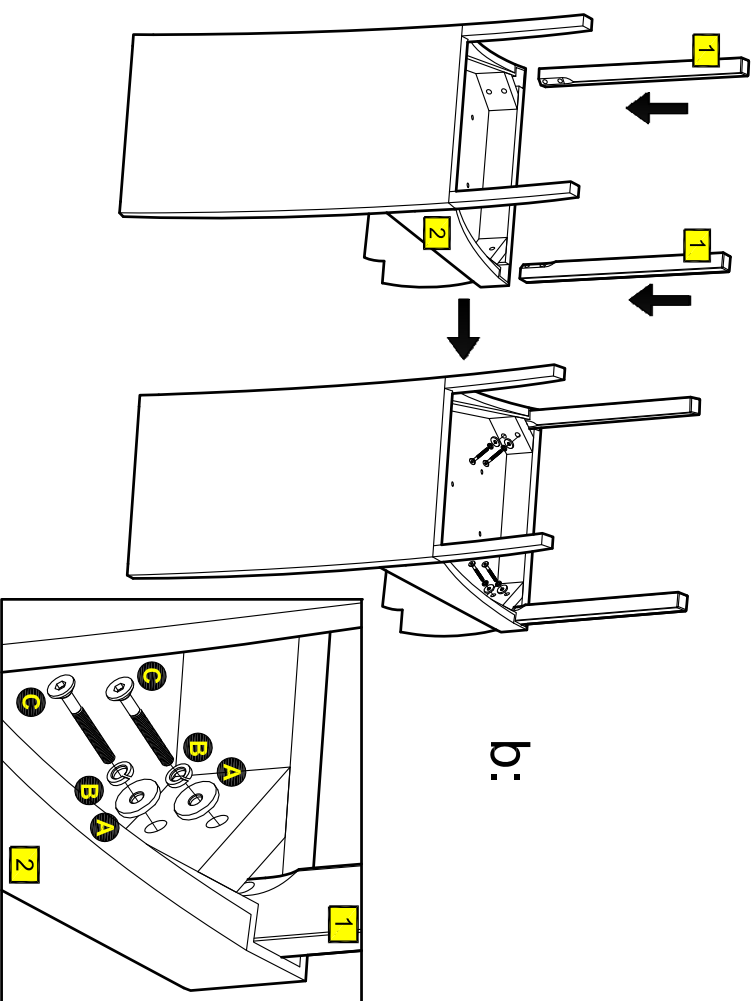

c: Close the bottom of the seat **2** as shown in picture.

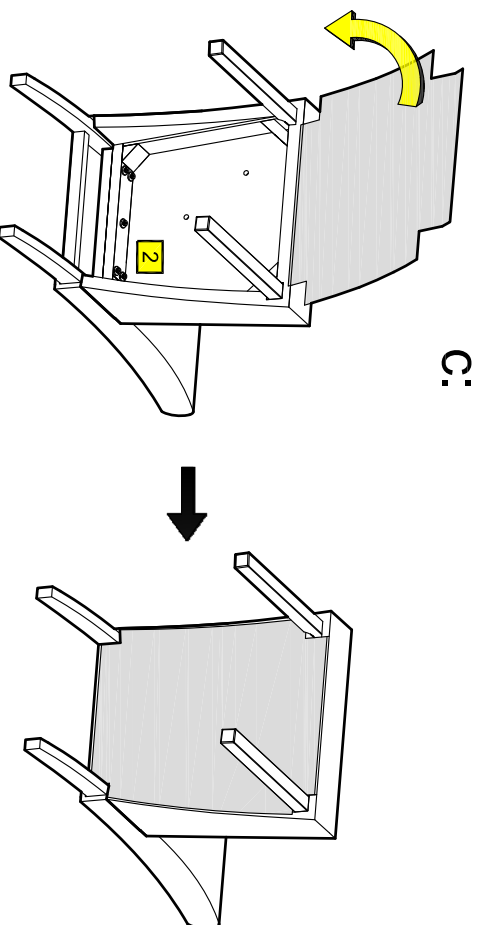

Assembly is complete.

Skirted Chair

Assembly Instructions - Please keep for future reference



259 / 3955
247 / 6728
248 / 2262

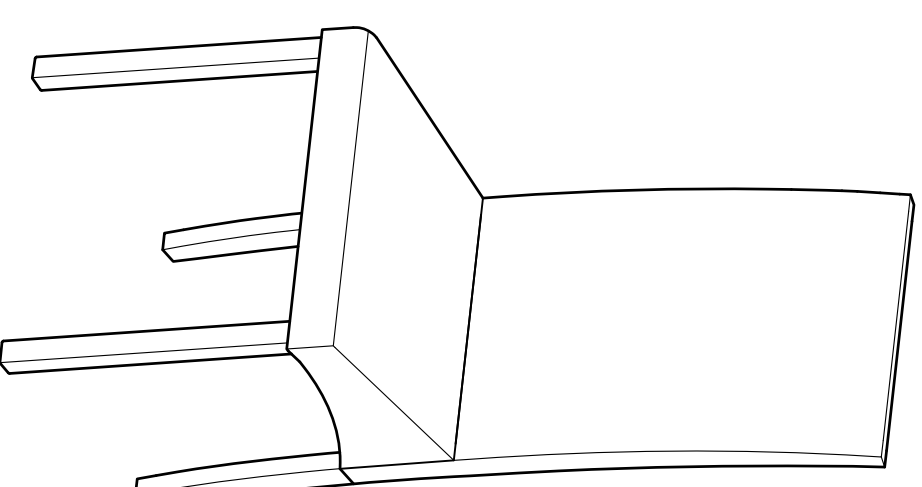

Dimensions

Width - 45cm
Depth - 53cm
Height - 95cm

Important - Please read these instructions fully before starting assembly

If you need help or have damaged or missing parts, call the Customer Helpline:

Argos = 0835 6400800

⚠ Safety and Care Advice

Important - Please read these instructions fully before starting assembly

- We suggest you spend a short time reading through this leaflet and follow the simple step by step assembly instructions.
- Do not discard any of the packaging until you have checked that you have all the parts and the pack of fittings.
- Assemble this product on a flat surface.
- Assemble all parts loosely before tightening any bolts.
- Discard all extra fittings and keep fittings out of reach of children.
- Unit weight: 5kgs.
- Retain Assembly Instructions for future reference.
- We do not recommend the use of power drill/drivers for inserting screws as this could damage the unit.
- Only use hand screwdrivers.
- Dispose of all packaging carefully and responsibly.



Warnings

- This product should only be used on firm, level ground.
- Do not use any abrasive materials when cleaning.
- From time to time check that there are no loose bolts on this unit.

Care and maintenance

IMPORTANT MAINTENANCE AND CLEANING INFORMATION DO NOT REMOVE (CARING FOR YOUR PRODUCT)

Outlined below are general care instructions that will prolong the look and life by preventing wear and damage.

PLEASE NOTE THAT THE MANUFACTURER IS NOT LIABLE FOR ANY DEFECTS CAUSED BY MISUSE, NON COMPLIANCE WITH THESE INSTRUCTIONS

PU - PVC etc.

General Care Advice

- Dust regularly with a clean dry cloth.
- Wipe up any liquid spills immediately with a damp cloth and then dry the surface with a clean dry duster.
- Repeat this procedure for periodic cleaning.
- Solid spills (Butter, Food & Mud) - Remove excess with a blunt Knife before dabbing to clean stains.
- The use of furniture polish or spray is not necessary or recommended.

What Not To Do - Do Not Soak

- Never rub or scrub with a wet cloth to remove spills or stains as this could remove colour.
- Do not use washing up liquid, detergents, or bleach to remove stains.

Cleaning:

We recommend Professional Cleaning only for this product, to prevent excessive build-up of dirt and soiling.

Sunlight and Heat

- Direct sunlight or heat can cause fabrics to deteriorate or fade - Place your furniture out of the way of prolonged direct light.
- Reduce exposure by moving items around or changing position so that the same piece of area is not always exposed.
- Avoid placing furniture too close to fires or radiators

Beware of Sharp objects

Sharp objects such as buckles and jewellery can easily snag on the fabric and produce tears and marks in the fabric.

Components - Parts

If you have damaged or missing components, call the Customer Helpline: Argos = 0835 6400800

Please check you have all the parts listed below

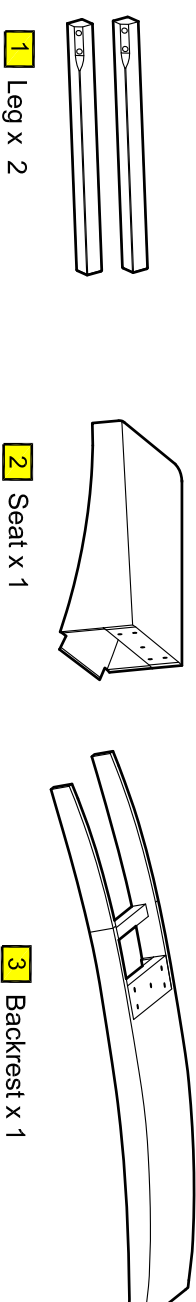

Components - Fittings

Please check you have all the parts listed below

Note: the quantities below are the correct amount to complete the assembly. In some cases more fittings may be supplied than are required.

A		B		C	
	M6x18 Plain Washer x 9		M6 Lock Washer x 9		M6x60mm Bolt x 9

Please check you have all the parts listed below

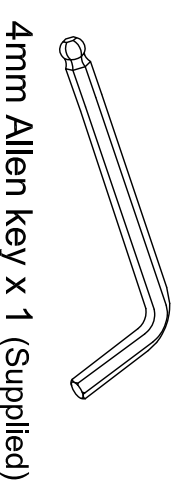

Assembly Instructions

Step 1

Chair assembly

a: Open the underside of the padded Seat **2** as shown in the picture.

Fix the Seat **2** and the Backrest **3** with the 5 Screws **C** through Washers **B** and **A**, using the Imbus key supplied.

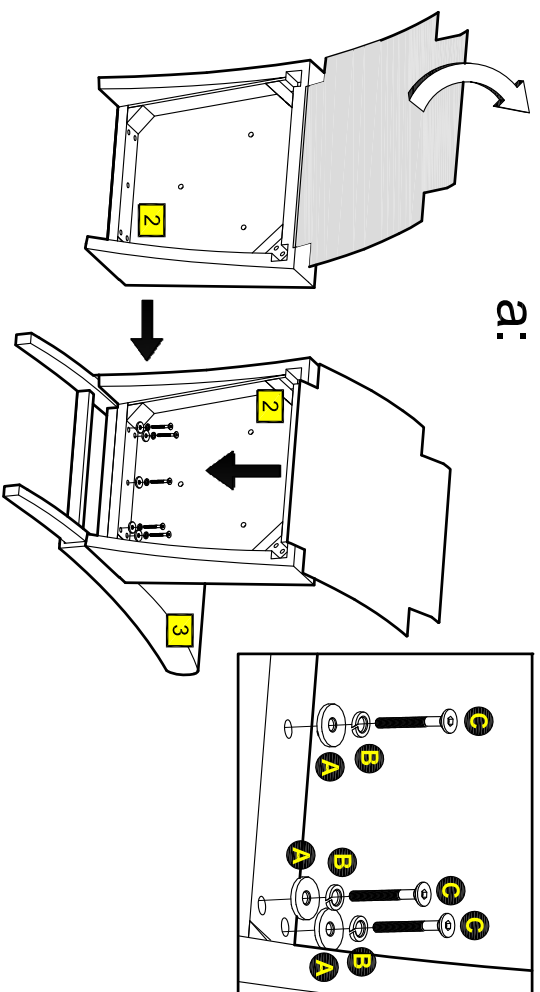

b: Insert the Leg **1** into the Seat **2**. Fix the leg with 2 Screws **C** through Washers **B** and **A**, using the Imbus key supplied.

Make the same for the other leg.

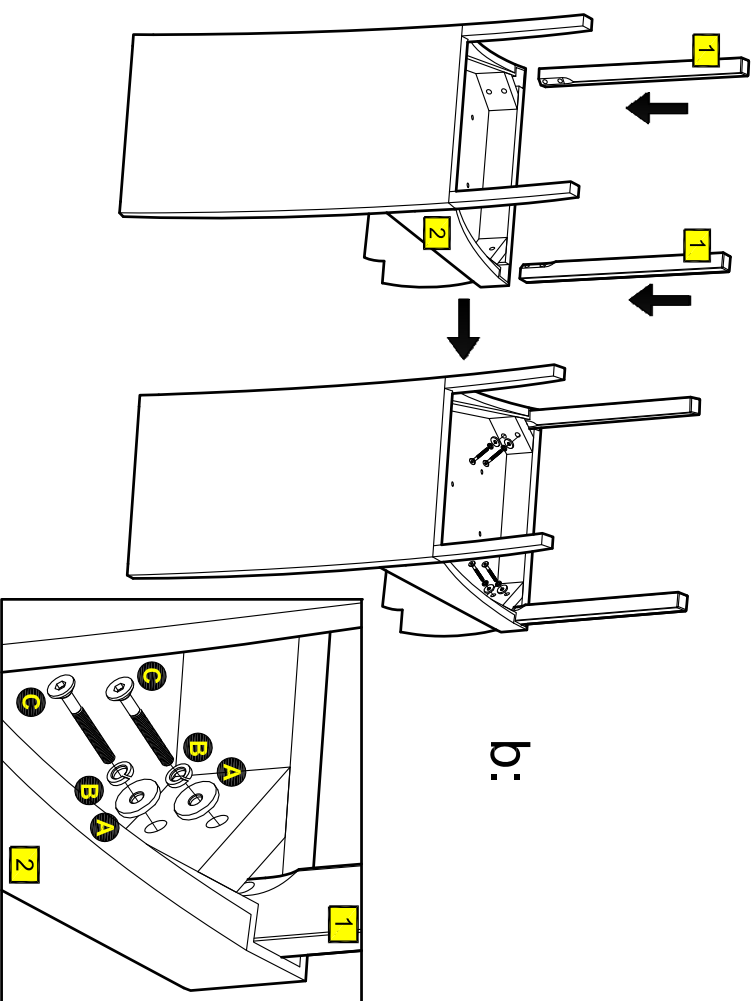

c: Close the bottom of the seat **2** as shown in picture.

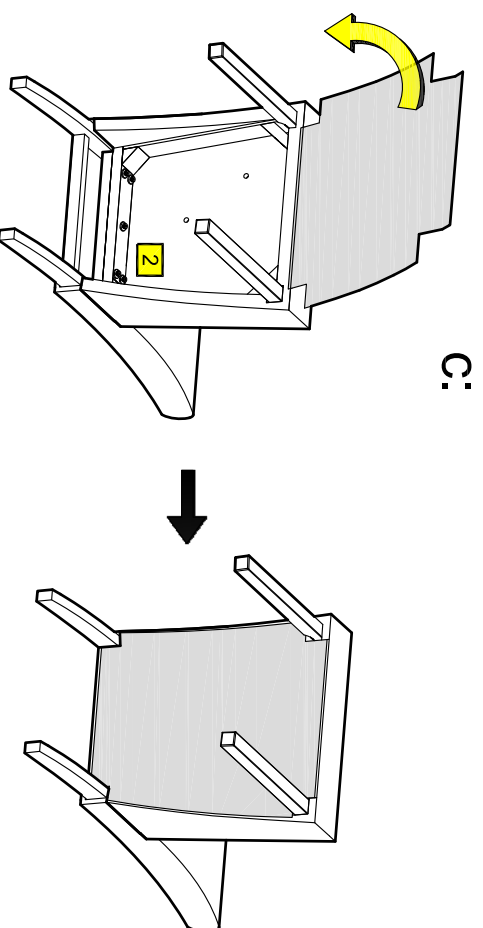

Assembly is complete.

Skirted Chair

Assembly Instructions - Please keep for future reference



259 / 3955
247 / 6728
248 / 2262

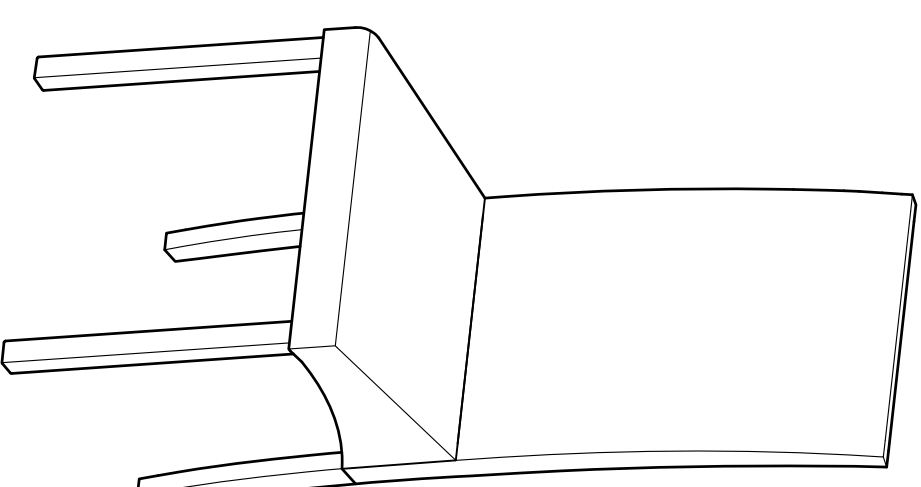

Dimensions

Width - 45cm
Depth - 53cm
Height - 95cm

Important - Please read these instructions fully before starting assembly

If you need help or have damaged or missing parts, call the Customer Helpline:

Argos = 0835 6400800

⚠ Safety and Care Advice

Important - Please read these instructions fully before starting assembly

- We suggest you spend a short time reading through this leaflet and follow the simple step by step assembly instructions.
- Do not discard any of the packaging until you have checked that you have all the parts and the pack of fittings.
- Assemble this product on a flat surface.
- Assemble all parts loosely before tightening any bolts.
- Discard all extra fittings and keep fittings out of reach of children.
- Unit weight: 5kgs.
- Retain Assembly Instructions for future reference.
- We do not recommend the use of power drill/drivers for inserting screws as this could damage the unit.
- Only use hand screwdrivers.
- Dispose of all packaging carefully and responsibly.



Warnings

- This product should only be used on firm, level ground.
- Do not use any abrasive materials when cleaning.
- From time to time check that there are no loose bolts on this unit.

Care and maintenance

IMPORTANT MAINTENANCE AND CLEANING INFORMATION DO NOT REMOVE (CARING FOR YOUR PRODUCT)

Outlined below are general care instructions that will prolong the look and life by preventing wear and damage.

PLEASE NOTE THAT THE MANUFACTURER IS NOT LIABLE FOR ANY DEFECTS CAUSED BY MISUSE, NON COMPLIANCE WITH THESE INSTRUCTIONS

PU - PVC etc.

General Care Advice

- Dust regularly with a clean dry cloth.
- Wipe up any liquid spills immediately with a damp cloth and then dry the surface with a clean dry duster.
- Repeat this procedure for periodic cleaning.
- Solid spills (Butter, Food & Mud) - Remove excess with a blunt Knife before dabbing to clean stains.
- The use of furniture polish or spray is not necessary or recommended.

What Not To Do - Do Not Soak

- Never rub or scrub with a wet cloth to remove spills or stains as this could remove colour.
- Do not use washing up liquid, detergents, or bleach to remove stains.

Cleaning:

We recommend Professional Cleaning only for this product, to prevent excessive build-up of dirt and soiling.

Sunlight and Heat

- Direct sunlight or heat can cause fabrics to deteriorate or fade - Place your furniture out of the way of prolonged direct light.
- Reduce exposure by moving items around or changing position so that the same piece of area is not always exposed.
- Avoid placing furniture too close to fires or radiators

Beware of Sharp objects

Sharp objects such as buckles and jewellery can easily snag on the fabric and produce tears and marks in the fabric.

Components - Parts

If you have damaged or missing components, call the Customer Helpline: Argos = 0835 6400800

Please check you have all the parts listed below

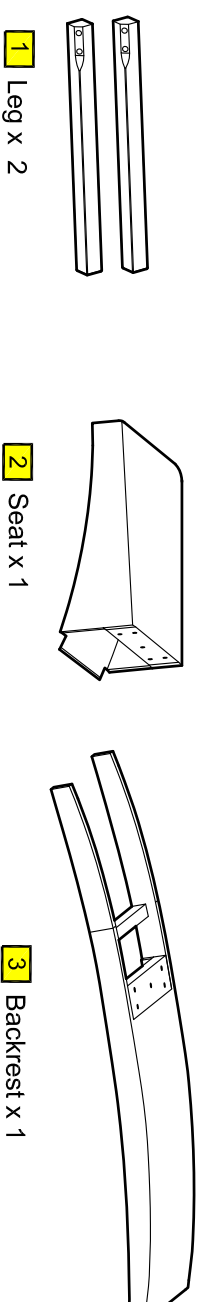

1 Leg x 2

2 Seat x 1

3 Backrest x 1

Components - Fittings

Please check you have all the parts listed below

Note: the quantities below are the correct amount to complete the assembly. In some cases more fittings may be supplied than are required.

A		B		C	
	M6x18 Plain Washer x 9		M6 Lock Washer x 9		M6x60mm Bolt x 9

Please check you have all the parts listed below

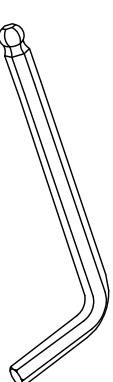

4mm Allen key x 1 (Supplied)

Penley Extendable Table

Assembly Instructions - Please keep for future reference

330/8888

239/7694

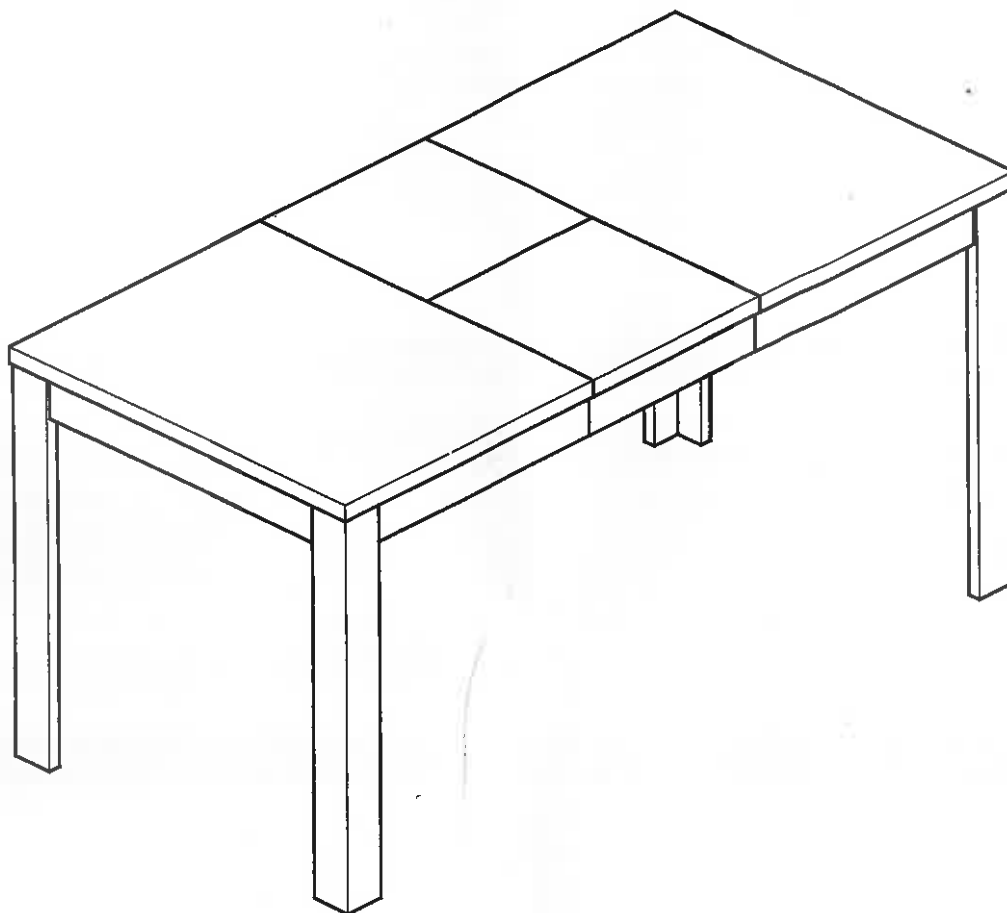

Dimensions

Width - 120 (160)cm
Depth - 80cm
Height - 75cm

Important – Please read these instructions fully before starting assembly

If you need help or have damaged or missing parts, call the Customer Helpline: 0345 640 0800



Safety and Care Advice

Important – Please read these instructions fully before starting assembly

- Check you have all the components and tools listed on page 2 and 3.
- Remove all fittings from the plastic bags and separate them into their groups.
- Keep children and animals away from the work area, small parts could choke if swallowed.
- Make sure you have enough space to layout the parts before starting.
- During assembly do not stand or put weight on the product, this could cause damage.
- Assemble the item as close to its final position (in the same room) as possible.
- Assemble on a soft level surface to avoid damaging the unit or your floor.
- Parts of the assembly will be easier with 2 people.
- To reduce the likelihood of damaging your product please ensure that your power drill is set on a low torque setting.
- Dispose of all packaging carefully and responsibly.



Care and maintenance

- Only clean using a damp cloth and mild detergent, do not use bleach or abrasive cleaners.
- From time to time check that there are no loose screws on this unit.
- This product should not be discarded with household waste. Take to your local authority waste disposal centre.

Handy Hints

- Assemble all parts and bolts loosely during assembly, only once the product is complete should you fully tighten the bolts.
- Regularly check and ensure that all bolts and fittings are tightened properly.

Components - Parts

If you have damaged or missing components,
call the Customer Helpline: 0345 640 0800

Please check you have all the parts listed below

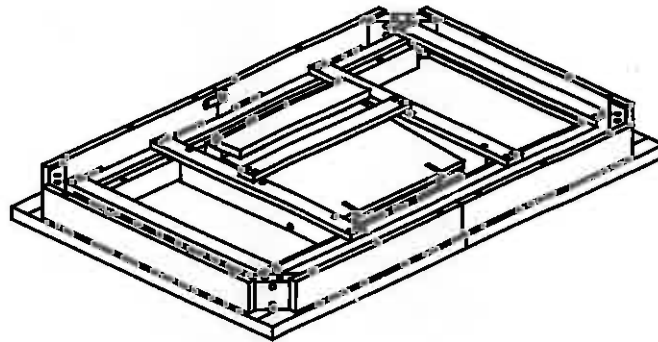

1 Table top x 1

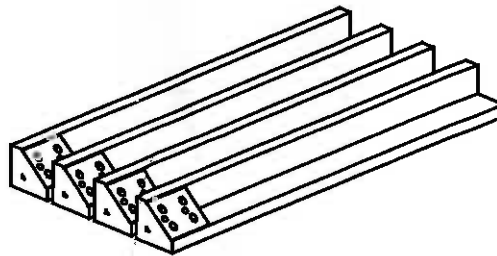





2 Leg x 4

Components - Fittings

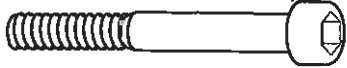
Please check you have all the fittings listed below

Note :The quantities below are the correct amount to complete the assembly. In some cases more fittings may be supplied than are required.

<p>A </p> <p>Bolt x 8</p>	<p>B </p> <p>Spring washer x 8</p>	<p>C </p> <p>Washer x 8</p>
<p>D </p> <p>Ball allenkey x 1</p>		

Assembly Instructions

Step 1

Place table top upside down being careful to not scratch the table top surface (Leaving the product within its cardboard packaging will assist you in being able to do this)

a: To release the safety locks.

a:

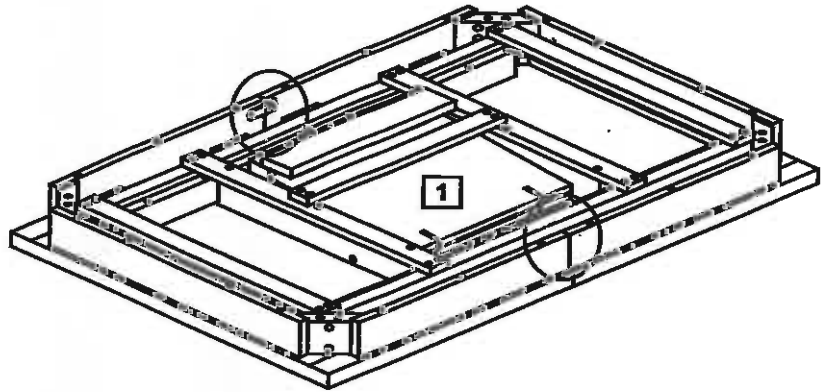

b: To pull the table tops out a little and provide the space for installation of legs as shown by arrows.

b:

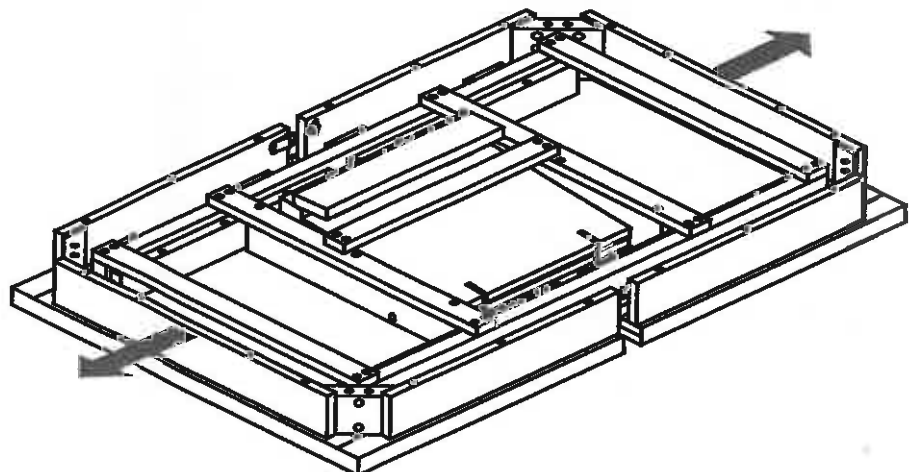

Assembly Instructions

Step 2

a: Now attach the legs **2** (x4) to each of the corners, by first step insert spring washers **B** and washers **C** into all the bolts **A**. Then screw the bolts **A** through the corner blocks and into the holes in the legs **2**. Tighten bolts by using the allen key **D**.

Tighten all 3 bolts securely.

b: 2 people are required for this next stage.

Please turn the table upright and place on your desired location.

Assembly is complete.

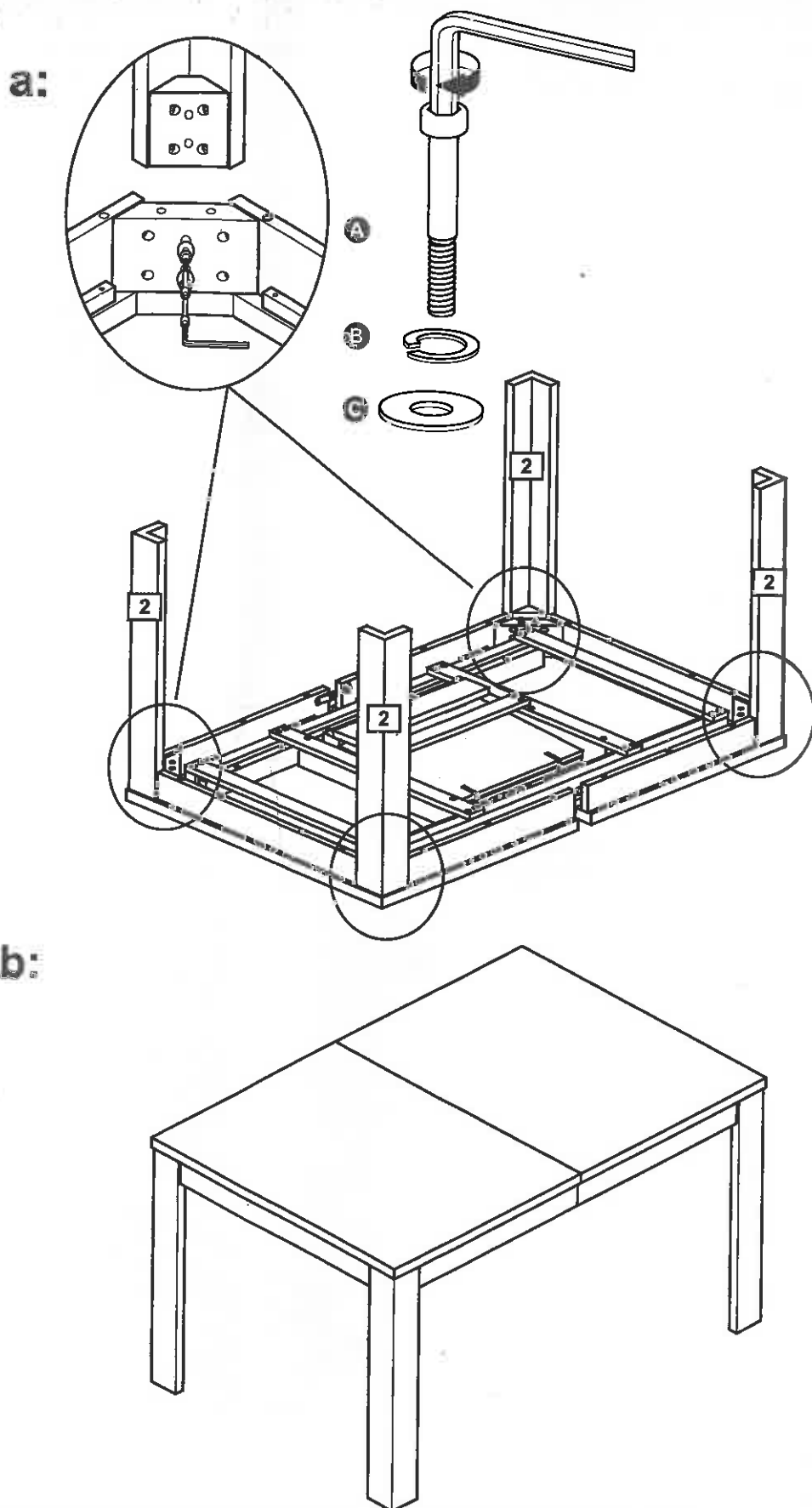

If you need help or have damaged or missing parts, call the **Customer Helpline: 0345 640 0800**

Assembly Instructions

Open Table

a: Release safety locks (see safety lock instruction below) Hold the apron of table to lift the table up and pull the table tops out as shown by the arrows.

a:

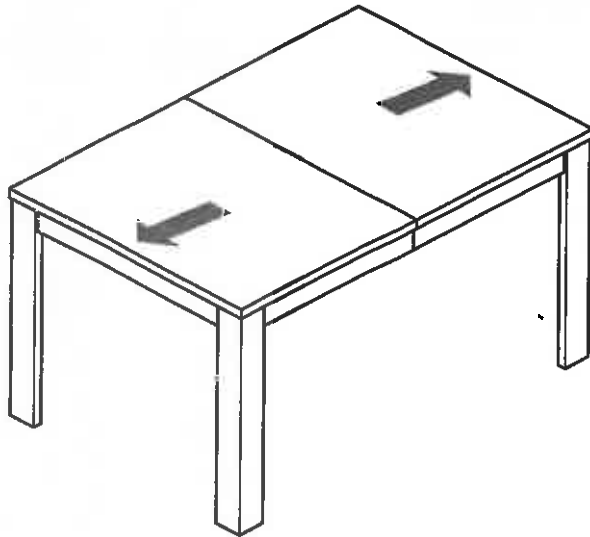

b: Make sure left and right side top and extension leaves are flat and aligned.

b:

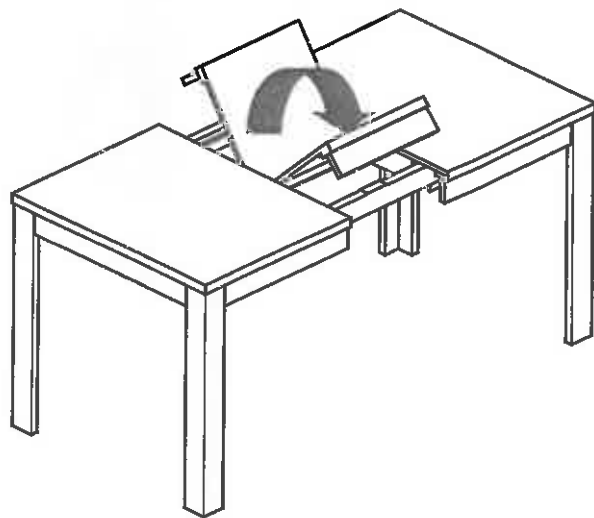

c: Hold the apron of table to push on both sides of tables as shown by the arrows. Use safety locks to ensure table tops will not move while using. (see safety lock instruction below)

c:

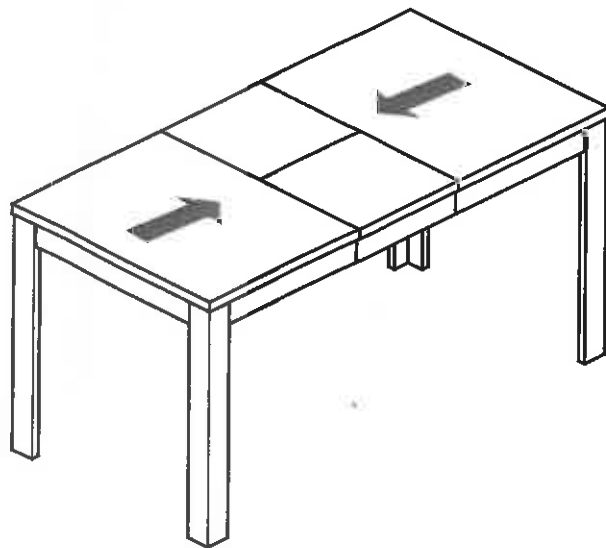

SAFETY LOCK INSTRUCTION.

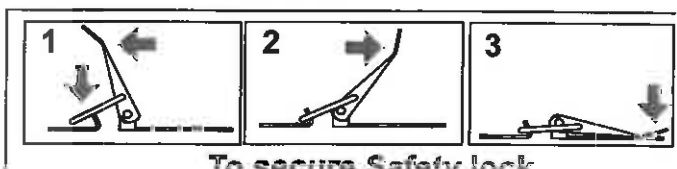
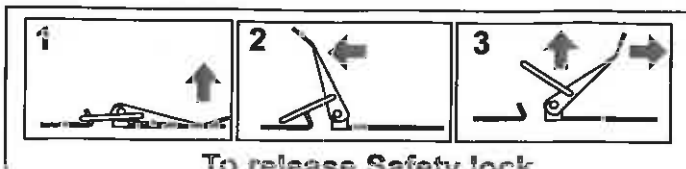

Assembly Instructions

Close Table

a: Release safety locks (see safety lock instruction below) Hold the apron of table to lift the table up and pull the table tops out as shown by the arrows.

a:

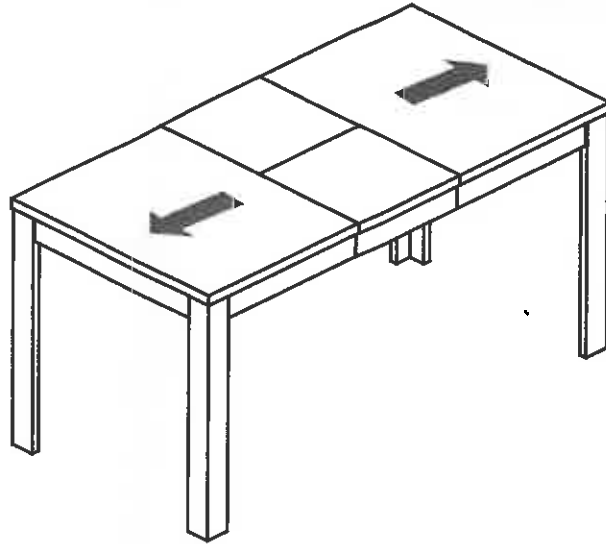

b: Close the extension leaves.

b:

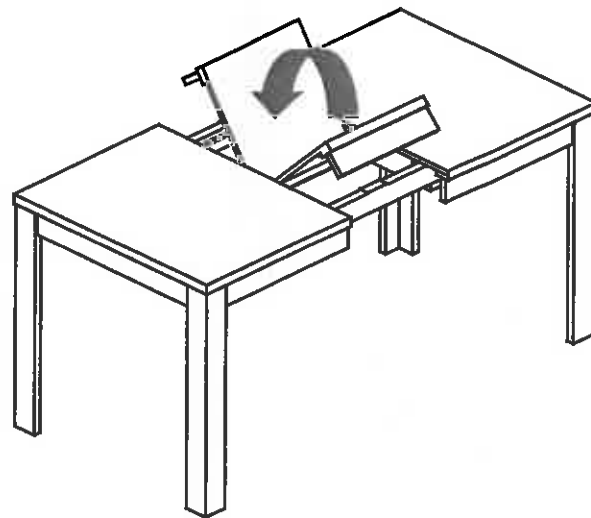

c: Hold the apron of table to push on both sides of tables as shown by the arrows. Use safety locks to ensure table tops will not move while using. (see safety lock instruction below)

c:

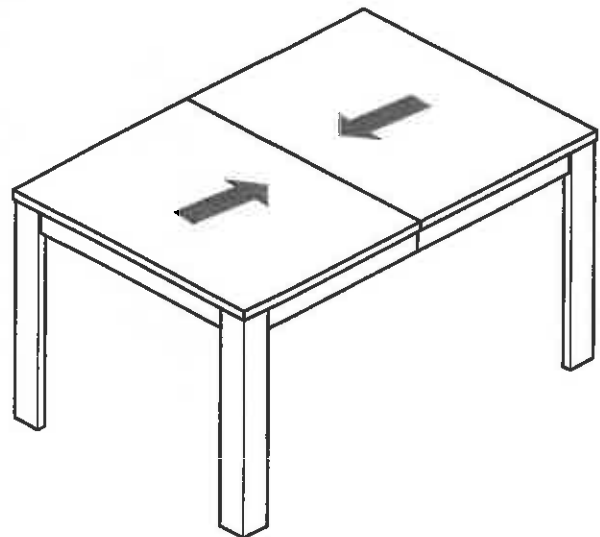

SAFETY LOCK INSTRUCTION.

7



To release Safety lock

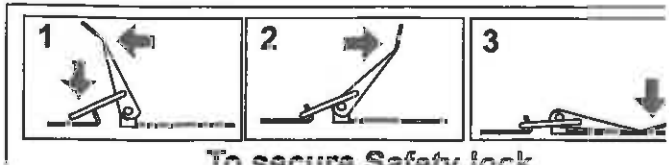

To secure Safety lock