

Montana - Corner TV Unit

Assembly Instructions - Please keep for future reference

395/6883

391/7657

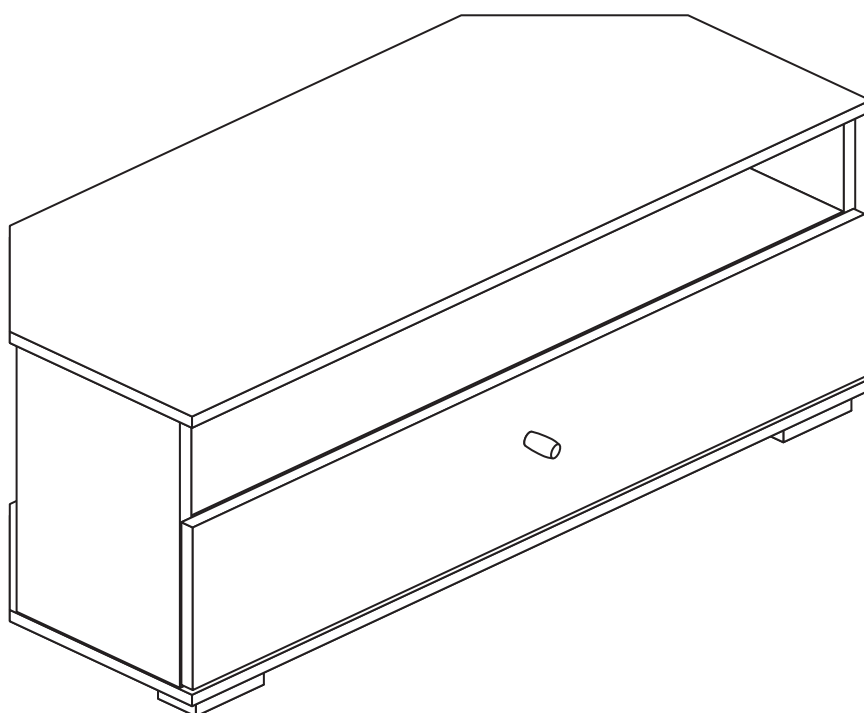

Dimensions

Width - 90cm

Depth - 39.5cm

Height - 41cm



**MADE IN
BRITAIN**

Important - Please read these instructions fully before starting assembly

If you need help or have damaged or missing parts, call the **Customer Helpline: 03456 400800**



Safety and Care Advice

Important - Please read these instructions fully before starting assembly

- **Warning:** This unit weighs approximately 17kgs. Please lift with care.

- Check you have all the components and tools listed on pages 2 and 3.

- Remove all fittings from the plastic bags and separate them into their groups.

- Keep children and animals away from the work area, small parts could choke if swallowed.

- Parts of the assembly will be easier with 2 people.

- Make sure you have enough space to layout the parts before starting.

- Do not stand or put weight on the product, this could cause damage.

- Assemble the item as close to its final position (in the same room) as possible.

- Assemble on a soft level surface to avoid damaging the unit or your floor (use opened out unit carton).



- We do not recommend the use of power drill/drivers **for inserting screws**, as this could damage the unit. Only use hand screwdrivers.

- **Safety note:** If there is any chance of this unit being pulled over by children etc. it is recommended that the unit is secured to a wall using suitable fixings (not supplied).

- Dispose of all packaging carefully and responsibly.

Care and maintenance

- Only clean using a damp cloth and mild detergent, do not use bleach or abrasive cleaners.

- From time to time check that there are no loose screws on this unit.

- This product should not be discarded with household waste. Take to your local authority waste disposal centre.

Note: If required the next page can be cut out and used as reference throughout the assembly. Keep this page with these instructions for future reference.

Components - Panels

If you have damaged or missing components, call the
Customer Helpline: 03456 400800 quoting the reference
numbers below

Please check you have all the panels listed below

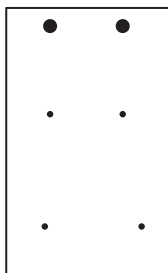

1 Left End (DF3541)
(353 x 216mm)

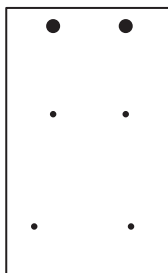

2 Right End (DF3542)
(353 x 216mm)

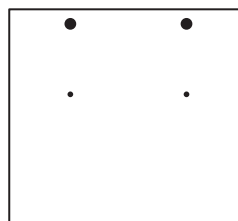

3 Back (DF3543)
(353 x 394mm)

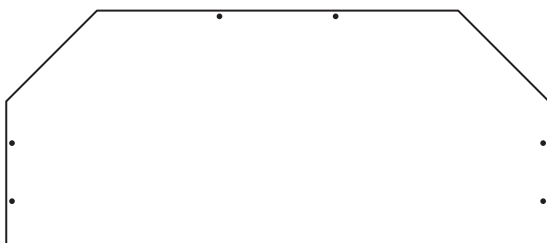

4 Top (DF3539)
(897 x 391mm)

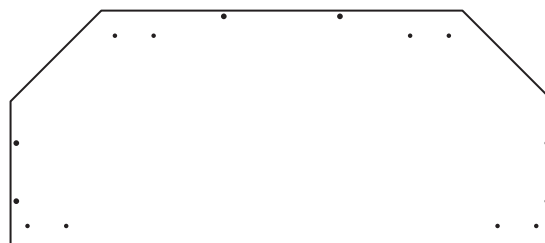

5 Base (DF3540)
(897 x 391mm)

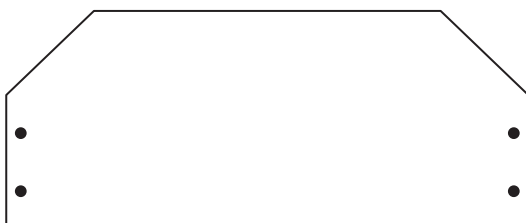

6 Horizontal (DF3544)
(863 x 355mm)

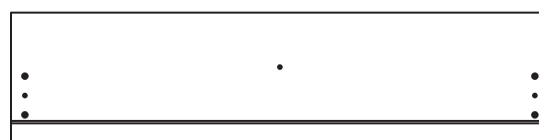

7 Drawer Front (DF3545)
(889 x 215mm)



8 Left Drawer Side (W210-124LH)
(210 x 124mm)



10 Drawer Back (W830-124)
(830 x 124mm)



9 Right Drawer Side (W210-124RH)
(210 x 124mm)



11 Drawer Base (T841-207)
(841 X 207mm)











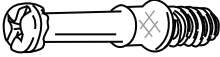

Components - Fittings

If you have damaged or missing components, call the **Customer Helpline: 03456 400800** quoting the reference numbers below

Please check you have all the fittings listed below

Note: The quantities below are the correct amount to complete the assembly. In some cases more fittings may be supplied than are required.

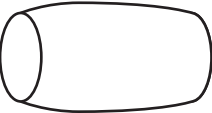
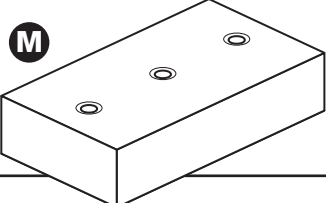
<p>A </p> <p>Metal dowel (F901) x 12</p>	<p>B </p> <p>Large locking nut (F900) x 10</p>	<p>C </p> <p>Small locking nut (F3) x 2</p>
<p>D </p> <p>Knock-in Peg (F171GY) x 4</p>	<p>E </p> <p>40mm Screw (F910) x 8</p>	<p>F </p> <p>38mm Screw (F81) x 8</p>
<p>G </p> <p>19mm Screw (F461) x 1</p>	<p>H </p> <p>9mm Screw (F73) x 4</p>	<p>I </p> <p>9mm Screw (F74) x 2</p>
<p>J </p> <p>Drawer runner (F307) x 2</p>		<p>K </p> <p>Wedgefix (F639) x 4</p>
<p>L </p> <p>Handle (F341) x 1</p>	<p>M </p> <p>Foot (F233) x 4</p>	

Tools required

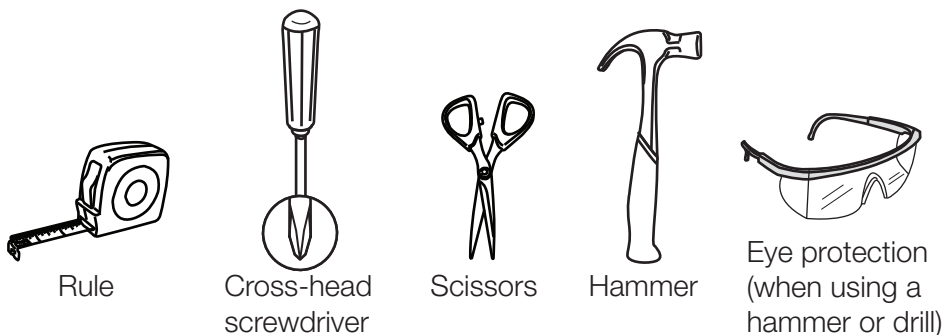

Ruler - Use this ruler to help correctly identify the screws



Assembly Instructions

If you have damaged or missing components, call the
Customer Helpline: 03456 400800 quoting the reference
numbers below

Step 1

Prepare the drawer front

Screw 2 metal dowels **A** into the drawer front **7**.

Note: Tighten the metal dowels up fully against the panels.

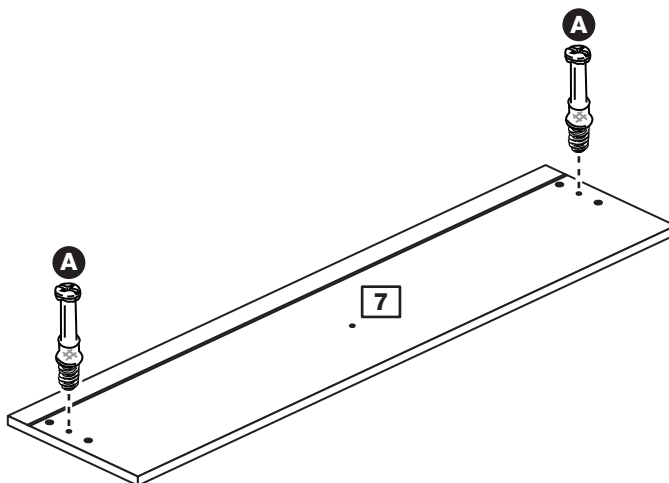
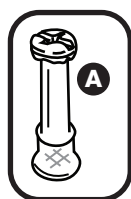

Step 2

Prepare the drawer sides

Insert a small locking nut **C** into the hole shown on the left drawer side **8** and the right drawer side **9**.

Note: The arrow on the locking nut **must** point towards the hole in the edge of the panel.

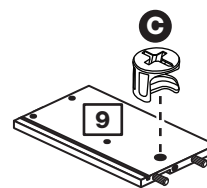
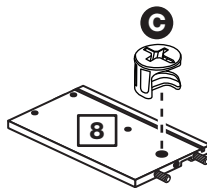
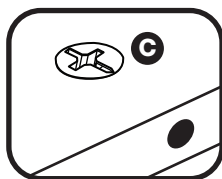

Step 3

Attach the drawer sides to the drawer front

Push the left drawer side **8** and right drawer side **9** onto the back of the drawer front **7**.

Turn the small locking nuts **C** on the left drawer side **8** and right drawer side **9**.

Note: Turn the locking nuts **C** clockwise to secure panels - more than 1/2 a turn.

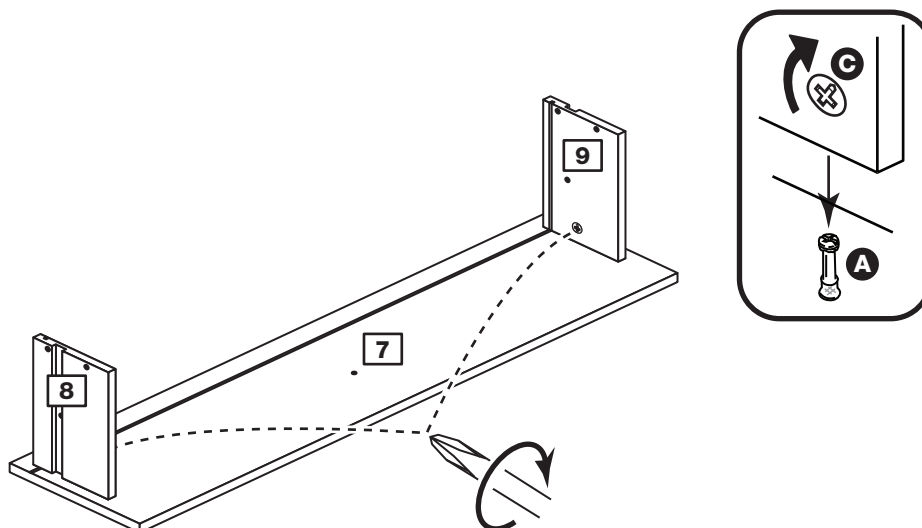

Assembly Instructions

Step 4

Fit the drawer base

Slide the drawer base **11** down the grooves in the drawer sides **8** and **9** and down into the groove in the drawer front **7**.

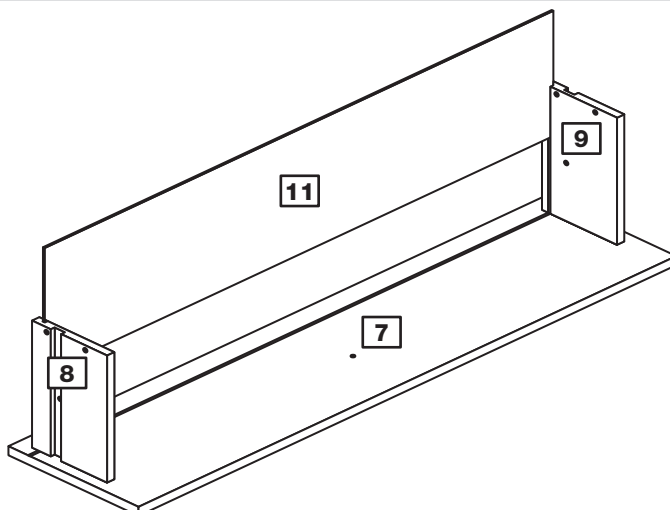

Step 5

Fit the drawer back

Fit the drawer back **10** between the drawer sides **8** and **9**. Make sure that the drawer base **11** fits into the groove in the drawer back **10**.

Hold the drawer back **10** in position and tap the knock-in pegs **D** through the holes in the drawer sides **8** and **9**.

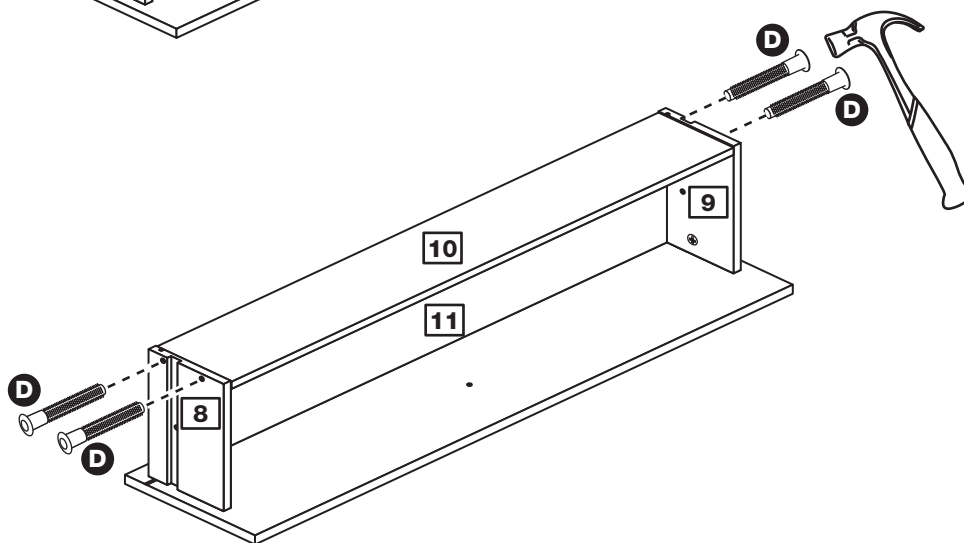

Step 6

Attach the handle

Attach a handle **L** to the drawer front **7** using screw **G**.

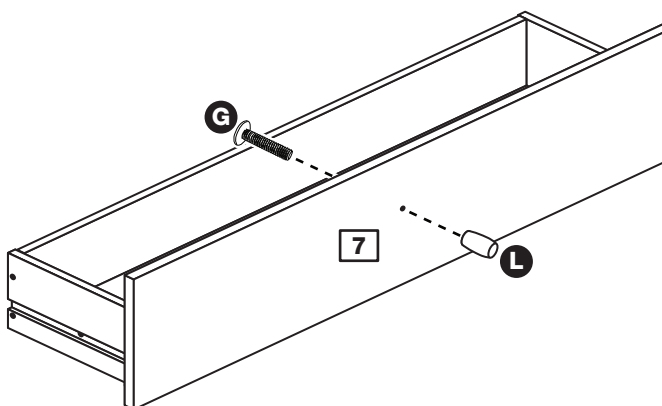

Step 7

Fit the wedgifixes

Turn the drawer assembly over and slide 4 wedgifixes **K** into the front and back grooves, as shown, and tighten up the screws.

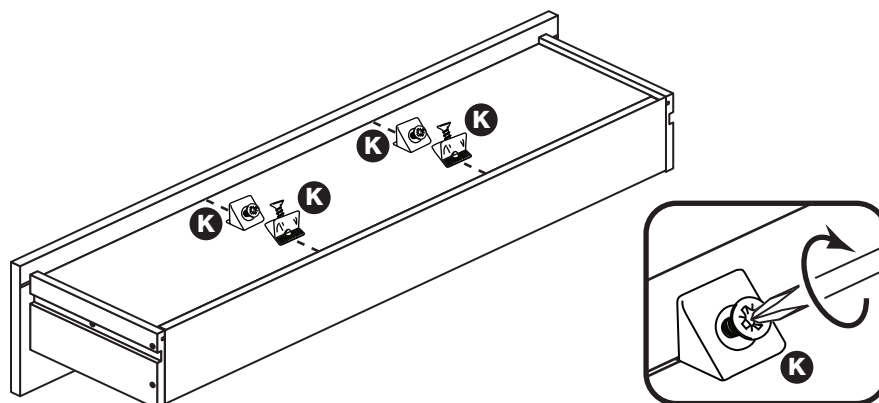

Assembly Instructions

Step 8

Prepare the left side

a: Place a runner **J** onto the left side **1**. Slide back the top of runner and use the 2nd hole from the front to fit the 1st screw **H**.

b: Slide the runner **J** back the other way and fit the 2nd screw **H** into the corresponding hole in the left side **1**.

c: Screw 2 metal dowels **A** into the left side **1**.

Insert 2 large locking nuts **B** into the left side **1**.

Note: The arrow on the locking nuts **must** point towards the hole in the edge of the panel.

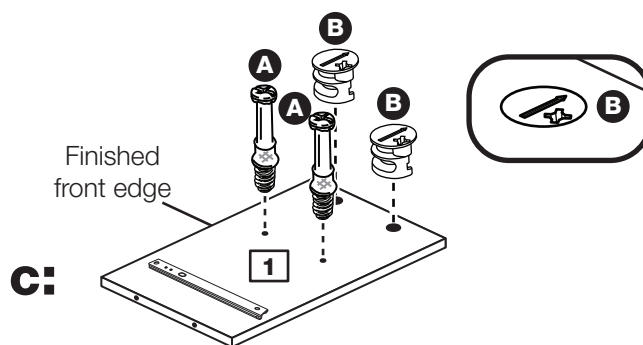
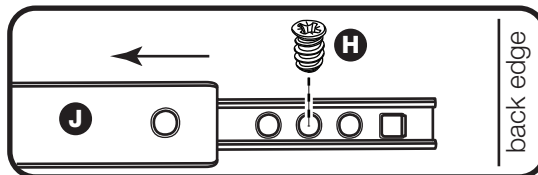
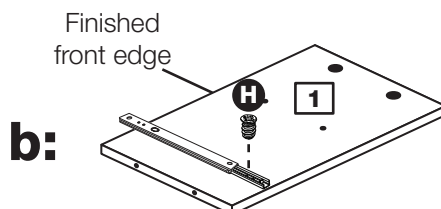
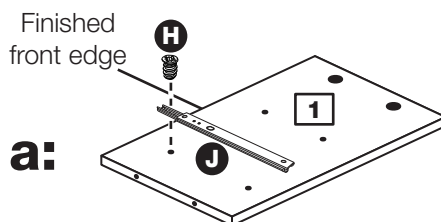
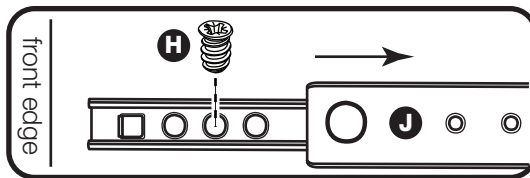

Assembly Instructions

Step 9

Prepare the right side

a: Place a runner **J** onto the right side **2**. Slide back the top of runner and use the 2nd hole from the front to fit the 1st screw **H**.

b: Slide the runner **J** back the other way and fit the 2nd screw **H** into the corresponding hole in the right side **2**.

c: Screw 2 metal dowels **A** into the right side **2**.

Insert 2 large locking nuts **B** into the right side **2**.

Note: The arrow on the locking nuts **must** point towards the hole in the edge of the panel.

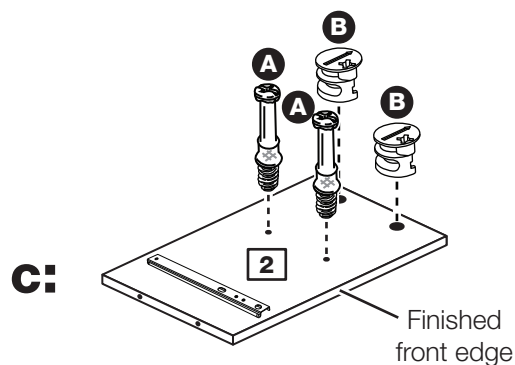
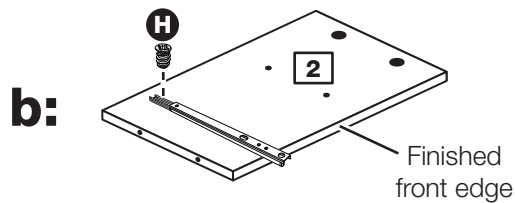
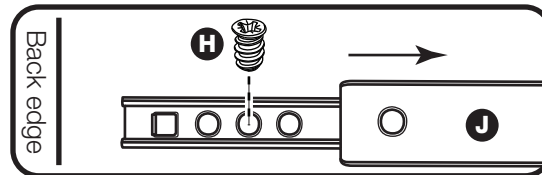
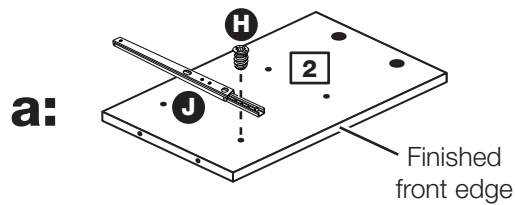
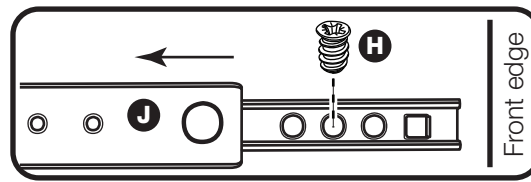

Assembly Instructions

Step 10

Prepare the top

Screw 6 metal dowels **A** into the top **4**.

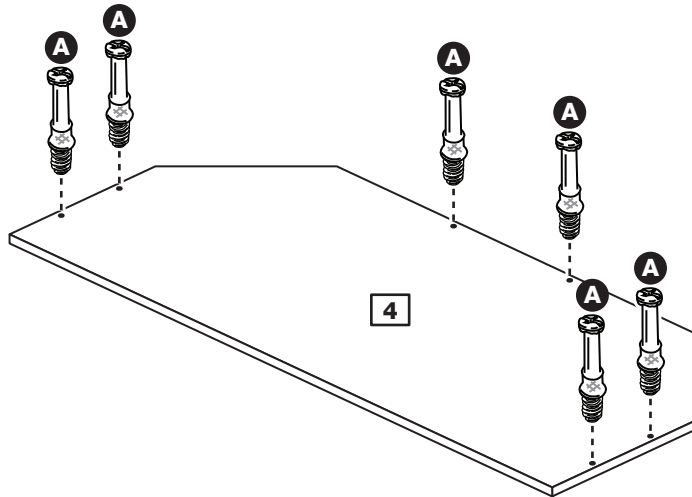

Step 11

Fit the right side to the top

Push the right side **2** onto the top **4**.

Use a screwdriver to tighten the 2 large locking nuts **B** fitted to the right side **2**.

Note: Turn the large locking nuts **B** as far as they will go - more than 1/2 a turn.

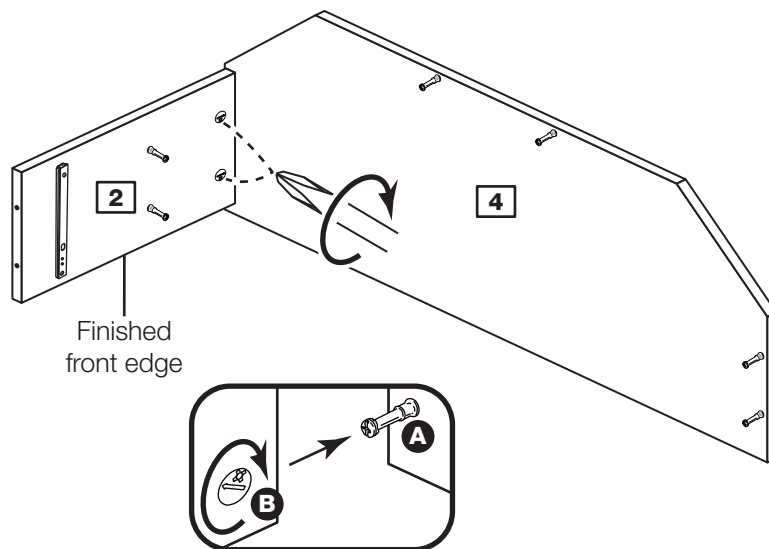

Step 12

Prepare the horizontal

Insert 4 large locking nuts **B** into the horizontal **6**.

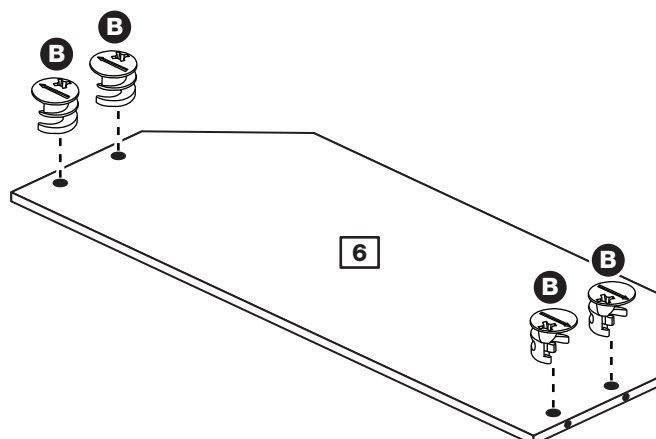

Assembly Instructions

Step 13

Fit the horizontal

Push the horizontal **6** onto the right side **2**.

Use a screwdriver to tighten the 2 large locking nuts **B** fitted to the horizontal **6**.

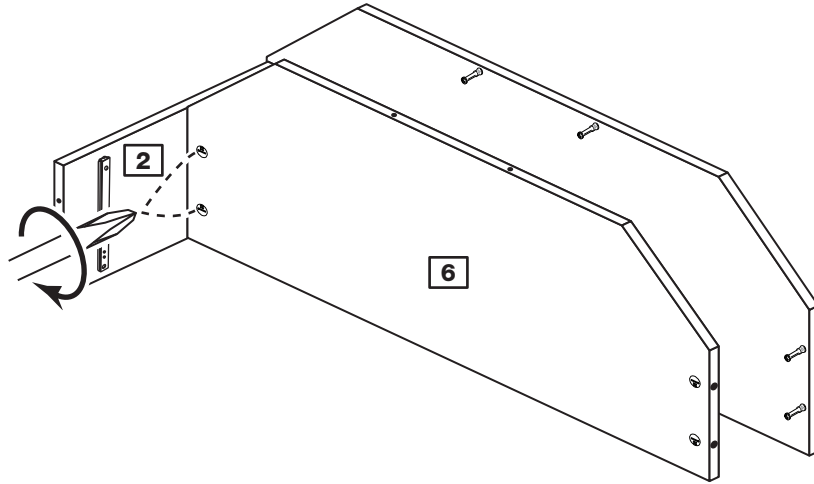

Step 14

Fit the left side to the top and horizontal

Push the left side **1** onto the top **4** and horizontal **6**.

Use a screwdriver to tighten the 4 large locking nuts **B** fitted to the top **4** and the horizontal **6**.

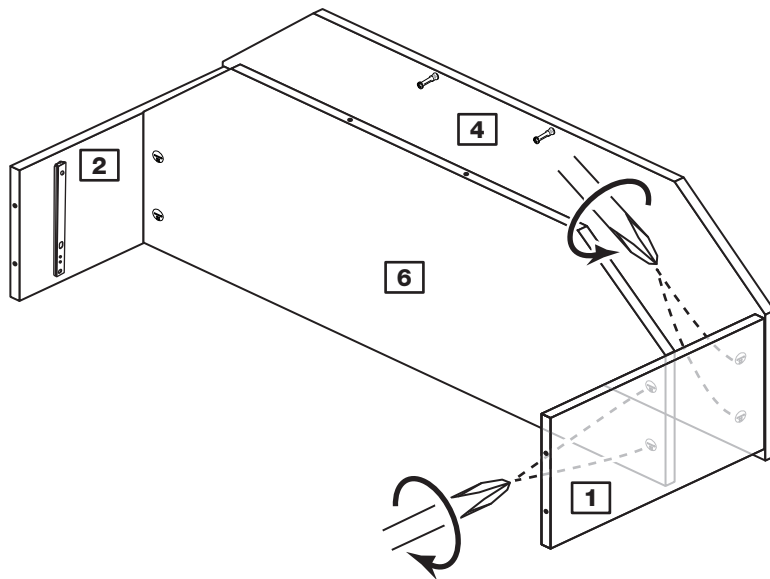

Step 15

Prepare the back

Insert 2 large locking nuts **B** into the back **3**.

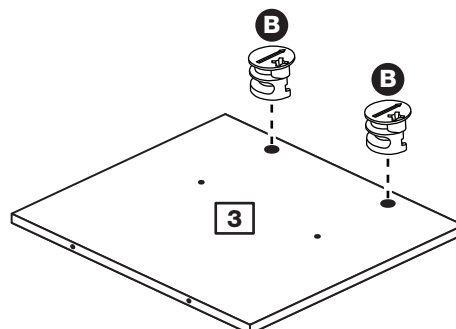

Assembly Instructions

Step 16

Fit the back

Push the back **3** onto the top **4**.

Use a screwdriver to tighten the 2 large locking nuts **B** fitted to the back **3**.

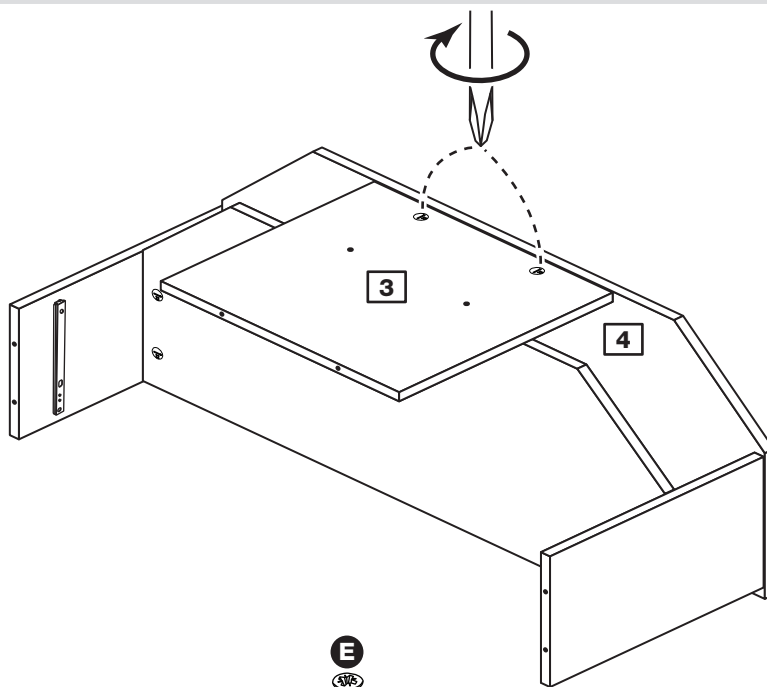

Step 17

Secure the back

Fix the back **3** to the horizontal **6** using 2 screws **E**.

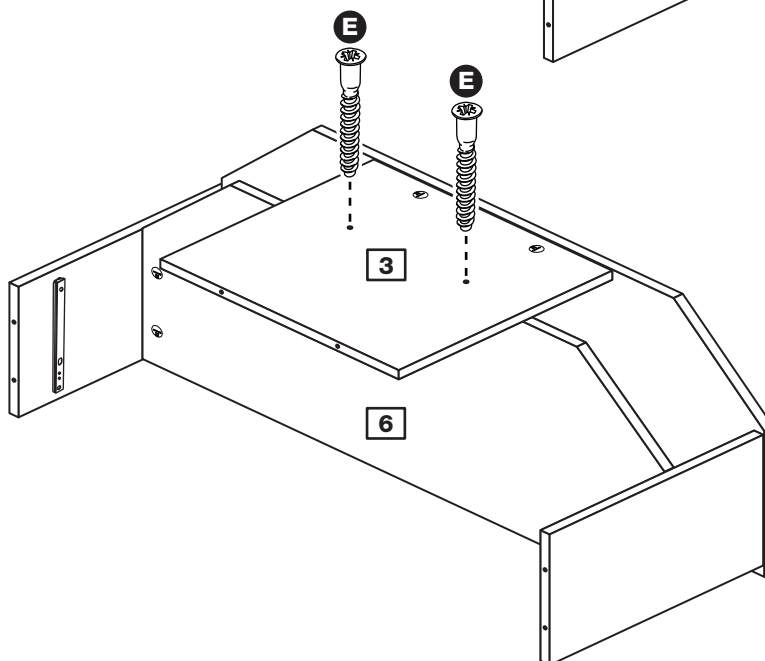

Step 18

Fit the base

Fit the base **5** onto the assembly using 6 screws **E**.

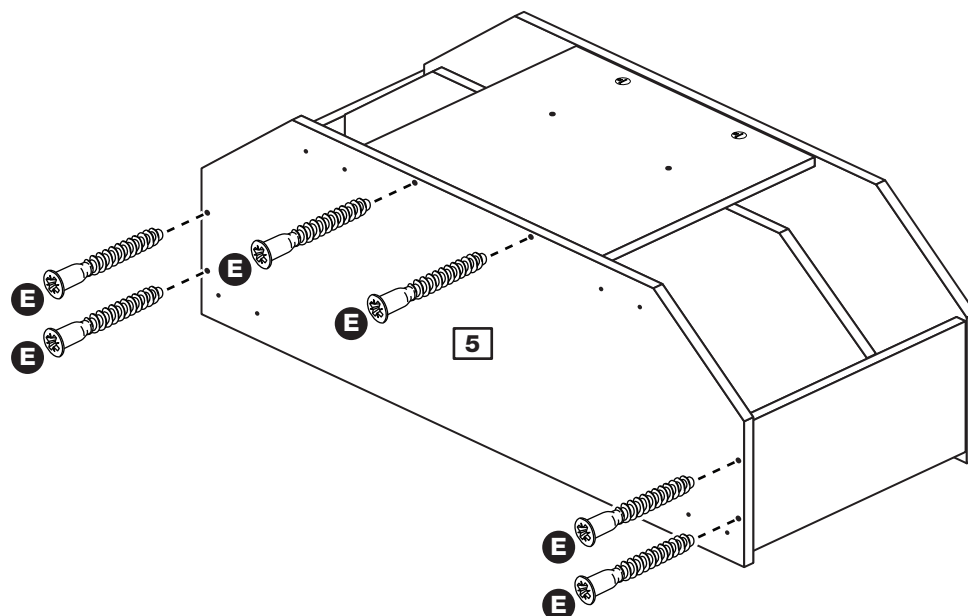

Assembly Instructions

Step 19

Fit the feet

Fit the feet **M** to the base **5** using screws **F**.

Carefully stand the unit up for the next step.



Warning: The unit is heavy. Lift with care.

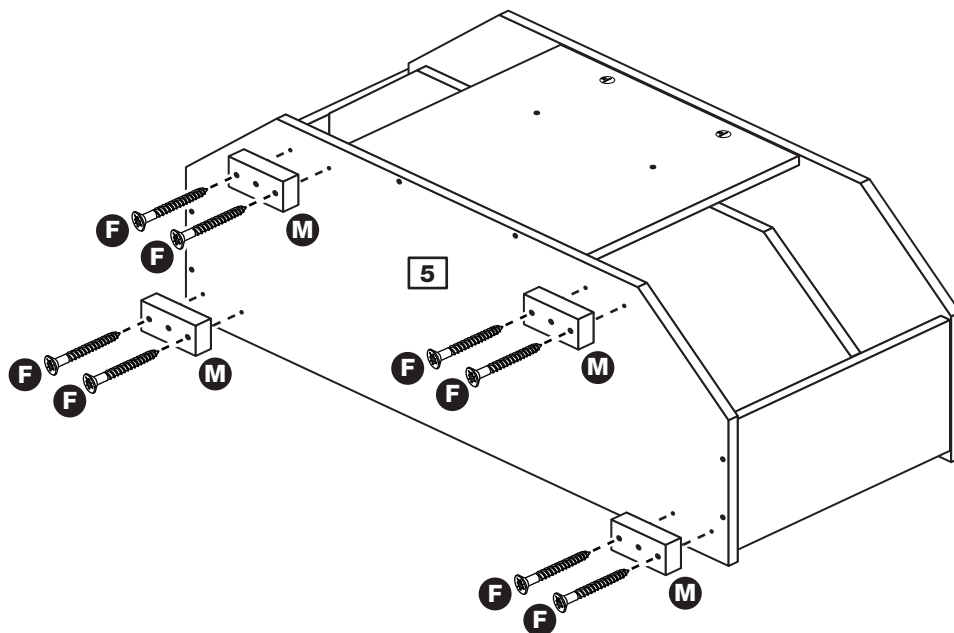

Step 20

Fit the drawer

Slide both the runners **J** forward and locate the drawer sides **8** and **9** between them, lining up the holes in the drawer wrap with the 2nd 'threaded' holes in the runners **J**.

Working from the inside of the drawer, insert 2 screws **I** through the drawer sides and out into the 2nd threaded hole in the runner.

Note: Do not overtighten the screws **I**. If they catch on the runner you may need to loosen them slightly.

Assembly is complete

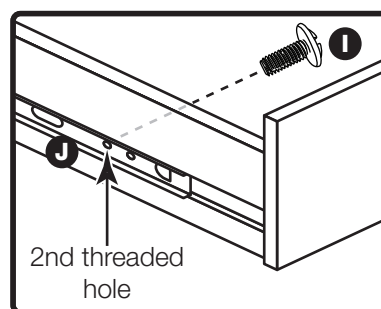
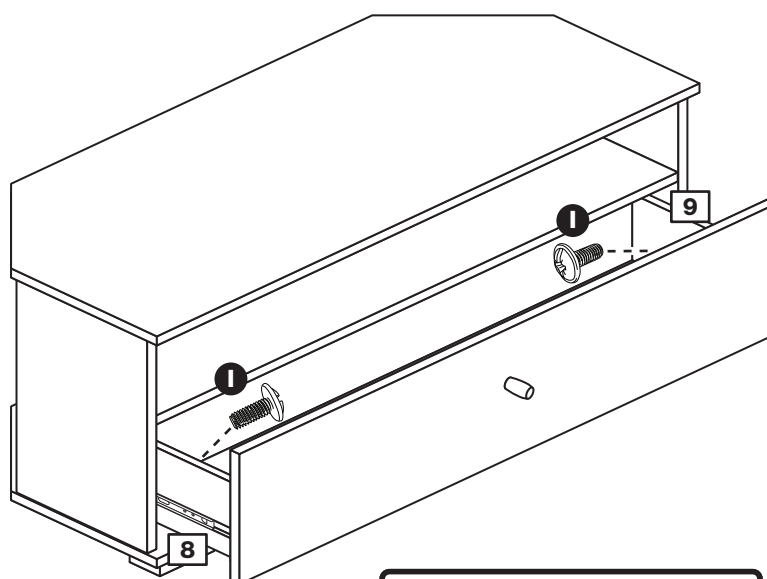

If you need help or have damaged or missing parts, call the Customer Helpline: 03456 400800 and quote the reference numbers on the component pages.

Argos Ltd, 489-499 Avebury Boulevard, Central Milton Keynes, MK9 2NW