

1 Drawer 2 Door Robe

Assembly Instructions - Please keep for future reference

246/6848

247/3329

248/4150

331/5974

357/7310

355/7354

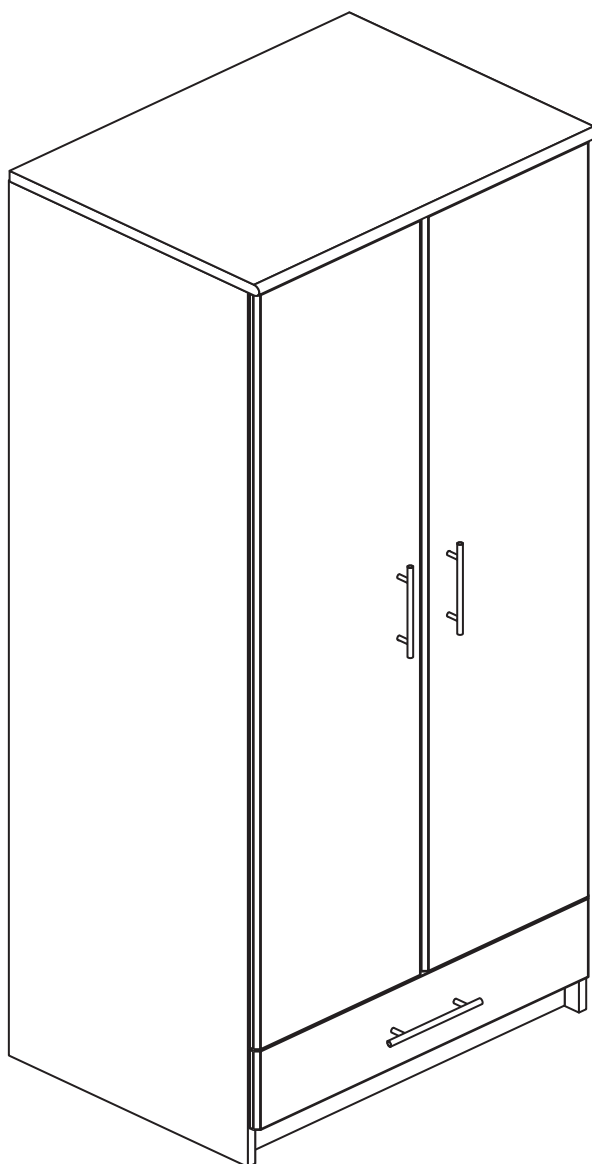

Dimensions

Width - 70.5cm

Depth - 52cm

Height - 183cm



**MADE IN
BRITAIN**

Important - Please read these instructions fully before starting assembly

If you need help or have damaged or missing parts, call the **Customer Helpline: 08456 400800**



Safety and Care Advice

Important - Please read these instructions fully before starting assembly

- **Warning:** This unit weighs approximately 48kgs. Please lift with care.
- Check you have all the components and tools listed on pages 1, 2 and 3.
- Remove all fittings from the plastic bags and separate them into their groups.
- Keep children and animals away from the work area, small parts could choke if swallowed.
- Parts of the assembly will be easier with 2 people.

- Make sure you have enough space to layout the parts before starting.
- Do not stand or put weight on the product, this could cause damage.
- Assemble the item as close to its final position (in the same room) as possible.
- Assemble on a soft level surface to avoid damaging the unit or your floor (use opened out unit carton).



• We do not recommend the use of power drill/drivers **for inserting screws**, as this could damage the unit. Only use hand screwdrivers.

• **Safety note:** It is recommended that this unit is secured to a wall using the bracket supplied.

• Dispose of all packaging carefully and responsibly.

Care and maintenance

- Only clean using a damp cloth and mild detergent, do not use bleach or abrasive cleaners.
- From time to time check that there are no loose screws on this unit.
- This product should not be discarded with household waste. Take to your local authority waste disposal centre.

Tools required



Rule

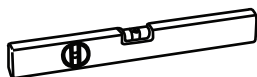

Spirit level



Eye protection (when using a hammer or drill)

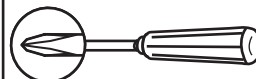

Cross-head screwdriver

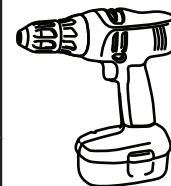

Electric drill (only use when drilling into walls)

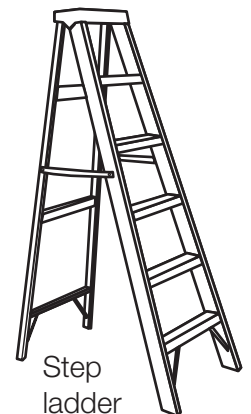

Step ladder

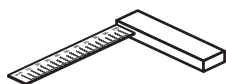

Square



Scissors



Hammer

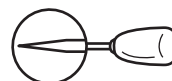

Bradawl

Note: If required the next page can be cut out and used as reference throughout the assembly. Keep this page with these instructions for future reference.

Components - Panels

If you have damaged or missing components, call the **Customer Helpline: 08456 400800** quoting the reference numbers below

Please check you have all the panels listed below

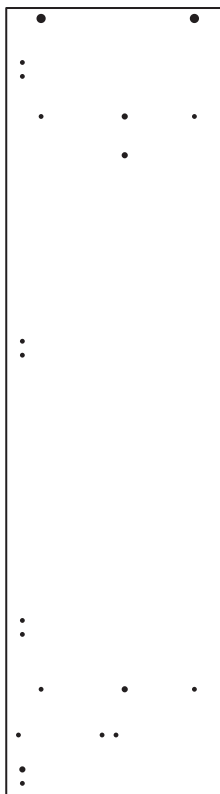

1 Left Side (D2356A)
(1808 x 494mm)

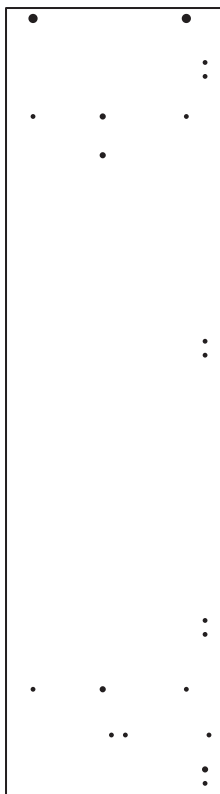

2 Right Side (D2357A)
(1808 x 494mm)



3 Top (D2355A)
(702 x 516mm)



4 Base (D2358A)
(669 x 493mm)

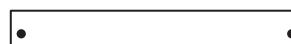

5 Plinth (D2360A)
(669 x 80mm)



6 Horizontal (D2359A)
(669 x 493mm)

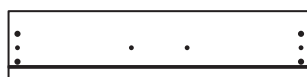

7 Drawer Front (D2362A)
(692 x 162mm)

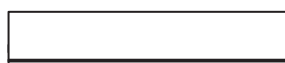

8 Drawer Back (W639-124)
(639 x 124mm)



9 Left Drawer Side (W370-124LH)
(370 x 124mm)



11 Drawer Base (T650-367)
(650 x 367mm)



10 Right Drawer Side (W370-124RH)
(370 x 124mm)



12 Hanging Rail (FHR660)
(660mm long)

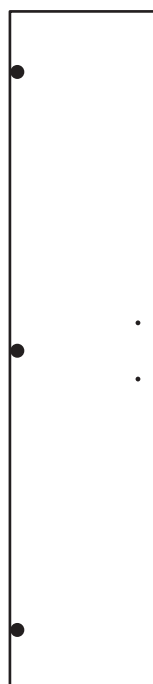

13 Door (D2361A)
(1559 x 345mm) x 2

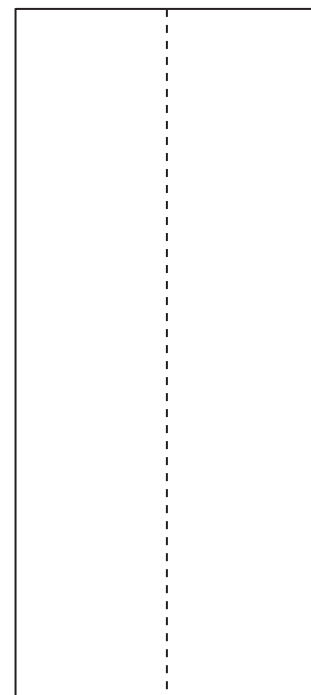

14 Back (X1590-695)
(1590 x 695mm)











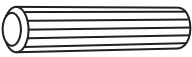
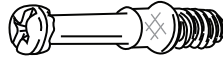





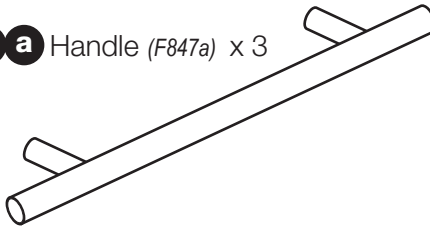

Components - Fittings

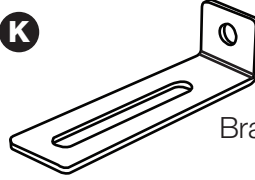
If you have damaged or missing components, call the
Customer Helpline: 08456 400800 quoting the reference
 numbers below

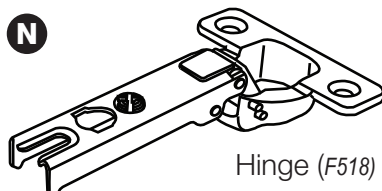
Please check you have all the fittings listed below

Note: The quantities below are the correct amount to complete the assembly. In some cases more fittings may be supplied than are required.

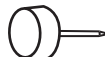
<p>A </p> <p>Wooden dowel (F22) x 8</p>	<p>B </p> <p>Metal dowel (F901) x 16</p>	<p>C </p> <p>Large locking nut (F900) x 14</p>
<p>D </p> <p>Small locking nut (F3) x 2</p>	<p>E </p> <p>13mm Screw (F79) x 1</p>	<p>F </p> <p>13mm Screw (F63) x 14</p>
<p>G </p> <p>9mm Screw (F74) x 2</p>	<p>H </p> <p>9mm Screw (F73) x 4</p>	<p>I </p> <p>Knock-in Peg (F171) x 4</p>
<p>J a  Handle (F847a) x 3</p> <p>J b  Handle Screw (F847b) x 6</p>		<p>K  Bracket (F327) x 1</p>
<p>L  Rail holder (F1014) x 2</p>	<p>M  Hinge plate (F523) x 6</p>	<p>N  Hinge (F518) x 6</p>
<p>O  Drawer runner (F1004) x 2</p>		<p>P  Nail (F51) x 33</p>
<p>Q  Wedgifix (F639) x 4</p>	<p>R  Plastic Nail (F91) x 4</p>	

Ruler - Use this ruler to help correctly identify the screws

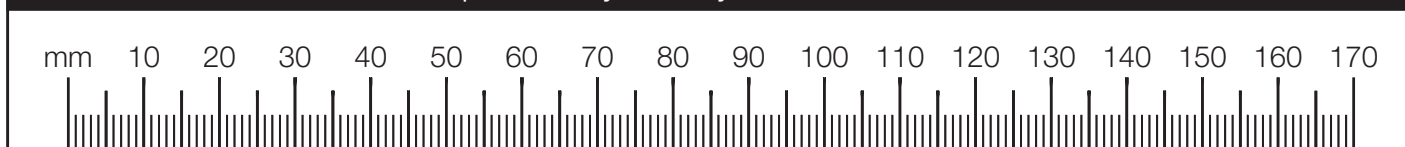

Assembly Instructions

If you have damaged or missing components, call the **Customer Helpline: 08456 400800** quoting the reference numbers below

Step 1

Prepare the drawer front

Screw 2 metal dowels **B** into the holes shown on the back of the drawer front **7**.

Note: Tighten metal dowels up fully against the panels.

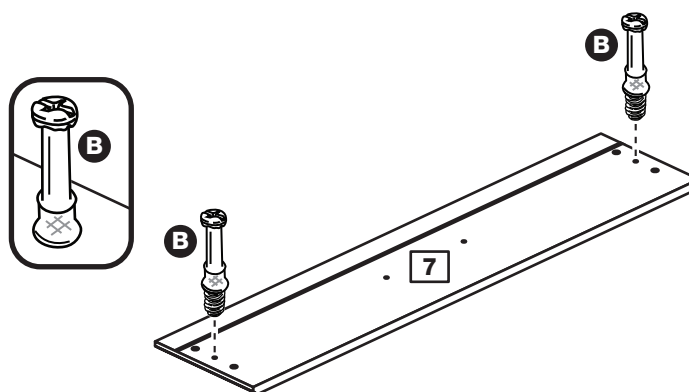

Step 2

Prepare the drawer sides

Insert a small locking nut **D** into the hole shown on the left drawer side **9** and right drawer side **10**.

Note: Arrow on locking nut **must** point towards hole in edge of panel.

Note: Due to the manufacturing process, the holes for the locking nut can be on either surface of the drawer sides.

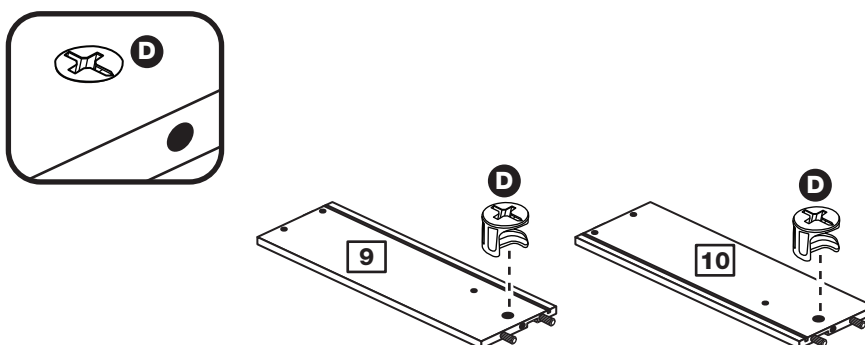

Step 3

Attach the drawer sides to the drawer front

Push the left drawer side **9** and right drawer side **10** onto the back of the drawer front **7**.

Turn the small locking nuts **D** on the left drawer side **9** and right drawer side **10**.

Note: Turn the locking nuts **D** clockwise to secure panels - more than 1/2 a turn.

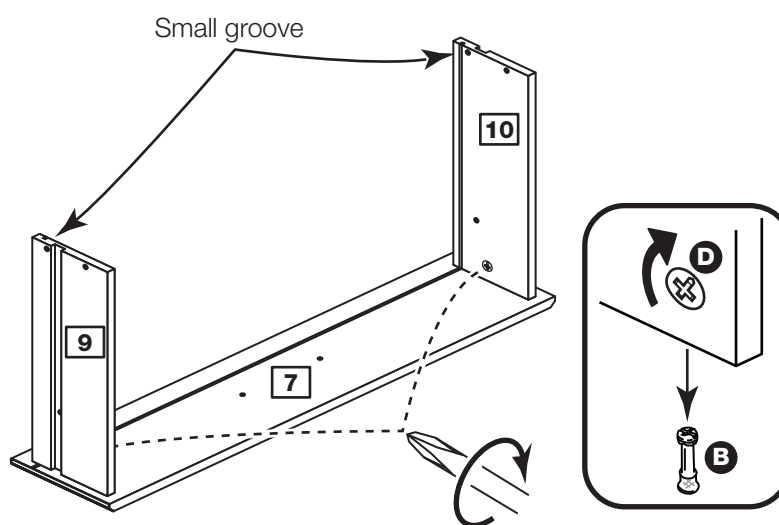

Note: The locking nuts can be on either surface of the drawer sides. Make sure that the small groove is on the inside, as shown.

Assembly Instructions

Step 4

Fit the drawer base

Slide the drawer base **11** down the grooves in the drawer sides **9** and **10** and then down into the groove in the drawer front **7**.

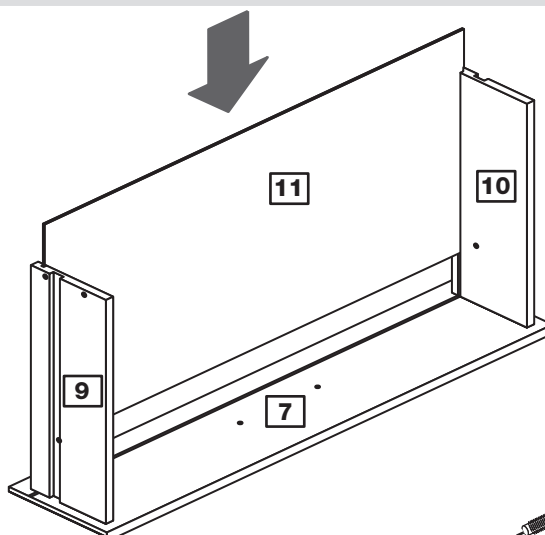

Step 5

Fit the drawer back

Fit the drawer back **8** between the drawer sides **9** and **10**.

Make sure that the drawer base **11** fits into the groove in the drawer back **8**.

Hold the drawer back **8** in position and tap the knock-in pegs **I** through the holes in the drawer sides **9** and **10**.

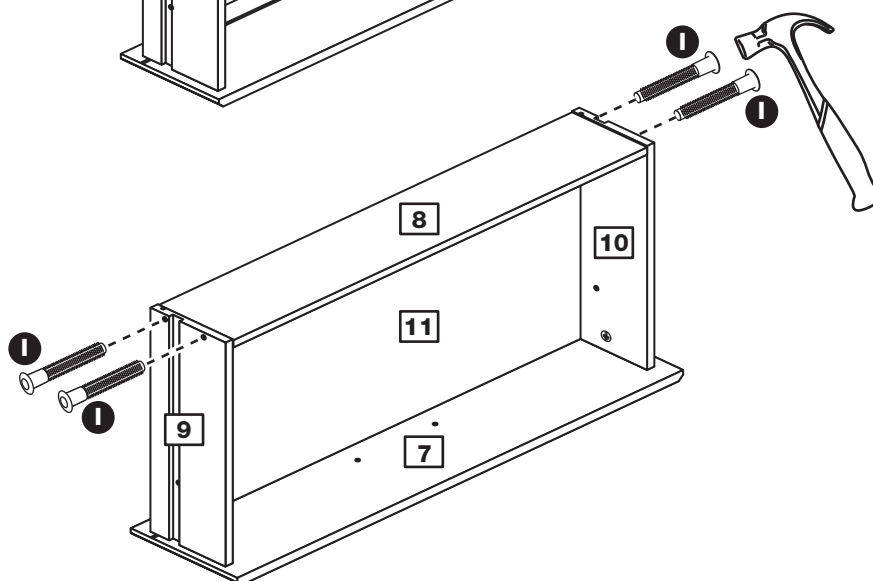

Step 6

Attach the handle

Attach the handle **J a** to the drawer front **7** using 2 screws **J b**.

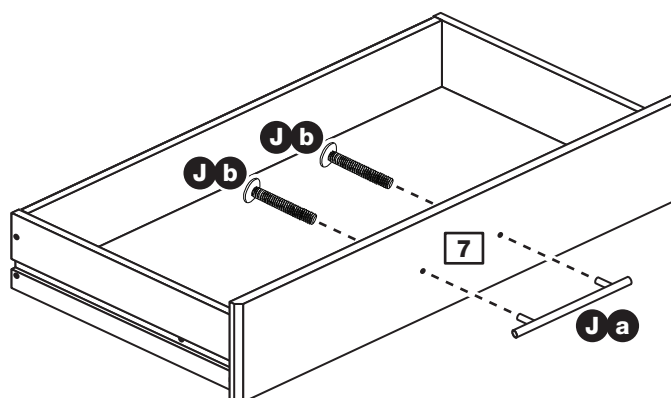

Step 7

Fit the wedgifixes

Turn the drawer assemblies over and slide 2 wedgifixes **Q** into the front and back grooves, as shown, and tighten up the screws.

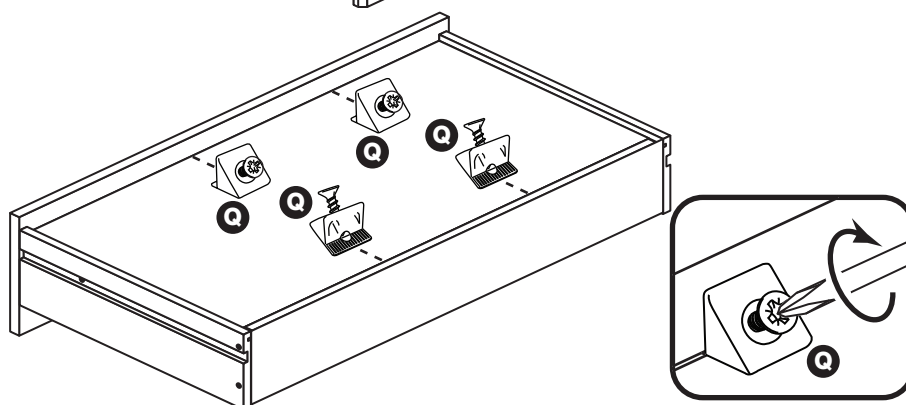

Assembly Instructions

Step 8

Prepare the left side

a: Place a runner **O** on the left side **1**. Slide back the top of runner and use the 2nd hole from the front to fit the 1st screw **H**.

b: Slide the runner back the other way and fit the 2nd screw **H** into the corresponding hole in the left side **1**.

Screw 5 metal dowels **B** into the left side **1**.

c: Tap a wooden dowel **A** into the left side **1**.

Note: Wooden dowels **must not** stick out from the edge by more than 10mm or they may damage other panels.

Insert 2 large locking nuts **C** into the left side **1**.

Note: The arrow on the locking nut **must** point towards the hole in the edge of the panel.

Push a rail holder **L** into the left side **1**. Make sure that it is fitted straight, in line with the panel edges and then secure with screw **F**.

Fit 3 hinge plates **M** onto the left side **1**, making sure that the slot is facing towards the finished front edge.

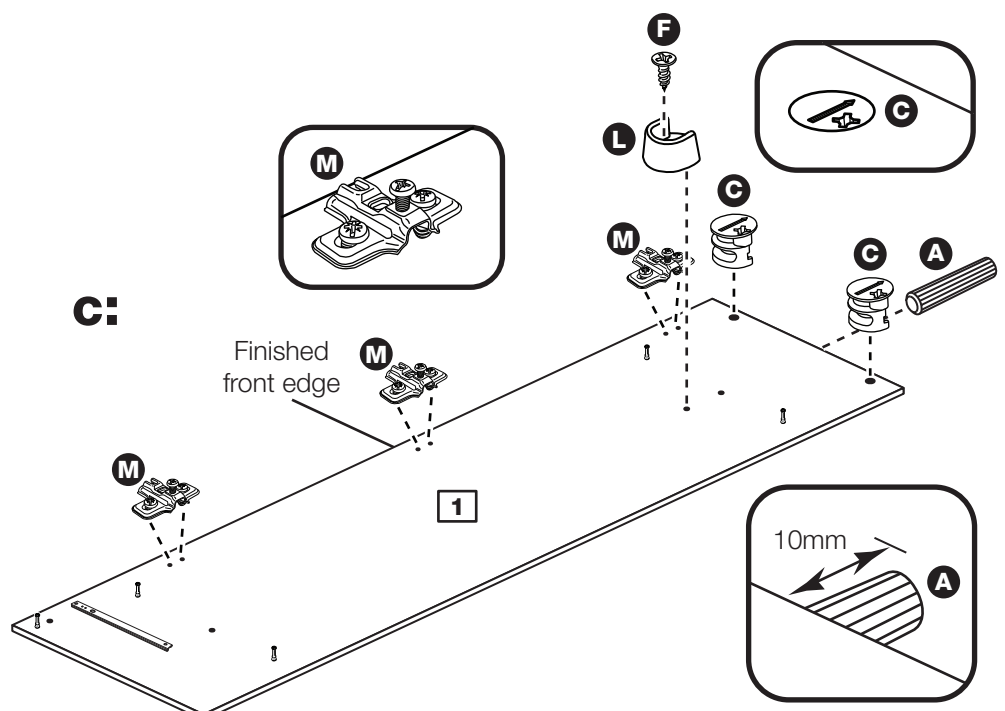
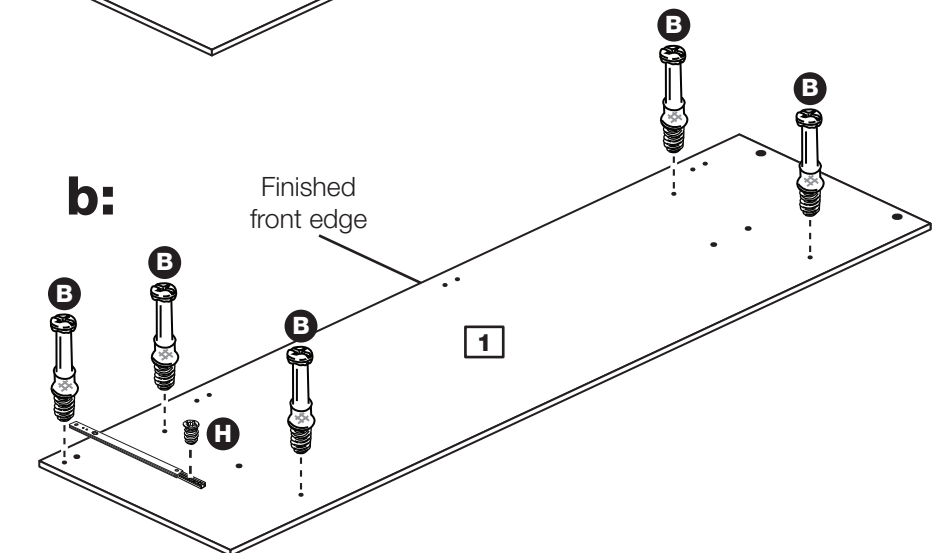
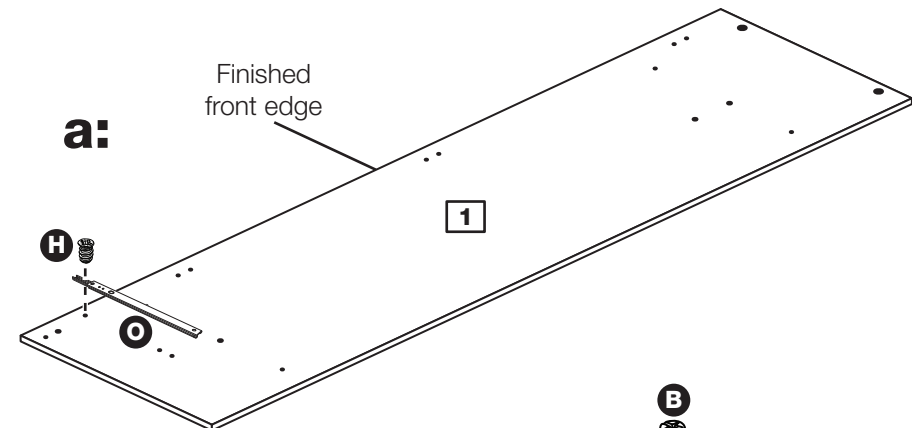
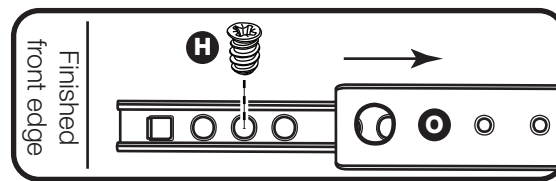

Assembly Instructions

Step 9

Prepare the right side

a: Place a runner **O** on the right side **2**. Slide back the top of runner and use the 2nd hole from the front to fit the 1st screw **H**.

b: Slide the runner back the other way and fit the 2nd screw **H** into the corresponding hole in the right side **2**.

Screw 5 metal dowels **B** into the right side **2**.

c: Tap a wooden dowel **A** into the right side **2**.

Insert 2 large locking nuts **C** into the right side **2**.

Push a rail holder **L** into the right side **2**. Make sure that it is fitted straight, in line with the panel edges and then secure with screw **F**.

Fit 3 hinge plates **M** onto the right side **2**, making sure that the slot is facing towards the finished front edge.

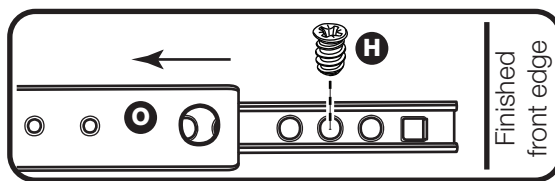

a:

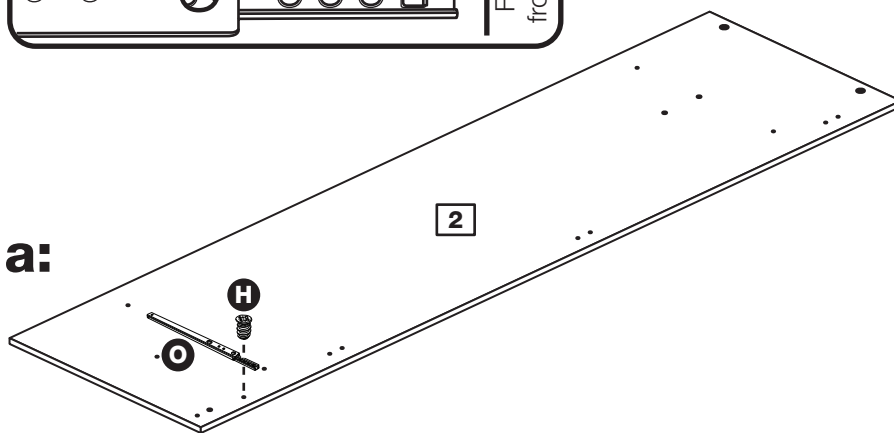

b:

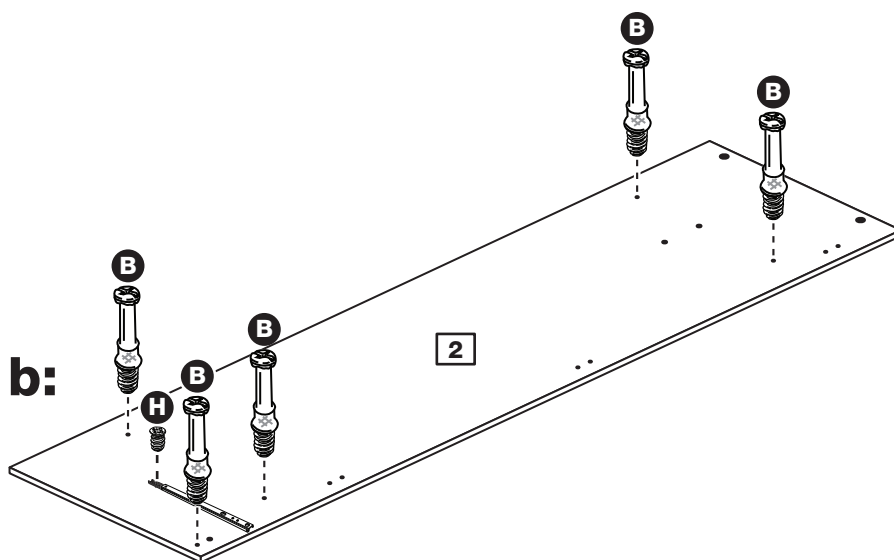

c:

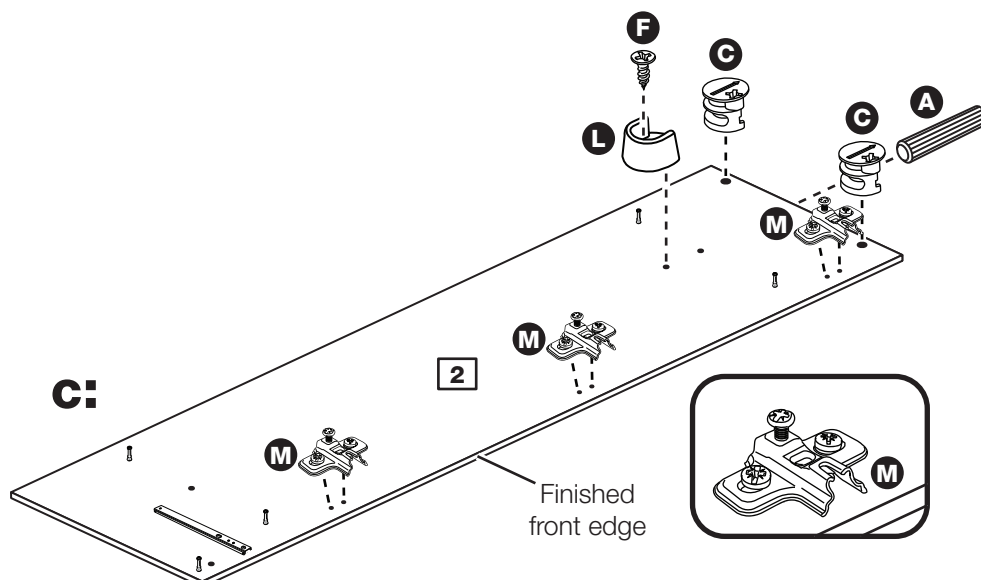

Assembly Instructions

Step 10

Prepare the base and horizontal

Tap 2 wooden dowels **A** into the base **4**.

Insert 4 large locking nuts **C** into the base **4**.

Tap 2 wooden dowels **A** into the horizontal **6**.

Insert 4 large locking nuts **C** into the horizontal **6**.

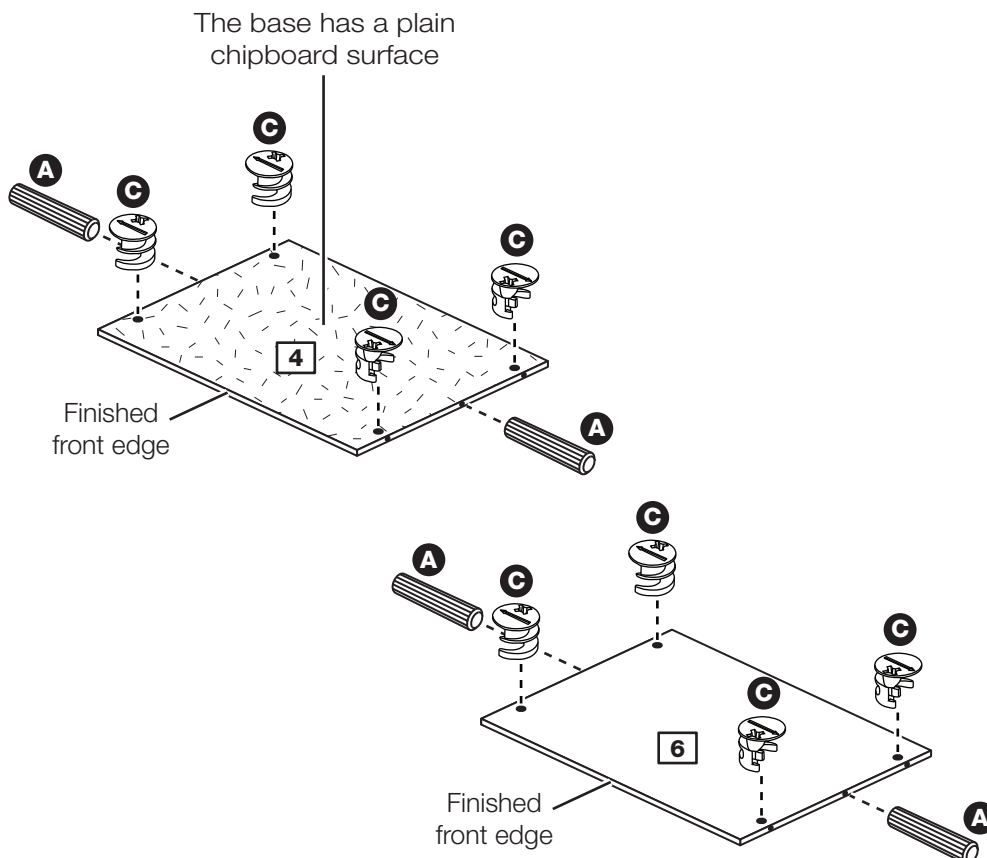

Step 11

Join the horizontal and base to the right side

Push the horizontal **6** and base **4** onto the right side **2** as shown.

Use a screwdriver to tighten the 2 large locking nuts **C** fitted to both the horizontal **6** and base **4**.

Note: Turn the large locking nuts **C** as far as they will go - more than 1/2 a turn.

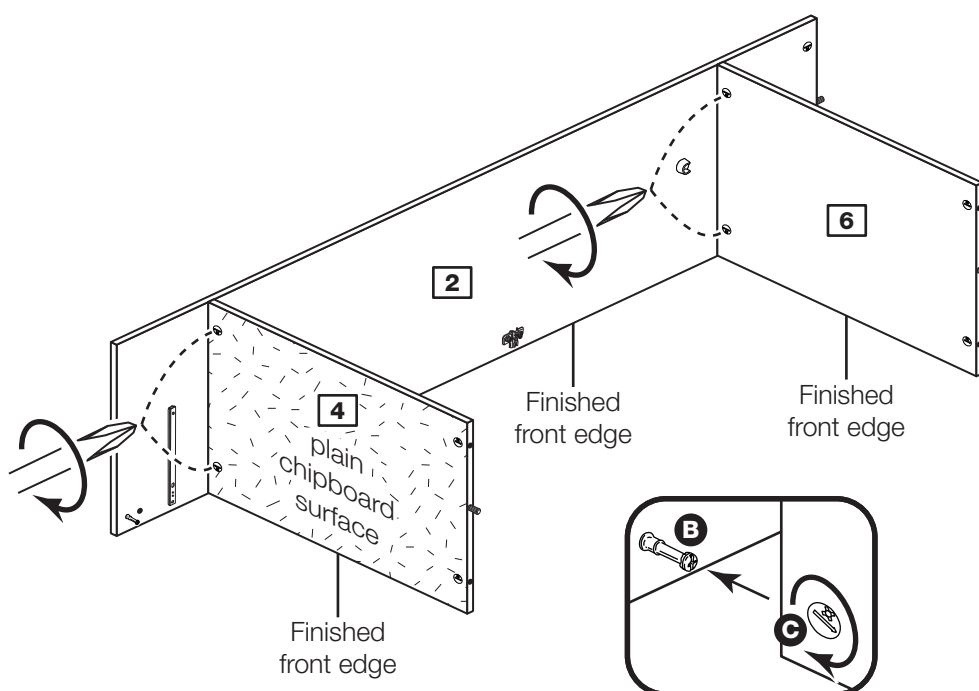

Assembly Instructions

Step 12

Prepare the plinth

Tap 2 wooden dowels **A** into the plinth **5**.

Insert 2 large locking nuts **C** into the plinth **5**.

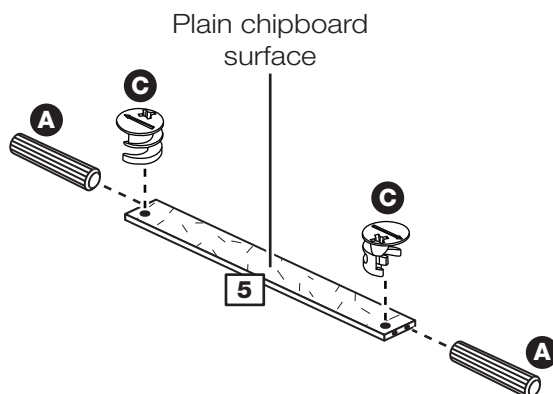

Step 13

Fit the plinth

Push the plinth **5** onto the right side **2**.

Use a screwdriver to tighten the large locking nut **C** fitted to the plinth **5**.

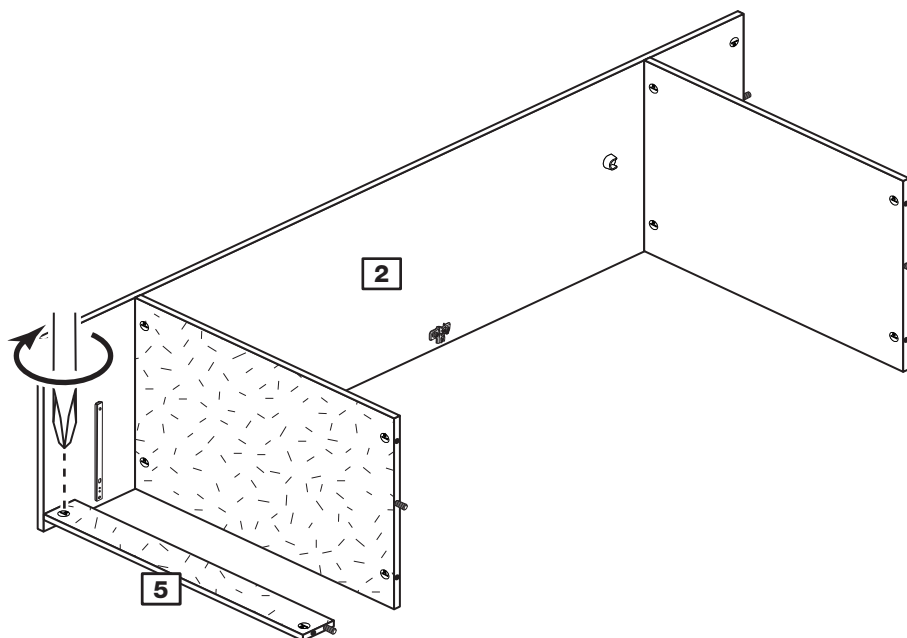

Step 14

Fit the left side

Push the left side **1** onto the assembly.

Use a screwdriver to tighten the 5 large locking nuts **C** fitted to the horizontal **6**, plinth **5** and base **4**.

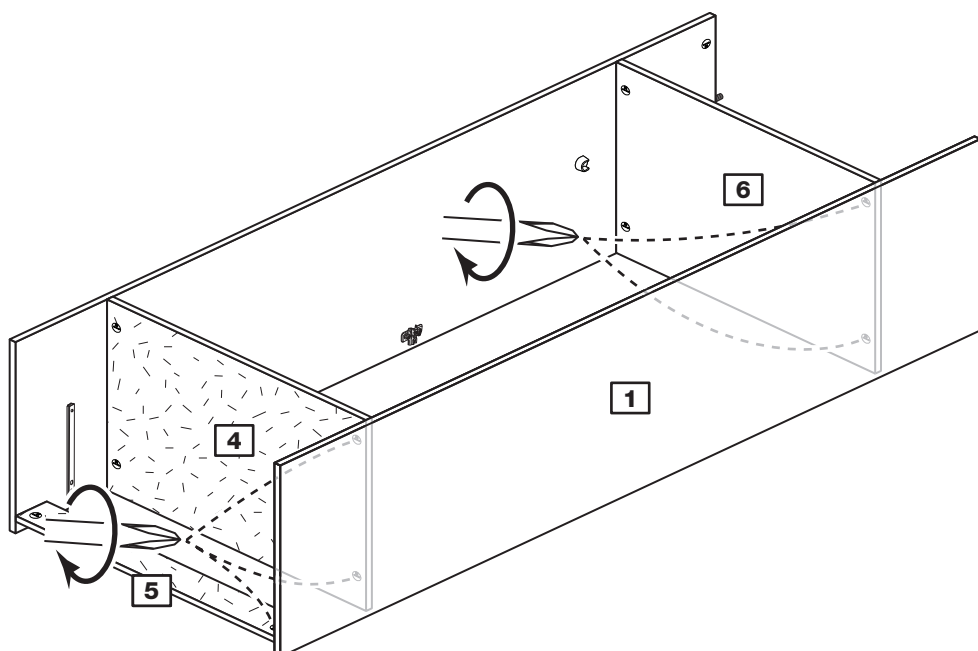

Assembly Instructions

Step 15

Prepare the top

Screw 4 metal dowels **B** into the holes shown on the top **3**.

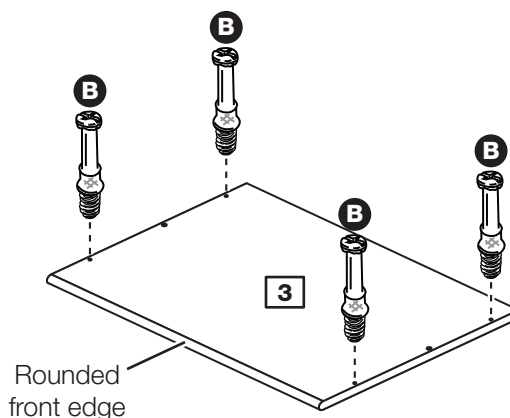

Step 16

Fit the top

Push the top **3** onto the side panels **1** and **2**.

Use a screwdriver to tighten the 4 large locking nuts **C** fitted to the side panels **1** and **2**.

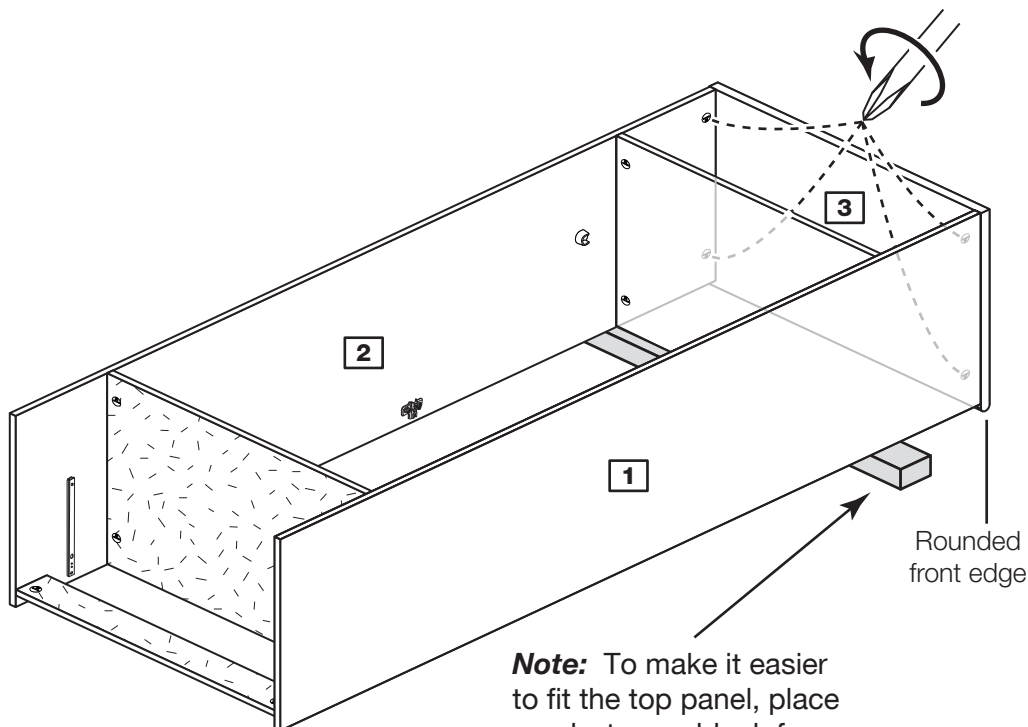

Note: To make it easier to fit the top panel, place a polystyrene block from the packaging underneath the side panels to raise the assembly.

Assembly Instructions

Step 17

Fit the back

a: Square up the unit by making sure that measurement **x** to **x** equals **y** to **y**.

b: Place the back **14** onto the unit.

Nail **P** around the outside edges of the back **14**.

Note: Nails should be spaced about 150mm apart.

Tap 2 plastic nails **R** into the bottom edge of each of the sides **1** and **2**.

Stand the unit up for the next step.



Warning: The unit is heavy. Lift with care.

a: The measurement from top corner X to bottom corner X must be equal to the measurement from top corner Y to bottom corner Y

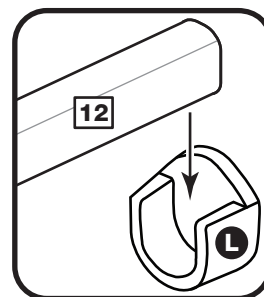
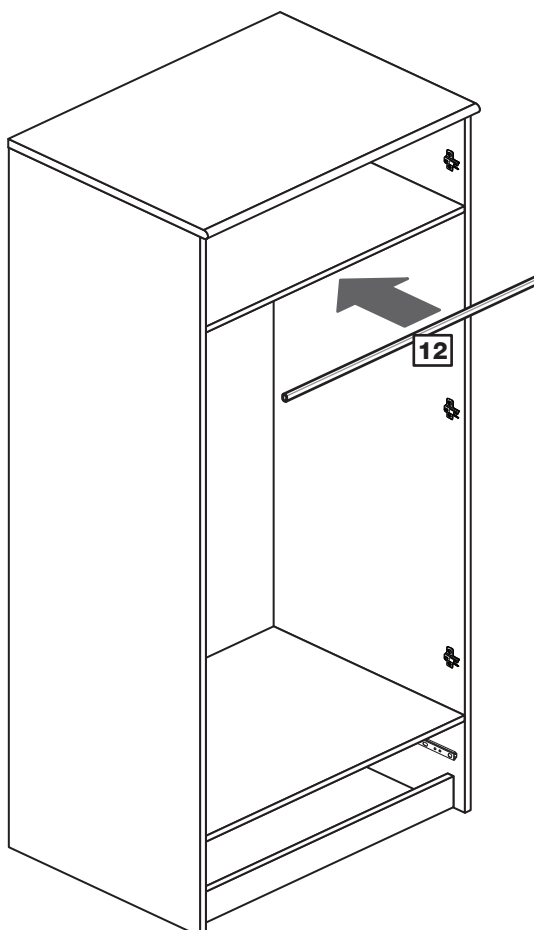
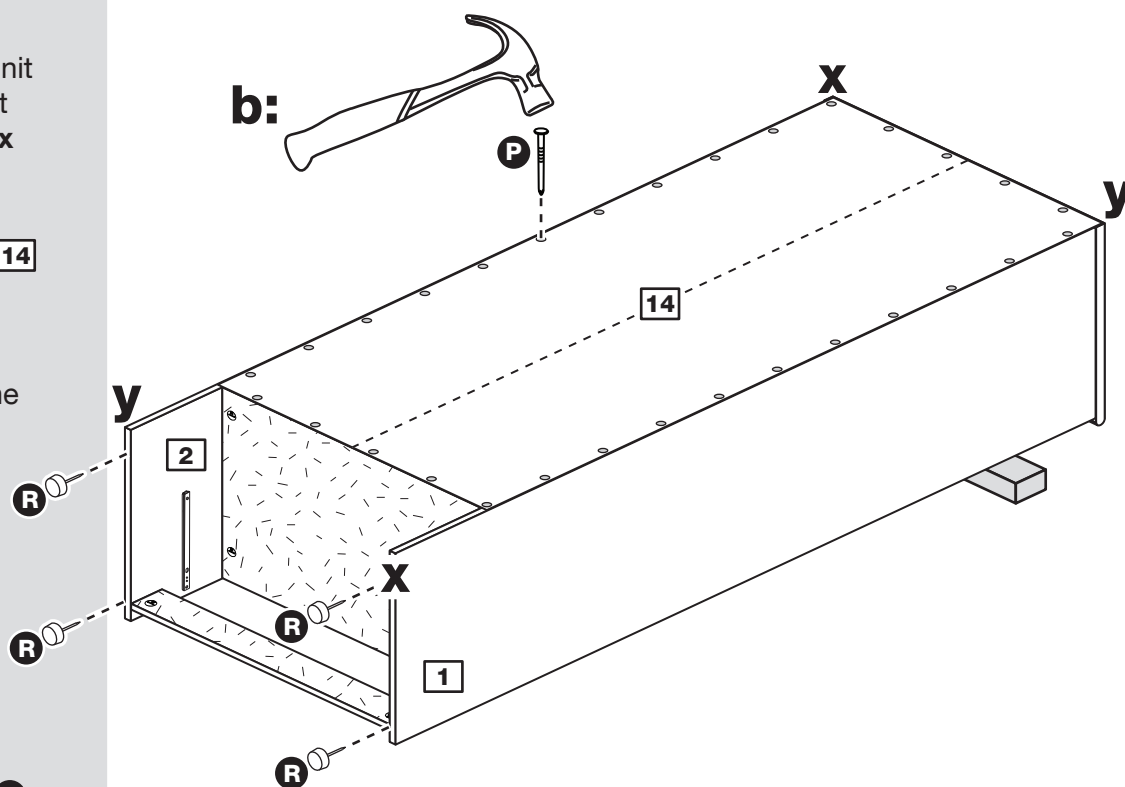

Step 18

Fit the hanging rail

Push the hanging rail **12** into the rail holders **L** fitted to the side panels.

Assembly Instructions

Step 19

Fit the drawer

Slide both the runners **O** forward and locate the drawer sides **9** and **10** between them, lining up the holes in the drawer wrap with the 2nd 'threaded' holes in the runners **O**.

Working from the inside of the drawer, insert 2 screws **G** through the drawer sides and out into the 2nd threaded hole in the runner.

Note: Do not overtighten the screws **G**. If they catch on the runner you may need to loosen them slightly.

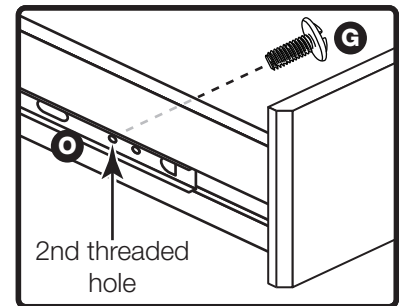
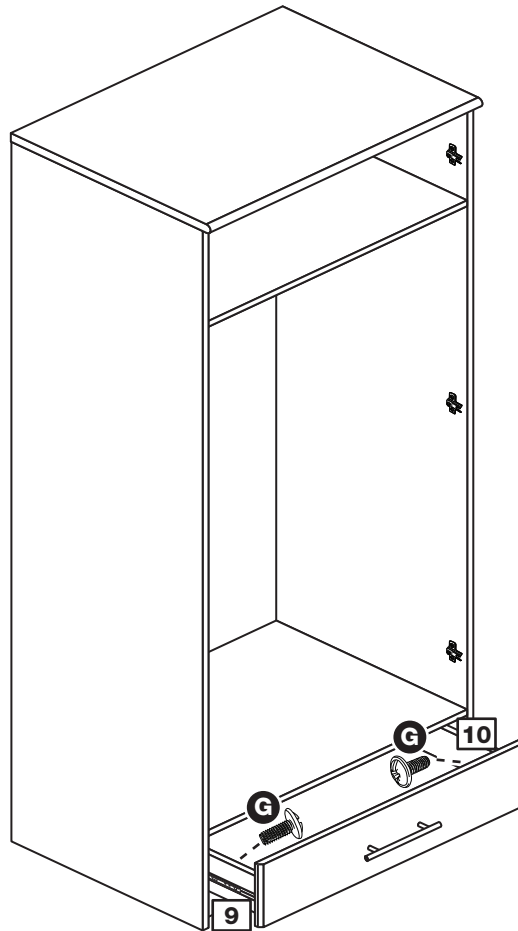

Step 20

Prepare the 2 doors

Push fit 3 hinges **N** into each of the doors **13**.

Secure each hinge with 2 screws **F**.

Note: Before securing with the screws, make sure that the hinges are positioned at 90 degrees with the edge of the door.

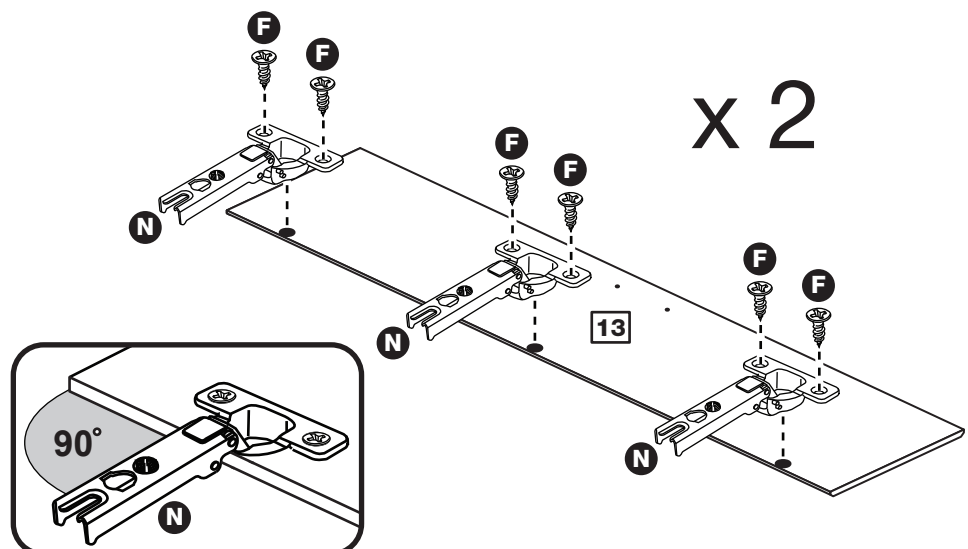

Assembly Instructions

Step 21

Fit doors and handles

Note: The easiest way to attach each door **13** is to fit the top hinge first, then align and fit the other hinges.

a: Push the hinge **N** onto the front part of the hinge plate **M**. The recess at the bottom of screw B goes into the slot in the hinge plate.

b: Keep the hinge **N** FLAT against the hinge plate **M** as you slide it across as far as it will go. Tighten screw A.

c: The hinge **N** must be flat against the hinge plate **M** prior to any adjustment.

d: The hinge **N** must NOT BE AT AN ANGLE to the hinge plate **M** when assembled. This would indicate that the recess at the bottom of screw B had not located in the slot in the hinge plate and the hinge would not be secure. Remove the hinge from the hinge plate and then re-assemble being careful to follow instructions a-c.

e: Attach a handle **Ja** to each door **13** using 2 screws **Jb**.

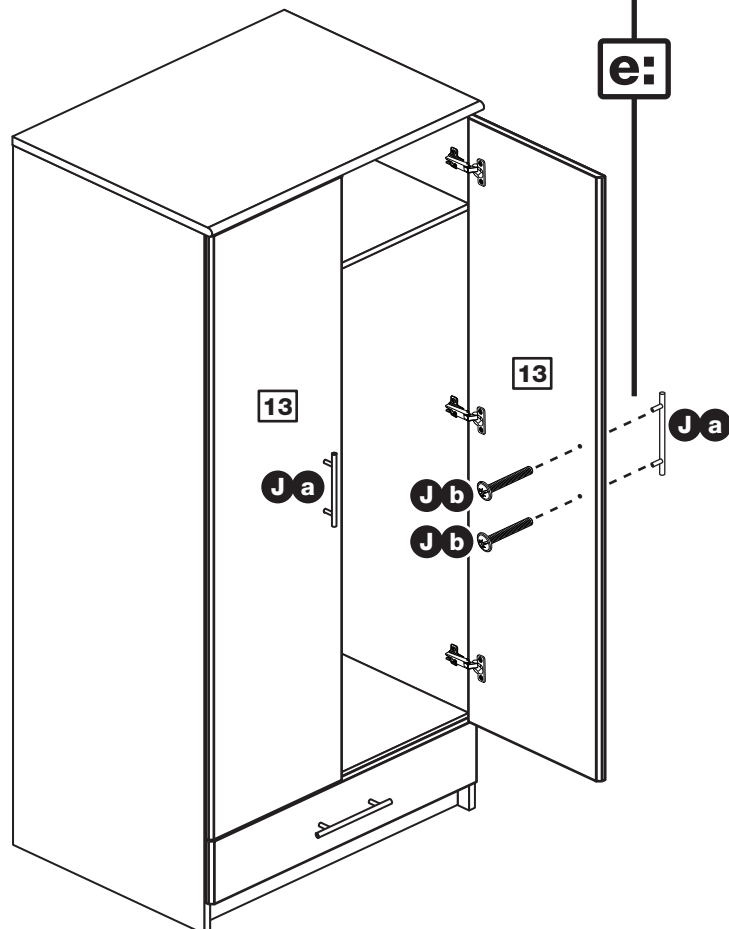
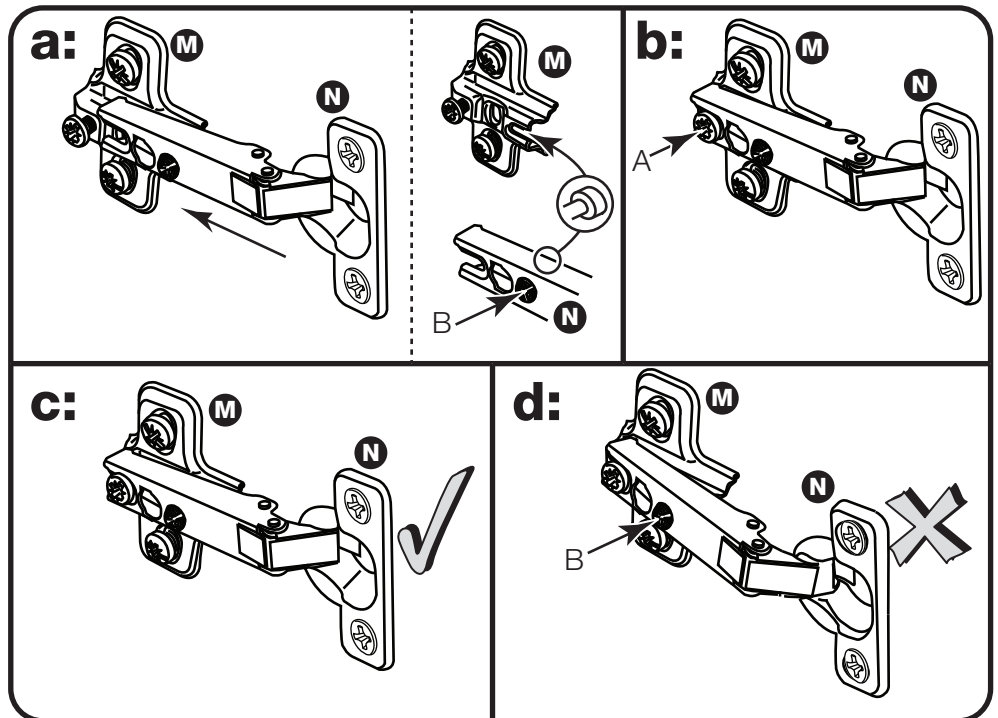

Assembly Instructions

Step 22

Adjust the doors if needed

a: Before adjusting the doors, use a spirit level to check the base (or top) of the unit is level, front-to-back and side-to-side in the 3 positions shown. Use suitable packing pieces (not supplied) to make the unit level BEFORE making any adjustment to the hinges, as shown.

b: Height adjustment.

Loosen screws A on hinge plates and move door up or down as required. Retighten screw A.

c: Forward and Back adjustment.

Loosen screw B on hinge plate and move door in or out as required. Retighten screw B.

d: Sideways adjustment.

To move door 'out' loosen screw C. To move door 'in' tighten screw C.

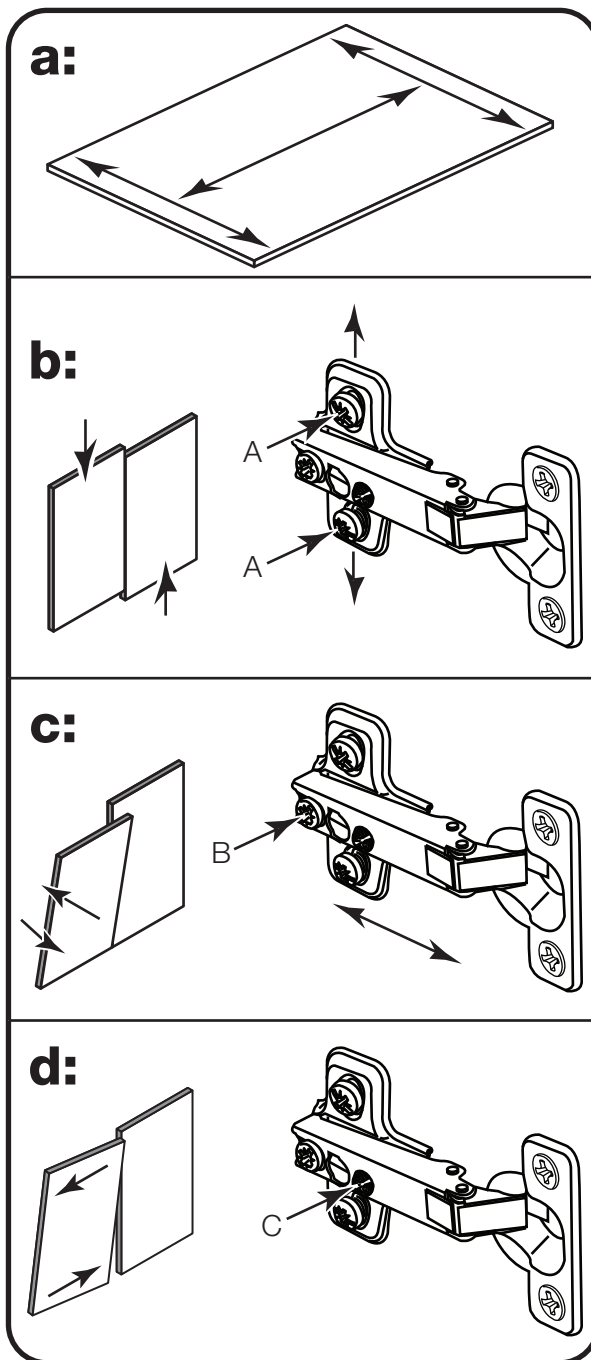

Assembly Instructions

Step 23

Fit the bracket

To prevent possible overbalancing, we recommend that this unit is secured to a suitable wall by use of the bracket **K** fitted to the top of the unit.

Fixings are not supplied, as they will need to suit the wall type and the length of screw will depend on the distance from the back of the unit to the wall.

Fix the bracket **K** loosely onto the top of the unit using screw **E** and mark the wall for the wall fixing.

Swivel the bracket **K** away from the wall and drill a hole in the wall using a suitable drill bit and fit your wall fixing.

Swivel the bracket **K** back and fix the bracket to the wall, then tighten Screw **E**.

Note: Take care when drilling the wall that you do not drill into any pipes, wires etc. If in doubt, consult an expert.



Warning: The unit is heavy. Lift with care.

Assembly is complete

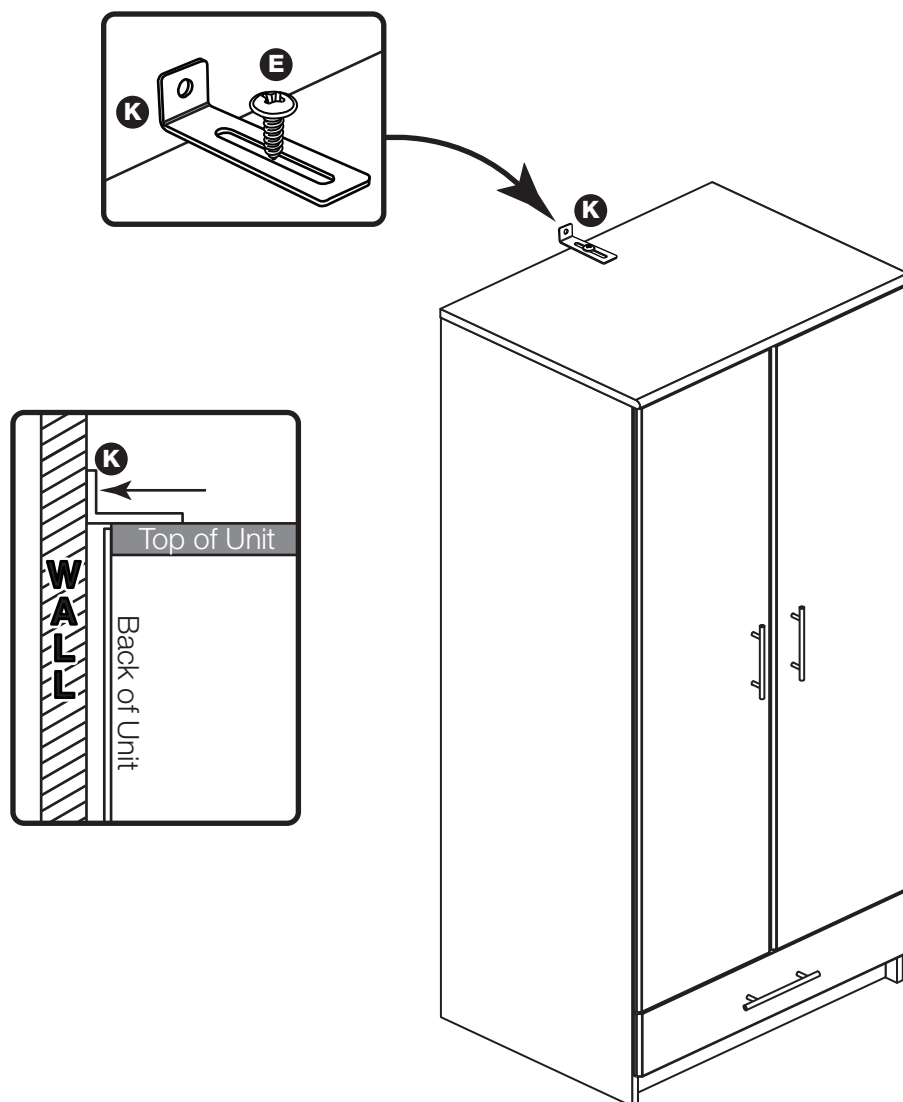

If you need help or have damaged or missing parts, call the Customer Helpline: 08456 400800 and quote the reference numbers on the component pages.

Argos Ltd, 489-499 Avebury Boulevard, Central Milton Keynes, MK9 2NW