

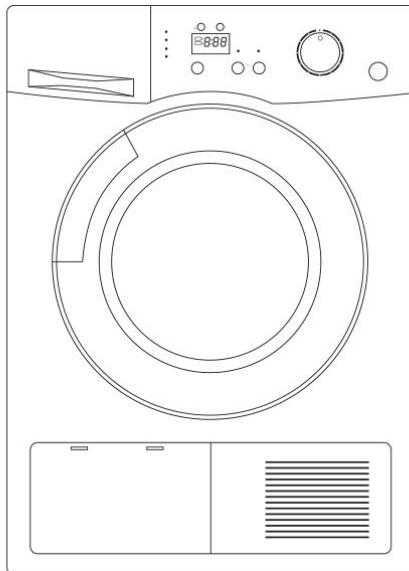

# Russell Hobbs

8kg Condenser Tumble Dryer

Instruction manual



**Model number:  
RH8CTD600(B)(R)**

**IMPORTANT:  
RETAIN FOR FUTURE REFERENCE**

For Customer Services & Spare Parts please call **0345 208 8750**  
Opening times: Monday - Friday 8am – 8pm & Saturday 9am – 1pm  
or visit us at **[www.productcareuk.com](http://www.productcareuk.com)**

## Contents

<b>Safety information</b>	.....	3 - 6
<b>Before using your appliance</b>	.....	7
<b>Control panel</b>	.....	8 - 9
<b>Installation</b>	.....	10 - 11
<b>Operating instructions</b>	.....	12 - 16
<b>Programme table</b>	.....	17
<b>Care and maintenance</b>	.....	18 - 19
<b>Trouble shooting</b>	.....	20 - 21
<b>Technical specification</b>	.....	22
<b>Product fiche</b>	.....	22
<b>Connection to mains supply</b>	.....	23
<b>Guarantee</b>	.....	24
<b>Notes</b>	.....	25 - 27



For Customer Services & Spare Parts please call **0345 208 8750**  
Opening times: Monday - Friday 8am – 8pm & Saturday 9am – 1pm  
or visit us at [www.productcareuk.com](http://www.productcareuk.com)

## Important information

- This tumble dryer is intended for **NORMAL DOMESTIC USE ONLY**.
- Adequate ventilation must be provided around the tumble dryer.
- Exhaust air must not be discharged into a flue which is used for exhausting other fumes from appliances burning gas or other fuel.
- Please note it is not recommended that the dryer is placed directly next to ovens, cookers, or other heat sources as the performance of the dryer may be affected.
- A carpet must not obstruct the ventilation openings in the base of the dryer.
- Do not stack the tumble dryer on top of other appliances .
- Any electrical work required to install the appliance should be carried out by a qualified person.
- It is important to clean the lint filter after each drying cycle or the restrictions to airflow will extend drying times and could cause the safety cut-out to trip.
- Under no circumstances should anything other than the recommended articles be placed in the tumble dryer.
- The tumble dryer should be serviced by an appointed service team with genuine parts. Please contact the service team below for assistance with any repairs.
- It is dangerous to alter or modify the product in any way other than fitting authorized accessories.
- We recommend that the appliance is unplugged each time after use. It should always be disconnected from the electricity supply when not in use for long periods of time.
- The rear of the dryer gets quite hot during use. Position the dryer so that the back is not accessible while in operation, but ensure that the sides have a space available to allow airflow. Use the hose to assist with the ventilation.



For Customer Services & Spare Parts please call **0345 208 8750**  
Opening times: Monday - Friday 8am – 8pm & Saturday 9am – 1pm  
or visit us at [www.productcareuk.com](http://www.productcareuk.com)

## Important information

- The special mains cable and plug assembly must only be replaced with a genuine part from the manufacturer, please contact the customer support team below .
- It is important to clean fluff from the window of the dryer and around the door seal after each drying cycle.
- This appliance can be used by children aged from 8 years and above and persons with reduced physical, sensory or mental capabilities or lack of experience and knowledge if they have been given supervision or instruction concerning use of the appliance in a safe way and understand the hazards involved. Children shall not play with the appliance.
- Children should be supervised to ensure they do not play with the appliance.
- The plug of the appliance must be connected to a three-core socket with an earth wire grounded properly.
- If the supply cable is damaged, it must be replaced by the manufacturer, please contact the customer support team listed below.
- Do not disconnect the plug from the socket by pulling the power supply cord. Always hold the plug when disconnecting.
- Do not attempt to disconnect the plug from the socket with wet hands.
- Do not over bend the power cord.
- Do not put too much stress or heavy weights on the power cord.
- Do not use the appliance if the power cord, socket, or plug are damaged.
- Do not install the appliance close to a fire or heat source.
- Do not rest anything burning, such as a candle, on the appliance.
- Do not install the appliance in a damp environment, the dampness may cause damage to the tumble dryer.
- Do not install the tumble dryer in direct sunlight, or in a hot environment.
- Do not use excessive, or high pressure water when cleaning the tumble dryer.
- Do not use the appliance to dry cushions, quilts, duvets, or similar items.
- Do not place items that have any type of oil soaked in to the fabric, in the tumble dryer. There is a potential the oil could catch on fire.



For Customer Services & Spare Parts please call **0345 208 8750**  
Opening times: Monday - Friday 8am – 8pm & Saturday 9am – 1pm  
or visit us at [www.productcareuk.com](http://www.productcareuk.com)

## Important information

- Make sure clothing is fully rinsed of detergent and stain remover, before placing in the tumble dryer.
- Do not put combustible liquid or solids, such as oil, gasoline, petrol and alcohol into the appliance or nearby.
- Remove all objects from pockets before use, especially potentially flammable items such as lighters and matches.
- If leakage of a combustible liquid occurs near the appliance, do not connect or disconnect the mains plug.
- This appliance is designed for domestic use only. It should not be used for purposes other than those for which it was designed.
- Only dry fabrics that are designed to be machine dried. Follow the instructions on each garment label.
- Adjust the feet so that adequate air can circulate freely under the appliance, especially if the appliance is placed on a carpeted floor.
- Do not climb on to the dryer or rest heavy objects, heating devices, or items containing water or liquid on to the dryer. They may all cause damage.
- Repairs must only be carried out by a qualified professional, if there is a problem, please contact the customer service company listed below.
- Make sure items that may cause damage do not get in to the dryer, items such as coins, safety pins, nails, screws, stones. Check the pockets on all the items of clothing.
- Check the appliance is not standing or pressing on the power cable.
- Foam rubber, latex, shower caps, waterproof textiles, rubber backed articles and any other items with foam rubber pads should not be dried in the tumble dryer.
- Always unplug the appliance after use, clean and maintain.
- Do not overload the appliance.
- Do not place clothes that are dripping wet in the tumble dryer.
- Clothes that have been in contact with volatile liquids should not be machine dried. Any fluid should be fully removed from the item before it can be dried.
- Do not dry unwashed items in the tumble dryer.
- The final part of a tumble drying cycle occurs without heat (cool down cycle) to ensure the items are not damaged. Do not stop the dryer before it has fully finished the drying cycle.



For Customer Services & Spare Parts please call **0345 208 8750**  
Opening times: Monday - Friday 8am – 8pm & Saturday 9am – 1pm  
or visit us at [www.productcareuk.com](http://www.productcareuk.com)

## Warnings

**WARNING:** Never stop a tumble dryer before the end of a drying cycle, unless the items are removed very quickly

- Do not use a two-way adaptor, or extension lead. The dryer must be connected to its own socket.
- Do not block the air inlets at the front, base, rear and side of your dryer.
- Do not allow fluff to accumulate around the tumble dryer. There is a risk the fluff may cause a fire.
- Do not exceed the recommended maximum load.
- Do not place articles in the dryer if anything other than a water solution has been used in the cleaning process.
- Do not attempt to dry dripping wet articles.
- Do not use the tumble dryer if you suspect that it is damaged in any way. Under no circumstances should you attempt to repair the appliance yourself. Repairs carried out by inexperienced persons may cause serious injury. Contact the helpline on the telephone number listed below.
- Do not let children play with the packaging supplied with this appliance.
- Do not handle laundry in the dryer, until it has stopped completely.
- Check the dryer contains only laundry before closing the door to start it working.



For Customer Services & Spare Parts please call **0345 208 8750**  
Opening times: Monday - Friday 8am – 8pm & Saturday 9am – 1pm  
or visit us at [www.productcareuk.com](http://www.productcareuk.com)

## Before using your appliance

Before installation, check that all parts are present. If any parts are missing, please contact the product care service team on: 0345 208 8750.

### Feature Diagram

Note: The drawings in the book may vary from your dryer. They are designed to show the different features of all models covered by this book. Your model may not include all features.

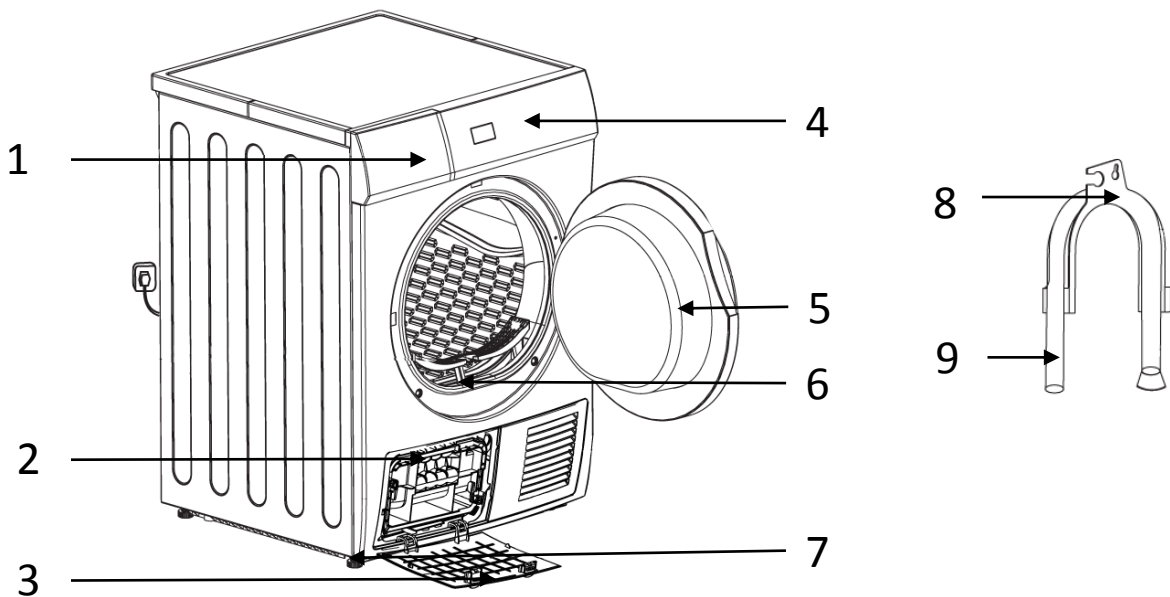

- |                       |                    |
|-----------------------|--------------------|
| 1. Water tank & cover | 6. Fluff filter    |
| 2. Condenser unit     | 7. Adjustable feet |
| 3. Condenser cover    | 8. Hose holder     |
| 4. Control panel      | 9. Drain hose      |
| 5. Door               |                    |



For Customer Services & Spare Parts please call **0345 208 8750**  
Opening times: Monday - Friday 8am - 8pm & Saturday 9am - 1pm  
or visit us at [www.productcareuk.com](http://www.productcareuk.com)

## Control panel

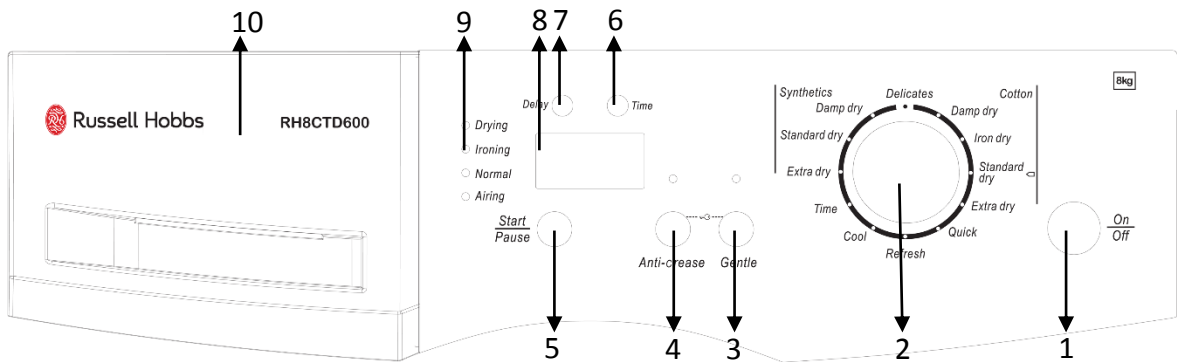

### 1. On/Off (see page 13)

Press the button to turn the dryer on and off

### 2. Programme dial (see page 14 & 17)

Choose the correct programme for the load by selecting one of the 12 programmes.

### 3. Gentle button & indicator (see page 13)

To reduce the temperature your laundry is dried at. When the indicator is lit constantly it indicates that the gentle function has been activated.

### 4. Anti-crease button & indicator (see page 14)

To reduce creasing of clothes. When the indicator is lit constantly it indicates that the anti-crease function has been activated.

### 5. Start/pause button (see page 14)

Press to start or pause the drying cycle.

### 6. Time button (see page 14)

Press to choose the amount of time you want the time programme to last (20 – 60 mins). The time should be selected prior to pressing the start button.

### 7. Delay button (see page 14)

Press to choose the amount of time you want the selected programme to be delayed by (1 – 24 hours). The delay time should be selected prior to pressing the start button.



For Customer Services & Spare Parts please call **0345 208 8750**  
Opening times: Monday - Friday 8am – 8pm & Saturday 9am – 1pm  
or visit us at [www.productcareuk.com](http://www.productcareuk.com)



### **8. LED display (see page 15)**

The displays will show the below information:

- Approximate time duration of a programme when selected
- Counts down the time of a programme after it has been started
- How long a programme has been delayed by (if selected).
- Error codes, warning symbols and if the child lock has been activated

### **9. Drying status indicators (see page 15)**

Indicates which part of the drying process the selected programme is at.

### **10. Water tank & cover (see page 19)**

The water extraction from the wet laundry that has been dried deposits in a water tank at the top left corner under the water tank cover. For the dryer to operate at optimum efficiency the water tank should be emptied after every drying cycle.

## Installation

Your condenser tumble dryer removes humidity by using two separate air flows. Air recirculates inside the machine and is heated. Then it is passed through the damp clothes where it picks up moisture. Damp air is passed through the condenser in one direction while the room air is passed through the condenser in the other direction. This causes the moisture in the air to condense into water which is then pumped to the water tank or out through the hose.

For convenience, dryers are often positioned close to the washing machine, so the laundry can be easily transferred. The tumble dryer will expel some moist air, so make sure the room is well ventilated. Install the dryer in a clean environment, and make sure there are no obstructions around any vents. It should be placed on a firm level surface, this helps keep noise and vibration to a minimum.

There should be no movement from the dryer. Adjust the feet underneath the dryer to make sure it is completely stable. This can be done by hand or with the help of a screwdriver. There is a hole in the side of each foot in which a screwdriver can be inserted and used to rotate the foot. Do not remove the feet from the dryer.

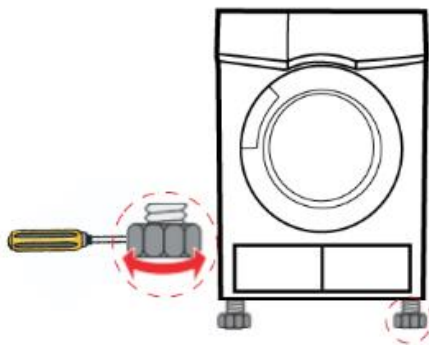

The tumble dryer works best in a room between 5°C and 35°C.

In products equipped with a condenser unit the water accumulated during the drying cycle is collected in the water tank. For the dryer to operate at optimum efficiency the water tank should be emptied after every drying cycle. Alternatively you can directly send the accumulated water out through the water drain hose supplied with the machine instead of emptying the water tank after each drying cycle.

Note: when cleaning the condenser unit you will notice that an amount of water will be in the tray it has just been removed from. This is expected and normal, this is where the hot air is condensed and the water is then pumped to the water tank.



For Customer Services & Spare Parts please call **0345 208 8750**  
Opening times: Monday - Friday 8am – 8pm & Saturday 9am – 1pm  
or visit us at [www.productcareuk.com](http://www.productcareuk.com)

## Installation

### Connection to water drain;

1. Remove the hose on the rear of the machine by pulling it out from its end. Do not use any tools to take out the hose.

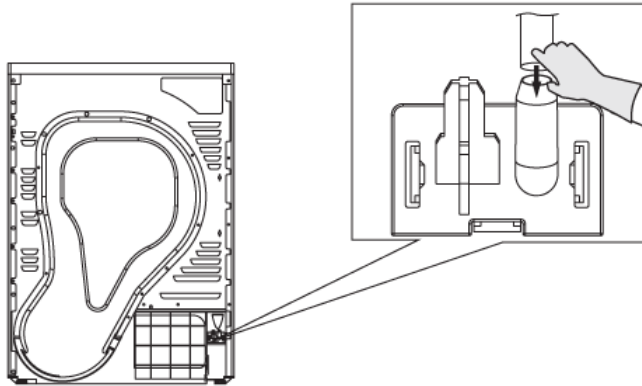

2. Connect the drain hose supplied with the machine to the pipe fitting.

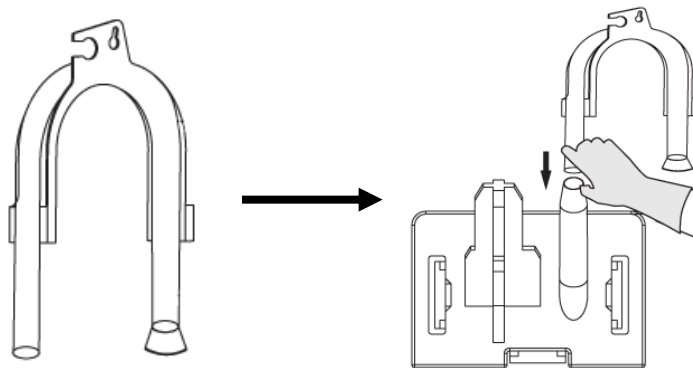

3. The other end of the drain hose can be directly connected to the wastewater drain or to the washbasin. The fitting must always be secured in all types of connections. Your house may be flooded if the hose gets out of its housing during water discharge.

#### **Important:**

- The hose should be attached to a height of maximum 100 cm.
- You must be careful not to pinch or bend the hose.
- The end of the hose should not be bent, it should not be stepped on and it must not be folded between the drain and the machine.



For Customer Services & Spare Parts please call **0345 208 8750**  
Opening times: Monday - Friday 8am – 8pm & Saturday 9am – 1pm  
or visit us at [www.productcareuk.com](http://www.productcareuk.com)

## Operating instructions

**IMPORTANT NOTE - If you are drying laundry that weighs less than 1kg (small loads) when wet, then select the 1hr function to dry clothes.**

Remove all the packaging material, including any material inside the drum.

Before using the appliance for the first time, it is advised to place two damp clothing articles inside the drum and dry them for 1 hour. There may be some dust in the drum of the tumble dryer, and this will help remove the dust.

### Sensor controlled drying

The appliance detects the moisture in the load automatically and adjusts the drying time according to the amount of laundry that has been loaded. Simply select a programme according to the laundry and dryness level you require (for example Cotton damp dry) and the dryer will run until the required dryness level is reached for the weight of laundry that has been put into it. This only applies to Cotton, Synthetic, Delicate and Quick programmes.

**Step 1** - Open the door and place the laundry in the drum, one item at a time. Lightly shake and loosen the clothing to prevent it getting tangled.

**Important note:** Do not overload your dryer. The following table lists some common items and their approximate weight when wet, consider this when loading the dryer. Do not overload.

Quilt cover	700g	Shirt	600g
Sheet	500g	T-shirt	200g
Pillow case	200g	Blouse	100g
tablecloth	250g	Bathrobe	1200g
Napkin	100g	Night gown	200g
Bath towel	1200g	Pyjamas	500g
Tea towel	100g	Underwear	100g

**Step 2** - Close the door, ensuring no items are trapped in the door.



For Customer Services & Spare Parts please call **0345 208 8750**  
Opening times: Monday - Friday 8am – 8pm & Saturday 9am – 1pm  
or visit us at [www.productcareuk.com](http://www.productcareuk.com)

## Operating instructions

**Step 3** – Switch on the dryer and select the required programme. Press the start/stop button and the airing indicator will light up on the dryer status light indicators. The drum will begin rotating and will stop when the selected programme has finished. Each setting has the availability to add anti-crease and time delay to them but these have to be selected prior to the drying cycle being confirmed (they cannot be added or changed mid-cycle). Once a programme has finished the buzzer will sound to confirm it has ended.

To change a programme that has already started, cancel the first programme by pausing and turning the machine off, before turning the machine back on to select the desired programme.

If the door is opened during a cycle the dryer will stop. To restart, close the door and press the start/pause button.

When drying large items such as sheets, we suggest you periodically stop the dryer to redistribute the load.

There is an automatic cool down period at the end of every cycle, during which the heater is switched off. This helps to minimize creasing, and must always be used fully to avoid the risk of fire. If the laundry is not removed at the end of the cycle the dryer will tumble the clothes every 10 minutes for up to 30 minutes to reduce the risk of the clothes creasing. If the anti-crease function is selected with a programme then the dryer will tumble the clothes every 10 minutes for up to 2 hours after the programme has ended.

### On/off

Press the button to turn the dryer on and off

### Programmes

Turn the programme dial until the required programme is highlighted, There are 12 programmes and details of these are shown in the programme table that is on page 16

### Gentle

This button must be pressed prior to the drying cycle being started. This function will reduce the temperature that the laundry will be dried at.

### Gentle indicator

When lit constantly it indicates that the gentle heat function has been activated.



## Operating instructions

### Anti-crease

This button must be pressed prior to the drying cycle being started. This function will reduce the creasing of clothes.

### Anti-crease indicator

When lit constantly it indicates that the anti-crease function has been activated.

### Child Lock

To use the child lock function you must hold the gentle and anti crease buttons at the same time for 4 seconds once a cycle has started. This will cause all orders to be ignored except the power on/off, until the child lock is removed by holding both buttons for a further 4 seconds.

### Time

This button must be pressed prior to the drying cycle being started and can only be used when the Time programme has been selected. It will allow you to change the time from 20 to 60 minutes.

### Delay

This button must be pressed prior to the drying cycle being started. This function will allow you to delay the start of the drying programme by 1 – 24 hours. Press the button until your required time delay is shown on the display and delay icon will light up, you must then press the start/pause button.

### Start/pause button

This button must be pressed to start the dryer after selecting the desired programme. If the door of the dryer is opened during a cycle, the start/pause button must be pressed again to continue the cycle. At this point the light flashes to remind you that the start button needs to be pressed again.



## Operating instructions

### LED display

The displays will show the below information:

- Approximate time duration of a programme when selected
- Counts down the time of a programme after it has been started: the REMAIN icon will light up to indicate the programme time is counting down.
- How long a programme has been delayed by (if selected): the DELAY icon will light up to indicate the delay time is counting down.
- Error codes (please see page 21), warning symbols (please see page 21), and if the child lock has been activated



### Drying status indicators

Indicates which part of the drying process the selected programme is at. There is drying, ironing, normal and airing. The indicator of the appropriate drying process will light up when the selected programme is at that part of the process





**ALWAYS CLEAN THE FLUFF FILTER AFTER EACH USE.** Failure to do so could cause the safety cut-out to operate.

### Reversing the Door

The door cannot be reversed

## Operating instructions

- Never tumble dry the following; Delicate items such as net curtains, woollen items, silk items, items with metal trims, nylon tights, bulky items such as blankets, or sleeping bags, feather quilts and items containing or including rubber foam.
- Follow the instructions on the garment label;

	Tumble dry
	Normal dry
	Delicate drying
	<b>Do Not tumble dry</b>

- To prevent some items getting tangled, make sure zips, press studs, and hooks are closed, to try and prevent any tangling with other items.
- Do not over dry laundry, by not over drying it avoids creasing and saves energy.
- Avoid drying dark clothes with light coloured fluffy items, the fluff will be noticeable on the dark clothing.
- Make sure the laundry is thoroughly spun before tumble drying.



## Programme table

Programmes	Clothing type	Capacity (KGs)	Approximate amount of remaining humidity	Approximate time (mins)
Cotton	Damp	8	-5% ~ 1%	65
	Iron		-3%~3%	90
	Standard		8%~16%	130
	Extra		12%~24%	150
Synthetics	Damp	3.5	-3%~3%	42
	Standard		-1%~5%	57
	Extra		6%~20%	60
Delicate	Delicate items, machine washable woollens and hand washable items	3	0%~6%	60
Time	High heat setting programme that can last for 20 – 60 mins. Ideal for laundry that weighs less than 1kg (small loads)	3	/	20 - 60
Cool	Low heat setting programme that runs for 30 minutes. Ideal for small loads of delicate items	3	/	30
Quick	Cottons and synthetics that need to be dried quickly and daily	3	/	65
Refresh	Clothes that have been kept at closed environments for a long time (programme only ventilates it does not use any heat)	1	/	32

**Important note:** the times shown in the table are guidelines, the time of each programme will adjust according to the load that is being dried.

## Care and maintenance

**ALWAYS CLEAN THE FILTER AFTER EACH USE.** Failure to do so could cause the safety cut-out to operate.

- Pull the filter upwards from the appliance.

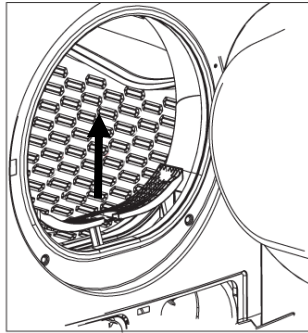

- Open the filter and remove any threads or fluff by hand or with a soft brush.

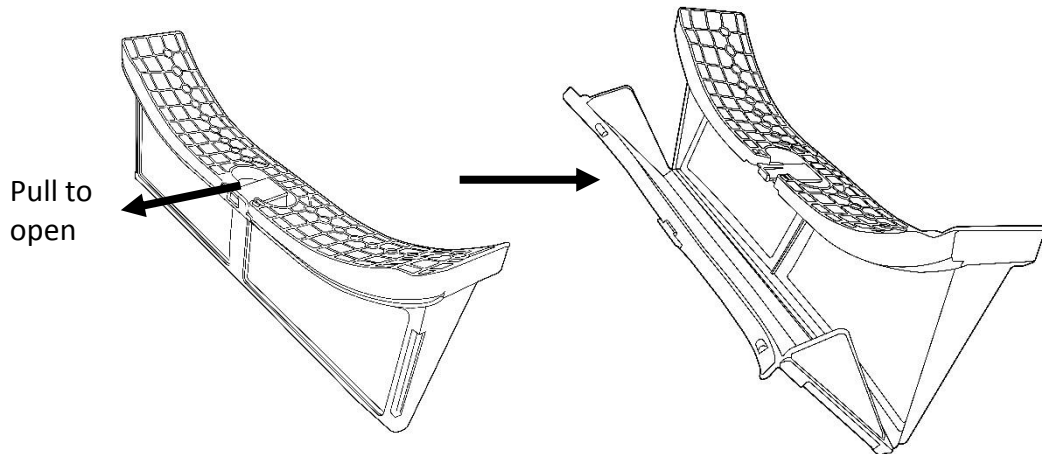

- Close the filter and slide it back into place.
- Wash the filter occasionally in detergent solution using a soft brush to remove small particles.
- If your filter becomes damaged, replace it to ensure no damage is caused to the dryer.



For Customer Services & Spare Parts please call **0345 208 8750**  
Opening times: Monday - Friday 8am - 8pm & Saturday 9am - 1pm  
or visit us at [www.productcareuk.com](http://www.productcareuk.com)

## Care and maintenance

### Emptying the water tank.

The water extraction from the wet laundry that has been dried deposits in a water tank at the top left corner. Fully remove the water tank and empty the contents down a sink, then clean the tank and replace. For the dryer to operate at optimum efficiency the water tank should be emptied after every drying cycle

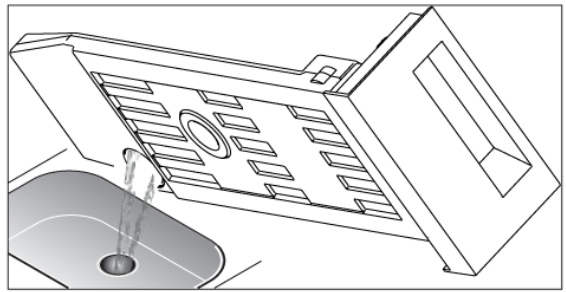
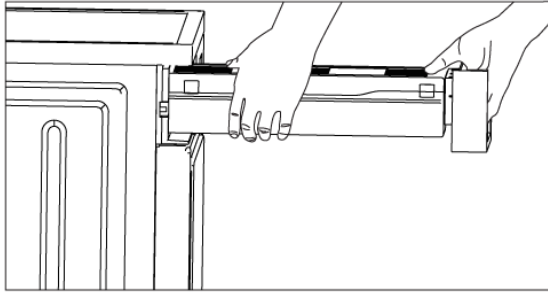

### Cleaning the condenser

It is recommended the condenser is cleaned regularly (approximately once every 3 months or once a month if used very frequently during the autumn and winter months.)

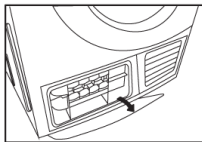

Open the condenser cover.

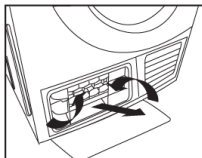

Remove the lock rods and pull out the condenser.

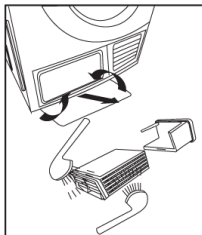

Clean the condenser with water and a soft brush thoroughly, then replace it in the dryer.

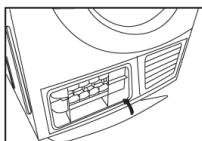

Close the condenser unit cover.



8For Customer Services & Spare Parts please call **0345 208 8750**  
Opening times: Monday - Friday 8am – 8pm & Saturday 9am – 1pm  
or visit us at [www.productcareuk.com](http://www.productcareuk.com)

## Trouble shooting

If the clothes are not dry after normal drying time:

- If you are drying laundry that weighs less than 1kg (small loads) when wet. Then the Time programme must be used and the time set to 60 minutes
- Check that you used the correct programme is being selected.
- Check the water tank is not full or close to being full.
- Check that the lint/fluff filter has been cleaned. A blocked filter will restrict the airflow.
- Check that the condenser cover and unit are clear of any obstructions. If needed give both a clean.
- Check that your dryer is heating - below the door to the left side should feel warm to the touch after the first 10-15 minutes of its programme.

If your machine does not work check the following before calling a service engineer:

- Check that the machine has the correct weight load in the drum before starting the appliance.
- Check that there is a supply of electricity or the machine is plugged in and the power switched on.
- Check that the door has been properly closed and the machine is switched on (start button pressed, if fitted).
- The child lock has been activated.
- Check the fuse in the plug.



Laundry has shrunk, become felted or deteriorated.

- Programme suitable for the laundry type might have not been used.

Only dry laundry which is suitable for drying in your machine after checking the labels on your clothes. Also select a programme and dryness level suitable for the laundry type to dry your clothes.



## Warnings and error codes

Problem	Reason	Solution
 FILTER is flashing	Water tank full or pump error	Empty the water tank, if the symbol still flashes after the water tank has been emptied then there may be a problem with the pump  Contact product care.
 TANK is flashing	Airflow block	Clean the fluff filter and the condenser unit. Also check that there is nothing blocking the flow of air in front of the condenser unit.
E30 is flashing on the display and there is a beep every 15 minutes	Heater or thermostat error	Contact Product Care
E32 is flashing on the display and there is a beep every 15 minutes	Humidity sensor error	Contact Product Care
E33 is flashing on the display and there is a beep every 15 minutes	Temperature sensor error	Contact Product Care
E34 is flashing on the display and there is a beep every 15 minutes		Contact Product Care



For Customer Services & Spare Parts please call **0345 208 8750**  
 Opening times: Monday - Friday 8am – 8pm & Saturday 9am – 1pm  
 or visit us at [www.productcareuk.com](http://www.productcareuk.com)

## Technical specification

Brand	Russell Hobbs
Model	RH8CTD600(B)(R)
Type of dryer	Condenser
Energy efficiency rating	B
Capacity (kg)	8
Weight (kg)	40.5
Dimensions (CMs)	(H)84.5 x (W)59.5 x (D)61.5

## Product fiche

Energy consumption 561.0kWh per year, based on 160 drying cycles of the standard cotton programme at full and partial load, and the consumption of the low-power modes. Actual energy consumption per cycle will depend on how the appliance is used.

Automatic or non- automatic: Automatic

EU Ecolabel: N/A

Energy consumption of the standard cotton programme at full load: 4.74 kWh

Energy consumption of the standard cotton programme at partial load: 2.56 kWh

Power consumption of the off-mode (Po): 0.28 W

Power consumption of the left-on mode (Pl): 1.72 W

Duration of the left-on mode: 10 min

The 'standard cotton programme' used at full and partial load is the standard drying programme to which the information in the label and the fiche relates, that this programme is suitable for drying normal wet cotton laundry and that it is the most efficient programme in terms of energy consumption for cotton.

Weighted programme time of the standard cotton programme at full and partial load: 112 min

Programme time of the standard cotton programme at full load: 140 min

Programme time of the standard cotton programme at partial load: 90 min

Condensation efficiency class B on a scale from G (least efficient) to A (most efficient).

Average condensation efficiency of the standard cotton programme at full load: 80.1%

Average condensation efficiency of the standard cotton programme at partial load: 80.1%

Weighted condensation efficiency for the standard cotton programme at full and partial load: 80.1%

Sound power level for the standard cotton programme at full load: 69dB



For Customer Services & Spare Parts please call **0345 208 8750**  
Opening times: Monday - Friday 8am – 8pm & Saturday 9am – 1pm  
or visit us at [www.productcareuk.com](http://www.productcareuk.com)

## Connections to the mains supply

### **WARNING-** THIS APPLIANCE MUST BE EARTHED

This appliance is designed to operate from a mains supply of AC230V ~ 50HZ.  
Check that the voltage marked on the product corresponds with your supply voltage.

This product is fitted with a 13A plug complying with BS1363.

If this plug is unsuitable or needs to be replaced, please note the following:

Important: The wires in the mains lead are  
Coloured in accordance with the following code:  
GREEN/YELLOW - EARTH  
BLUE - NEUTRAL  
BROWN - LIVE



For UK use only – Plug fitting details (where applicable):

As the colours of the wires in the mains lead of this appliance may not correspond with the coloured markings identifying the terminals in your plug, proceed as follows:

The GREEN/YELLOW wire is the EARTH and must be connected to the terminal which is marked with the letter E or by the earth symbol or coloured GREEN or GREEN/YELLOW.

The BLUE wire is the NEUTRAL and must be connected to the terminal marked with the letter N or coloured BLACK.

The BROWN wire is the LIVE wire and must be connected to the terminal marked with the letter L or coloured RED.

Always ensure that the plug cord grip is fastened correctly.

If a 13A (BS1363) fused plug is used it must be fitted with a 13amp fuse conforming to BS1362 and be BSI or ASTA approved.

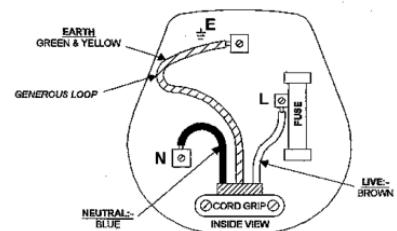

For Customer Services & Spare Parts please call **0345 208 8750**  
Opening times: Monday - Friday 8am – 8pm & Saturday 9am – 1pm  
or visit us at [www.productcareuk.com](http://www.productcareuk.com)

## Guarantee

This product is guaranteed for 12 months from the date of the original purchase. If any defect arises due to faulty materials or workmanship the faulty product must be returned to the place of purchase.

Refund or replacement is at the discretion of the retailer.

### **The following conditions apply:**

- The product must be returned to the retailer with the original proof of purchase.
- The product must be installed and used in accordance with the instructions contained in this instruction guide and any other instructions for use which are supplied.
- It must be used for domestic purposes only and for its intended use.
- This warranty does not cover wear and tear, damage, misuse or consumable parts.

**This does not affect your statutory rights.**

Produced for:

**G2S Limited,**

**Wigan,**

**WN2 4AY**



For Customer Services & Spare Parts please call **0345 208 8750**  
Opening times: Monday - Friday 8am – 8pm & Saturday 9am – 1pm  
or visit us at [www.productcareuk.com](http://www.productcareuk.com)



## Notes



**Russell Hobbs**

For Customer Services & Spare Parts please call **0345 208 8750**  
Opening times: Monday - Friday 8am – 8pm & Saturday 9am – 1pm  
or visit us at [www.productcareuk.com](http://www.productcareuk.com)

## Notes



For Customer Services & Spare Parts please call **0345 208 8750**  
Opening times: Monday - Friday 8am – 8pm & Saturday 9am – 1pm  
or visit us at [www.productcareuk.com](http://www.productcareuk.com)

## Notes



**Russell Hobbs**

For Customer Services & Spare Parts please call **0345 208 8750**  
Opening times: Monday - Friday 8am – 8pm & Saturday 9am – 1pm  
or visit us at [www.productcareuk.com](http://www.productcareuk.com)

For Customer Services & Spare Parts  
please call

**0345 208 8750**

Opening times: Monday - Friday  
8am – 8pm & Saturday 9am – 1pm

or visit us at

**[www.productcareuk.com](http://www.productcareuk.com)**

Revision 1



This symbol is known as the 'Crossed-out wheellie bin Symbol'. When this symbol is marked on a product/batteries, it means that the product/batteries should not be disposed of with your general household waste. Only discard electrical/electronic/battery items in separate collection schemes, which cater for the recovery and recycling of materials contained within. Your co-operation is vital to make sure the success of these schemes and for the protection of the environment. For your nearest disposal facility, visit [www.recycle-more.co.uk](http://www.recycle-more.co.uk) or ask in store for details.

We reserve the right due to possible changes to design to alter the instruction manual without prior notice.