

Pro Fitness Treadmill W Speaker

Assembly & User Instructions- Please keep for future reference

331/7226

PRO FITNESS

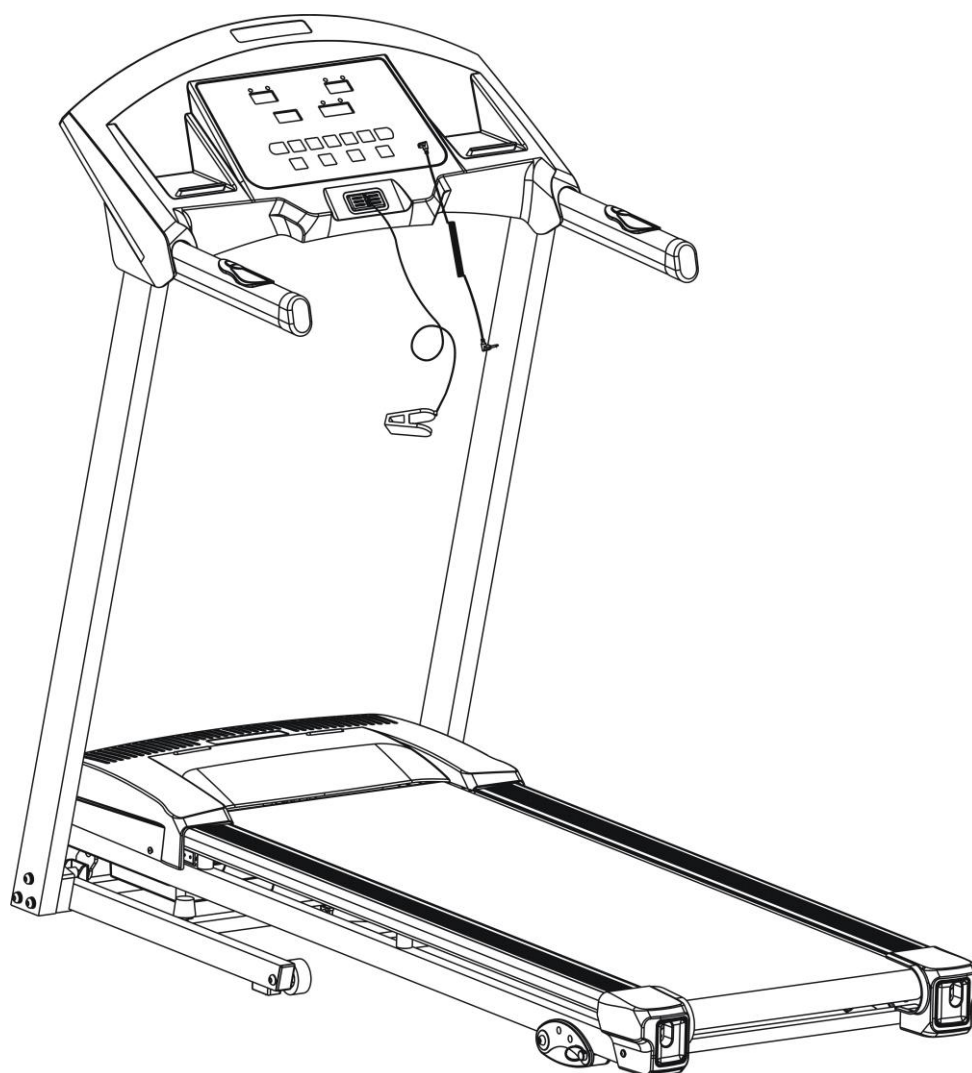

Important – Please read these instructions fully before assembly or using

These Instructions contain important information which will help you get best from your equipment and ensure safe and correct assembly, use and maintenance.

If you need help or have damaged or missing parts, call the **Customer Service: 0345 6001714**
www.argos-support.co.uk/

Contents

Before you Begin	2
General Safety Information	3
Safety Information	4
Components-Parts	5
Components-Fixings	6
Before Assembly	7
Assembly Instructions	8-11
How to Start	12
Computer Instruction	13
Computer Operation	14-21
Limited Warranty	22
Maintenance	23-27
Exercising Information	28-31
Care and Maintenance	32
Exploded Parts Diagram	33
Exploded Parts List	34-35

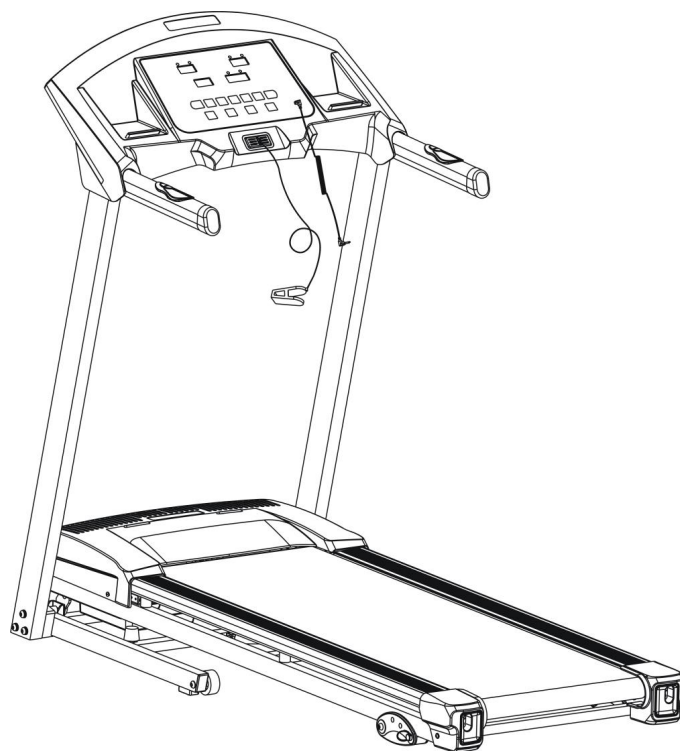

Before you Begin

PRO FITNESS

Precautions

Congratulations for selecting the 3317226 Treadmill from Roger Black. Whether you are an accomplished athlete seeking to maintain peak performance or a beginner realizing the benefits of exercise for the first time, the 3317226 Treadmill will help you to achieve your goals.

In the meantime, remember that the benefits of exercise are many and varied including higher energy levels, reduced stress, improved self-esteem, clearer and more radiant skin, greater cardiovascular efficiency, higher metabolic rate, and improved body posture – all of which can result in a longer and more enjoyable life.

While purchasing the 3317226 Treadmill will not do all of this alone, it is an important step towards understanding and achieving the benefits of exercise.

- When you open the carton, please do not hold

the handle grip to carry the treadmill from the carton. Assemble the treadmill and take out from the carton, failure to do this will damage the treadmill console .

- Do not under any circumstance turn the machine on its side unless in the fold up position. Failure to follow this instruction could lead to serious injury from base frame being sprung open with considerable force.

All Roger Black products are manufactured to the highest specifications and this instruction manual should enable you to assemble the 3317226 Treadmill and commence your workout program. If, however, you have any additional questions, please call out UK **Customer Service: 0345 600 1714** or go to **www.argos-support.co.uk/**. To help us assist you, please quote the product model number and serial number when calling. The model number is 3317226. The serial number can be found on a sticker attached to the rear of main treadmill body (located on the right hand side of the treadmill base next to the mains power cord inlet).

General Safety Information

1. It is the responsibility of the owner to ensure that all users of this treadmill are adequately informed of all warnings and precautions.
2. Use the treadmill only as described in this manual.
3. Place on a level surface, clear safety area of at least 2000 mm in length and at least as wide as the treadmill shall be provided behind the equipment when in use. Do not place the treadmill on any surface that blocks air openings. To protect the floor or carpet from damage, place a mat under the treadmill.
4. When choosing a location for the treadmill make sure that the location and position permit access to a plug.
5. Keep the treadmill indoors, away from moisture and dust. Do not put the treadmill in a garage, outbuilding, covered patio, or near water.
6. Do not operate the treadmill where aerosol products are used or where oxygen is being administered.
7. Keep children under the age of 12 and pets away from the treadmill at all times.
8. The treadmill should not be used by persons weighing more than 100kgs.
9. Never allow more than one person on the treadmill at a time.
10. Wear appropriate exercise clothing when using the treadmill. Do not wear loose clothing that could become caught in the treadmill. Athletic support clothes are recommended for both men and women. Always wear athletic shoes. Never use the treadmill with bare feet, wearing only stockings, or in sandals.
11. When connecting the power cord, plug the power cord into a grounded circuit. When replacing the fuse, an ASTA approved BS 1362 type should be fitted to the fuse carrier, A13 amp fuse should be used, no other appliance should be on the same circuit.
12. Keep the power cord away from any heated surface.
13. Never move the running belt while the power is turned on. Do not operate the treadmill if the power cord or plug is damaged, or if the treadmill is not working properly.
14. Never start the treadmill when you are standing on the walking belt. Stand on the side rail, hold the handrails, start with low speed and then step on the unit. When comfortable increase the speed to one that you are comfortable with.
15. The treadmill is capable of high speed. Adjust the speed in small increments to avoid sudden jumps in speed.
16. The pulse sensor is not a medical device, various factors, including the user's movement, may affect the accuracy of the heart rate readings. The pulse sensor is intended only as exercise aid in determining heart rate trends in general. **WARNING!** Heart rate monitoring systems may be inaccurate. Over exercising may result in serious injury or death. If you feel faint stop exercising immediately.
17. Never leave the treadmill unattended while it is running. Always remove the safety key when the treadmill is not in use.
18. Always examine your treadmill before using to ensure all parts are in working order.
19. Never insert any object or body parts into any opening.
20. Inspect and tighten all parts of the treadmill regularly. (see maintenance page)
21. Always unplug the treadmill before cleaning and/or servicing. Service to your treadmill should only be performed by an authorized service representative, unless authorized and/or instructed by the manufacturer. Failure to follow these instructions will void the treadmill warranty.
22. This appliance is not intended for use by person (including children) with reduced physical, sensory or mental capabilities, or lack of experience and knowledge, unless they have been given supervision and instruction concerning use of the appliance by person responsible for their safety. Keep unsupervised children away from the equipment. Injuries to health may result from incorrect or excessive training.



Safety Information

PRO FITNESS

Important – Please read fully before assembly or using

To reduce the risk of serious injury, read the entire manual before you assemble or operate the Roger Black Platinum Treadmill, In particular, note the following safety precautions.

Assembly

- Keep children and animals away from the work area, small parts could cause choke if swallowed.
- Make sure you have enough space to layout the parts before starting.
- Assemble the item as close to its final position (in the same room) as possible.
- Position the equipment on a clear, level surface.
- Dispose of all packaging carefully and responsibly.

Using

- It is the responsibility of the owner to ensure that all users of this product are properly informed as to how to use this product safely.
- This product is intended for domestic use only.
Do not use in any commercial, rental, or institutional setting.
- Before using the equipment to exercise, always do stretching exercises to properly warm up.
- If the user experiences dizziness, nausea, chest pain, or other abnormal symptoms **stop the workout and seek immediate medical attention.**
- Only one person at a time should use the equipment.

- Keep hands away from all moving parts.
- Always wear appropriate workout clothing when exercising. **Do not** wear loose or baggy clothing, since it may get caught in the equipment. Wear athletic shoes to protect your feet while exercising.
- **Do not** place any sharp objects around the equipment.
- Disabled persons should not use the equipment without a qualified person or doctor in attendance.
- This product is suitable for user's weight of: **100kgs.**
- This product conforms to ISO 20957-1 and EN 957-6. Class (H) - Home Use - Class (C)
- This exercise product has been designed and manufactured to comply with the latest (BS EN 957) British and European Safety Standards.

Components - Parts

If you have damaged or missing parts, please call the **Customer Service: 0345 600 1714**
www.argos-support.co.uk/

Please check you have all parts listing below

Note: Some of the smaller components may be pre-fitted to larger components. Please check carefully before contacting Argos regarding any missing components.

Total mass of the product is 51 kg. Foot print of the product is 158 * 71.8 cm.

The free standing equipment shall be installed on a stable and leveled base.

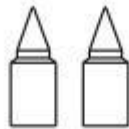

Lubricating Oil

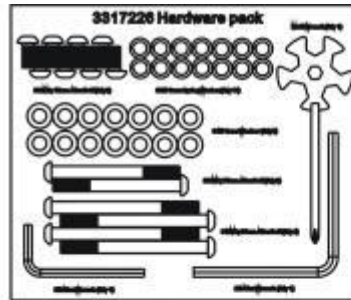

Hardware pack

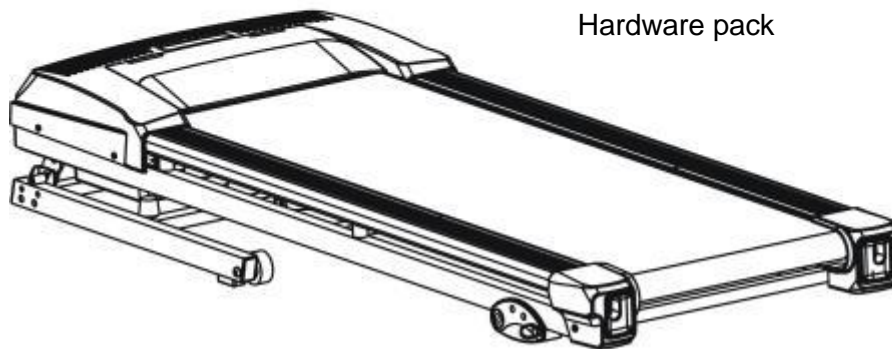

Main Frame

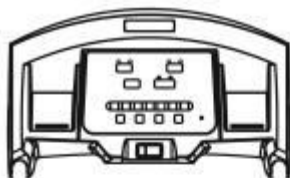

15. Console



52. Power cord



3. Left Console Mast

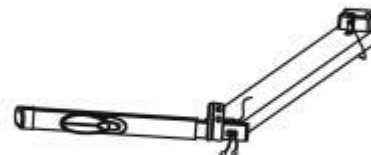

4. Right Console Mast



57. Mp3 Link



45. Safety Key

Components - Fixings

PRO FITNESS

Please check you have all parts listing below

Note: Some of the fixings are pre-fitted to the larger components. Please check carefully before contacting Argos regarding any missing fixings.

54



85mm Allen Bolt x 4

66



75mm Allen Bolt x 2

68



15mm Allen Bolt x 8

87



8mm Spring Washer x 14

84



8mm Washer x 14

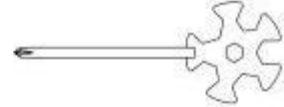

Multi Wrench x 1



5# Allen Wrench x 1



6# Allen Wrench x 1

Before Assembly

Overview Drawing

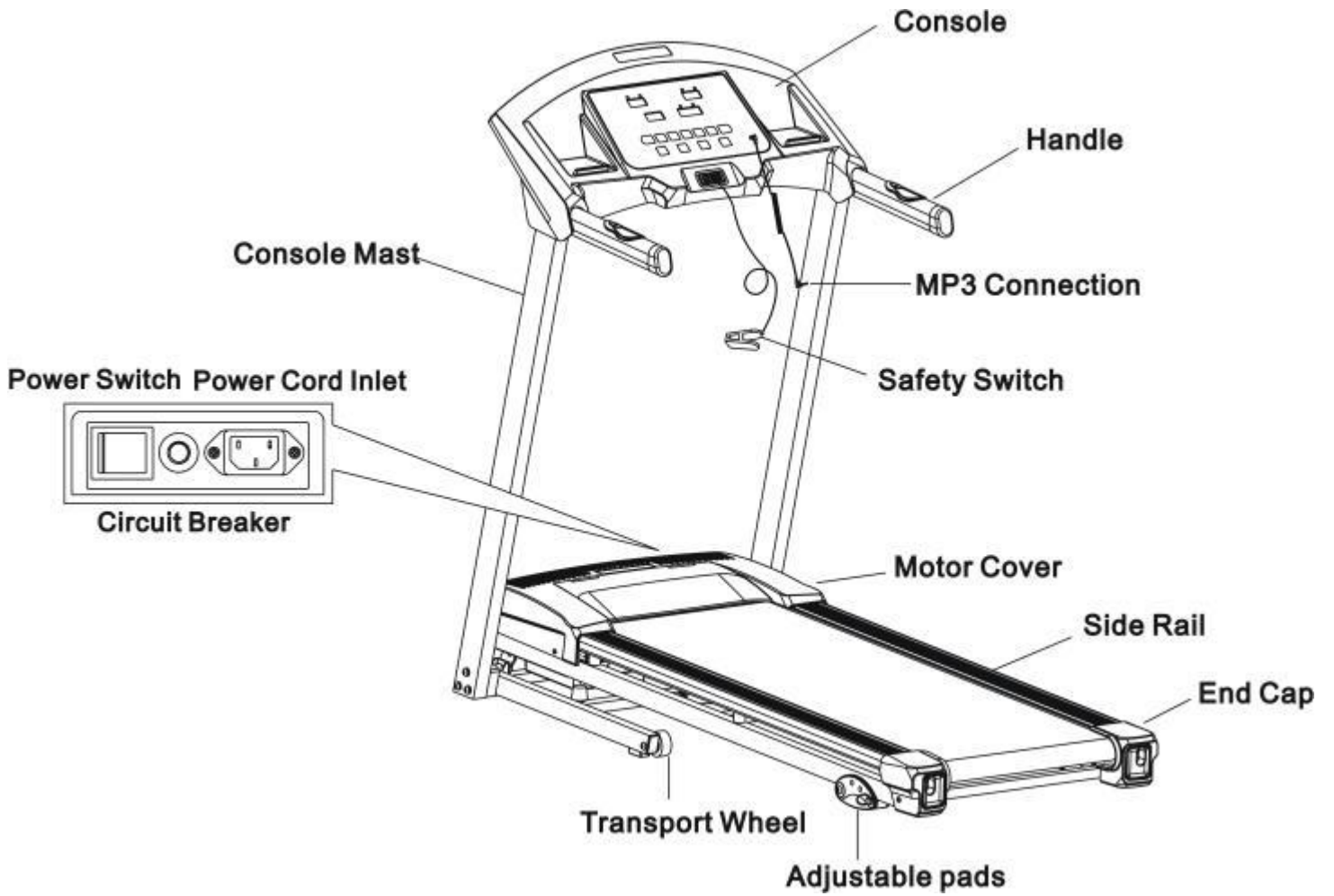

Assembly Instructions

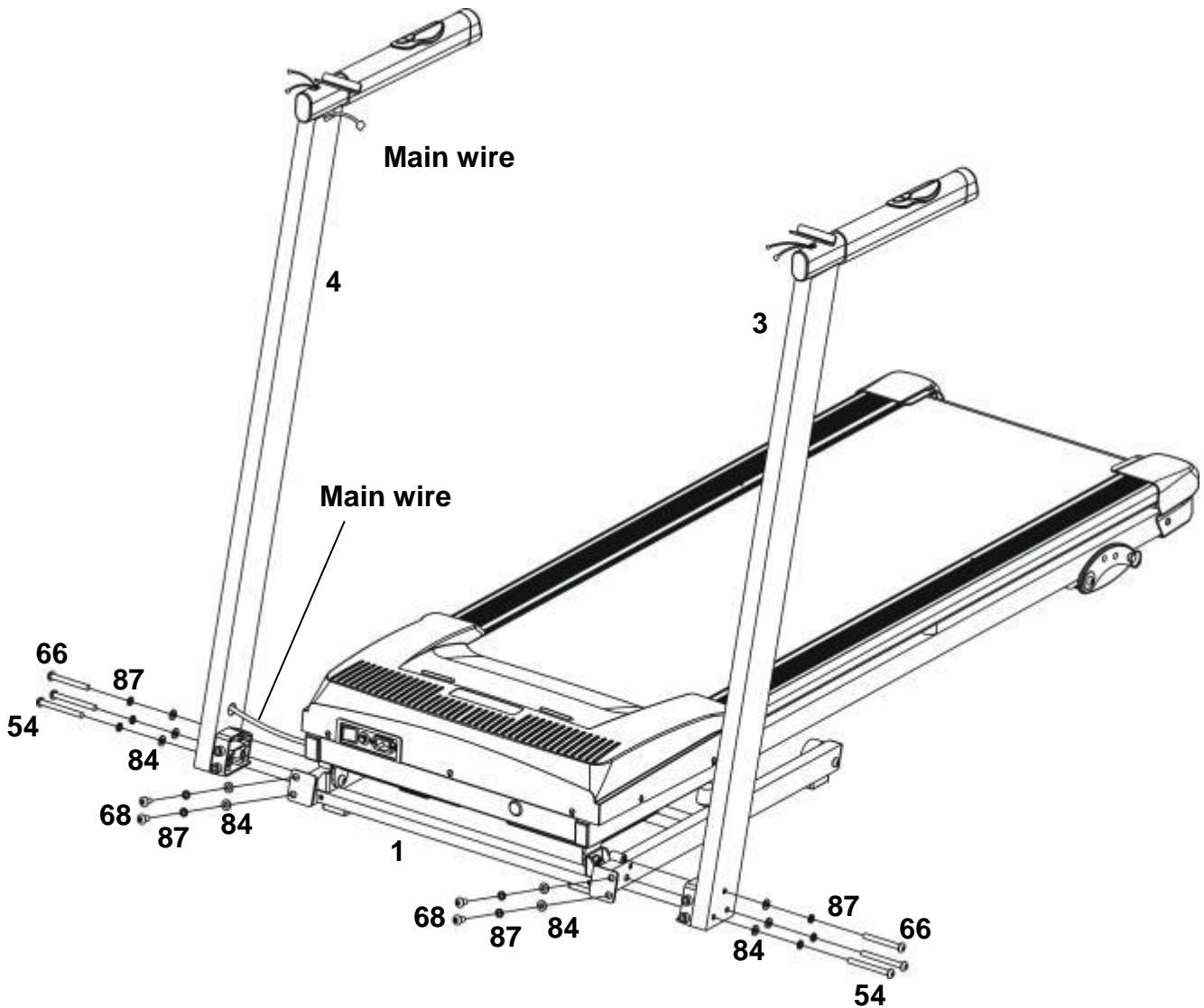
PRO FITNESS

Step 1

- Thread the Main wire from the bottom of the Console Mast (4) to the upper opening.
- Fix each Console Mast (3&4) to the Base Frame (1) using 2 x 75mm Allen Bolts (66), 4 x 85mm Allen Bolts (54), 4 x 15mm Allen Bolts (68), 10 x 8mm Spring Washers (87) and 10 x 8mm Washers (84).

Note: The above bolts can be fastened tightly. There should be a space of 2-3 mm left.

Assembly Instructions

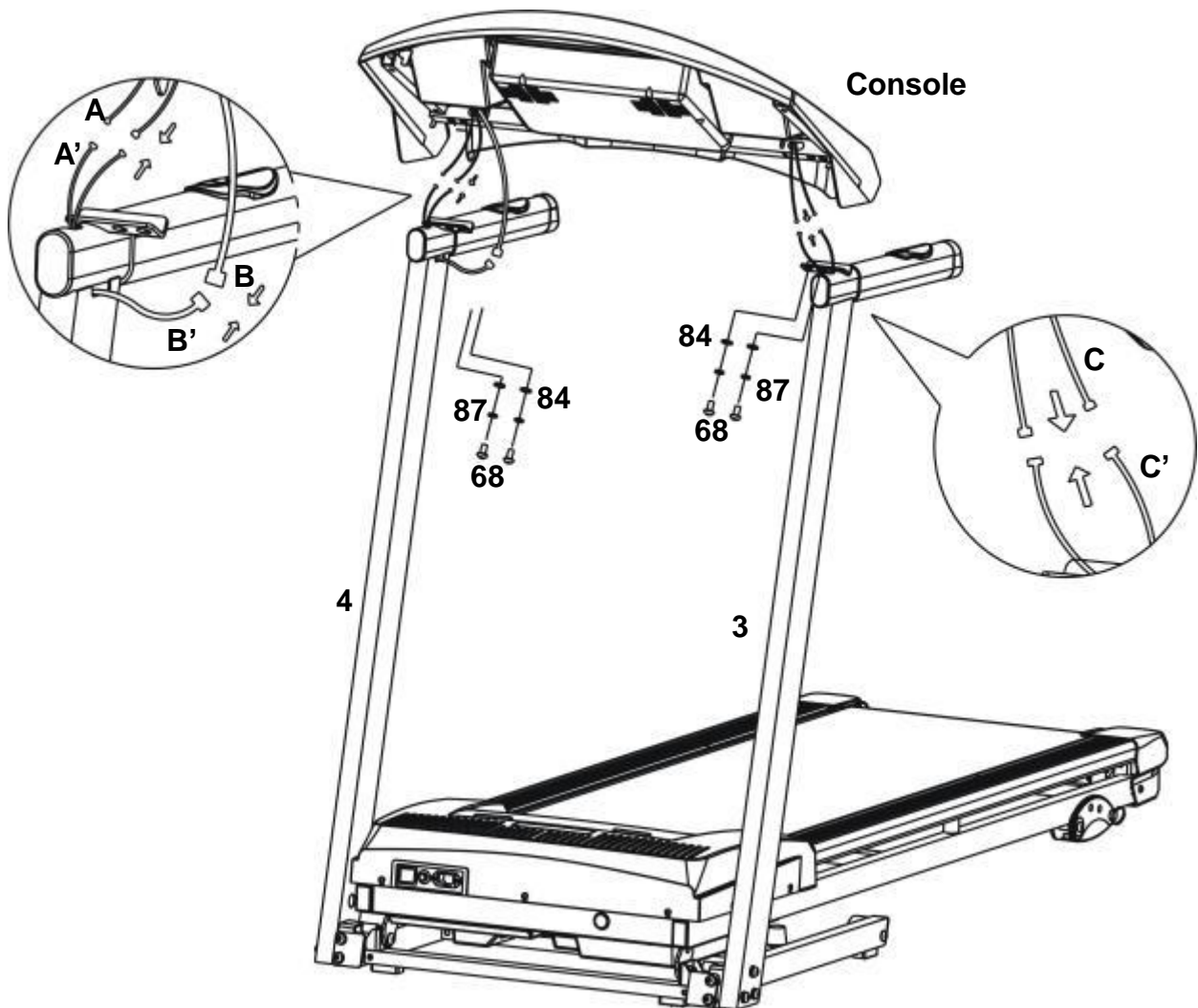

Step 2

a. Connect the wires as the diagram showing, insert the wires into the handles holes;

b. Fix each side of the Console to the two Console Mast (**3&4**) by using 4 x 15mm Allen Bolts (**68**), 4 x 8mm Spring Washes (**87**) and 4 x 8mm Washers (**84**).

Note: Fasten the bolts that are not fastened tightly in the first step and check whether or not there are fasteners which are not fastened yet.

Assembly Instructions

PRO FITNESS

Fold/Unfold the treadmill and adjust incline

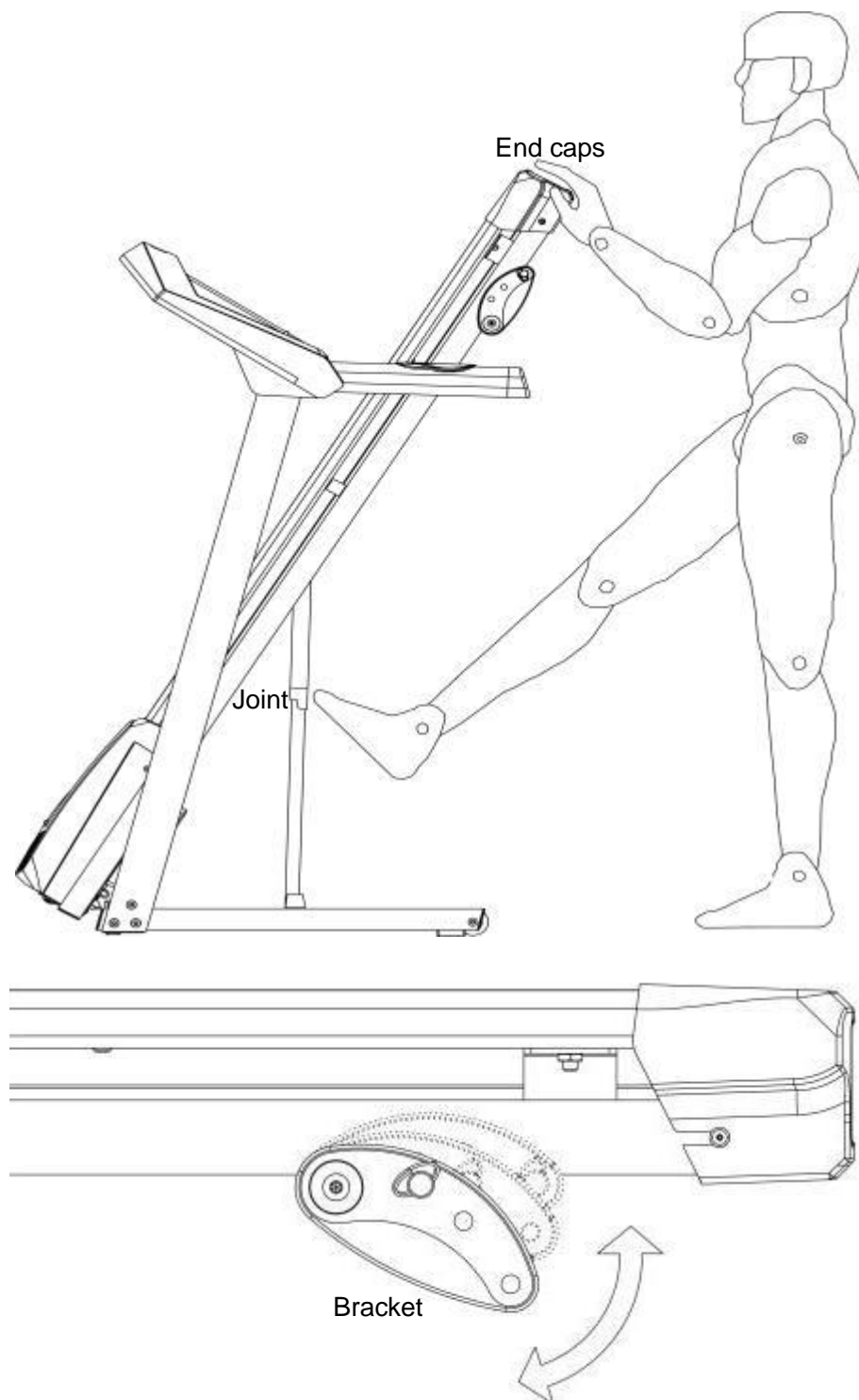

1. Hold the End caps to lift the running deck, make sure you hear the sound of the deck locking into position.
2. Hold the End caps, touch the joint with your tiptoes to unfold it.
3. The treadmill has three manual incline positions. Lift up the running deck as shown in Step 1. and adjust the Bracket to the desired incline and then return the running deck back to the floor.

Assembly Instructions

Free area and training area.

The free area shall be not less than 0.6m greater than the training area in the directions from which the equipment is accessed. The free area must also include the area for emergency dismount.

Where equipment is positioned adjacent to each other the value of the free area may be shared.

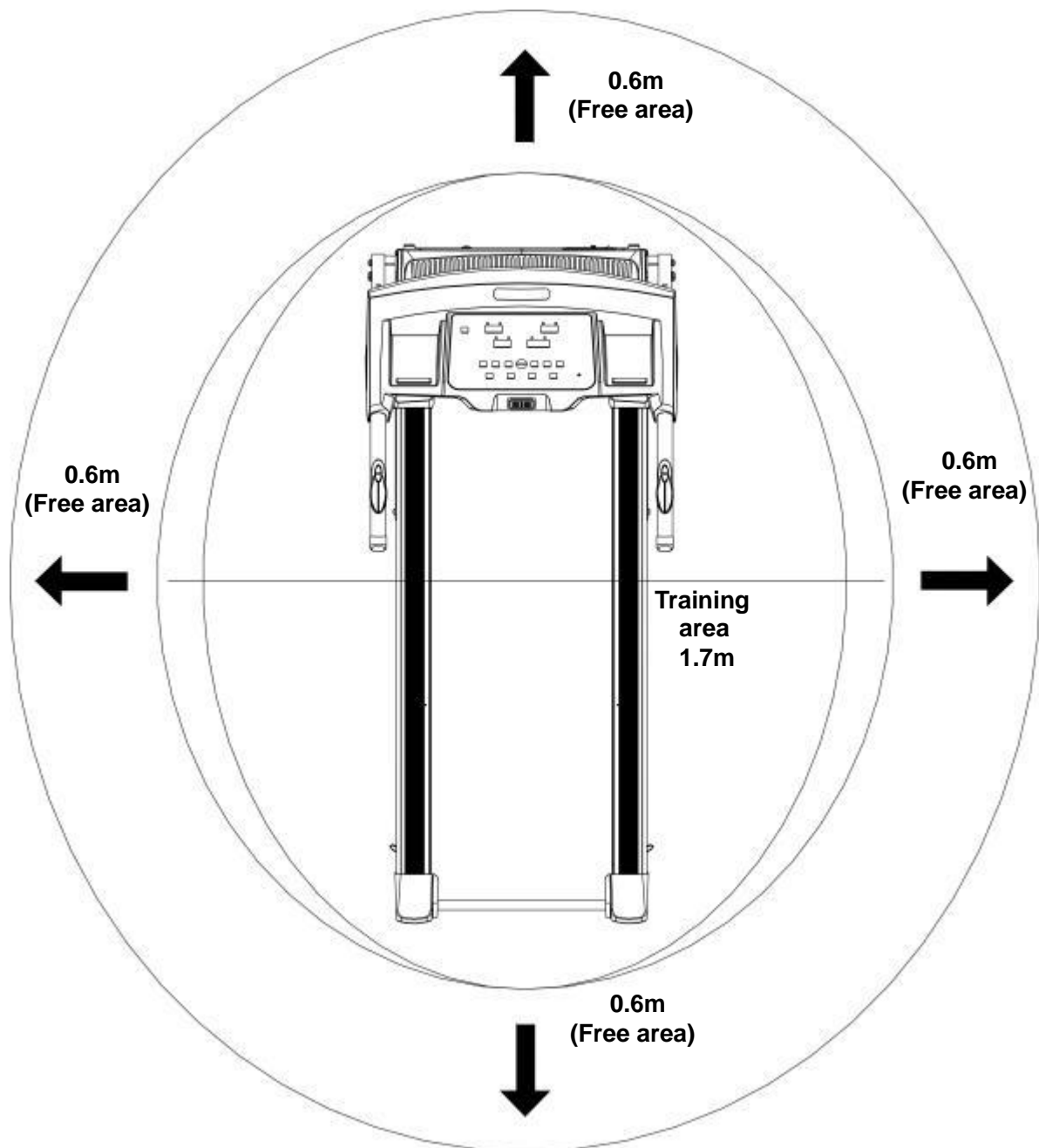

How to Start

Turning on the treadmill

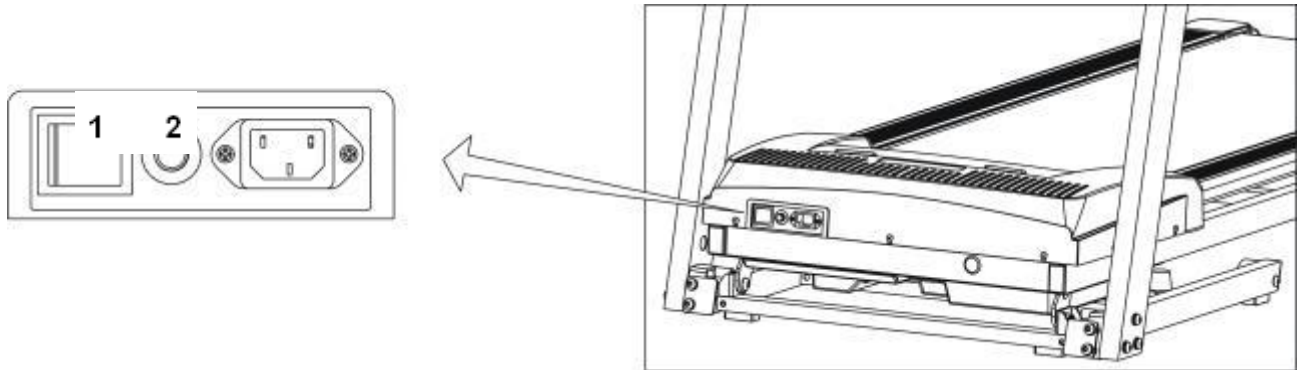

Plug in the mains power and turn on the switch (1).
You will hear a signal tone and the screen of the Computer will light up.

OVER-CURRENT PROTECTOR:

There is an over-current protector (2) located on the right side of the switch (1) (see above picture); in case of short circuit or over-current, the Button of the over current protector will pop up and the treadmill will power off; please unplug the power source and push down the button, and then turn on the switch to restart your workout. If the button pops up again, please contact Argos.

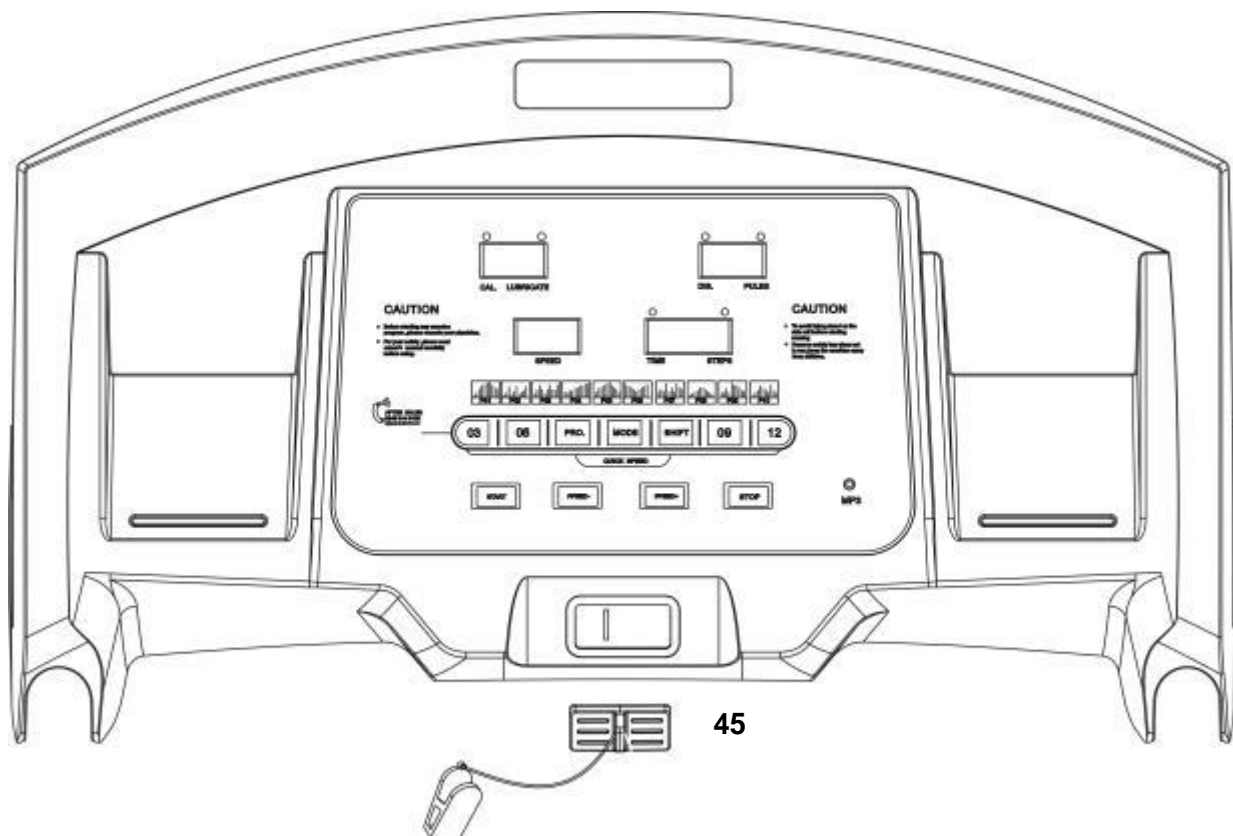

SAFETY KEY:

The treadmill will only work if the safety key (45) is properly locked in the provided notch of the console. Insert the safety key (45) and attach the clip onto the waist part of your clothes. If it is necessary to turn off the motor immediately, just pull the safety key (45) out of the console.

Computer Instruction

Front view of the Computer

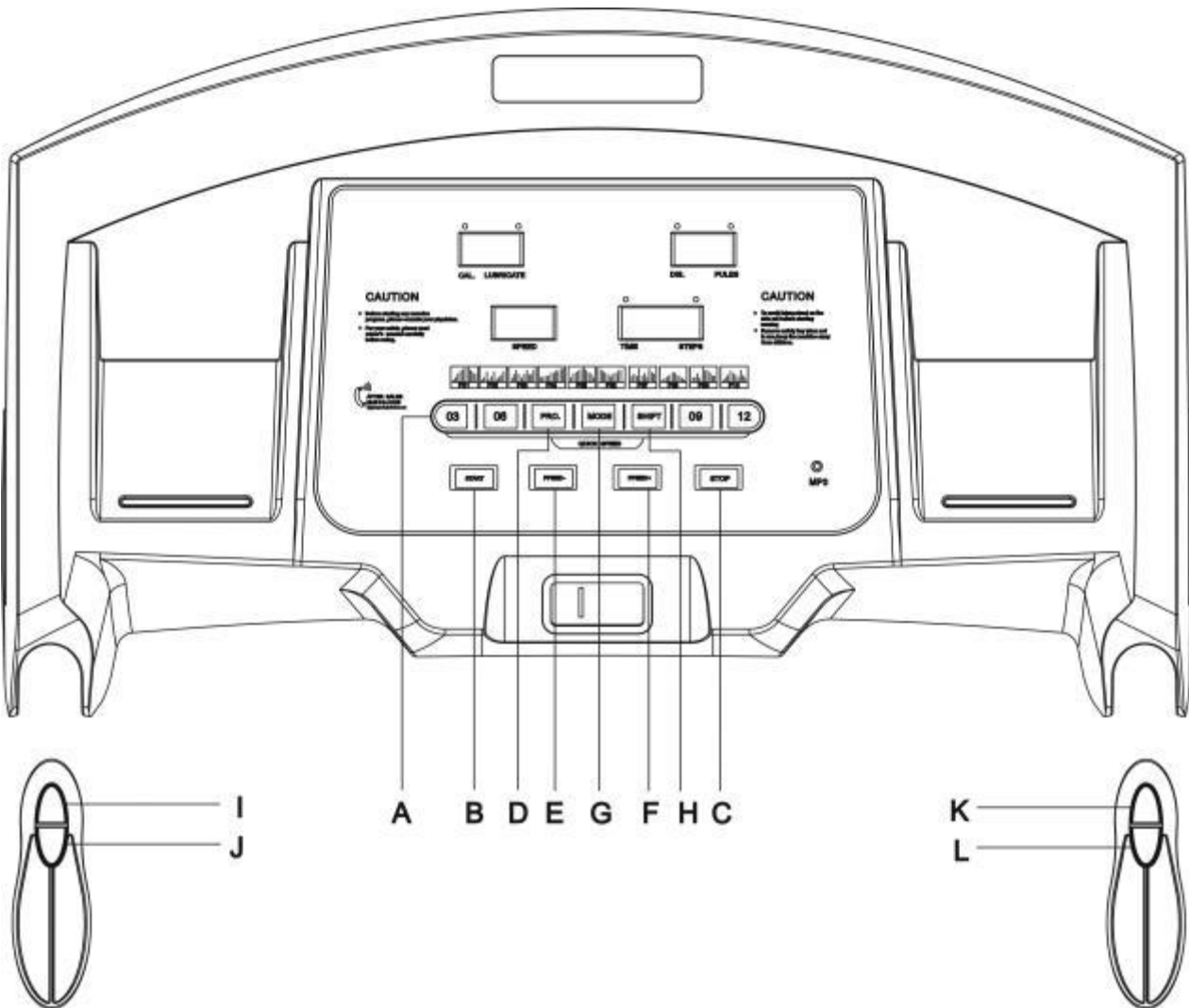

- A Quick Speed Select
- B Start
- C Stop
- D Program
- E Speed-
- F Speed+
- G Mode
- H Shift
- I Volume+
- J Volume-
- K Speed+
- L Speed-

Computer Operation

Functions and Operations

TECHNICAL SPECIFICATION

Time-----	0:00--99:59 Min
Speed-----	0.8--12.0 km/h
Distance-----	0.0--99.9 km
Calorie-----	0.0--999Kcal
Pulse-----	50--200 Times/ Min

Noise emission under load is higher than without load.

START

Press to start exercise at initial speed 0.8km/h

STOP

- Press during workout, and the treadmill will stop by gradually reducing the speed.
- Press again all display window will be cleaned to zero.

QUICK SPEED SELECT

Press to select your desired running speed with 3, 6, 9, 12km/h.

SPEED UP/DOWN

- Press to increase/decrease exercise speed by 0.1km/km
- Press to select training time under program workout model
- Press to choose the desired training target (Time, Distance, Calorie) under training target control workout model

PROGRAMME

Press to select workout program (P01—P10).

LUBRICATION REMINDERS

- After 100KM running, the console "LUBRICATE" window will flash to remind to lubricate the running belt.
- Press PROG key 3 seconds to turn off the flash when treadmill on standby.

LUBRICATION REMINDER

- After each 100KM running cycle, the console "OIL" window will flash to remind to lubricate the running belt.
- Pull up the Safety Key, press Prog/Mode key 5 seconds to cancel reminder.
- It will automatic cancel reminder after 1km running.
- Press "Speed+" and "Speed-" keys together to check the total distance in "Time" window.

PEDOMETER FUNCTION

- The "Time" and "Steps" alternate display in one window each 5s, you can lock "Time" or "Steps" by "Shift" key.

AUTOMATIC STOP FUNCTION

- The belt will stop automatically if no running 3 minutes.

Computer Operation

Functions and Operations

IMPORTANT

1. The console will turn off automatically about ten minutes after the belt has stopped.
2. The pulse function is for reference only, and not to be used for medical purpose.

SAFETY KEY

1. The safety key must be placed into the magnetic recess on the console in order to operate the treadmill. Always place the safety key on its position and attach the clip to your clothing at your waist before beginning your workout.
2. If you should encounter problems and need to stop the motor immediately, simply pull the safety key away from the console; to continue operation, simply turn the power switch to off, set the speed controller to stop and then reinsert the safety key into the console.

GENERAL OPERATION

1. Turn on the Power Switch at the front of your Treadmill. This switch is located next to the Mains Power Cord inlet.
2. Place the Safety Key into the magnetic recess on the middle front of the Computer Console.

The console will give an audible signal and all console window displays will function with a start display value of 0.

Note: If the Safety Key is not placed correctly or is faulty, the "Distance" window will display "E00", which indicates that the treadmill will not operate.

If the Safety Key falls off during exercise, the console will give an audible signal and "Distance" window will display "E00" and the treadmill will stop.

To stop the treadmill in an emergency, simply pull the safety key off its mount in the console front or simply press the red STOP button in the center of the console. It is important that you connect the clothing clip to your shirt or other suitable clothing during exercise to ensure that this safety system can operate easily.

To get a pre-exercise pulse rate, simply hold both Hand Pulse Sensors on either side of the Handlebar Supports for 5 seconds. The Pulse Range is between 50 ~ 200 Beats per Minute.

Note: The readings displayed by the computer should not be used for therapeutic purposes as they can vary due to the sensitivity of the equipment and the available pulse signal put out by individuals' palms. To get the best accurate readings, keep the hands placed flat and firm on the PULSE PADS for 10 to 20 seconds, as this will allow the pulse reading to average and then settle.

Functions and Operations

● STARTING YOUR TREADMILL

1. Turn on the treadmill, and press “Start” button on the console.
2. Press “Speed +” or “Speed -” button to adjust speed or press handle “Speed + or Speed -” button to adjust speed. Press the key once, and the speed changes 0.1Km/H.
3. Also the user can press the “Quick Speed Select” button to select desired running speed and incline.

● STOPPING YOUR TREADMILL

4. Press the “Speed -” button on the console, adjust or press handle “Speed -” button to reduce the speed, then press the “Stop” key on the Console, and the treadmill will stop; turn off the switch if you intend to finish workout.
5. Pull away the Safe Key and the treadmill will stop itself, and then “Distance” window will display “E00”.

● TRAINING TIME CONTROL WORKOUT MODE

1. Turn on the treadmill, press the “MODE” button one time, and the “Time” window flashes and displays “15:00”, which is the pre-set training time of the treadmill. Press “Speed +” / “Speed -” button to select your desired training time, (the range is 5:00—99:00).
2. Press “Start” button to start your workout, the time data will reduce gradually during your training and the treadmill will stop automatically when the “Time” window displays “0:00”.

● TRAINING DISTANCE CONTROL WORKOUT MODEL

1. Turn on the treadmill, press the “Mode” key two times, and the “Dis” (Distance) window flashes and displays “1.0”, which is the pre-set training distance of the treadmill.
2. Press “Speed +” / “Speed -” button to select your desired training distance (the range is 0.5—99.9).
3. Press “Start” button to start your workout, the time data will reduce gradually during your training and the treadmill will stop automatically when the “Dis” (Distance) window displays “0.0”.

● BURNING CALORIE CONTROL WORKOUT MODEL

4. Turn on the treadmill, press the “Mode” button three times continuously, the “Cal” (Calorie) window flashes and displays “50.0”, which is the pre-set burning calories of the treadmill. Press “Speed +” / “Speed -” button to select target burning calories (the range is 10.0---999).
5. Press “Start” button to start your workout, the calories data reduce gradually during your training, and the treadmill will stop automatically when the “Cal” (Calorie) window display “0.0”.

● SPEED AND INCLINE ADJUSTMENT

6. In any training target control workout model, press “Speed +” / “Speed -” button or press the “Quick Speed Select” button to choose your desired running speed.

Computer Operation

Functions and Operations

1. Program Workout Model (P01—P10)

In this mode, the user has a choice of Program P01 – Program P10.

2. Press the “Prog. ” button one time, the “Program” window will display “P01-P10” and the “Time” window will display “10:00”, which is the preset time of the treadmill for each program. Press “Speed +” / “Speed -” button to select your desired training time, (the range is 5:00—99:00).

4. For all preset values, please refer to following table and diagrams.

Any of the training program levels has 10 segments, and each segment time is 1/10 of total setting time; during any training segments, press the “Speed +” / “Speed -” button to adjust training speed.

Starting speed for each program

Program	Start Speed
P01	1.5Km/h
P02	3.0Km/h
P03	4.5Km/h
P04	3.0Km/h
P05	3.0Km/h
P06	7.5Km/h
P07	3.0Km/h
P08	1.5Km/h
P09	3.0Km/h
P10	1.5Km/h

3. Press “Start” button and the treadmill will countdown three and start operation. The start speed depends on the program you have chosen.

Computer Operation

PRO FITNESS

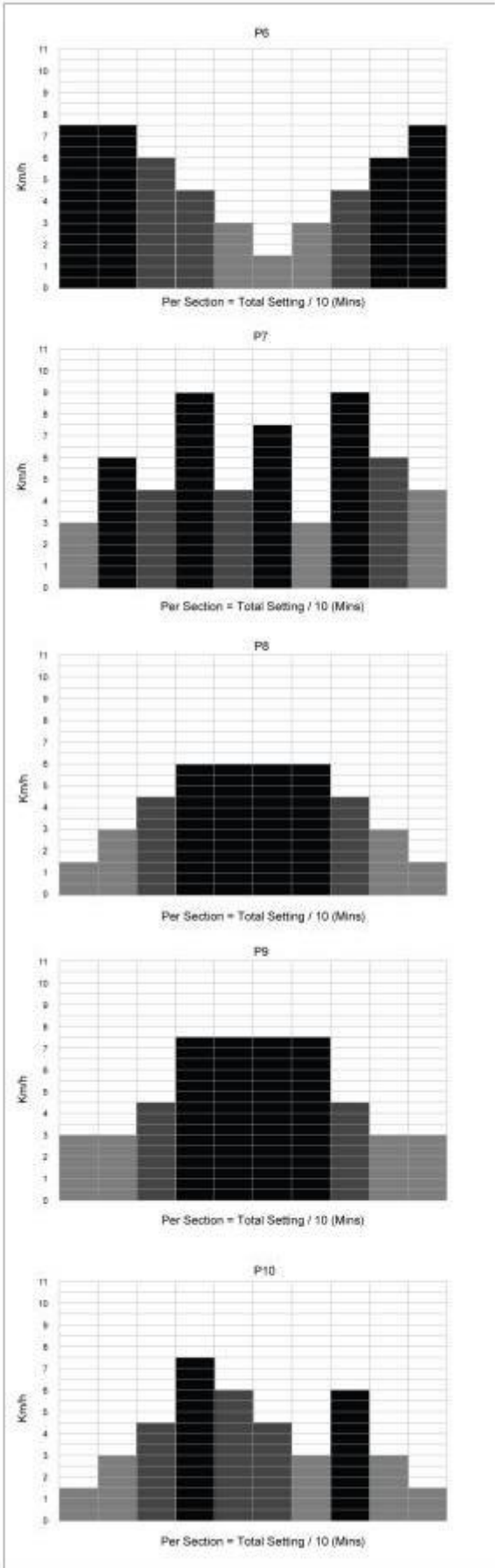
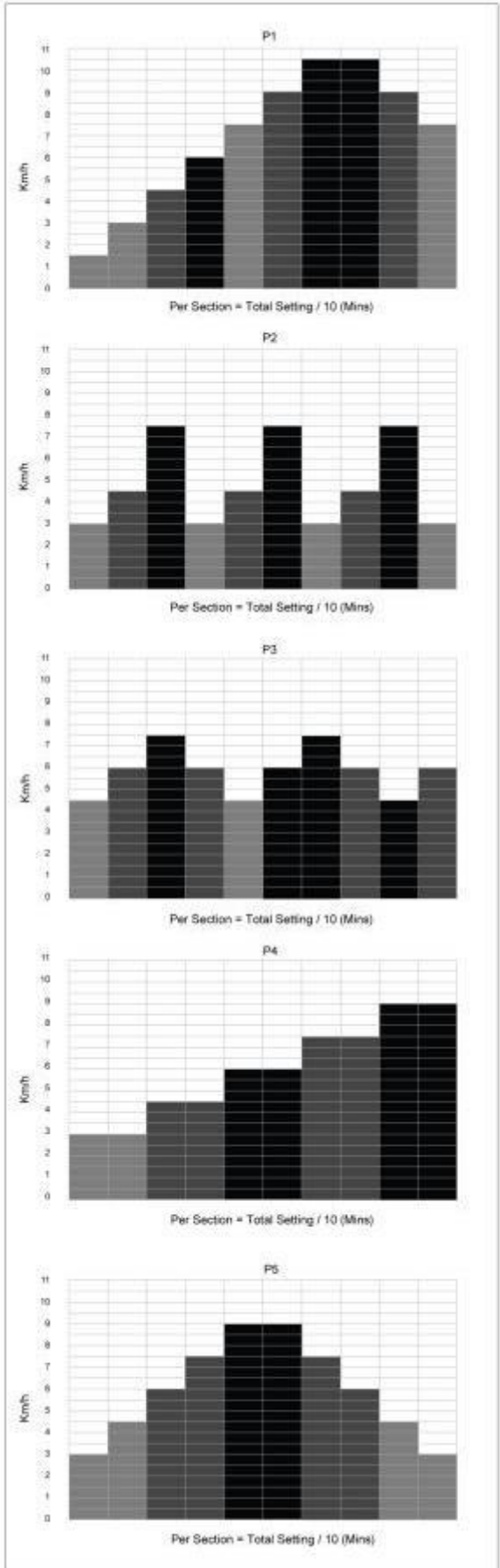

1. PULSE CONTROL WORKOUT MODE

- Turn on the treadmill, press “Prog.” button until the “Cal.” window display “HP1”. “Time” window displays “10:00” which is the treadmill pre set workout time for pulse control workout mode.
- Press “Speed +” or “Speed -” button to choose your desired training time.
- Press the “Mode” button, the “Speed” window is displaying “120” - which is the treadmill pre set pulse value (85-195). Press “Speed +” or “Speed -” button to choose your desire value.
- Press “Mode” key to enter your setting information when starting your workout, the treadmill will run with the speed 1.0km/h for about 1mins warm up, grasp the two handle pulse sensors with your two hands, then the treadmill will run automatically according to user’s heart beat rate, every 10 seconds increasing by 0.5Km/h. Once the treadmill speed is on 8Km/h, but the heart rate is lower than the setting data, then the treadmill will increase incline by 1% every 10 seconds to reach your setting heart rate.
- When your heart rate is over your setting heart rate, then the treadmill will decrease incline by 1% every 10 seconds, if user’s heart is still over your setting heart rate, then the treadmill will decrease running speed by 0.5Km/h until our heart rate is lower than your setting heart beat rate.
- The treadmill has three pulse control workout modes, press “Prog.” button to select “HP1” “HP2 “ or “HP3”.

Note: HP1 Pulse Control Workout Mode, the treadmill default Max running speed is 8Km/h, HP2 and HP3 Max running speed is 9/10Km/h. We recommend you to read target heart rate zone table on page 20 carefully before you starting Pulse Control Workout.

User's Target Heart Rate Table

AGE	Heart Beat (Times/Mins)			AGE	Heart Beat (Times/Mins)			AGE	Heart Beat (Times/Mins)		
	H	Default	L		H	Default	L		H	Default	L
15	195	123	123	37	174	110	110	59	153	97	97
16	194	122	122	38	173	109	109	60	152	96	96
17	193	122	122	39	172	109	109	61	151	95	95
18	192	121	121	40	171	108	108	62	150	95	95
19	191	121	121	41	170	107	107	63	149	94	94
20	190	120	120	42	169	107	107	64	148	94	94
21	189	119	119	43	168	106	106	65	147	93	93
22	188	119	119	44	167	106	106	66	146	92	92
23	187	118	118	45	166	105	105	67	145	92	92
24	186	118	118	46	165	104	104	68	144	91	91
25	185	117	117	47	164	103	103	69	143	91	91
26	184	116	116	48	163	103	103	70	143	90	90
27	183	116	116	49	162	103	103	71	142	90	89
28	182	115	115	50	162	102	102	72	141	90	89
29	181	115	115	51	161	101	101	73	140	90	88
30	181	114	114	52	160	101	101	74	139	90	88
31	180	113	113	53	159	100	100	75	138	90	87
32	179	113	113	54	158	100	100	76	137	90	86
33	178	112	112	55	157	99	99	77	136	90	86
34	177	112	112	56	156	98	98	78	135	90	85
35	176	111	111	57	155	98	98	79	134	90	85
36	175	110	110	58	154	97	97	80	133	90	84

BODY FAT ANALYSIS

- Turn on the treadmill, press “PROG” button, the “CAL.” window displays “FAT”.
- Press the “MODE” button again, the “DIS.” window is displaying “01”, the “CAL.” window displays “F-1”. Press “Speed +” or “Speed -” Key, then the “Speed” Window will change to “01” or “02”, Please select your sexual distinction, “01” – Male, “02” – Female.
- Press the “MODE” key again, the “DIS” window displays: “25” – Which is the treadmill preset user’s age, the “CAL.” window displays “F-2”. Press “Speed +” or “Speed -” button to select your correct age. (Range is: 10 – 99).
- Press the “MODE” button again, the “DIS” window displays “170” – Which is the treadmill preset user’s body height 170cm, the “CAL.” window displays “F-3”. Press “Speed +” or “Speed -” button to select your correct body height. (Range is: 100 – 200cm).
- Press the “MODE” button again, the “DIS” Window displays: “70”, Which is the treadmill preset user’s body weight 70kg, the “CAL.” window displays “F-4”. Press “Speed +” or “Speed -” button or press “Incline +” or “Incline -” key to select your correct body weight. (Range is: 20 – 100kg).
- Press “MODE” key again, the “CAL” window is displaying “F - 5” and the “DIS” window is displaying: “ --- “. Grasp the two handle pulse sensor with your two hands and hold for about 3 seconds, the “Pulse” window will display your desired body fat rate, refer to below table for your body fat date.

Body Fat Scale Parameter Table

Body Fat	≤ 18.5	Under Weight
Body Fat	$= (20—25)$	Ideal Weight
Body Fat	$= (25—29)$	Over Weight
Body Fat	≥ 30	Obesity

This product is warranted to be free from defects in workmanship and material, under normal use and service conditions, for a period (1) one years from the date of purchase. This warranty only applies to the original purchaser, and is limited to replacing or repairing. All repairs for which warranty claims are made must be pre-authorized by the manufacturer. This warranty does not apply to any product or damage to the product caused by or attributed to freight damage, abuse, misuse, improper or abnormal usage or repairs not provided by an authorized service center, products used for commercial or rental purpose, or products used as store display models. No other warranty beyond that specifically set from above is authorized.

The Manufacturer is not responsible or liable for indirect, special or consequential damages arising out of or in connection with the use of the product or damages with respect to any economic, property, revenues or profits, and enjoyment loss or use, costs of removal.
The warranty extended hereunder is in lieu of any

and all other warranties of merchantability or fitness for a particular purpose is limited in its scope and duration to the terms set forth within.

This warranty gives your specific legal rights.

HOW TO ORDER REPLACEMENT PARTS

If you encounter any problem with the product, or need to order replacement parts, call UK **Customer Service: 0345 600 1714** or visit **www.argos-support.co.uk/**. To help us assist you, please be prepared to give us the following information:

The Model Number of the product (3317226).
The name of the product (Pro Fitness Treadmill)
The Serial Number/Manufacturing Date of the product/the description of the part(s), the purchase date and order number also required.

Belt Adjustment

Proper maintenance is very important to ensure a faultless and operational condition of the treadmill. Improper maintenance can cause damage to the treadmill or shorten the life of the product and exceed the LIMITED WARRANTY coverage.

- **Important:** Never use abrasives or solvents to clean the treadmill. To prevent damage to the computer, keep liquids away and keep it out of direct sunlight.
- All parts of the treadmill must be checked and tightened regularly. Worn out parts must be replaced immediately.

BELT ADJUSTMENT

You may need to adjust the running belt during the first few weeks of use. All running belts are properly set at the factory. It may stretch off the center after use. Stretching is normal during the break-in period.

ADJUSTING THE BELT TENSION

If the running belt feels as though it is “slipping” or hesitating when you plant your foot during a run, the tension on the running belt may have to be increased.

TO INCREASE THE RUNNING BELT TENSION

STEP 1: Place 6# Allen wrench on the left belt tension bolt. Turn the wrench clockwise 1/4 turn to draw the rear roller and increase the belt tension.

STEP 2: Repeat STEP 1 for the right belt tension bolt. You must be sure to turn both bolts the same number of turns, so the rear roller will stay square relative to the frame.

- Repeat STEP 1 and STEP 2 until the slipping is eliminated.
- Be careful not to tighten the running belt tension too much as you can create excessive pressure on the front and rear roller bearings. An excessively tightened running belt may damage the roller bearings that would result in bearing noise from the front and rear rollers.

TO DECREASE THE TENSION ON THE RUNNING BELT, TURN BOTH BOLTS COUNTER-CLOCKWISE THE SAME NUMBER OF TURNS.

CENTERING THE RUNNING BELT

When you run, you may push off harder with one foot than with the other. The severity of the deflection depends on the amount of force that one foot exerts in the relation to the other. This deflection can cause the belt to move off-center. This deflection is normal and the running belt will center when nobody is on the running belt. If the running belt remains consistently off-center, you will need to center the running belt manually.

Centering the Running Belt

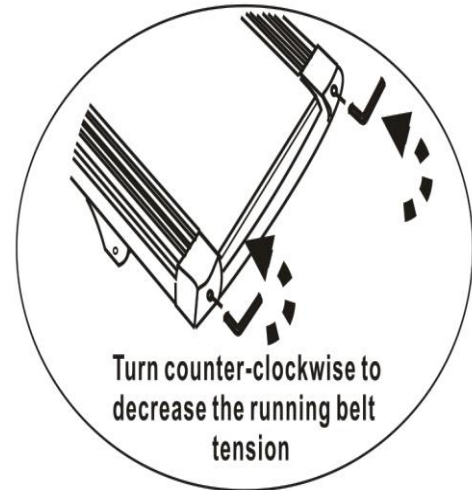
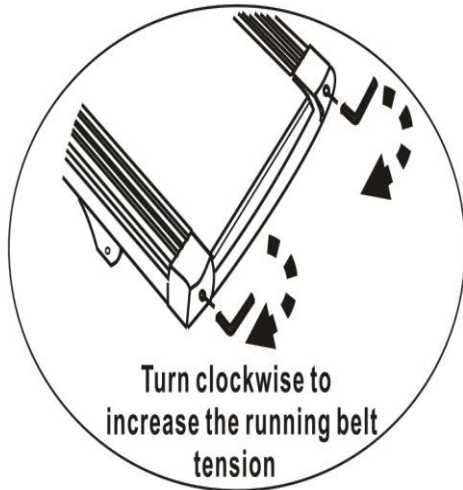

1. Start the treadmill without anyone on the running belt, press "Speed+" button until speed reaches 6Km/h.
2. Observe whether the running belt is toward the right or left side of the deck.
 - a) If toward the left side of the deck, using 6# Allen Wrench, turn the left adjustment bolt clockwise 1/4 turn and let the running belt will find its new position; if it's still moving toward left side, turn the bolt further for 1/4 turn.
 - b) If toward the right side of the deck, using 6# Allen Wrench, turn the right adjustment bolt clockwise 1/4 turn and let the running belt will find its new position; if it's still moving toward right side, turn the bolt further for 1/4 turn.
 - c) If the belt is still not center, repeat the above steps until the running belt is centered.
3. After the belt is centered, increase the speed to 12km/h and verify that it is running smoothly. Repeat the above steps if it is necessary. If the above procedure is unsuccessful in resolving the off-center, you may need to increase the belt tension.

Motor Belt Tension Adjustment

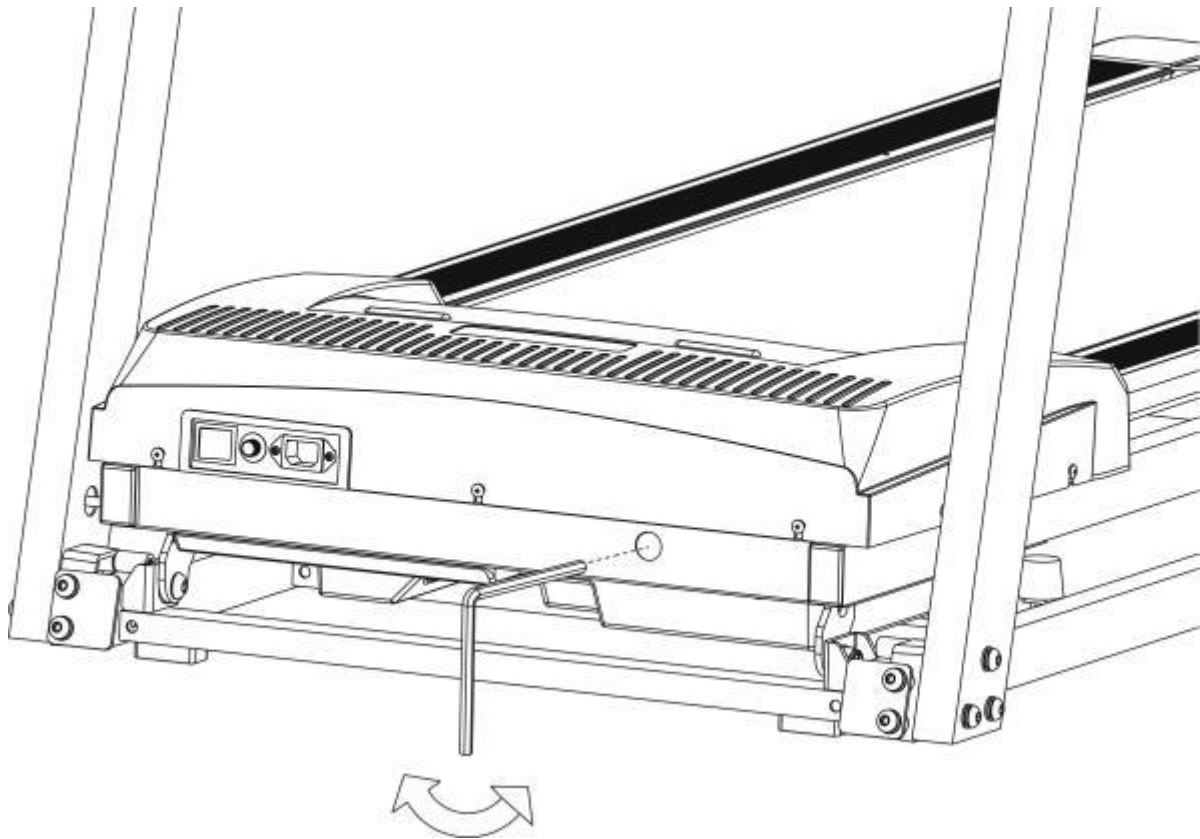

During your workout, if you find the running belt is not running smoothly, that means the motor belt is loose, please follow the below steps to adjust the motor belt tension:

1. Turn the motor belt adjustment bolt using an M8 Allen wrench 1/4 turn in clockwise direction.
2. Re-Start the treadmill and run on the treadmill; if the running belt is still not working properly, repeat above step.
3. Please do not make the motor belt too tight; if the belt is over tightened, it will cause the treadmill over loading and reduce the motor life.

Deck Lubrication

The treadmill is pre-lubricated. However, it is recommended to check the lubrication of the treadmill regularly, to ensure an optimal operation of the treadmill.

After every 2 months of operation, lift the sides of the treadmill and feel the surface of the belt, as far as possible. If traces of silicon spray are found, lubrication is not necessary. In case of a dry surface, refer to the instructions below.

Only use 100% silicon oil to lubricate your treadmill deck.

To apply lubricant on the belt

- Position the belt so that the seam is located in the middle of the plate.
- Lift the belt at one side and hold the spray valve at a distance of approximately 15cm to the front end of belt and plate. Then spray from front to the end. Repeat this process on the other side of the belt. Spray each side for about 4 seconds.
- Wait 1 minute to let the silicon spray spread, before starting the machine.

CLEANING

Regular cleaning of the belt ensures a long product life.

- **Warning:** The treadmill must be turned off to avoid electric shocks. The power cord must be pulled out of the socket, before starting the cleaning or maintenance.
- **Caution:** Do not use any abrasives or solvents. To avoid damage to the computer, keep any liquids away. Do not expose the computer to direct sunlight.
- **After each training:** Wipe the console and other surfaces with a clean soft and damp cloth to remove sweat residues.
- **Weekly:** To make cleaning easier, it is recommended to use a mat under the treadmill. Shoes can leave dirt on the belt that can fall beneath the treadmill. Clean the mat under the treadmill once a week.

STORAGE

Store your treadmill in a clean and dry environment. Ensure the master power switch is off and is un-plugged from the electrical wall outlet.

E00	Safety Key not in the position	Re-locate the safety key in the correct position
E01	No signal to Controller from console	A: Check the Main Controller Wire B: Replace the PCB Board
E02	Motor communication error	A: Check the wire from motor to controller B: IGBT breakdown, Replace the controller C: Check the power voltage if 50% lower than rate voltage D: replace the motor wire or change motor
E04	Incline Motor communication error	A: Check the wire from incline motor to controller B: Replace the incline motor C: Replace the controller
E05	Over current protector	A: Over loading or over resistance, restart the treadmill B: Transmission parts seized up, check the parts C: Replace controller D: Motor breakdown, change the motor
E06	Motor Open Circuit	Connect the Motor link
E08	IC Driver Error	Replace the IC driver or change the IC driver
E09	Folding up protect	A: Do not fold up the running deck when treadmill in is running B: If the running deck in laying position and show E09, you need change the controller
E10	Motor instantaneous current abnormal	A: Adjust the torsion potentiometer of the Controller to lower B: Motor Breakdown, change the motor
E11	Over voltage protector	Voltage over 270v (for 220v) or 150v (for 110v) -- turn off the treadmill and check the power source
E13	No signal to console from Controller	A: Check the Main Controller Wire B: Change the controller
E14	Lower voltage protector	Voltage lower than 160v (220v) or 70v (110v) -- turn off the treadmill and check the power source

How you begin your exercise program depends on your physical condition. If you have been inactive for several years, or are severely overweight, you must start slowly and increase your time on the equipment; a few minutes per workout.

Initially, you may be able to exercise only for a few minutes in your target zone, however, your aerobic fitness will improve over the next six to eight weeks. Don't be discouraged if it takes longer. It's important to work at your own pace. Ultimately, you'll be able to exercise continuously for 30 minutes. The better your aerobic fitness, the harder you will have to work to stay in your target zone.

Please remember these essentials:

- Have your doctor review your training and diet programs to advise you of a workout routine you should adopt.
- Begin your training program slowly with realistic goals that have been set by you and your doctor.
- Monitor your pulse frequently. Establish your target heart rate based on your age and condition.
- Set up your equipment on a flat even surface at least 3 feet from walls and furniture.

Exercise intensity

To maximize the benefits of exercising, it is important to exercise with the proper intensity. The proper intensity level can be found by using your heart rate as a guide. For effective aerobic exercise, your heart rate should be maintained at a level between 65% and 85% of your maximum heart rate as you exercise. This is known as your target zone. You can find your target zone in the table below.

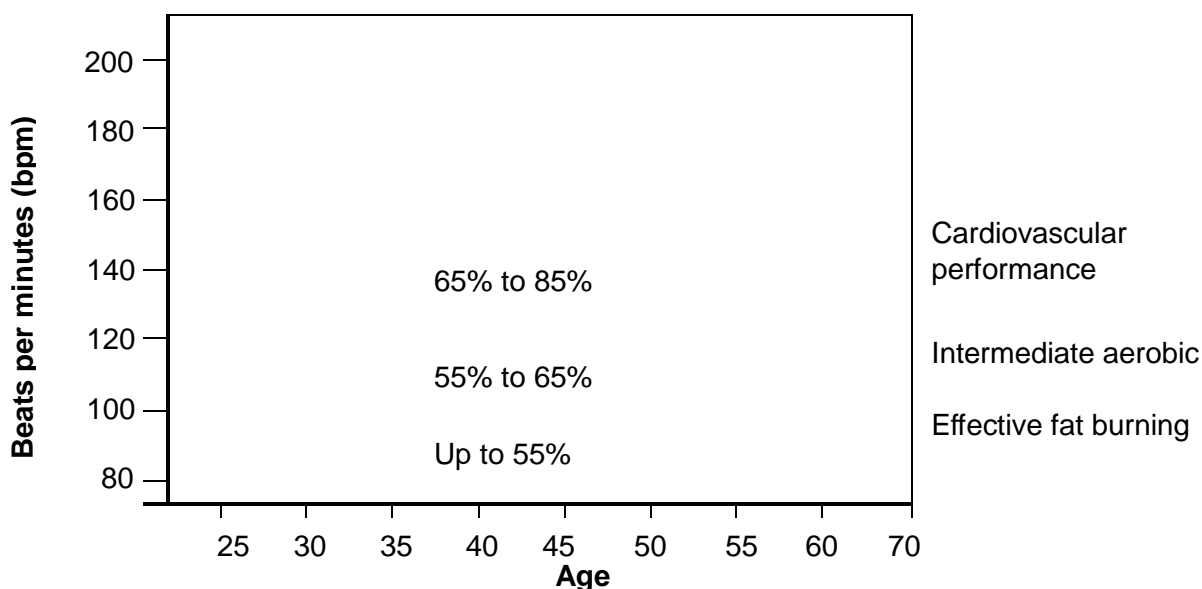

During the first few months of your exercise program, keep your heart rate near the low end of your target zone as you exercise. After a few months, your heart rate can be increased gradually until it is near the middle of your target zone as you exercise.

To measure your heart rate, stop exercising but continue moving your legs or walking around and place two fingers on your wrist. Take a six-second heartbeat count and multiply the results by 10 to find your heart rate. For example, if your six-second heartbeat count is 14, your heart rate is 140 beats per minute. (A six-second count is used because your heart rate will drop rapidly when you stop exercising.) Adjust the intensity of your exercise until your heart rate is at the proper level.

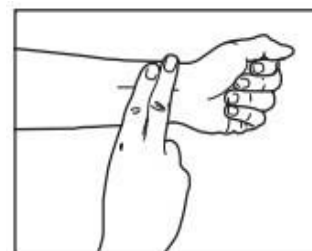

Aerobic Exercise

Aerobic exercise improves the fitness of your lungs and heart - your body's most important muscle. Aerobic exercise fitness is promoted by any activity that uses your large muscles (arms, legs, or buttock, for example). Your heart beats quickly and you breathe deeply. An aerobic exercise should be part of your entire exercise routine.

Weight Training

Along with aerobic exercising which helps get rid of and keep off the excess fat that our bodies can store, weight training is an essential part of the exercise routine process. Weight training helps tone, build and strengthen muscle. If you are working above your target zone, you may want to do a lesser amount of reps. As always, consult your doctor before beginning any exercise program.

Targeted Muscle Groups

The exercise routine that is performed on the Treadmill will develop the upper and lower body muscle groups. These muscle groups are highlighted on the muscle chart below.

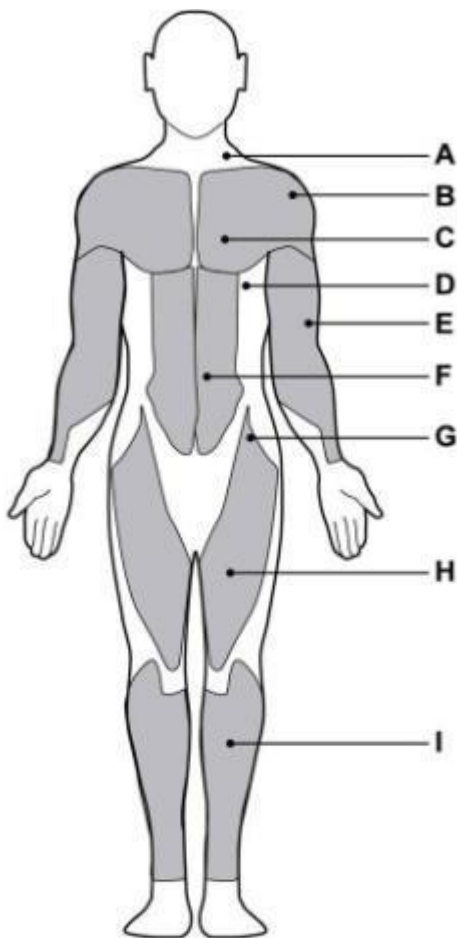

Front

- | | |
|-----------------------------|----------------------|
| A: Trapezius | F: Abdominal |
| B: Anterior | G: Sartorius |
| C: Pectoralis Major | H: Quadriceps |
| D: Serratus Anterior | I: Tibialis |
| E: Biceps | |

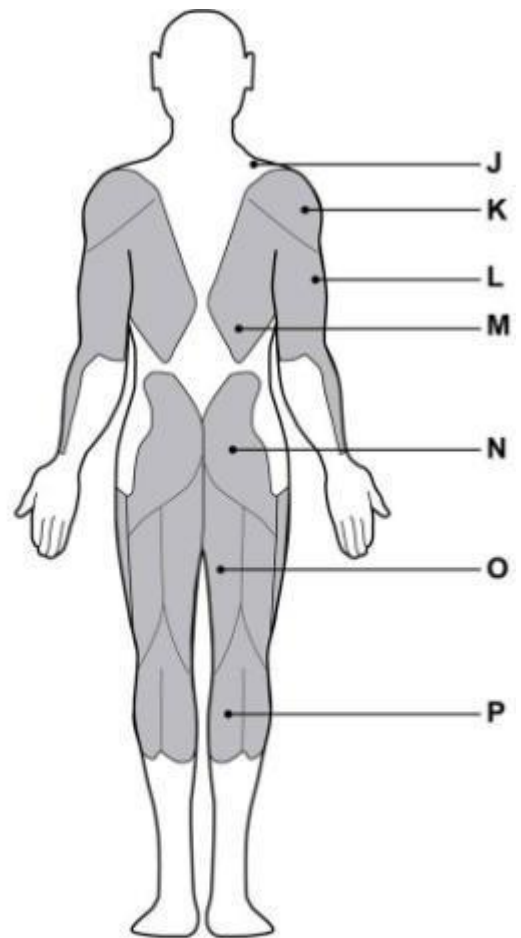

Back

- | | |
|----------------------------|-------------------------|
| J: Trapezius | N: Gluteals |
| K: Posterior | O: Hamstrings |
| L: Triceps | P: Gastrocnemius |
| M: Latissimus Dorsi | |

Each workout should include the following three parts:

1. A warm up, consisting of 5 to 10 minutes of stretching and light exercise. A proper warm up increases preparation for exercise.
2. Training zone exercise consisting of 20 to 30 minutes of exercising with your heart rate in your training zone. (**Note:** During the first few weeks of your exercise programmer, do not keep your heart rate in your training zone for longer than 20 minutes.)
3. A cool down, with 5 to 10 minutes of stretching. This will increase the flexibility of your muscles and will help to prevent post-exercise problems.

Exercise Frequency

To maintain or improve your condition, plan three workouts each week with at least one day of rest between workouts. After a few months of regular exercise, you may complete up to five workouts each week, if desired. Remember, the key to success is to make exercise a regular and enjoyable part of your everyday life.

Toe touch stretch

Stand with your knees bent slightly and slowly bend forward from your hips. Allow

reach down toward your toes as far as possible.

Hold 15 counts, and then relax.

Repeat 3 times.

Stretches: Hamstrings, back of knees and back.

Hamstring stretch

Sit with one leg extended. Bring the sole of the opposite foot toward you and rest it against the inner thigh of your extended leg. Reach toward your toes as far as possible.

Hold for 15 counts, and then relax.

Repeat 3 times for each leg.

Stretches: Hamstrings, lower back and groin.



With one leg in front of the other, reach forward and place your hands against a wall. Keep your back leg straight and your back foot flat on the floor. Bend your front leg, lean forward and move your hips toward the wall.

Hold for 15 counts, and then relax.

Repeat 3 times for each leg. To cause further stretching of the Achilles tendons, bend your back leg as well.

Stretches: Calves, Achilles Tendons and Ankles.

Quadriceps stretch

With one hand against the wall for balance, reach back and grasp one foot with your other hand. Keeping your bent knee pointing directly downward towards the floor, gently pull your heel towards your buttock until you feel a gentle stretch in the target area.

Hold for 15 counts, and then relax.

Repeat 3 times for each leg.

Stretches: Quadriceps and Hip muscles.

Inner thigh stretch

Sit with the soles of your feet together and your knees outward. Pull your feet toward your groin area as far as possible.

Hold for 15 counts, and then relax.

Repeat 3 times.

Stretches: Quadriceps and Hip muscles.

1. Examine the equipment periodically in order to detect any damage or wear which may have been produced. The safety level of the equipment can be maintained only if it is examined regularly for damage and wear, e.g. belt, connection points.
2. Lubricate moving parts with light oil periodically to prevent premature wear.
3. Replace defective components immediately and/or keep the equipment out of use until repair. Special attention to components most susceptible to wear.
4. The equipment can be cleaned using a damp cloth and mild non-abrasive detergent. **Do not** use solvents.
5. **Do not** attempt to repair this equipment yourself. Should

you have any difficulty with assembly, operation or use of your exercise product or if you think that you may have parts missing, contact the manufacturer, their approved service agent or the **Customer Service: 0345 600 1714.**
www.argos-support.co.uk/

Guarantee:
For guarantee purposes, please retain your purchase receipt.

Exploded Parts Diagram

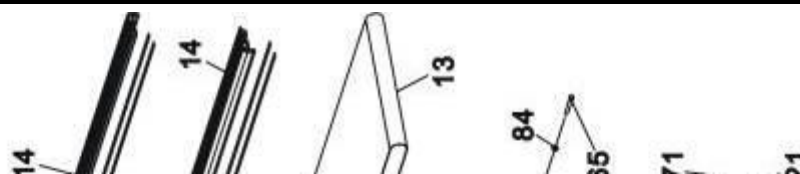

Key No.	Description	QTY	Key No.	Description	QTY
1	Base frame	1	28	End Cap	2
2	Running stage	1	29	10mm×1mm EVA	4
3	Left console mast	1	30	φ 40× φ 10×2mm Washer	2
4	Right console mast	1	31	Flinger	3
5	Console frame	1	32	Switch box	1
6	M8 Aircraft nut	4	33	190J Motor belt	1
7	Front roller	1	34	End cap	2
8	Rear roller	1	35	Cushion	4
9	Motor support	1	36	Handle grip	2
10	Adjustable bracket	2	37	Rubber Cushion	1
11	Protective pipe	2	38	End cap	1
12	Running deck	1	39	End cap	2
13	2580×420×1.6mm Running belt	1	40	Cushion	1
14	Side rail	2	41	Shock pad	4
15	Console housing	1	42	Roller	2
16	Safety key cover	1	43	Pulse sensor	2
17	Display screen	1	44	Motor	1
18	Logo sticker	4	45	Safety key	1
19	Motor cover	1	46	Controller	1
20	Left mast cover Sticker	1	47	Inductor	1
21	Right mast cover sticker	1	48	Filter	1
22	Left end cap	1	49	Switch	1
23	Right end cap	1	50	Over current Protector	1
24	Motor bottom cover	1	51	Power Socket	1
25	End cap	2	52	Power cord	1
26	Pin	2	53	Short cords (Connectors of 47/48/49)	1
27	End Cap	2	54	M8×85mm Allen bolt	4

Key No.	Description	QTY	Key No.	Description	QTY
55	PC Board	1	77	ST2.9x10mm Dome Head Philips Screw	2
56	Amplifier module	1	78	M3x12mm Philips Screw	2
57	MP3 Link	1	79	M4x10mm Philips Screw	1
58	Speaker	2	80	M10 Aircraft Nut	2
59	Sticker	1	81	M8 Aircraft Nut	6
60	Air spring	1	82	M3 Hex Nut	2
61	Φ25xΦ15x5mm Washer	8	83	Φ10mm Washer	6
62	M8x24mm Philips Screw	6	84	Φ8mm Washer	20
63	M10x25mm Philips Screw	2	85	Φ3mm Washer	2
64	M10x20mm Philips Screw	4	86	Φ10mm Spring Washer	4
65	M8x60mm Allen Bolt	4	87	Φ8mm Spring Washer	16
66	M8x75mm Allen Bolt	2	88	Φ3mm Spring Washer	2
67	M8x30mm Allen Bolt	1	89	Φ4mm Washer	1
68	M8x15mm Allen Bolt	8	90	Φ4mm Spring Washer	1
69	M8x45mm Allen Bolt	1	91	M8x15mm Allen bolt	2
70	ST4.8x15mm Philips Screw	16	92	MP3 Module	1
71	ST4.8x15mm Dome Head Philips Screw	13	93	PCB Module	1
72	ST4.2x50mm Dome Head Philips Screw	2	94	ST4.8x12mm Dome Head Philips Screw	11
73	ST4.2x25mm Dome Head Philips Screw	2	95	Safety key plug	1
74	ST4.2x15mm Dome Head Philips Screw	19	96	Main wire (Console-MCB cables)	1
75	ST2.9x8mm Dome Head Philips Screw	29	97	M8x45mm Allen Bolt	2
76	ST4.2x12mm Dome Head Philips Screw	4			



Product Guarantee

This product is guaranteed against manufacturing defects from a period of



Year

This product is guaranteed for twelve months from the date of original purchase. Any defect that arises due to faulty materials or workmanship will either be replaced, refunded or repaired free of charge where possible during this period by the dealer from whom you purchased the unit.

The guarantee is subject to the following provisions:

- The guarantee does not cover accidental damage, misuse, cabinet parts, knobs or consumable items.
- The product must be correctly installed and operated in accordance with the instructions contained in this manual.
- It must be used solely for domestic purpose.
- The guarantee will rendered invalided if the products is re-sold or has been damaged by inexpert repair.
- Specifications are subject to change without notice.
- The manufacturer disclaims any liability for the incidental or consequential damages.
- The guarantee is in addition to, and does not diminish your statutory or legal right.
- In the event of problem with the product with in the guarantee period call
Customer Service: 0345 6001714 www.argos-support.co.uk/

Guarantor: Argos Ltd
489 – 499 Avebury Boulevard
Central Milton Keynes
MK9 2NW