

Capella - 3+2 Drawer Chest

Assembly Instructions - Please keep for future reference

357/7097

339/2344

330/7559

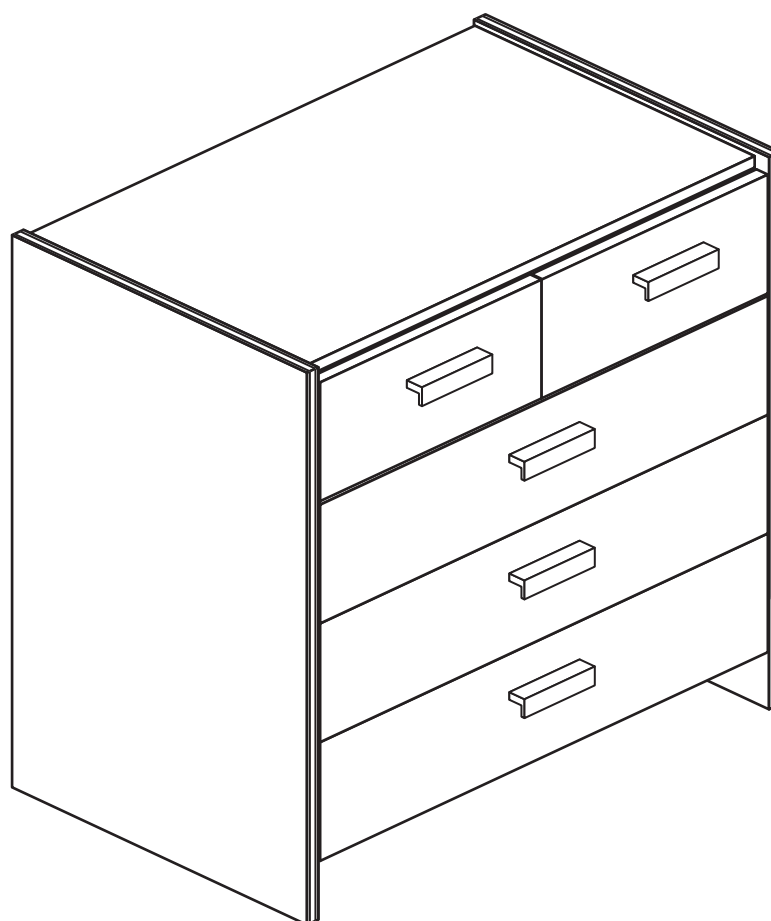

Dimensions

Width - 63cm

Depth - 39cm

Height - 75cm



**MADE IN
BRITAIN**

Important - Please read these instructions fully before starting assembly

If you need help or have damaged or missing parts, call the **Customer Helpline: 08456 400800**



Safety and Care Advice

Important - Please read these instructions fully before starting assembly

- **Warning:** This unit weighs approximately 24kgs. Please lift with care.

- Check you have all the components and tools listed on pages 2 and 3.

- Remove all fittings from the plastic bags and separate them into their groups.

- Keep children and animals away from the work area, small parts could choke if swallowed.

- Parts of the assembly will be easier with 2 people.

- Make sure you have enough space to layout the parts before starting.

- Do not stand or put weight on the product, this could cause damage.

- Assemble the item as close to its final position (in the same room) as possible.

- Assemble on a soft level surface to avoid damaging the unit or your floor (use opened out unit carton).



- We do not recommend the use of power drill/drivers **for inserting screws**, as this could damage the unit. Only use hand screwdrivers.

- **Safety note:** If there is any chance of this unit being pulled over by children etc. it is recommended that the unit is secured to a wall using suitable fixings (not supplied).

- Dispose of all packaging carefully and responsibly.

Care and maintenance

- Only clean using a damp cloth and mild detergent, do not use bleach or abrasive cleaners.

- From time to time check that there are no loose screws on this unit.

- This product should not be discarded with household waste. Take to your local authority waste disposal centre.

Note: If required the next page can be cut out and used as reference throughout the assembly. Keep this page with these instructions for future reference.

Components - Panels

If you have damaged or missing components, call the **Customer Helpline: 08456 400800** quoting the reference numbers below

Please check you have all the panels listed below

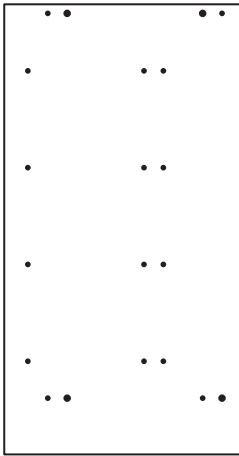

1 Left Side (D1039A)
(744 x 390mm)

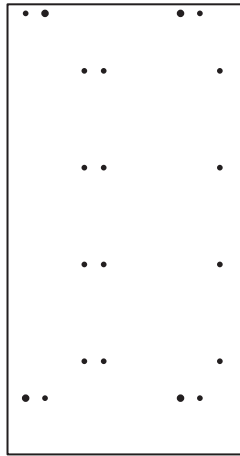

2 Right Side (D1040A)
(744 x 390mm)

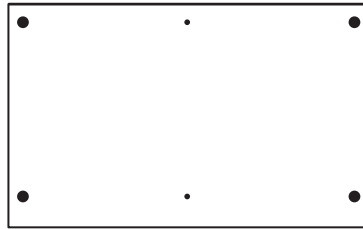

3 Top (DF1848A)
(596 x 369mm)



4 Rail (D1009A)
(596 x 103mm) x 2



5 Large Drawer Front (D1010A)
(592 x 157mm) x 3

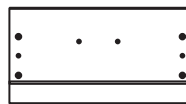

6 Small Left Drawer Front (DF1852A) (294 x 157mm)

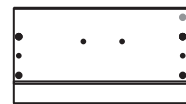

7 Small Right Drawer Front (DF1853A) (294 x 157mm)

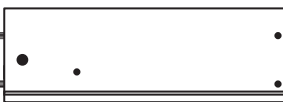

8 Left Drawer Side (W370-124LH)
(370 x 124mm) x 5

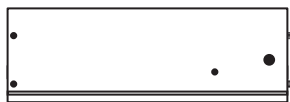

9 Right Drawer Side (W370-124RH)
(370 x 124mm) x 5

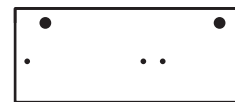

10 Divider (DF1851A)
(368 x 155mm)

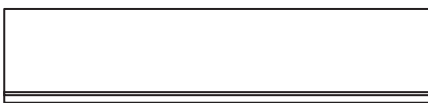

11 Large Drawer Back (W564-124)
(564 x 124mm) x 3

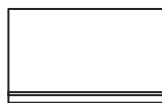

12 Small Drawer Back (W259-124)
(259 x 124mm) x 2



13 Large Drawer Base (T575-367)
(575 x 367mm) x 3

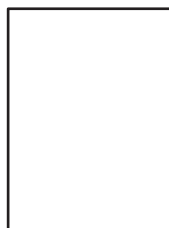

14 Small Drawer Base (T270-367)
(270 x 367mm) x 2

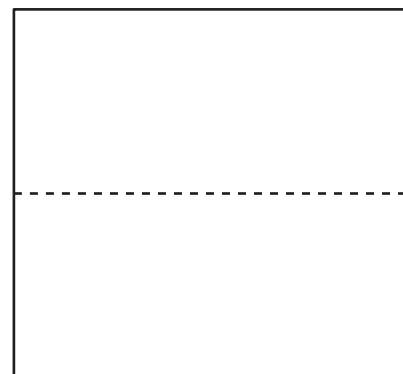

15 Back (X647-622A)
(647 x 622mm)











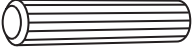
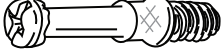
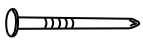



Components - Fittings

If you have damaged or missing components, call the **Customer Helpline: 08456 400800** quoting the reference numbers below

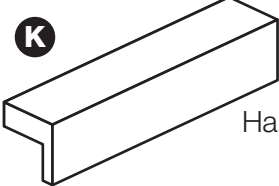
Please check you have all the fittings listed below

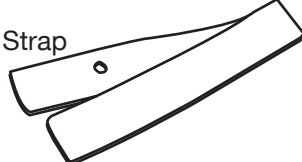
Note: The quantities below are the correct amount to complete the assembly. In some cases more fittings may be supplied than are required.

<p>A </p> <p>Wooden dowel (F22) x 8</p>	<p>B </p> <p>Metal dowel (F901) x 20</p>	<p>C </p> <p>Nail (F51) x 16</p>
<p>D </p> <p>Large locking nut (F900) x 10</p>	<p>E </p> <p>Small locking nut (F3) x 10</p>	<p>F </p> <p>Plastic Nail (F91) x 4</p>
<p>G </p> <p>25mm Screw (F50) x 10</p>	<p>H </p> <p>9mm Screw (F74) x 10</p>	<p>I </p> <p>9mm Screw (F73) x 20</p>
<p>J </p> <p>Drawer runner (F1004) x 10</p>		<p>K </p> <p>Handle (F930) x 5</p>
<p>L </p> <p>Knock-in Peg (F171GY) x 20</p>	<p>M </p> <p>Wedgex (F639) x 16</p>	<p>N </p> <p>Strap</p> <p> Screw  Washer x 2</p> <p>Overbalance protector kit (F269) x 1</p>

Tools required

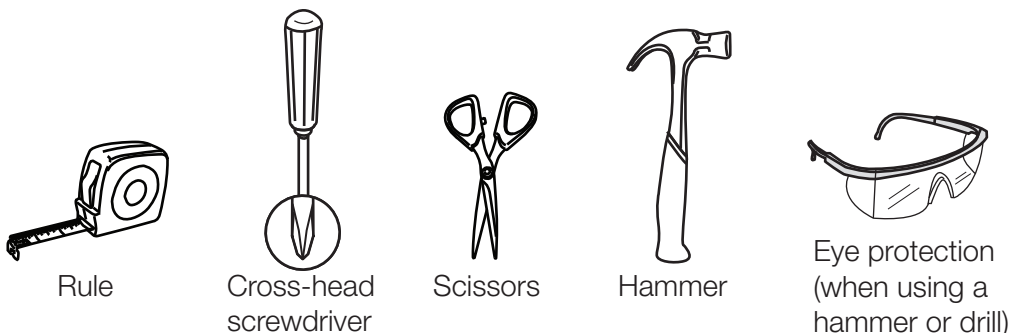

Ruler - Use this ruler to help correctly identify the screws

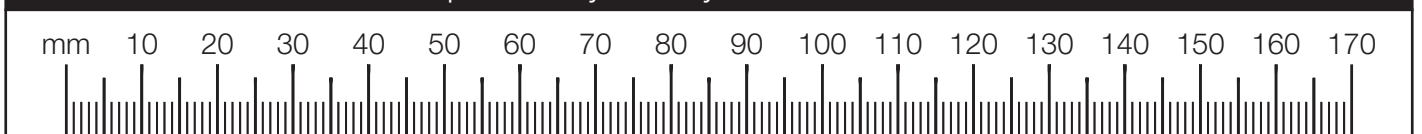

Assembly Instructions

If you have damaged or missing components, call the
Customer Helpline: 08456 400800 quoting the reference
numbers below

Step 1

Prepare the drawer fronts

Screw 2 metal dowels **B** into the holes shown on the back of each large drawer front **5**.

Note: Tighten the metal dowels up fully against the panels.

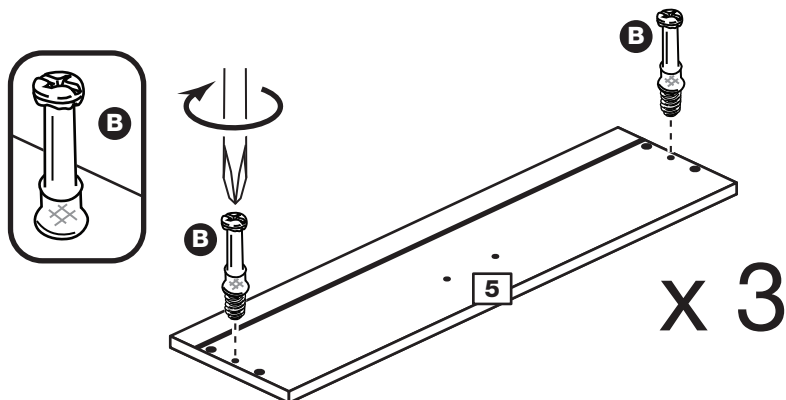

Step 2

Prepare the drawer sides

Insert a small locking nut **E** into the hole shown on the left drawer side **8** and right drawer side **9**.

Note: The arrow on the locking nut **must** point towards the hole in the edge of the panel.

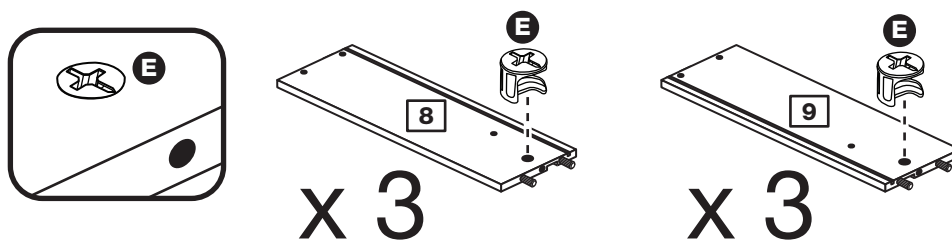

Step 3

Attach the drawer sides to the drawer fronts

Push the left drawer sides **8** and right drawer sides **9** onto the back of the large drawer fronts **5**.

Turn the small locking nuts **E** on the left drawer side **8** and right drawer side **9**.

Note: Turn the locking nuts **E** clockwise to secure panels - more than 1/2 a turn.

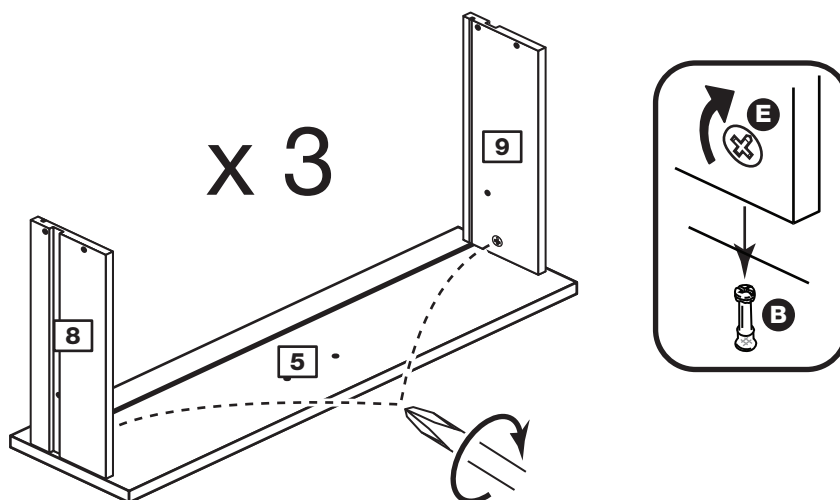

Assembly Instructions

Step 4

Fit the large drawer base

Slide the large drawer base **13** down the grooves in the drawer sides **8** and **9** and down into the groove in the large drawer front **5**.

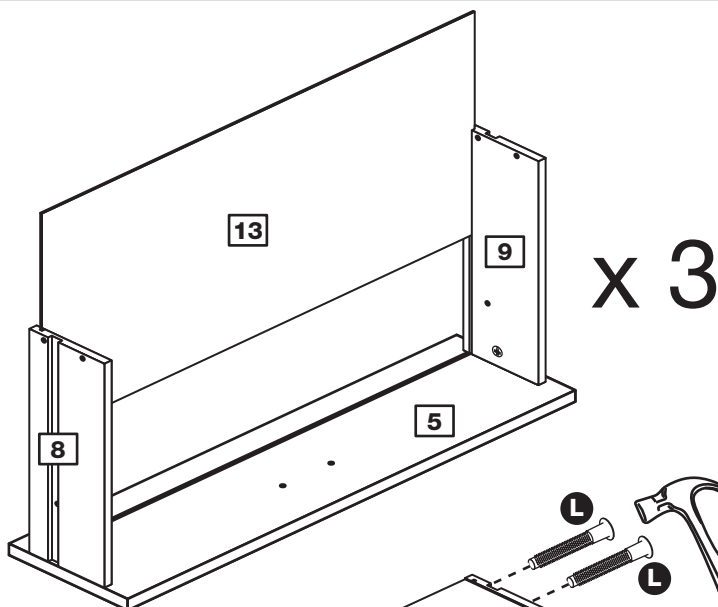

Step 5

Fit the large drawer back

Fit the large drawer back **11** between the drawer sides **8** and **9**.

Make sure that the drawer base **13** fits into the groove in the drawer back **11**.

Hold the drawer back **11** in position and tap the knock-in pegs **L** through the holes in the drawer sides **8** and **9**.

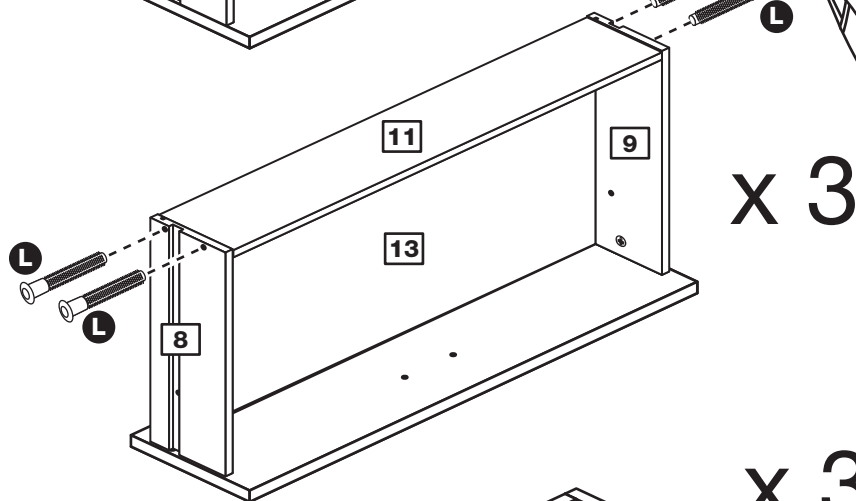

Step 6

Attach the handle

Attach a handle **K** to each large drawer front **5** using 2 screws **G**.

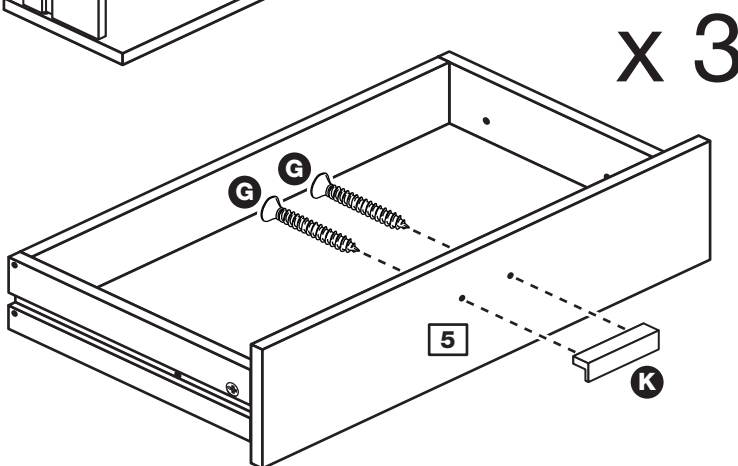

Step 7

Fit the wedgexes

Turn the large drawer assemblies over and slide 4 wedgexes **M** into the front and back grooves, as shown, and tighten up the screws.

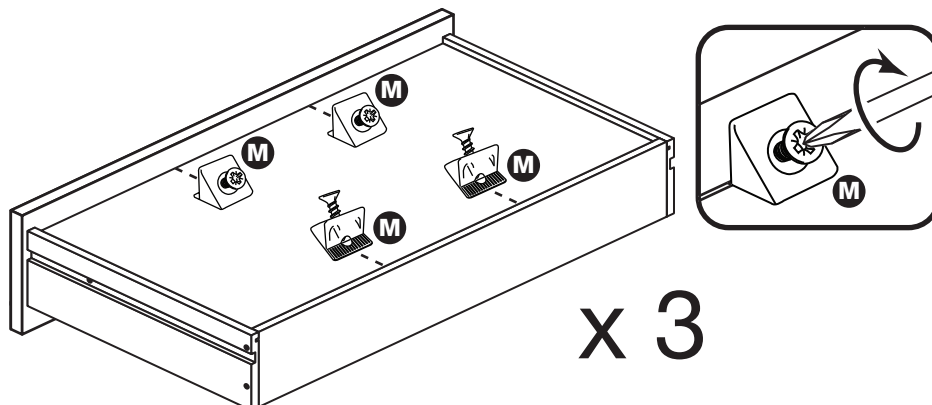

Assembly Instructions

If you have damaged or missing components, call the **Customer Helpline: 08456 400800** quoting the reference numbers below

Step 8

Prepare the 2 small drawer fronts

Screw 2 metal dowels **B** into the small left drawer front **6** and the small right drawer front **7**.

Note: Tighten the metal dowels up fully against the panels.

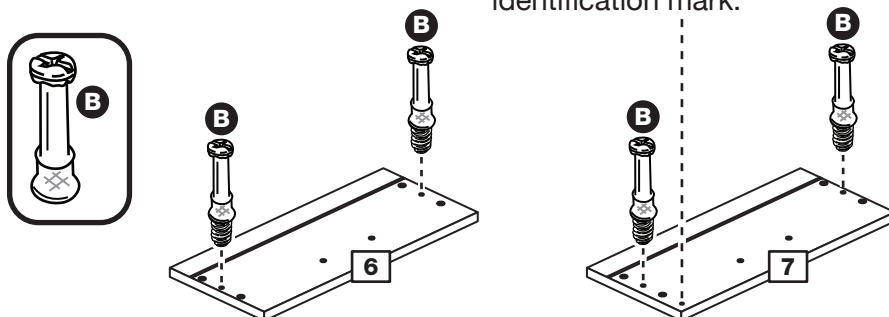

Note: The small right drawer front has a shallow identification mark.

Step 9

Prepare the drawer sides

Insert a small locking nut **E** into the hole shown on the left drawer side **8** and right drawer side **9**.

Note: The arrow on the locking nut **must** point towards the hole in the edge of the panel.

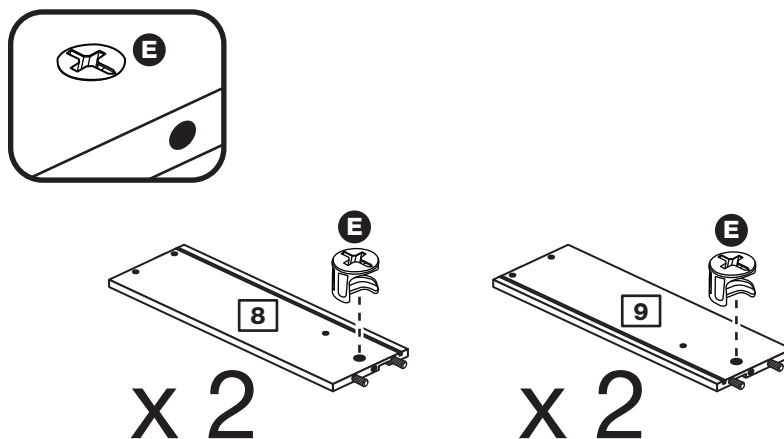

Step 10

Attach the drawer sides to the small drawer fronts

Push the left drawer sides **8** and right drawer sides **9** onto the back of the 2 small drawer fronts **6** and **7**.

Turn the small locking nuts **E** on the left drawer side **8** and right drawer side **9**.

Note: Turn the locking nuts **E** clockwise to secure panels - more than 1/2 a turn.

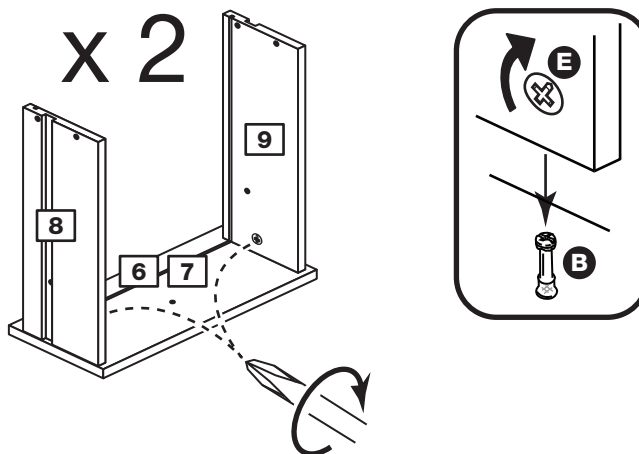

Assembly Instructions

Step 11

Fit the small drawer base

Slide the small drawer base **14** down the grooves in the drawer sides **8** and **9** and down into the groove in the small drawer fronts **6** and **7**.

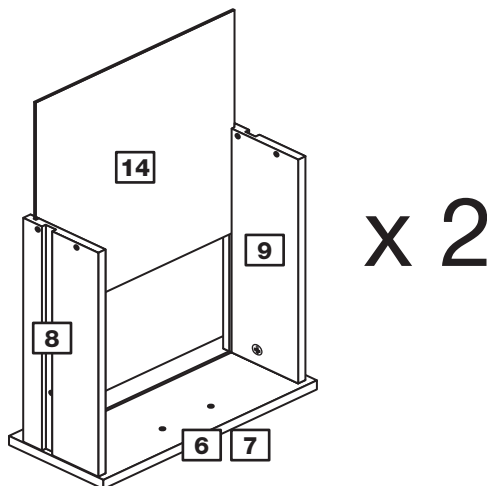

Step 12

Fit the small drawer back

Fit the small drawer back **12** between the drawer sides **8** and **9**. Make sure that the small drawer base **14** fits into the groove in the small drawer back **12**.

Hold the small drawer back **12** in position and tap the knock-in pegs **L** through the holes in the drawer sides **8** and **9**.

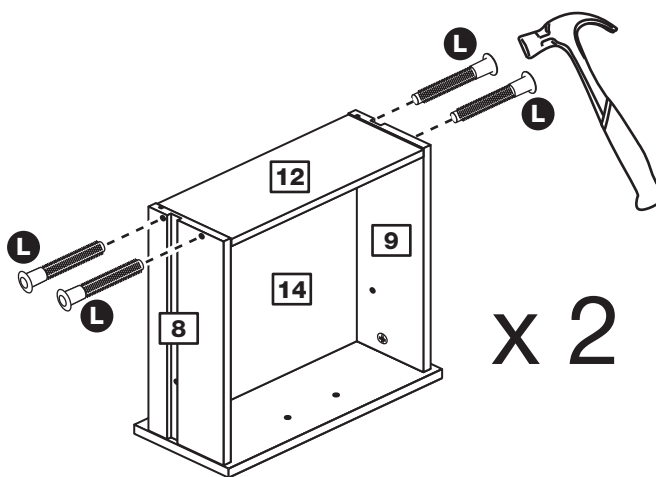

Step 13

Attach the handles

Attach a handle **K** to each small drawer front **6** and **7** using 2 screws **G**.

Note: Do not overtighten the screw.

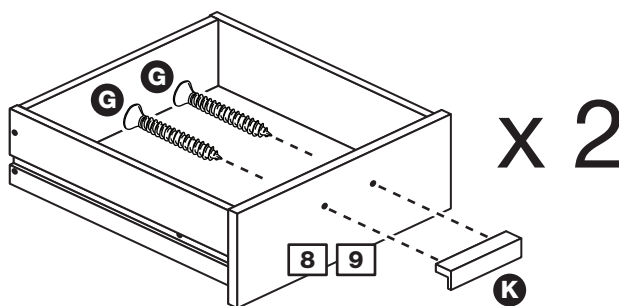

Step 14

Fit the wedgexes

Turn the drawer assemblies over and slide 2 wedgexes **M** into the front and back grooves, as shown, and tighten up the screws.

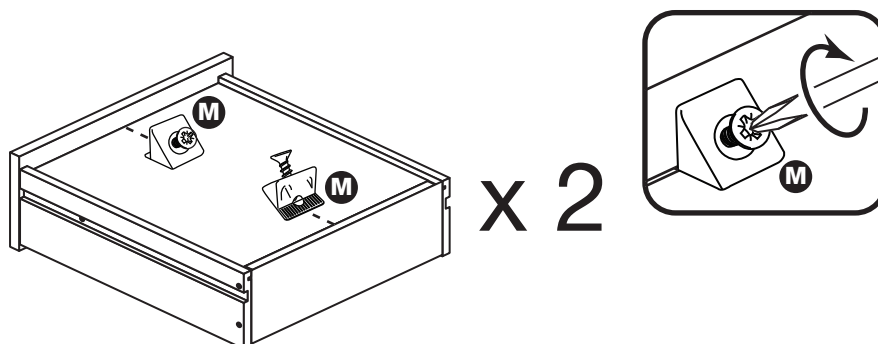

Assembly Instructions

Step 15

Prepare the left side

a: Place 4 runners **J** on the left side **1**. Slide back the top of the runner and use the 1st hole from the front to fit the 1st screw **I**.

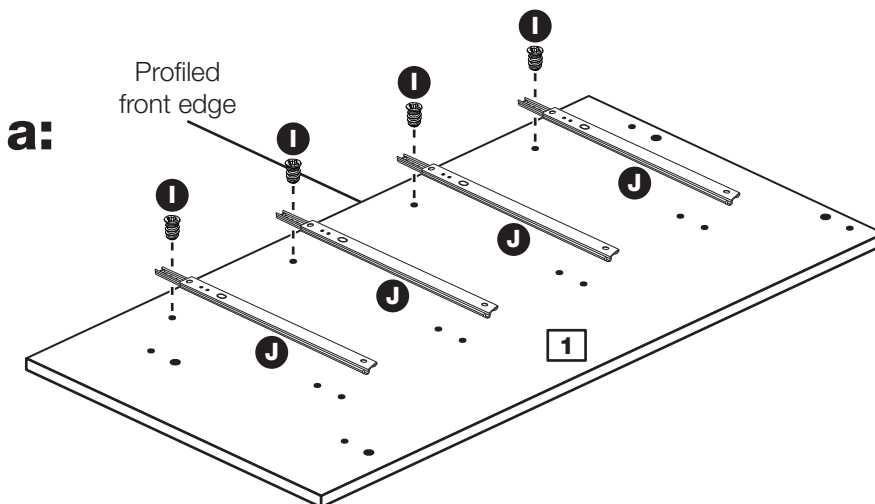
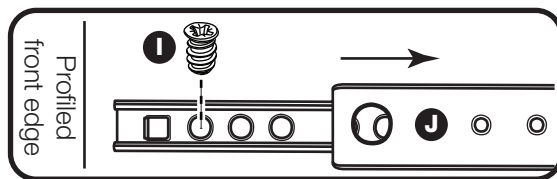

b: Slide the runner back the other way and use the 3rd hole from the back to fit the 2nd screw **I**.

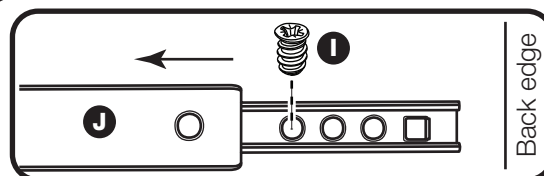
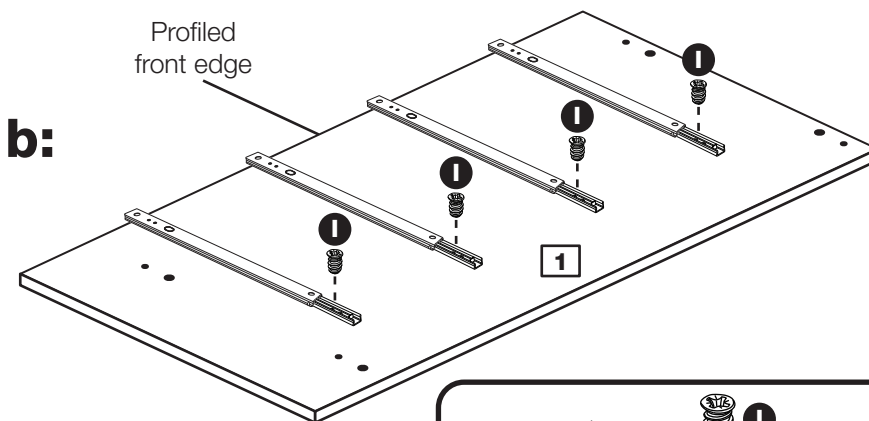

c: Screw 4 metal dowels **B** into the left side **1**.

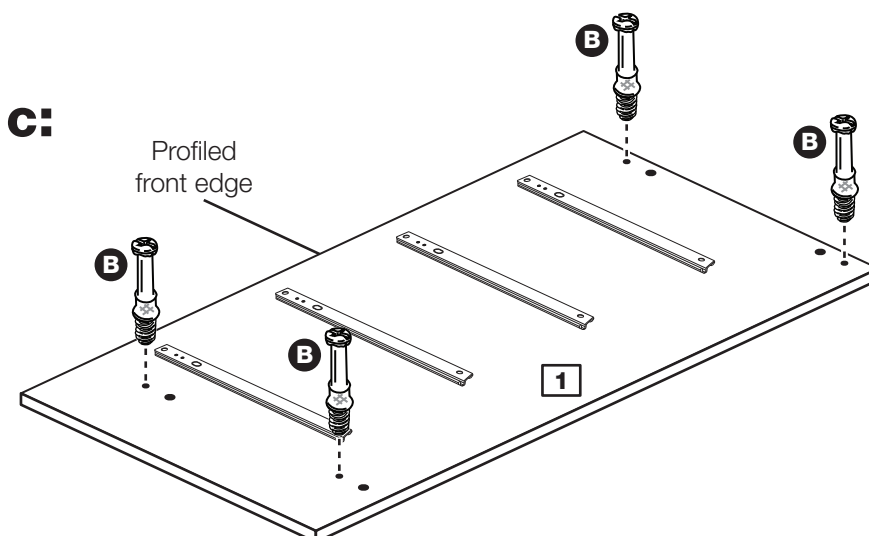

Assembly Instructions

Step 16

Prepare the right side

a: Place 4 runners **J** on the right side **2**. Slide back the top of the runner and use the 1st hole from the front to fit the 1st screw **I**.

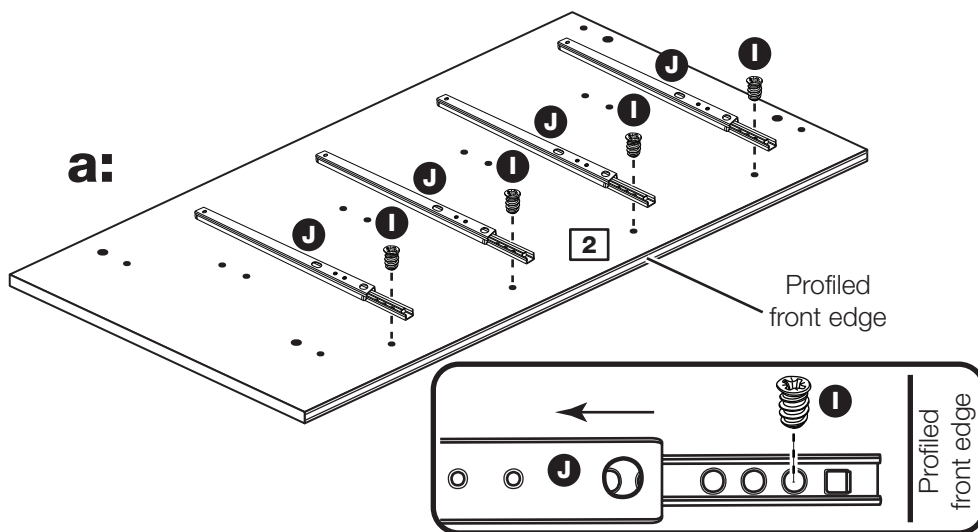

b: Slide the runner back the other way and use the 3rd hole from the back to fit the 2nd screw **I**.

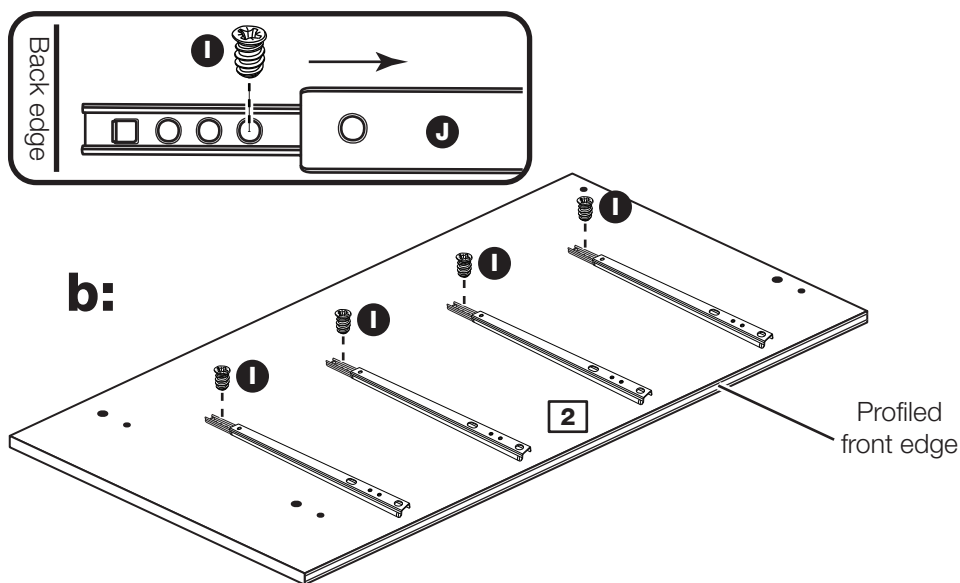

c: Screw 4 metal dowels **B** into the right side **2**.

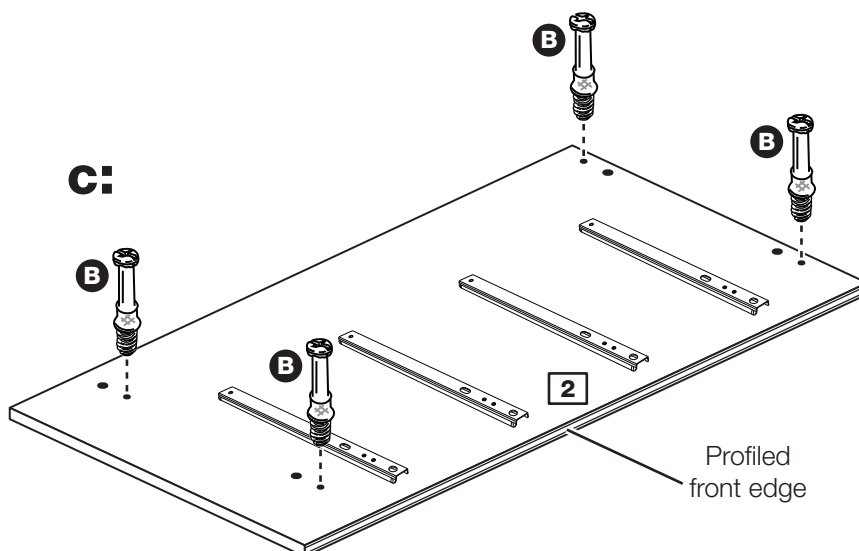

Assembly Instructions

Step 17

Prepare the top

Tap 4 wooden dowels **A** into the top **3** as shown.

Note: Wooden dowels **must not** stick out from the edge by more than 10mm or they may damage other panels.

Insert 4 large locking nuts **D** into the top **3**.

Note: The arrow on the locking nut **must** point towards the hole in the edge of the panel.

Screw 2 metal dowels **B** into the top **3**.

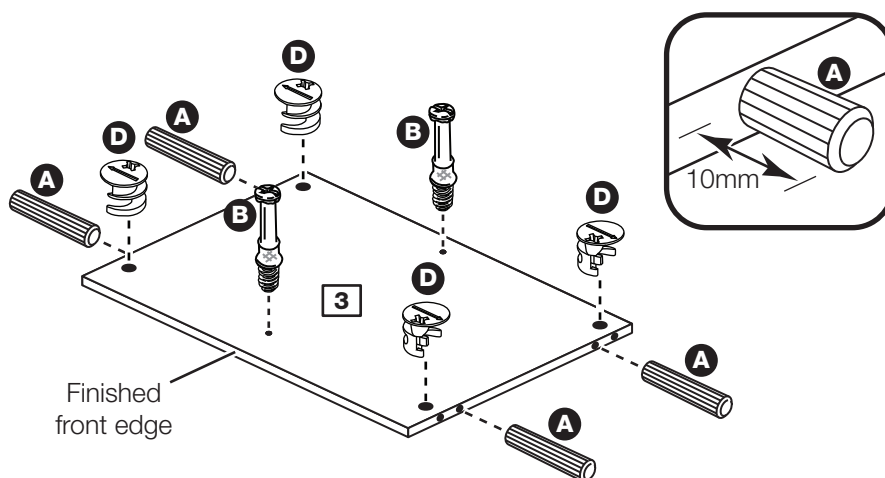

Step 18

Prepare the rails

Tap 2 wooden dowels **A** into each of the rails **4**.

Insert 2 large locking nuts **D** into each of the rails **4**.

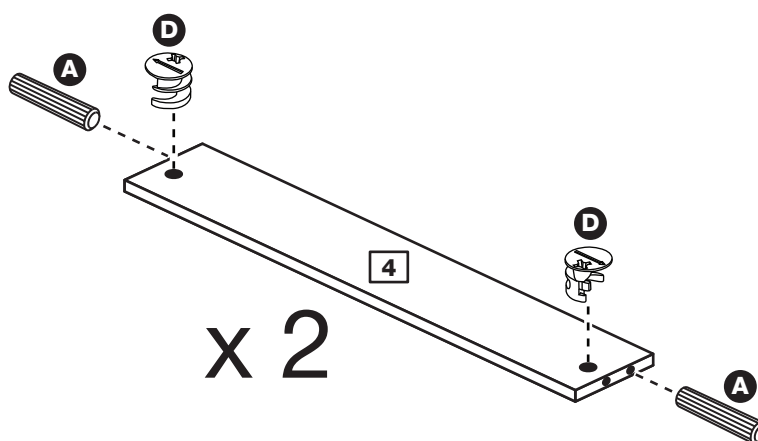

Assembly Instructions

Step 19

Prepare the divider

a: Place a runner **J** on the divider **10** as shown. Slide back the top of runner and use the 1st hole from the front to fit the 1st screw **I**.

b: Slide the runner **J** back the other way and fit the 2nd screw **I** into the corresponding hole in the divider **10**.

Insert 2 large locking nuts **E** into the divider **10**.

Turn the divider over

c: Place a runner **J** on the divider **10** as shown. Slide back the top of runner and use the 1st hole from the front to fit the 1st screw **I**.

d: Slide the runner **J** back the other way and fit the 2nd screw **I** into the corresponding hole in the divider **10**.

Note: Due to the manufacturing process, the 2 holes for the large locking nut can be on either surface of the divider.

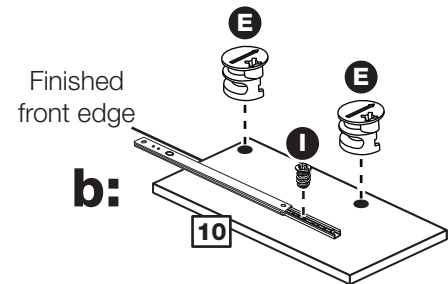
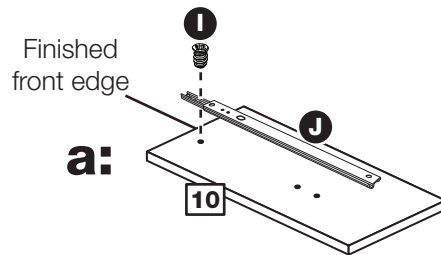
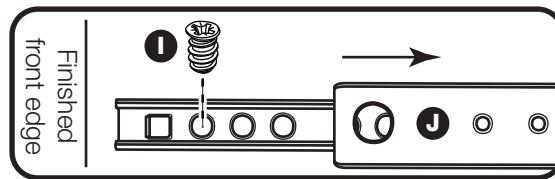

Turn the divider over

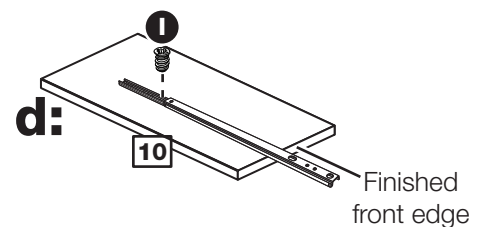
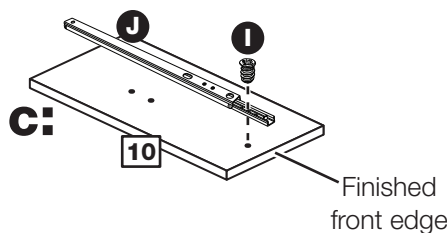
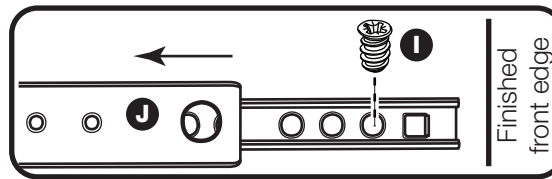

Step 20

Join the divider and top

Push the top **3** onto the divider **10** as shown.

Use a screwdriver to tighten the 2 large locking nuts **D** fitted to the divider **10**.

Note: Turn the large locking nuts **D** as far as they will go - more than 1/2 a turn.

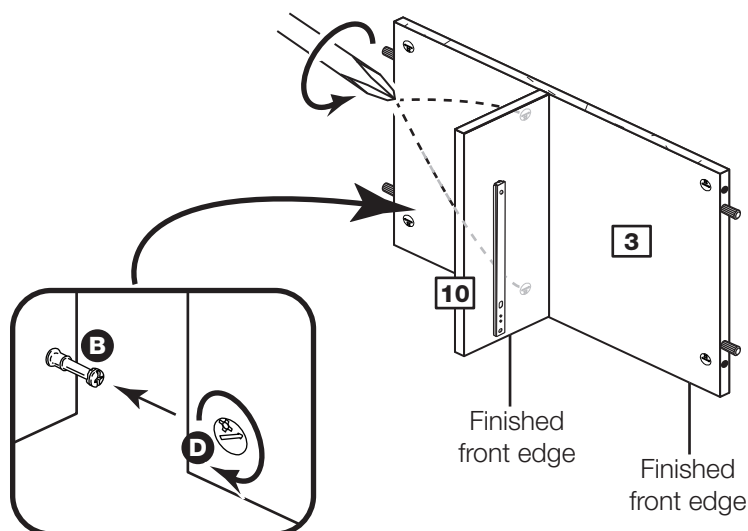

Assembly Instructions

Step 21

Join the right side and top

Push the top **3** onto the right side **2** as shown.

Use a screwdriver to tighten the 2 large locking nuts **D** fitted to the top **3**.

Note: Turn the large locking nuts **D** as far as they will go - more than 1/2 a turn.

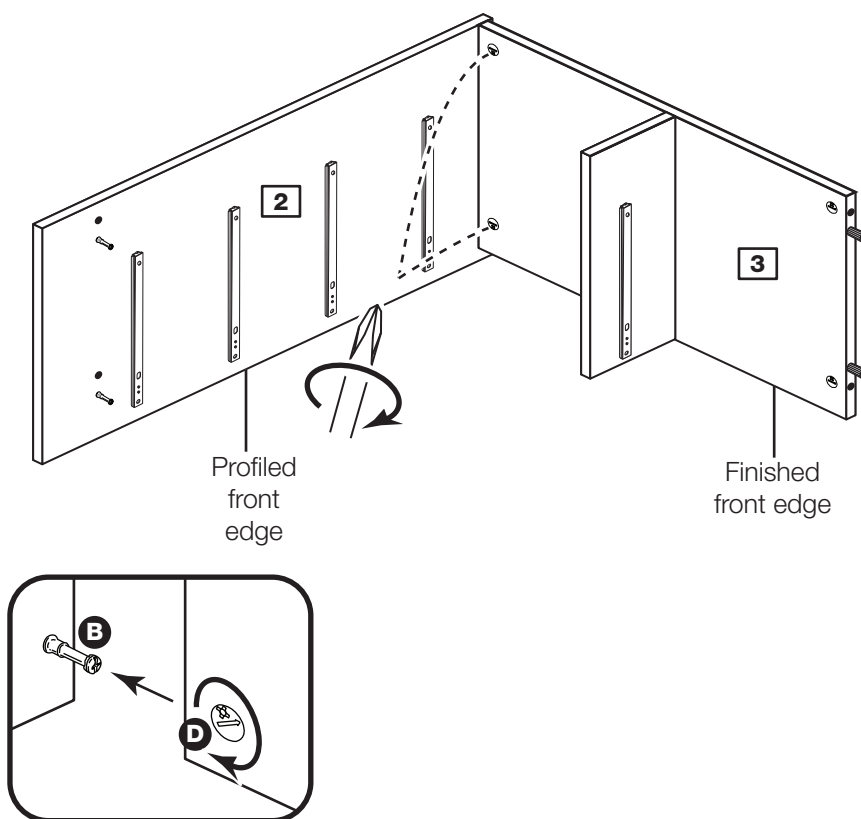

Step 22

Fit the rails

Push the rails **4** onto the right side **2** as shown.

Use a screwdriver to tighten the 2 large locking nuts **D** fitted to the rails **4**.

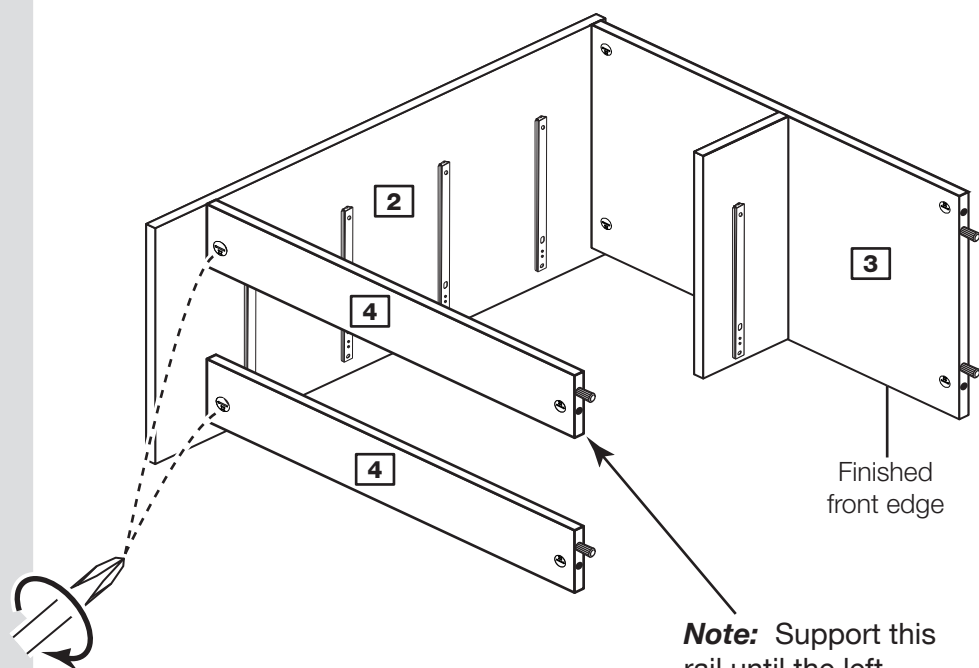

Note: Support this rail until the left side has been fitted in the next step.

Assembly Instructions

Step 23

Fit the left side

Push the left side **1** onto the assembly.

Use a screwdriver to tighten the 4 large locking nuts **D** fitted to the top **3** and the rails **4**.

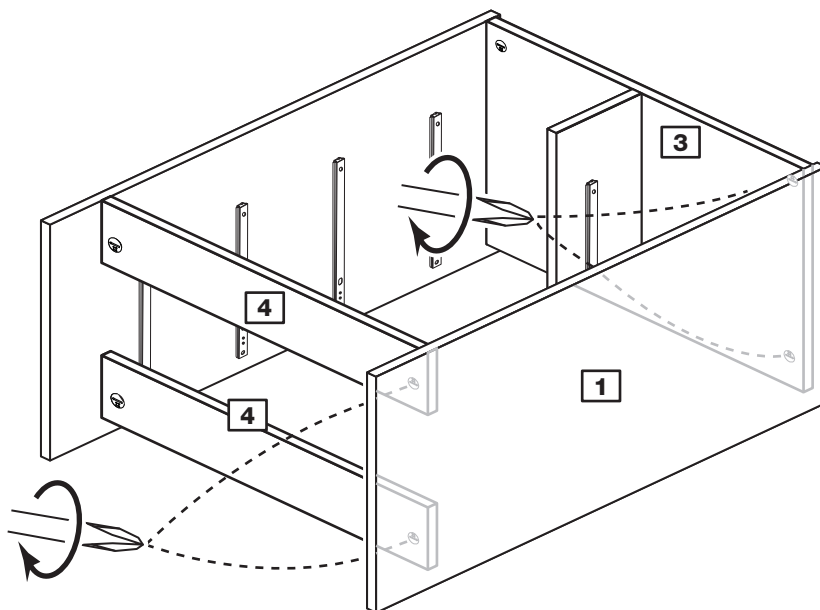

Step 24

Fit the back

a: Square up the unit by making sure that measurement **x** to **x** equals **y** to **y**.

b: Place the back **15** onto the unit.

Nail **C** around the outside edges of the back **15**.

Note: Nails should be spaced about 150mm apart.

Fit the 4 plastic nails

Tap 2 plastic nails **F** into the bottom edge of each of the sides **1** and **2**.

Stand the unit up for the next step.



Warning: The unit is heavy. Lift with care.

a: The measurement from top corner X to bottom corner X must be equal to the measurement from top corner Y to bottom corner Y

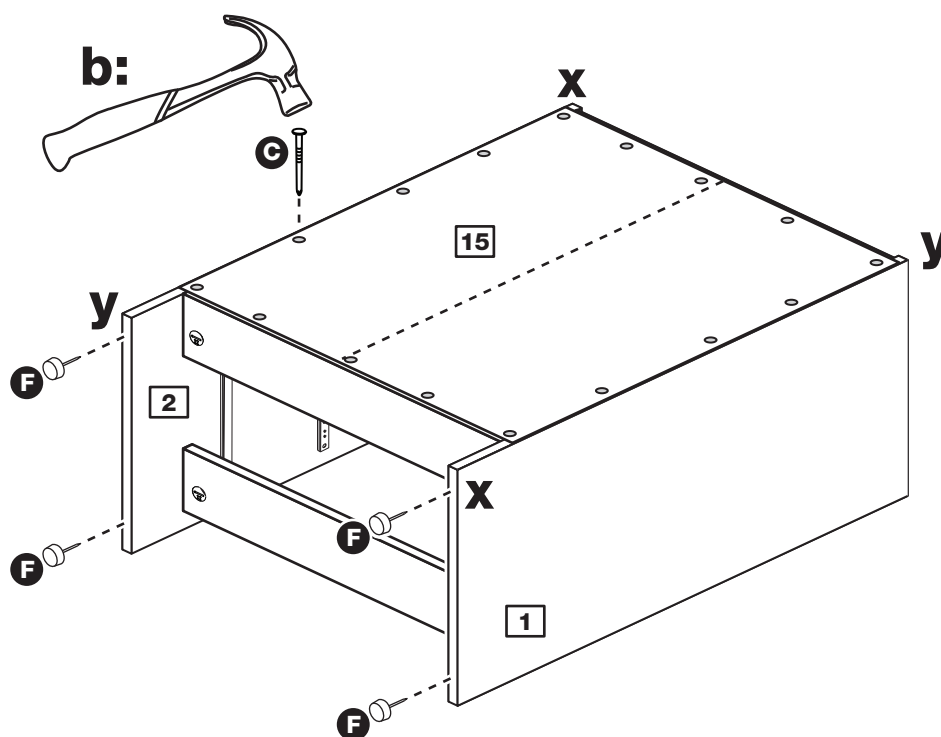

Assembly Instructions

Step 25

Fit the drawers

Starting with the bottom drawer, slide both the runners **J** forward and locate the drawer sides **8** and **9** between them, lining up the holes in the drawer wrap with the 2nd 'threaded' holes in the runners **J**.

Working from the inside of the drawer, insert 2 screws **H** through the drawer sides and out into the 2nd threaded hole in the runner.

Note: Do not overtighten the screws **H**. If they catch on the runner you may need to loosen them slightly.

Assembly is complete



Warning: The unit is heavy. Lift with care.

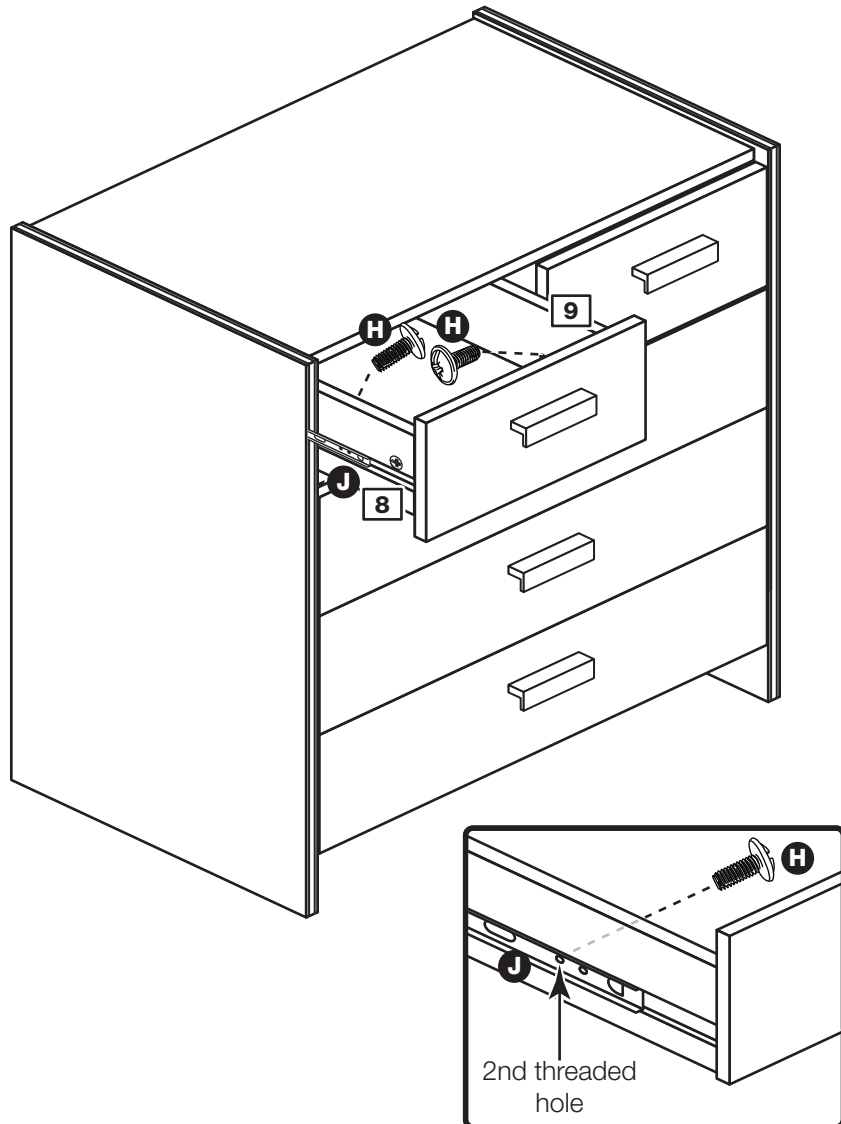

Assembly Instructions

Step 25

Fit the overbalance protector

To prevent possible overbalancing we recommend that this unit is secured to a suitable wall by fitting of the overbalance protector kit **N** to the unit or an alternative fixing method of your choice.

Wall fixings are not supplied as they will need to suit the wall type.

Fit one end of the strap to the wall

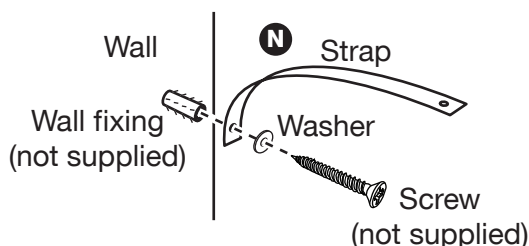

Fit the other end of the strap to a suitable position on the unit

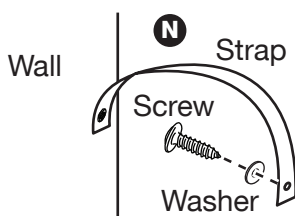

Warning: Take care when drilling the wall that you do not drill into any pipes, wires etc. If in doubt, consult an expert

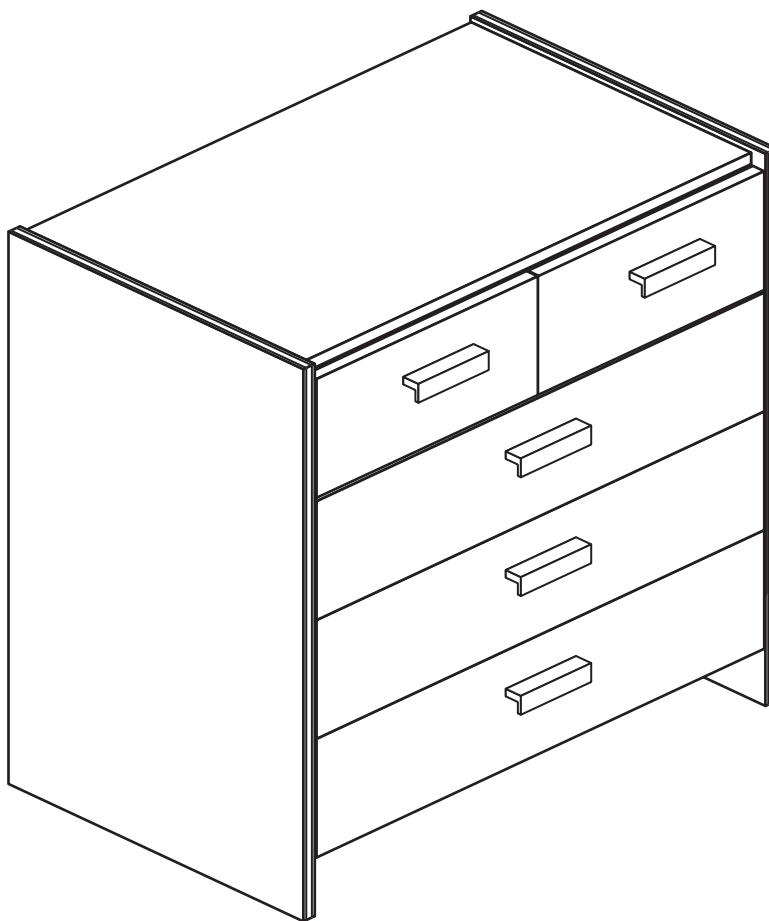

If you need help or have damaged or missing parts, call the Customer Helpline: 08456 400800 and quote the reference numbers on the component pages.

Argos Ltd, 489-499 Avebury Boulevard, Central Milton Keynes, MK9 2NW