

# Sovereign Electric Chainsaw

Assembly Manual

SCS718A

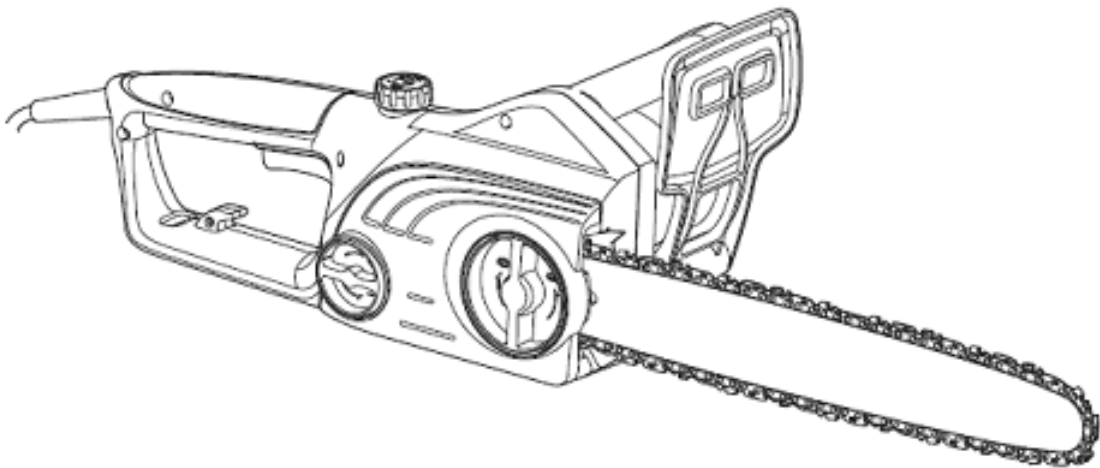

**Important** - Please read these instructions fully before starting assembly

These instructions contain important information that will help you get the best from your chainsaw, ensuring it is assembled correctly and safely.

If you need help or have damaged or missing parts, call the Customer Helpline on **01904 727503** prior to returning product to store.

# Contents

Safety Information .....	3
Warning Symbols.....	3
General Safety.....	3
Personal Safety .....	3
Intended Use .....	4
In the Box .....	5
Parts.....	5
Assembly.....	6
Preparing to Assemble the Electric Chainsaw .....	6
Step 1 - Tensioning the saw chain.....	6
Step 2 - Chain lubrication .....	7
Step 3 - Connection to the power supply .....	7



# Safety Information

**Important - Please read these instructions fully before starting assembly**

## Warning Symbols

The following warning symbols appear throughout this assembly manual and indicate the appropriate safety measures you should take when assembling and operating the electric chainsaw.



This symbol indicates there is a danger of serious personal injury or death if you do not observe the warning.



This symbol indicates that there is a danger of damaging your hands if you do not wear thick, protective gloves.

## General Safety



**WARNING!** Keep this assembly manual in a safe place for future reference.



**WARNING!** Always ensure anyone intending to operate this electric chainsaw is fully conversant with the content of this assembly manual prior to assembling, maintaining or operating the chainsaw.



**WARNING!** Perform assembly operations described in this manual. Failure to observe this warning may lead to serious injury, death, or damage to the electric chainsaw.



**WARNING!** Always take care when removing the packaging to prevent damage to you or to the electric chainsaw.



**IMPORTANT!** Before assembling the electric chain saw, check all the parts indicated in the manual are in the box. Inspect all the parts for signs of damage. Do not assemble the electric chainsaw if you observe any damaged components.

## Personal Safety



**WARNING!** Only operate the electric chainsaw if you are wearing the correct Personal Protective Equipment(PPE)as described in the following warnings.



**WARNING!** Always wear suitable gloves when operating electric chainsaw to protect your hands from flying debris and/or sharp objects.



# Safety Information

**Important - Please read these instructions fully before starting assembly**

## **Intend Use**

1. The product is designed to sawing wood only. The saw is not designed for any other types of application (e.g. cutting of brickwork, plastic or food). Observe the technical data for the maximum cutting capacity. Do not work exceeding the stated maximum capacity.
2. This product is intended for private use only, not for any commercial applications. It may not be used for any purposes other than those described.
3. Attachments must be used according to the respective functions and in accordance with this instruction manual.
4. This product is not intended for use by persons (including children) with reduced physical, sensory or mental capabilities, or lack of experience and knowledge, unless they have been given supervision or instruction concerning use of the product by a person responsible for their safety.
5. Children should be supervised to ensure that they do not play with the product.

# In the Box

## Parts

- |                          |                       |   |
|--------------------------|-----------------------|---|
| 1. Rear handle           | 6.Chain               | 10.Hand guard with safety chain brake trigger |
| 2.Safety lock-off button | 7.Front handle        | 11.SDS tension knob                           |
| 3.Trigger                | 8.Motor and air slots | 12.Chain cover                                |
| 4.Oil Filler cap         | 9.Plug and cord       | 13.Clamp knob                                 |
| 5.Chain bar              |                       |   |

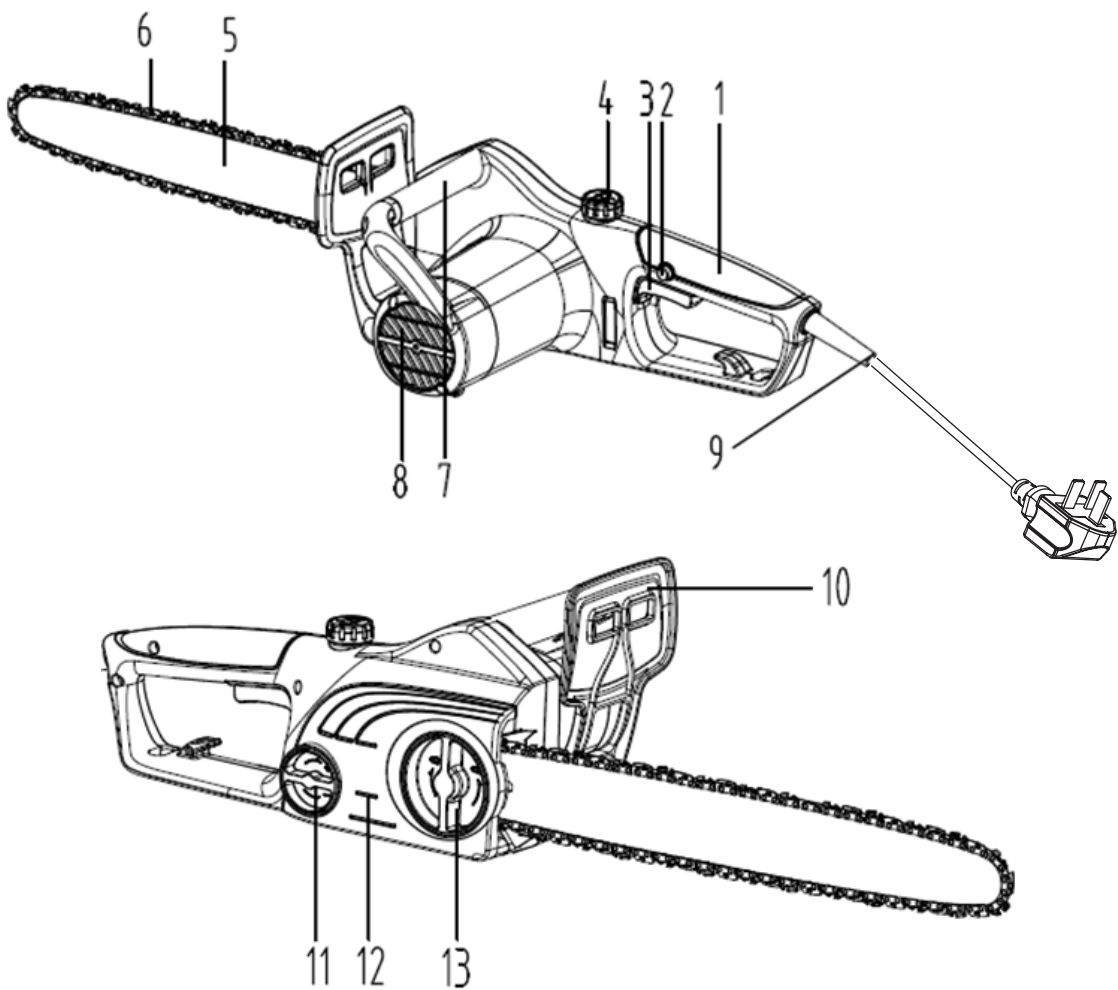

# Assembly

## Preparing to assemble the Electric Chainsaw



**WARNING!** Always wear protective gloves when working with the chainsaw and employ only original parts. Pull out the power plug before doing any work on the chainsaw itself-injury hazards!

1. Remove all parts of the electric chainsaw from the box and carefully remove all packaging. Take care not to lose any instructions which may be affixed to the parts. These provide important information which will be required while assembling the electric chainsaw.
2. The tool is completely assembled on delivery. Before you start up the electric chainsaw, adjust the chain, fill up with chain oil and check the automatic lubrication and chain brake function.



**NOTE!** Always recycle the packaging in accordance with local recycling schemes.

## Step 1 - Tensioning the saw chain



**WARNING!** An incorrectly tensioned chain may break or spring off, leading to danger or injury. Test the electric saw before every start and the chain tension after every hour of sawing.

1. Ensure that the chain brake has been released, that is, that the chain brake lever is pulled up against the front handle (7).
2. Loosen the clamp knob (13) so the chain bar move.
3. Adjust the SDS chain tension knob (11) in the “+” direction to increase tension or in the “-” direction to slacken the chain. Adjust the chain so an entire drive link is just visible.
4. Ensure the chain rotates smoothly on the bar, then fully tighten the SDS knob and lock in place with the clamp knob (13).
5. When the saw chain is tensioned with 9N (approx. 1kg), the gap between the saw chain and the guide rail may not be more than 2mm.



**NOTE!** Do not over tension the chain as this will reduce life of chain bar and motor.

**NOTE!** With a correctly tensioned chain you will get good cutting performance and a longer life.

**NOTE!** The chain is correctly tensioned if it does not sag at the rail underside and can be rotated completely around with the gloved hand.

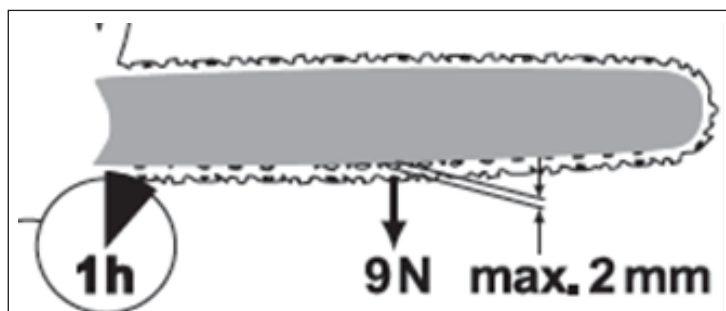

# Assembly

## Step 2 - Chain lubrication



**WARNING!** The rail and chain must never be without oil. If you operate the electric chainsaw with too little oil, the cutting performance and the lifetime of the saw chain is reduced, since the chain becomes blunt faster. You can identify a case of too little oil where smoke development or discoloration of the rail occurs.



**NOTE!** This chainsaw is equipped with an oil automatic system. As soon as the motor is speeded up, the oil also flows faster to the chain bar.

**NOTE!** Check the oil fill level and regularly top up with oil. The oil tank holds 100 ml oil.



**NOTE!** If you have no oil available, use chain lubrication oil with low adhesive additive content. The type of motor oil SAE#10W-30 is recommended.

1. Unscrew the oil fill cap (4) and fill up with chain oil.

2. Wipe off any spilled oil and close the cap again.

3. Switch on the chainsaw and hold it above a bright background. The saw must not touch the ground.

4. If an oil trace can be seen, the chainsaw is working trouble-free. Select the oil regulator to prevent oil droplets forming, but also to prevent the chain from ever running dry.



**NOTE!** When the chainsaw is put away in storage, set the oil regulator to zero.

### check the chain lubrication

--Never saw when a sufficient chain lubrication is not guaranteed. Otherwise the life of the sawing device will be reduced. Before starting work check the oil level in the tank and the oil feeding. Check the fed oil quantity by following the instructions below:

--Start the electric chainsaw

--Hold the running chain saw approx. 15cm above a trunk or the ground (use an appropriate surface)

If the lubrication is sufficient, you will see a light oil trace because oil will be centrifuged from the chain saw.

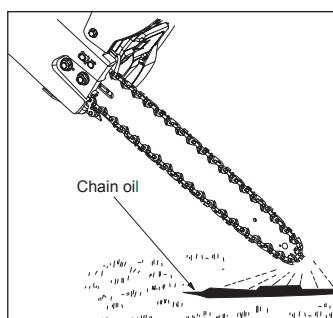

# Assembly

## Step 3 - Connection to the power supply



**WARNING!** Read all of the instructions of this manual before attempting to connection the power supply for your tool. Switch on the chainsaw only when chain bar, saw chain and sprocket chain wheel covering are correctly assembled.



**WARNING!** If the insulation on a power cable or extension lead is found to be cut or damaged, do not touch it! Disconnect the power supply immediately and have the damaged cable replaced by authorized service agent.



**WARNING!** If operating the appliance in a damp location is unavoidable, use a residual current device(RCD) protected supply. Use of an RCD reduces the risk of electric shock.



**WARNING!** Use only extension cords suitable for outdoor use, preferably with a high visibility cable colour. Always unwind all extension cables fully, coiled cables can overheat and reduce the efficiency of your product.



**NOTE!** For extension cables up to 15metres, use a wire cross section of 2.5 mm<sup>2</sup>.



**WARNING!** This product is designed to operate on 230-240 VAC 50Hz. The voltage and current must comply with the information on the ratings label!



**NOTE!** This electric chainsaw is fitted with a non-rewireable plug. If it is necessary to change the fuse in the plug, the fuse cover becomes lost or damaged; the plug must not be used until a suitable replacement is obtained.



**WARNING! A 13amp fuse must be fitted.**

- 1). Make sure the on/off switch (3) and safety chain brake trigger (10) is in its off position.
- 2). Double the extension cord about a foot from the end. Lead the loop through the hole on the rear handle and hook the loop over the cord restrainer. Gently pull on the cord to ensure that it is firmly attached at the handle.
- 3). Connect the cord to a suitable socket.



# Sovereign Electric Chainsaw

Operation and Maintenance Manual

SCS718A

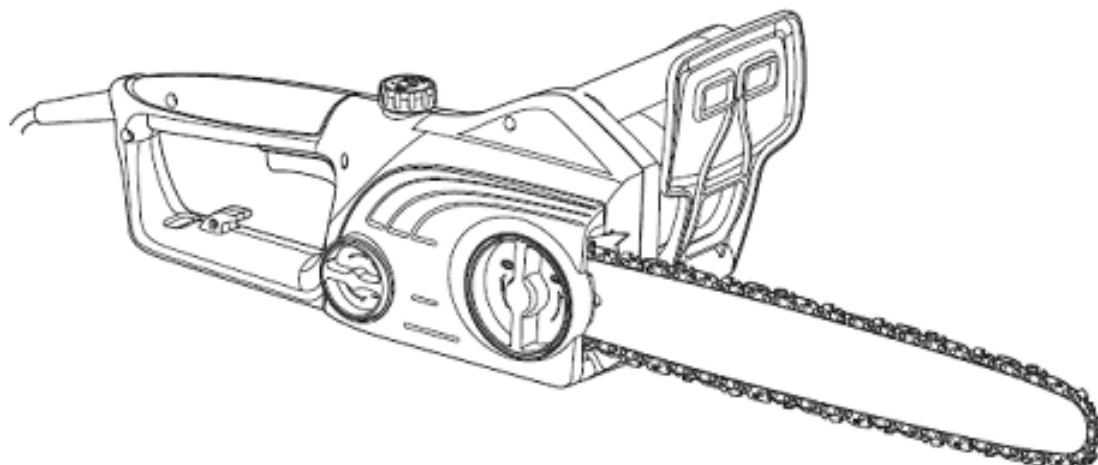

# SOVEREIGN

**Important** - Please read these instructions fully before operating or maintaining your chainsaw

These instructions contain important information that will help you get the best from your chainsaw, ensuring it is assembled correctly and safely.

If you need help or have damaged or missing parts, call the Customer Helpline on **01904 727503** prior to returning product to store.

# Contents

Safety Information .....	3
Preparing to Operate the Electric Chainsaw .....	9
Operating the Electric Chainsaw .....	10
Maintenance and Repair .....	17
Storage and Transportation .....	18
Troubleshooting .....	19
Technical Data.....	20
Recycling and Disposal.....	20
Plug Replacement.....	21
Guarantee .....	22
Declaration of Conformity .....	23

# Safety Information

Important - Please read these instructions fully before operating or maintaining

## Warning Symbols

The following warning symbols appear through this manual and indicate the appropriate safety measures you should take when operating and maintaining the chainsaw.



**Warning!**



**Read the instruction manual**



**Conforms to all relevant safety standards.**



**Wear personal protective equipment. Basically, wear protective goggles or, even better, face protection, ear protection, safety helmet, cut-protection working clothes.**



**Wear protective gloves.**



**Wear cut-protection safety boots with anti-slip soles.**



**Do not expose to rain.**



**WARNING! Remove plug from the mains immediately if the cable is damaged or cut.**

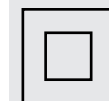

**Double insulation.**



**SWITCH OFF! Remove plug from mains before cleaning or maintenance.**



**Caution! Spring-back! Be careful of spring-back of the machine during work.**

# Safety Information

Important - Please read these instructions fully before operating or maintaining

## Warning Symbols



Hold the chainsaw with both hands while operating.



Brake is engaged and product can not be started or run.



Brake is disengaged and product can be operated.



Take a power tool in the domestic waste! In accordance with European Directive 2011/65/EC on waste electrical and electronic equipment and its implementation in national law, Electric tools collected separately and environmentally friendly recycling are fed. Take advantage of the collection facilities. Ask your local government for the collection systems. If electrical appliances are disposed of, can be poisoned for years while the cause hazardous substances into the groundwater and entering the food chain, or flora and fauna.



Guaranteed sound power level



Max cutting length 345mm

# Safety Information

Important - Please read these instructions fully before operating or maintaining

## General Safety



**WARNING!** Keep this operating and maintenance manual in a safe place for future reference.



**WARNING!** Read the instructions carefully. Be familiar with the controls and the proper use of the equipment.



**WARNING!** Never allow children or people unfamiliar with these instructions to use the electric chainsaw. Local regulations can restrict the age of the operator.



**WARNING!** This appliance is not intended for use by persons (including children) with reduced physical, sensory or mental capabilities, or lack of experience and knowledge, unless they have been given supervision or instruction concerning use of the appliance by a person responsible for their safety.



**WARNING!** Do not touch the rotating saw chain until they are stopped.

## Preparation

a) **This machine can cause serious injuries.** Read the instruction carefully for the correct handling, preparation, maintenance, starting and stopping of the appliance. Be familiar with the controls and the proper use of the appliance. Read and understand the operator's manual and observe the warnings and instruction labels affixed to the appliance.

b) **Users.** Never allow children or people unfamiliar with these instructions to use the appliance. Local regulations may restrict the age of operator. Never operate the tool under the influence of alcohol, medication or drugs.

c) **Use appropriate tool.** This device is only intended for sawing wood in private house and hobby gardens only. Do not force small tools or attachments to do the job of a heavy duty tool.

## Work Area Safety

d) **Keep work areas clean.** Cluttered or dark areas invite accidents.

e) **Consider work area environment.** Do not expose your tool to high humidity or rain. Do not use your tool in damp and wet conditions. Keep the work area well lit.

f) **Keep all bystanders, children, and pets at least 50 feet away.** The operator or user is responsible for accidents or hazards occurring to other people or the property.

g) **Do not operate power tools in explosive atmospheres, such as in the presence of flammable liquids, gases or dust.** Power tools create sparks which may ignite the dust or fumes.

## Safety Information

Important - Please read these instructions fully before operating or maintaining

### Personal Safety

- h) **Use personal protective equipment (PPE).** Always wear eye protection and ear protection. Protective equipment such as dust mask, non-skid safety shoes, hard hat, or hearing protection used for appropriate conditions will reduce personal injuries.
- i) **Dress appropriately. Do not wear loose clothing or jewelry, as these can be caught in moving parts.** Preferably wear non-slip footwear when working outdoors. Wear protective hair covering to keep long hair out of the way.
- j) **Stay alert, watch what you are doing and use common sense when operating a power tool. Do not use a power tool while you are tired or under the influence of drugs, alcohol or medication.** A moment of inattention while operating power tools may result in serious personal injury.
- k) **Prevent unintentional starting. Ensure the switch is in the off-position before connecting to power source and/or battery pack, picking up or carrying the tool.** Carrying power tools with your finger on the switch or energizing power tools that have the switch on invites accidents.
- l) **Keep all parts of the body away from the cutting saw chain. Make sure the switch is off when clearing jammed material.** A moment of inattention while operating the appliance may result in serious personal injury.
- m) **Do not overreach and do not cut over shoulder height. Keep proper footing and balance at all times.** This enables better control of the power tool in unexpected situations.

### Electrical Safety

- n) **Power tool plugs must match the outlet. Never modify the plug in any way. Do not use any adapter plugs with earthed (grounded) power tools.** Unmodified plugs and matching outlets will reduce risk of electric shock.
- o) **Avoid body contact with earthed or grounded surfaces, such as pipes, radiators, ranges and refrigerators.** There is an increased risk of electric shock if your body is earthed or grounded.
- p) **Do not expose power tools to rain or wet conditions.** Water entering a power tool will increase the risk of electric shock.
- q) **Do not abuse the cord. Never use the cord for carrying, pulling or unplugging the power tool. Keep cord away from heat, oil, sharp edges or moving parts.** Damaged or entangled cords increase the risk of electric shock.
- r) **When operating a power tool outdoors, use an extension cord suitable for outdoor use.** Use of a cord suitable for outdoor use reduces the risk of electric shock.
- s) **If operating a power tool in a damp location is unavoidable, use a residual current device (RCD with a tripping current of 30mA or less) protected supply.** Use of an RCD reduces the risk of electric shock. NOTE! The term residual current device (RCD) may be replaced by the term "ground fault circuit interrupter (GFCI)" or "earth leakage circuit breaker (ELCB)".

## Safety Information

Important - Please read these instructions fully before operating or maintaining

### Operation Safety

- t) **Be certain the parts are fully tightened before operating the tool.** Check it periodically for tightness during use to avoid serious injury.
- u) **Risk of cut.** Do not touch or try to stop the cutting saw chain when they are moving.
- v) **Disconnect the plug.** Disconnect plug from the tool when not in use or when servicing or cleaning.
- w) **Check for damaged parts.** Before further use, carefully check the tool for damage. Check for alignment of moving parts, binding of moving parts, breakage of parts, mounting and any other condition that may affect its operation.  
Do not use the tool if any parts are damaged or defective. Have any damaged or defective parts repaired or replaced by an authorized service agent. Never attempt any repairs yourself.
- x) **Grip the tool securely.** Always hold the tool securely in both hands while working with it.
- y) **Keep handle dry, clean and free from oil and grease.** Slippery handles do not allow for safe handling and control of the tool in unexpected situations.
- z) **Keeps cable away from cutting area.** During operation the cable may be hidden in shrubs and can be accidentally cut by the saw chains.
- aa) **Do not overload the tool.** Only work in the performance range stated. Do not use tools that do not have sufficient power for heavy jobs. Do not use the tool for any use other than that intended by the manufacturer.
- bb) **Avoid damage to the tool.** Do not apply extra weight and do not drag the tool over hard surfaces such as tiles or steps.
- cc) **Do not operate a chainsaw while climbing in a tree.** Operation of a chainsaw while up in a tree may result in personal injury.
- dd) **Always keep proper footing and operate the chainsaw only when standing on fixed, secure and level surface.** Slippery or unstable surfaces such as ladders may cause a loss of balance or control of the chainsaw.
- ee) **When cutting a limb that is under tension, be alert for spring back.** When the tension in the wood fibers is released the spring loaded limb may strike the operator and/or throw the chainsaw out of control.
- ff) **Use extreme caution when cutting brush and saplings.** The slender material may catch the saw chain and be whipped toward you or pull you off balance.
- gg) **Follow instructions for lubricating, chain tensioning and changing accessories.** Improperly tensioned or lubricated chain may either break or increase the chance for kickback.
- hh) **Cut wood only.** Do not use chainsaw for purposes not intended. For example: do not use chainsaw for cutting plastic, masonry or non-wood building materials. Use of the chainsaw for operations different than intended could result in a hazardous situation.
- ii) **Maintain a firm grip with thumbs and fingers encircling the chainsaw handles, with both hands on the saw and position your body and arm to allow you to resist kickback forces.** Kickback forces can be controlled by the operator, if proper precautions are taken. Do not let go of the chainsaw.
- jj) **Kickback may occur when the nose or tip of the guide bar touches an object or when the wood closes in and pinches the saw chain in the cut.** Tip contact, in some cases, may cause a sudden reverse reaction, kicking the guide bar rapidly back to towards the operator. Either of these reactions may cause you to lose control of the saw which could result in serious personal injury. Do not rely exclusively upon the safety devices built into your saw. As a chainsaw user, you should take several steps to keep your cutting jobs free from accident or injury.
- kk) **Carry the chainsaw by the front handle with the chainsaw switched off and away from your body.** When transporting or storing the chainsaw, always fit the guide bar cover. Proper handling of the chainsaw will reduce the likelihood of accidental contact with the moving saw



## Safety Information

Important - Please read these instructions fully before operating or maintaining

### Operation Safety (continued)

chain.

ll) **Do not use the power tool if the switch does not turn it on and off.** Any power tool that cannot be controlled with the switch is dangerous and must be repaired.

mm) **Disconnect the plug from the power source before making any adjustments, changing accessories, or storing power tools.** Such preventive safety measures reduce the risk of starting the power tool accidentally.

nn) Cut the wood in right direction.

oo) The first-time user should, as a minimum practice cutting logs on a saw-horse or cradle.

pp) Before using the chainsaw, be sure to check the chain and bar in tension. Do not use the chainsaw if the chain and bar are loosen. Also confirm that no abnormal exists by actual test running.

### Maintenance and Storage

qq) **Maintain tools with care.** Keep tools clean and in good condition for better and safer performance. Follow the instructions for maintenance and changing accessories. Keep handles and switches dry, clean and free from oil and grease.

rr) **Be careful in handling the tool.** Keep the blades sharp and clean to improve its working safety and effectiveness. Follow the manufacturer's sharpening and maintenance instructions for the saw chain. Decreasing the depth gauge height can lead to increased kickback.

ss) **Store idle power tools out of the reach of children and do not allow persons unfamiliar with the power tool or these instructions to operate the power tool.** Power tools are dangerous in the hands of untrained users.

tt) **Only use replacement bars and chains specified by the manufacturer.** Use only suitable bar (Oregon 140SDEA074) and chain (Oregon 91PJ051X).

### Service

uu) **Have your tool repaired by an authorized service agent.** This tool is manufactured in accordance with the relevant safety regulations. To avoid danger, electrical appliances must only be repaired by qualified technicians.

## Preparing to Operate the Electric Chainsaw

### Step 1 - Switch on /off



**WARNING!** Always wear safety gloves when doing any work on the electric chainsaw.

**WARNING!** Always unplug the power cord from the power source before doing any work on the electric chainsaw.

The tool is completely assembled on delivery. Before you start up the electric chainsaw, adjust the chain, fill up with chain oil and check the automatic lubrication and chain break function.

1. Check before the start, whether sufficient chain oil is in the tank and, if necessary, refill with chain oil.
2. Release the chain brake, where you shift the chain brake trigger (10) back against the front grip (7).
3. Hold the electric chainsaw firmly with both hands, with the right hand on the rear grip and the left hand on the front handle. Thumb and finger must close securely over handles.
4. For switching on, activate the safety lock-off button (2) with the right thumb and then press the On/Off switch trigger (3), the electric power saw runs with highest speed. Release the safety lock-off button again.
5. The power saw switches off when you release the On/Off switch again. Switching for continuous running is not possible.

### Step 2 - Checking the oil automatic system



**NOTE!** Check the oil level and the oil automatic system before commencement of work.

1. Switch on the chainsaw and hold it above a bright background. The saw must not touch the ground.
2. If an oil trace can be seen, the chainsaw is working trouble-free. Select the oil regulator to prevent oil droplets forming, but also to prevent the chain from ever running dry. When the chainsaw is put away in storage, set the oil regulator to zero.
3. Clean the oil passages of the chain bar, in order to guarantee a trouble-free, automatic oiling of the saw chain during operation.

# Preparing to Operate the Electric Chainsaw

## Step 3 - Checking the chain brake

**NOTE!** The motor cannot be turned on if the chain brake has engaged. Do not employ the chain brake in order to start the chainsaw or to switch it off.

1. Release the chain brake by shifting the chain brake trigger (10) over against the front handle (7).
2. Place the electric chainsaw onto a solid, flat surface. It must not contact any objects.
3. Connect the tool to the mains voltage.
4. Hold the electric chainsaw firmly with both hands, with the right hand on the rear grip and the left hand on the front handle. Thumb and finger must close securely over the handles.
5. Turn on the electric chainsaw.
6. Activate chain brake trigger (10) with running motor by the left hand. Chain should stop abruptly.
7. Once the chain brake is working properly, release the on/off switch and the chain brake.

**WARNING!** If the chain brake does not function correctly, you must not use the electric chainsaw. A slack saw chain leads to danger of injury.

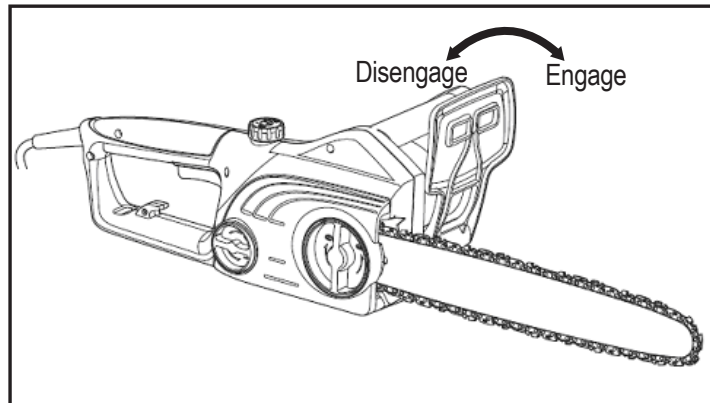

# Operating the Electric Chainsaw

**WARNING!** Always keep a firm grip on the tool with both hands and watch your feet. The saw chain must not contact either the ground or another object during sawing through or after sawing completion.

**WARNING!** Make sure that the saw chain does not become jammed in the wood. Do not let the tree trunk break or split off. If the saw chain jams, you do not attempt to pull out the electric chainsaw using power. There is a danger of injury here. Switch off the motor and use a lever or wedge to free the electric chainsaw.

**WARNING!** Consider also the precautions against spring-back.

## Overcutting

Overcutting begins on the top side of the log with the bottom of the saw against the log. When overcutting use light downward pressure.

## Undercutting

Undercutting involves cutting on the underside of the log with top of saw against the log. When undercutting use light upward pressure. Hold saw firmly and maintain control. The saw will tend to push back toward you.

**WARNING!** Never turn saw upside down to undercut. The saw cannot be controlled in this position.

## Cutting logs

### 1. Log is lying on the ground :

Saw through the log completely from above and ensure at the end of the cut not to contact the ground. See below figure.

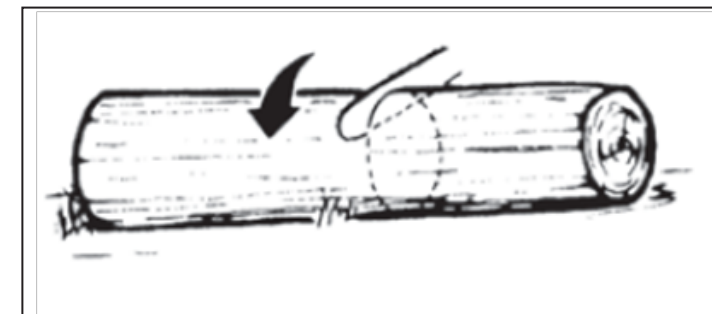

# Operating the Electric Chainsaw

## Cutting logs (continued)

### 2. Log is supported at one end :

Start sawing from the bottom and work your way up (with the upper edge of the bar) a third of the way into the diameter of the trunk to prevent splitting. Then saw from the top downwards with the lower edge of the bar towards the first cut to prevent the bar from becoming jammed in the wood. See below figure.

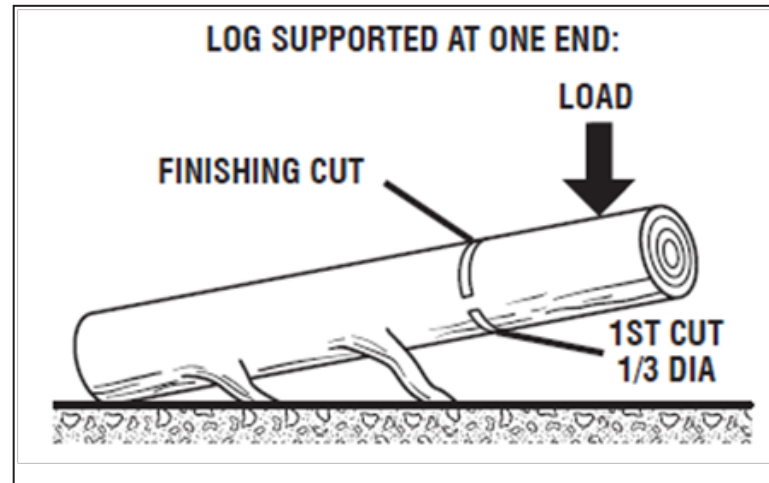

### 3. Log is supported at both ends :

First cut 1/3 of a diameter from the top. Next cut from below using the top of the bar, this will avoid pinching of the bar in wood. Avoid touching the ground with the bar.

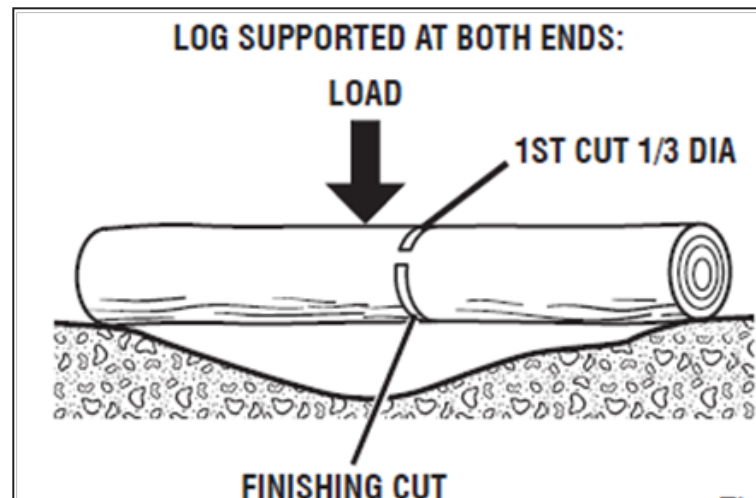

# Operating the Electric Chainsaw

## Cutting logs (continued)

### 4. Sawing on a support stand :

First cut 1/3 of a diameter from the blow, next cut from the top by using the bottom of the bar. See below figure.

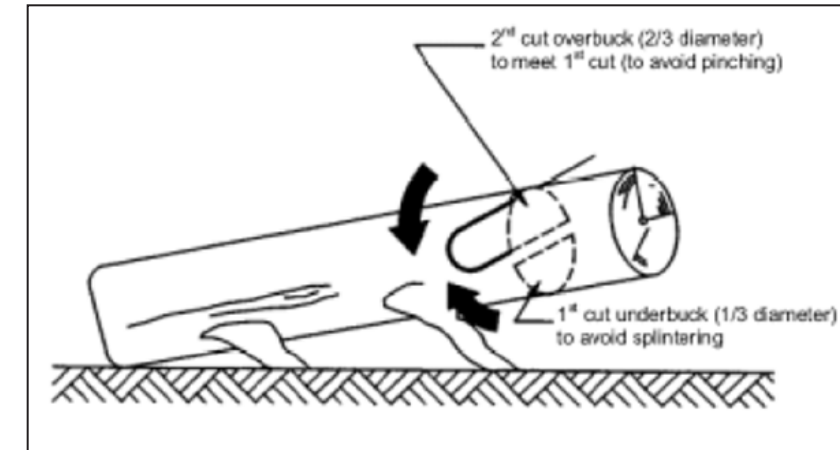

## Limbing

Limbing is removing branches from a fallen tree.

1. Work slowly, keeping both hands on the chainsaw with a firm grip. Always make sure your footing is secured and your weight is distributed evenly on both feet.
2. Leave the larger support limbs under the tree to keep the tree off the ground while cutting.
3. Limbs should be cut one at a time. Remove the cut limbs from the work area often to help keep the work area clean and safe.
4. Branches under tension should be cut from the bottom up to avoid binding the chain saw.
5. Keep the tree between you and the chainsaw while limbing. Cut from the side of the tree opposite the branch you are cutting.

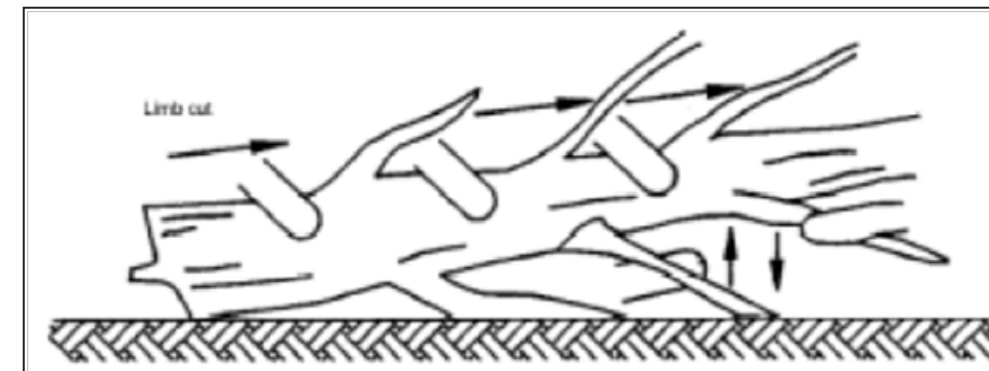

# Operating the Electric Chainsaw

## Pruning

Pruning is trimming limbs from a live tree.

1. Work slowly, keeping both hands on the chainsaw with a firm grip. Always make sure your footing is secure and your weight is distributed evenly on both feet.
2. Do not cut from a ladder, this is extremely dangerous. Leave this operation for professionals.
3. Do not cut above chest height as a saw held higher is difficult to control against kickback.
4. When pruning trees it is important not to make the finishing cut next to the main limb or trunk until you have cut off the limb further out to reduce the weight. This prevents stripping the bark from the main member.
5. Under buck the branch 1/3 through for your first cut.
6. Your second cut should over buck to drop the branch off.
7. Now make your finishing cut smoothly and neatly against the main member so the bark will grow back to seal the wound.

**WARNING!** If the limbs to be pruned are above chest height, hire a professional to perform the pruning.

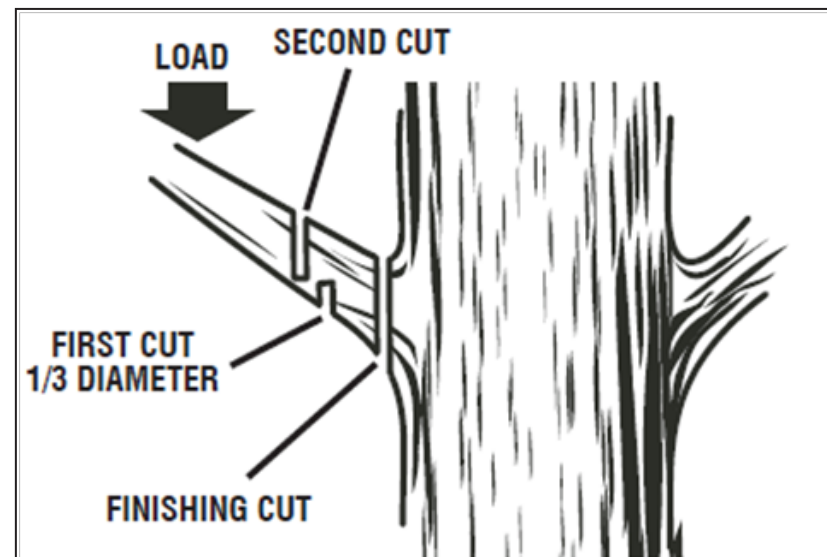

# Operating the Electric Chainsaw

## Felling trees

**WARNING!** If a tree starts to fall in the wrong direction, or if the saw gets caught or hung up during the fall, leave the saw and save yourself!

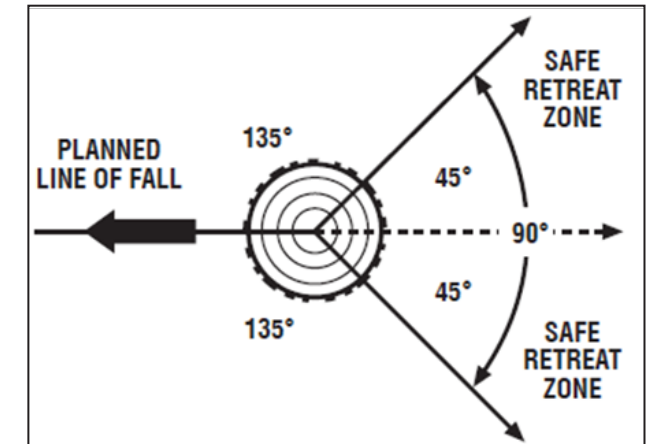
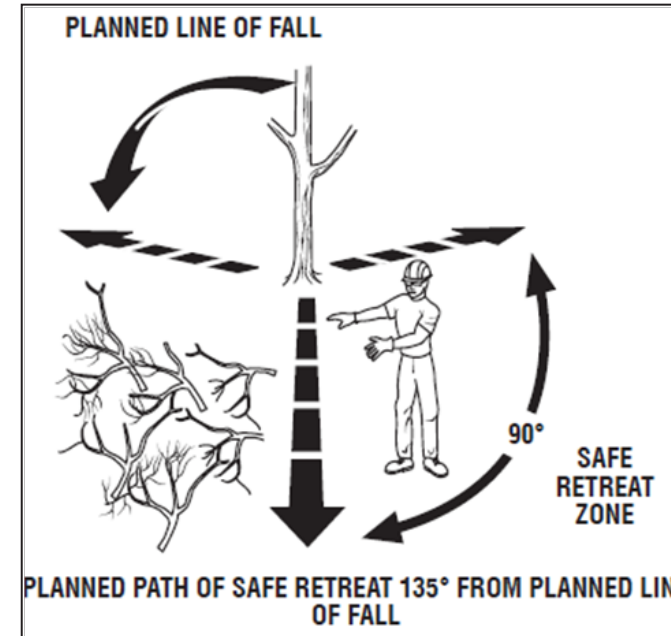

Felling a tree-when bucking and felling operations are being performed by two or more persons, at the same time, the felling operation should be separated from the bucking operation by a distance of at least twice the height of the tree being felled. Trees should not be felled in a manner that would endanger any person, strike any utility line or cause any property damage. If the tree does make contact with any utility line, the utility company should be notified immediately.

Before any cuts are started, pick your escape route (or routes in case the intended route is blocked); clear the immediate area around the tree and make sure there are no obstructions in your planned path of retreat. Clear path of safe retreat approximately 135° from planned line of fall. The retreat path should extend back and diagonally to the rear of the expected line of fall.

Before felling is started, consider the force and direction of the wind, the lean and balance of the tree, and the location of large limbs. These things influence the direction in which the tree will fall. Do not try to fell a tree along a line different from its natural line of fall.

The chainsaw operator should keep on the uphill side of the terrain as the tree is likely to roll or slide downhill after it is felled.

Remove dirt, stones, loose bark, nails, staples, and wire from the tree where felling cuts are to be made.



# Operating the Electric Chainsaw

## Felling trees (continued)

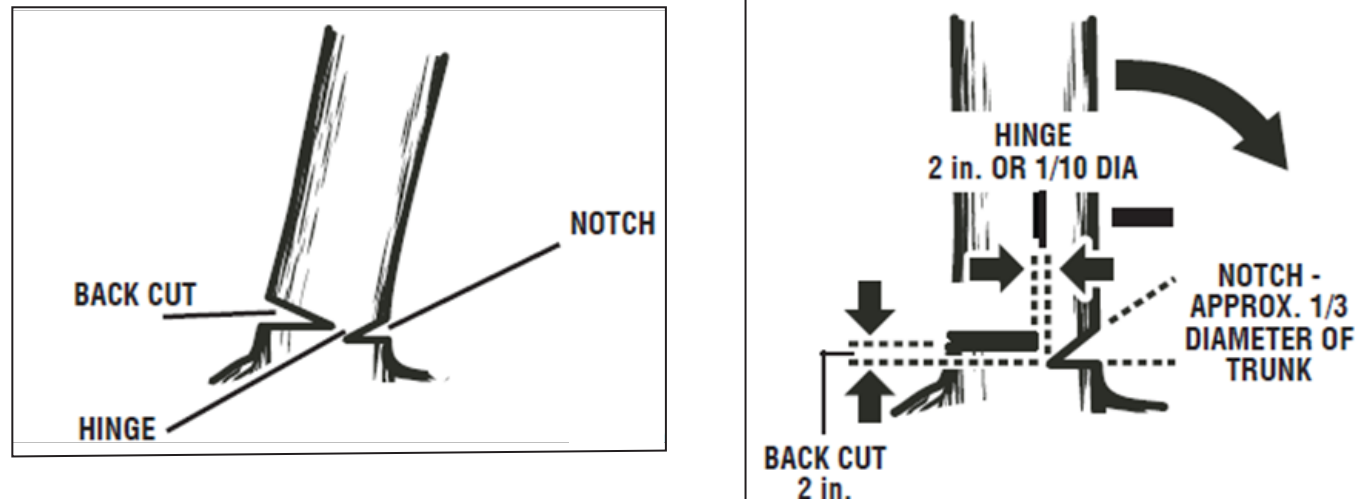

**Notched Undercut.** Cut a notch about 1/3 the diameter of the tree, perpendicular to the direction of fall. Make the cuts of the notch so they intersect at a right angle to the line of fall. This notch should be cleaned out to leave a straight line. To keep the weight of the wood off the saw, always make the lower cut of the notch before the upper cut.

**Felling backcut.** The back cut is always made level and horizontal, and at a minimum of 2 in. above the horizontal cut of the notch.

Never cut through to the notch. Always leave a band of wood between the notch and back cut (approximately 2 in. Or 1/10 the diameter of the tree). This is called “hinge” or “hinge wood”. It controls the fall of the tree and prevents slipping or twisting or shoot-back of the tree off the stump.

On large diameter trees, stop the back cut before it is deep enough for the tree to either fall or settle back on the stump. Then insert soft wooden or plastic wedges into the cut so they do not touch the chain. The wedges can be driven in, little by little, to help jack the tree over.



**NOTE!** When bucking or felling with a wedge, it may be necessary to remove the anti-kickback device to allow the bar to be drawn through the cut. After the cut is complete, the tip should be reinstalled immediately.

As tree starts to fall, stop the chain saw and put it down immediately. Retreat along the cleared path, but watch the action in case something falls your way. Be alert for overhead limbs or branches that may fall and watch your footing.



**WARNING!** Never cut through to the notch when making a backcut. The hinge controls the fall of the tree, this is the section of wood between the notch and backcut.

# Maintenance and Repair



**WARNING!** Always switch the product off and let the product cool down before performing inspection, maintenance and cleaning work!

**This chainsaw meets all current legislation requirements, in order to avoid injuries while repairing; every repair has to be carried out by a qualified member of staff in an authorized service centre.**

## General

- 1). Clean the product with a slightly damp cloth and pH-neutral soap. Use a brush for areas that are hard to reach.
- 2). In particular clean the air vents and chain guide on the bar after every use with a cloth and brush.
- 3). Remove stubborn dirt with high pressure air (max. 3 bar).
- 4). Check for worn or damaged parts. Replace worn parts as necessary or contact an authorised service centre for repair before using the product again.
- 5). Regularly check for obvious defects such as loose, dislodged or damaged cutting device, loose fixings and worn or damaged components.
- 6). Check that covers are undamaged and correctly fitted. Carry out necessary maintenance or repairs before using the product.
- 7) Regularly apply lubricant to the chain surface.
- 8) Ensure that the oil reservoir and the oil filter are clean.

## Chain sharpening

**WARNING!** Wear safety gloves when working on the chainsaw and close to it!

Periodically sharpen the blades as follows:

1. Disconnect the cord from the mains supply.
2. Wear protective gloves.
3. Ensure the chain is correctly tensioned and not too loose.
4. Engage the chain brake (10) to lock the chain on the bar (“Engage” position) when sharpening.
5. Use a round file for chain sharpening. Diameter equivalent to 1.1 times the cutting tooth depth.
6. File at a horizontal angle 35° to the bar.
7. File from inside towards outside of the tooth only.
8. Sharpen each tooth equally by using the same number of strokes.
9. File at an angle of 90° to the bar.
10. Check the safety depth gauge height in intervals while sharpening. Use depth gauge measuring instrument to check the height of the depth gauge.

# Maintenance and Repair

## Chain sharpening (continued)

### cleaning the guide bar lubricating the sprocket nose

---Regularly inspect the bearing surfaces of the guide bar for damage ,and clean them with a suitable tool.

If the saw is used intensively it will be necessary to lubricate the return sprocket bearings regularly(once a week).To do this ,first thoroughly clean the 2mm hole at the tip of the guide bar, and then press in a small amount of multi-purpose grease.

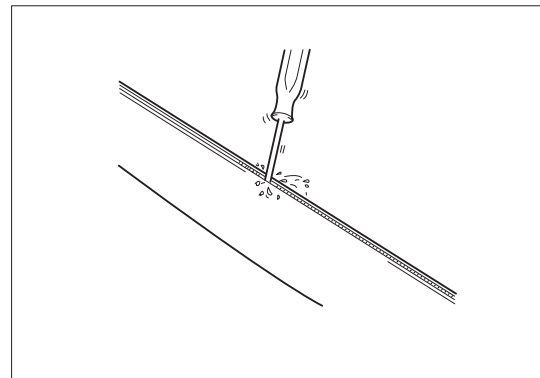
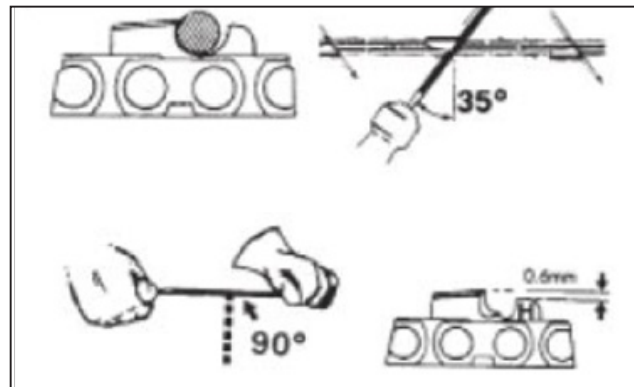

# Storage and Transportation

## Storage

- 1). Clean the product as described above.
- 2). Store the product and its accessories in a dark, dry, frost-free, well-ventilated place.
- 3). Always store the product in a place that is inaccessible to children. The ideal storage temperature is between 10 and 30°C.
- 4). We recommend using the original package for storage or covering the product with a suitable cloth or enclosure to protect it against dust.

## Transportation

- 1). Switch the product off and disconnect it from power supply before transporting it anywhere.
- 2). Always carry the product on its gripping surfaces.
- 3). Protect the product from any heavy impact or strong vibrations which may occur during transportation in vehicles.
- 4). Secure the product to prevent it from slipping or falling over.

# Troubleshooting

## General Troubleshooting



**CAUTION!** Only perform the steps described within these instructions!

All further inspection, maintenance and repair work must be performed by an authorized service centre or a similarly qualified specialist if you cannot solve the problem yourself!

Suspected malfunctions, disturbances or damages are often due to causes that the user can fix them. Therefore check the product using this section. In most cases the problem can be solved quickly.

Problem	Possible Cause	Solution
1. Product does not start	1. Not connected to power supply 2. Power connection is loosen 3. House protection fuse activated 4. Defective On/Off switch 5.Worn carbon brushes 6.Defective motor 7.Chain brake trigger saw chain	1. Connect to power supply 2.Connect the power supply and tool well 3. Check by a specialist electrician 4.Repair by customer service 5. Repair by customer service 6. Repair by customer service 7.Check chain brake trigger .Possibly release chain brake
2. Inferior cutting performance	1. Incorrectly mounted saw chain 2.saw chain blunt 3.Chain tension insufficient	1. Mount saw chain correctly 2. Sharpen cutting teeth or place on new chain 3. Check chain tension
3. Saw runs with difficulty ,chain comes off	Chain tension insufficient	Check chain tension
4. Chain becomes hot, smoke development during sawing, discoloration of the rail	Too little chain oil	1. Check oil level and where appropriate ,refill with chain oil, check oil automatic system and , where appropriate, clean oil outflow duct or have repaired by customer service 2. Contact Service Agent

# Technical Data

## Technical Data Table

Property	Value
Motor Voltage	230-240V ~/50Hz
Power Input	1800W
Electric motor no load speed	5600/min
Chain speed	13m/s
Insulation class	class II
Net weight	4.7Kg
Type of saw chain	Oregon 91PJ051X(14 ")
Type of guide bar	Oregon 140SDEA074(14 ")
Measured sound pressure level	94.5dB (A), k=3 dB (A)
Measured sound power level	109dB (A), k=3dB (A)
Guaranteed sound power level	110dB (A)
Vibration	6.5 m/s <sup>2</sup> , k=1.5 m/s <sup>2</sup>

The declared vibration value has been measured in accordance with a standard test method and may be used for comparing one tool with another. The declared vibration value may also be used in a preliminary assessment of exposure.



**WARNING!** The vibration emission value during actual use of the tool can differ from the declared value depending on the ways in which the tool is used. Identify safety measures to protect the operator that are based on an estimation of exposure in the actual conditions of use (taking account of all parts of the operating cycle such as the times when the tool is switched off and when it is running idle in addition to the trigger time).

The sound intensity level for the operator may exceed 85dB(A) and ear protection measures are necessary.

# Recycling and Disposal

## Recycling and Disposal

1. Recycle unwanted materials instead of disposing of them as waste. All tools, hoses and packaging should be sorted, taken to the local recycling centre and disposed of in an environmentally safe way.
2. Recycle rather than dispose of unwanted material in landfill whenever possible. The machine must be delivered in rigid packaging to avoid damage during transportation. The packaging and the machine itself are manufactured from recyclable materials and should be disposed of accordingly.
3. Do not throw your clippings into a rubbish bin where it will be disposed of in landfill. You can dispose of clippings on your compost heap, alternating then with other garden material. The more thoroughly you chop the clippings beforehand, the more rapidly they will degrade. Alternatively, many communities provide a public collection point where you can dispose of your garden waste in an environmentally friendly manner.
4. Only dispose of electrical/electronic/battery items in separate collection schemes, which cater for the recovery and recycling of materials contained within. Your cooperation is vital to ensure the

# Recycling and Disposal

## Recycling and Disposal (continued)

success of these schemes and for the protection of the environment.

5. Recycle packaging where facilities exist.



6. This symbol is known as the Crossed out Wheellie Bin Symbol. When this symbol is marked on a product or battery, it means that it should not be disposed of with your general household waste.

Some chemicals contained within electrical/electronic products or batteries can be harmful to health.

# Plug Replacement

## Plug Replacement

Your chain saw is fitted with a moulded plug. However if you need to replace a fitted plug then follow the instructions below.

### IMPORTANT

The wires in the mains lead are coloured in accordance with the following code:

Blue - Neutral Brown – Live

As the colours of the wires in the mains lead of this appliance may not correspond with the coloured markings identifying the terminals in your plug, proceed as follows.

The wire which is coloured blue must be connected to the terminal which is marked with N

The wire which is coloured brown must be connected to the terminal which is marked with the letter L

If a 13AMP (BS1363/A) plug is used, a 13A fuse must be fitted, or if any other type of plug is used a 13AMP fuse must be fitted, either in the plug or adapter, or on the distribution board.

Note: If a moulded plug is fitted and has to be removed take great care in disposing of the plug and severed cable, it must be destroyed to prevent engaging into a socket. If the supply cord is damaged it must be replaced by a service agent or a similarly qualified person in order to avoid hazard.

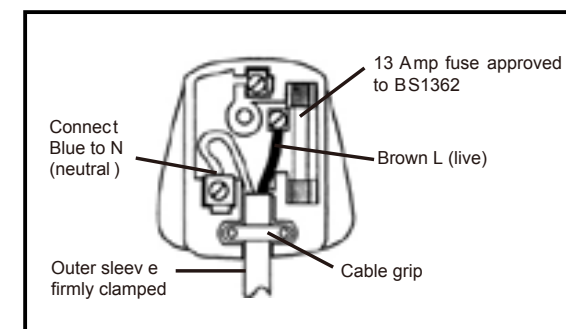

# Guarantee

Dear Customer,

In the unlikely event that your device develops a fault, please contact our Customer service department on the telephone number shown below.

1. These guarantee terms cover additional guarantee rights and do not affect your statutory warranty rights. Claims must be accompanied by Proof of Purchase. This must be in the form of a Sales receipt or Bank statement and must show that the product has been purchased within 1 year prior to the claim, from the retailer that it was originally sold to.

2. Our guarantee covers problems caused by material or manufacturing defects, and will result in the repair of these defects or replacement of the device with a like for like or similar article. Please note that our devices have not been designed for use in commercial, trade or industrial applications. Consequently, the guarantee is invalidated if the equipment is used in commercial, trade or industrial applications or for other equivalent activities.

3. The following are also excluded from our guarantee:

- A. Faults due to accidents, customer misuse, or unauthorized repairs
- B. Consumable Parts such as bar and chain
- C. Failure due to lack of routine maintenance
- D. Failure as a result of not using the equipment in accordance with the manual and safety instructions

4. The guarantee is valid for a period of 1 years starting from the purchase date of the device. Guarantee claims should be submitted before the end of the guarantee period within two weeks of the defect being noticed. No guarantee claims will be accepted after the end of the guarantee period. The original guarantee period remains applicable to the device even if repairs are carried out or parts are replaced. In such cases, the work performed or parts fitted will not result in an extension of the guarantee period, and no new guarantee will become active for the work performed or parts fitted. This also applies when an on-site Service is used.

5. Please keep your sales receipt in a safe place .If the defect is covered by our guarantee your device will either be repaired under the terms of guarantee or we will send you a replacement device. This device may be re-conditioned or Like for like replacement.